

Pictorial index	Search by illustration	
For safety and security	Make sure to read through them (Main topics: Child seat, theft deterrent system)	1
Vehicle status information and indicators	Reading driving-related information (Main topics: Meters, multi-information display)	2
Before driving	Opening and closing the doors and windows, adjustment before driving (Main topics: Keys, doors, seats, power windows)	3
Driving	Operations and advice which are necessary for driving (Main topics: Starting engine, refueling)	4
Interior features	Usage of the interior features (Main topics: Air conditioner, storage features)	5
Maintenance and care	Caring for your vehicle and maintenance procedures (Main topics: Interior and exterior, light bulbs)	6
When trouble arises	What to do in case of malfunction and emergency (Main topics: Battery discharge, flat tire)	7
Vehicle specifications	Vehicle specifications, customizable features (Main topics: Fuel, oil, tire inflation pressure)	8
Index	Search by symptom	
	Search alphabetically	

2 TABLE OF CONTENTS

For your information	6
Reading this manual	9
How to search	10
Pictorial index	12

1 For safety and security

1-1. For safe use	
Before driving	32
For safe driving	33
Seat belts	34
SRS airbags	38
Exhaust gas precautions	45
1-2. Child safety	
Airbag manual on-off system	47
Riding with children	48
Child restraint systems	49
1-3. Emergency assistance	
eCall	64
ERA-GLONASS/EVAK	80
1-4. Theft deterrent system	
Engine immobilizer system	84
Double locking system	96
Alarm	97

2 Vehicle status information and indicators

2-1. Instrument cluster	
Warning lights and indicators ..	104
Gauges and meters (except F SPORT models)	108
Gauges and meters (F SPORT models)	111
Multi-information display	115
Head-up display	122
Fuel consumption information ..	126

3 Before driving

3-1. Key information	
Keys	130
3-2. Opening, closing and locking the doors	
Side doors	134
Back door	138
Smart entry & start system	151
3-3. Adjusting the seats	
Front seats	184
Rear seats	185
Driving position memory	187
Head restraints	190
3-4. Adjusting the steering wheel and mirrors	
Steering wheel	192
Inside rear view mirror	193
Outside rear view mirrors	195
3-5. Opening, closing the windows and moon roof	
Power windows	197
Moon roof	199

4 Driving

4-1. Before driving	
Driving the vehicle	204
Cargo and luggage	209
Trailer towing (vehicles without towing package)	211
Trailer towing (vehicles with towing package)	211

4-2. Driving procedures	PKSB (Parking Support Brake) 324	
Engine (ignition) switch 217	Parking Support Brake function (static objects)..... 328	
Multidrive 220	Parking Support Brake function (rear-crossing vehicles)..... 333	
Turn signal lever 224	Driving mode select switch 337	1
Parking brake 225	Exhaust Gas Filter system..... 339	
Brake Hold..... 228	Driving assist systems 339	
ASC (Active Sound Con- trol/Acceleration Sound Control) 230	4-6. Driving tips	2
4-3. Operating the lights and wipers	Winter driving tips 344	
Headlight switch..... 231	Utility vehicle precautions..... 347	
AHS (Adaptive High-beam Sys- tem)..... 233		3
Automatic High Beam 237	5 Interior features	
Fog light switch 239		4
Windshield wipers and washer 241	5-1. Remote Touch	
Rear window wiper and washer 245	Remote Touch..... 350	
4-4. Refueling	5-2. Lexus Climate Concierge	5
Opening the fuel tank cap..... 247	Lexus Climate Concierge 354	
4-5. Using the driving support systems	5-3. Using the air conditioning system and defogger	6
Lexus Safety System+ 249	Automatic air conditioning system 356	7
PCS (Pre-Collision System).... 260	Heated steering wheel/seat heat- ers/seat ventilators 365	
LTA (Lane Tracing Assist)..... 268	5-4. Using the interior lights	8
RSA (Road Sign Assist)..... 277	Interior lights list 369	
Dynamic radar cruise control with full-speed range..... 281	5-5. Using the storage features	
Cruise control 292	List of storage features 372	
Stop & Start system..... 294	Luggage compartment features 375	
BSM (Blind Spot Monitor) 301	5-6. Using the other interior features	
PKSA (Parking Support Alert) 312	Other interior features 380	
Lexus parking assist-sensor..... 313		
RCTA (Rear Crossing Traffic Alert) function..... 320		

6 Maintenance and care

6-1. Maintenance and care

- Cleaning and protecting the vehicle exterior **390**
- Cleaning and protecting the vehicle interior **393**

6-2. Maintenance

- Maintenance requirements **396**

6-3. Do-it-yourself maintenance

- Do-it-yourself service precautions **398**
- Hood **400**
- Positioning a floor jack **401**
- Engine compartment **402**
- Tires **409**
- Tire inflation pressure **424**
- Wheels **425**
- Air conditioning filter **426**
- Electronic key battery **428**
- Checking and replacing fuses **430**
- Light bulbs **432**

7 When trouble arises

7-1. Essential information

- Emergency flashers **436**
- If your vehicle has to be stopped in an emergency **436**
- If the vehicle is trapped in rising water **437**

7-2. Steps to take in an emergency

- If your vehicle needs to be towed **439**
- If you think something is wrong **442**

Fuel pump shut off system **443**

If a warning light turns on or a warning buzzer sounds **444**

If a warning message is displayed **452**

If you have a flat tire (vehicles with emergency tire puncture repair kit) **455**

If you have a flat tire (vehicles with spare tire) **467**

If you have a flat tire (vehicles with run-flat tires) **476**

If the engine will not start **477**

If you lose your keys **479**

If the fuel filler door cannot be opened **479**

If the electronic key does not operate properly **480**

If the vehicle battery is discharged **482**

If your vehicle overheats **485**

If the vehicle becomes stuck ... **487**

8 Vehicle specifications

8-1. Specifications

- Maintenance data (fuel, oil level, etc.) **490**
- Fuel information **499**

8-2. Customization

- Customizable features **501**

8-3. Initialization

- Items to initialize **515**

Index

What to do if... (Troubleshooting)
..... 518
Alphabetical Index 521



For your information

WARNING

■ General precautions while driving

Driving under the influence: Never drive your vehicle when under the influence of alcohol or drugs that have impaired your ability to operate your vehicle. Alcohol and certain drugs delay reaction time, impair judgment and reduce coordination, which could lead to an accident that could result in death or serious injury.

Defensive driving: Always drive defensively. Anticipate mistakes that other drivers or pedestrians might make and be ready to avoid accidents.

Driver distraction: Always give your full attention to driving. Anything that distracts the driver, such as adjusting controls, talking on a cellular phone or reading can result in a collision with resulting death or serious injury to you, your occupants or others.

■ General precaution regarding children's safety

Never leave children unattended in the vehicle, and never allow children to have or use the key.

Children may be able to start the vehicle or shift the vehicle into neutral. There is also a danger that children may injure themselves by playing with the windows, the moon roof, or other features of the vehicle. In addition, heat build-up or extremely cold temperatures inside the vehicle can be fatal to children.

Main Owner's Manual

Please note that this manual applies to all models and explains all equipment, including options. Therefore, you may find some explanations for equipment not installed on your vehicle.

All specifications provided in this manual are current at the time of printing. However, because of the Lexus policy of continual product improvement, we reserve the right to make changes at any time without notice.

Depending on specifications, the vehicle shown in the illustrations may differ from your vehicle in terms of color and equipment.

Accessories, spare parts and modification of your Lexus

Both genuine Lexus and a wide variety of other spare parts and accessories for Lexus vehicles are currently available in the market. Should it be determined that any of the genuine Lexus parts or accessories supplied with the vehicle need to be replaced, Lexus recommends that genuine Lexus parts or accessories, be used to replace them. Other parts or accessories of matching quality can also be used.

Lexus cannot accept any liability or guarantee spare parts and accessories which are not genuine Lexus products, nor for replacement or installation involving such parts. In addition, damage or performance problems resulting from the use of non-genuine Lexus spare parts or accessories may not be covered under warranty.

Installation of an RF-transmitter system

The installation of an RF-transmitter system in your vehicle could affect electronic systems such as:

- Multipoint fuel injection system/sequential multipoint fuel injection system
- Lexus Safety System+
- Cruise control system
- Anti-lock brake system
- SRS airbag system
- Seat belt pretensioner system

Be sure to check with any authorized Lexus retailer or Lexus authorized repairer, or any reliable repairer for precautionary measures or special instructions regarding installation of an RF-transmitter system.

Further information regarding frequency bands, power levels, antenna positions and installation provisions for the installation of RF-transmitters, is available on request at any authorized Lexus retailer or Lexus authorized repairer, or any reliable repairer.

Vehicle data recording

The vehicle is equipped with sophisticated computers that will record certain data, such as:

The recorded data varies according to the vehicle grade level and options with which it is equipped.

These computers do not record conversations or sounds, and only record images outside of the vehicle in certain situations.

- Engine speed / Electric motor speed (traction motor speed)
- Accelerator status
- Brake status
- Vehicle speed
- Vehicles with PCS (Pre-Collision System): Operation status of the driving assist systems, such as the ABS and pre-collision system
- Vehicles without PCS (Pre-Collision System): Operation status of the driving assist systems, such as the ABS and VSC
- Data usage

Lexus may use the data recorded in this computer to diagnose malfunctions, conduct research and development, and improve quality.

Lexus will not disclose the recorded data to a third party except:

- With the consent of the vehicle owner or with the consent of the lessee if the vehicle is leased
- In response to an official request by the police, a court of law or a government agency
- For use by Lexus in a lawsuit
- For research purposes where the data is not tied to a specific vehicle or vehicle owner



Scrapping of your Lexus

The SRS airbag and seat belt pretensioner devices in your Lexus contain explosive chemicals. If the vehicle is scrapped with the airbags and seat belt pretensioners left as they are, this may cause an accident such as fire. Be sure to have the systems of the SRS airbag and seat belt pretensioner removed and disposed of by any authorized Lexus retailer or Lexus authorized repairer, or any reliable repairer before you scrap your vehicle.

Reading this manual



Explains symbols used in this manual

Symbols in this manual

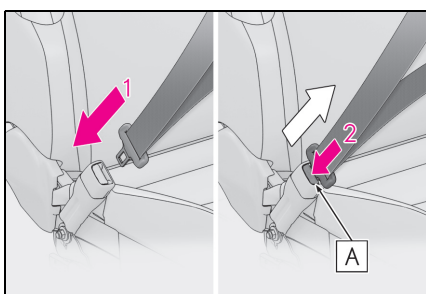

Symbols	Meanings
	WARNING: Explains something that, if not obeyed, could cause death or serious injury to people.
	NOTICE: Explains something that, if not obeyed, could cause damage to or a malfunction in the vehicle or its equipment.
	Indicates operating or working procedures. Follow the steps in numerical order.

Symbols in illustrations

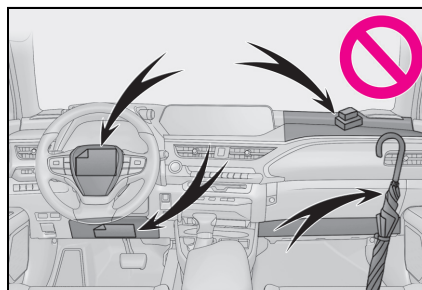

Symbols	Meanings
	Indicates the action (pushing, turning, etc.) used to operate switches and other devices.
	Indicates the outcome of an operation (e.g. a lid opens).



Symbols	Meanings
	Indicates the component or position being explained.
	Means Do not , Do not do this , or Do not let this happen .

How to search

■ Searching by name

- Alphabetical index: →P.521

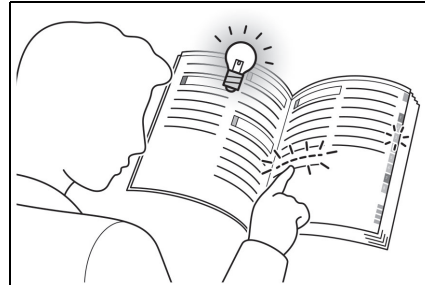
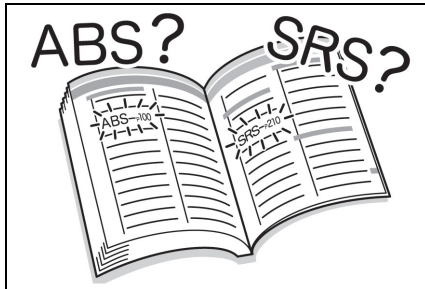

■ Searching by installation position

- Pictorial index: →P.12

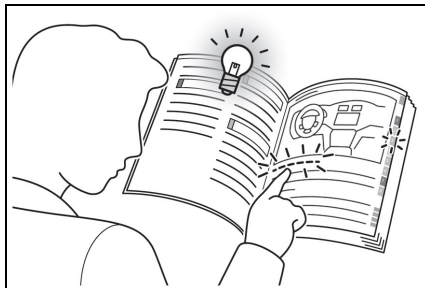

■ Searching by symptom or sound

- What to do if... (Troubleshooting):
→P.518

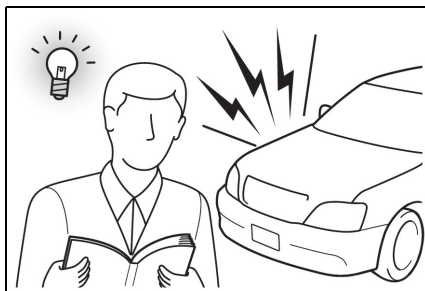

■ Searching by title

- Table of contents: →P.2

Pictorial index

■ Exterior

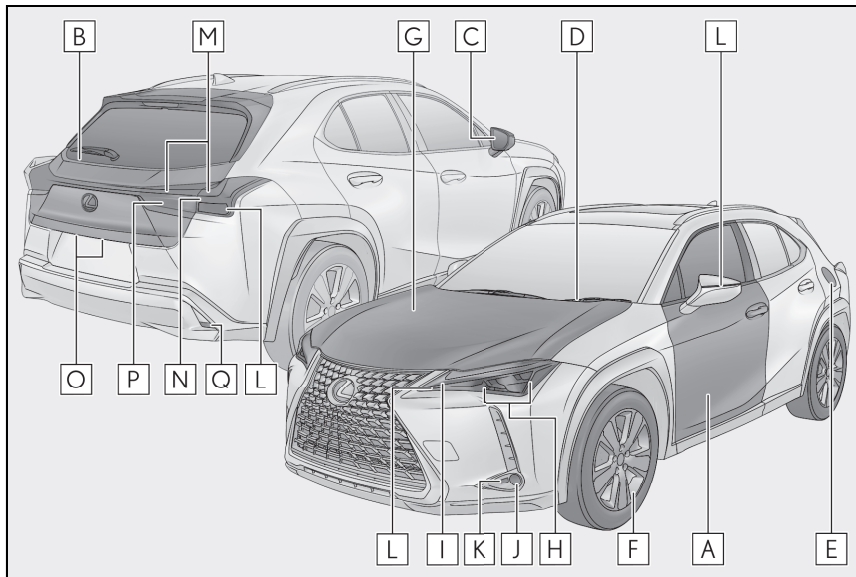

The shape of the headlights may differ depending on the grade, etc.

A	Side doors	P.134
	Locking/unlocking.....	P.134
	Opening/closing the side windows.....	P.197
	Locking/unlocking by using the mechanical key.....	P.480
	Warning messages.....	P.452
B	Back door	P.138
	Locking/unlocking.....	P.140
	Opening/closing the back door.....	P.140
	Power back door [*]	P.141
	Warning messages.....	P.452
C	Outside rear view mirrors	P.195
	Adjusting the mirror angle.....	P.195
	Folding the mirrors.....	P.196
	Driving position memory [*]	P.187

	Defogging the mirrors.....	P.357
D	Windshield wipers	P.241
	Precautions against winter season.....	P.344
	To prevent freezing (windshield wiper de-icer)*	P.361
	Precautions against car wash (Rain-sensing windshield wipers)*	P.391
E	Fuel filler door	P.247
	Refueling method	P.247
	Fuel type/fuel tank capacity	P.492
F	Tires	P.409
	Tire size/inflation pressure.....	P.496
	Winter tires/tire chain	P.344
	Checking/rotation/tire pressure warning system	P.409
	Coping with flat tires	P.455, 467, 476
G	Hood	P.400
	Opening	P.400
	Engine oil.....	P.493
	Coping with overheat.....	P.485
	Warning messages	P.452

Light bulbs of the exterior lights for driving
(Replacing method: P.432, Watts: P.498)

H	Headlights	P.231
I	Front position lights/daytime running lights	P.231
J	Front fog lights *	P.239
K	Cornering lights *	P.233
L	Turn signal lights	P.224
M	Tail lights	P.231
N	Stop lights	
	Emergency brake signal.....	P.340

O	License plate lights	P.231
P	Rear fog lights	P.239
Q	Back-up light	
	Shifting the shift lever to R.....	P.221

* : If equipped

■ Instrument panel (left-hand drive vehicles)

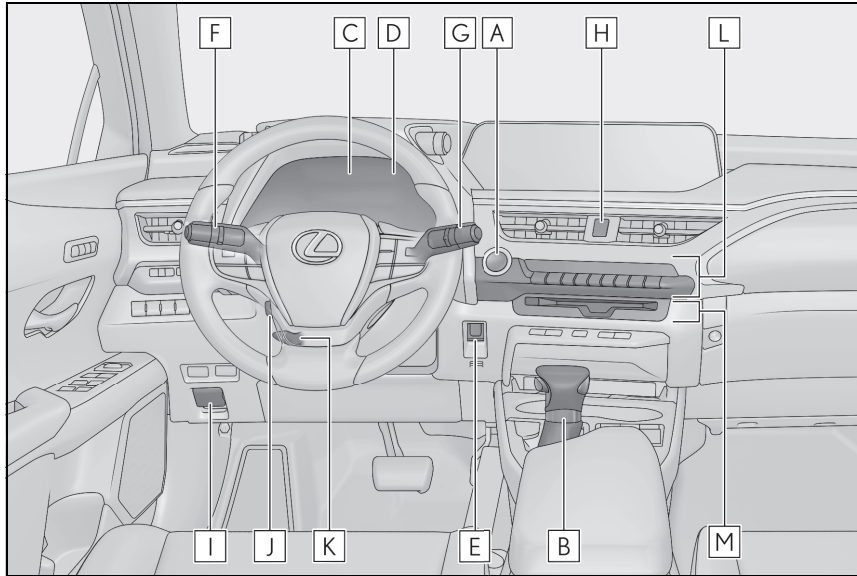

- A Engine switch**..... P.217
 - Starting the engine/changing the modes..... P.217
 - Emergency stop of the engine P.436
 - When the engine will not start P.477
 - Warning messages P.452
- B Shift lever**..... P.220
 - Changing the shift position..... P.221
 - Precautions against towing P.439
 - When the shift lever does not move P.222
- C Meters** P.108, 111
 - Reading the meters/adjusting the instrument panel light P.108,110, 111, 114
 - Warning lights/indicator lights P.104
 - When the warning lights come on P.444
- D Multi-information display** P.115
 - Display..... P.115

	When the warning messages are displayed	P.452
E	Parking brake switch	P.225
	Applying/releasing	P.225
	Precautions against winter season.....	P.345
	Warning buzzer/ message	P.446, 452
F	Turn signal lever	P.224
	Headlight switch	P.231
	Headlights/front position lights/tail lights/license plate lights/ daytime running lights	P.231
	AHS (Adaptive High-beam System) ^{*1}	P.233
	Automatic High Beam ^{*1}	P.237
	Front fog lights ^{*1} /rear fog lights	P.239
G	Windshield wiper and washer switch	P.241
	Rear window wiper and washer switch	P.245
	Usage	P.241, 245
	Adding washer fluid.....	P.408
	Headlight cleaners ^{*1}	P.241
	Warning messages	P.452
H	Emergency flasher switch	P.436
I	Hood lock release lever	P.400
J	Tilt and telescopic steering control switch ^{*1}	P.192
	Adjustment.....	P.192
	Driving position memory ^{*1}	P.187
K	Tilt and telescopic steering lock release lever ^{*1}	P.192
	Adjustment.....	P.192
L	Air conditioning system	P.356
	Usage	P.356
	Rear window defogger	P.357
M	Audio system ^{*2}	

*1: If equipped

*2: Refer to "NAVIGATION AND MULTIMEDIA SYSTEM OWNER'S MANUAL".

■ Switches (left-hand drive vehicles)

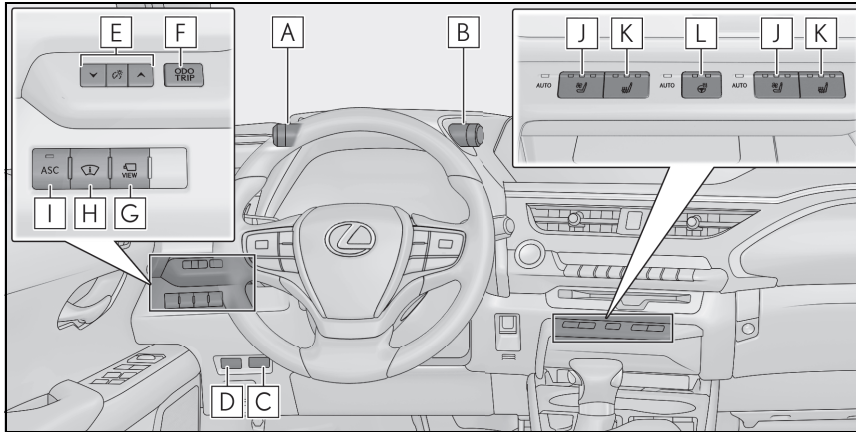

A	VSC off switch.....	P.341
B	Driving mode select switch	P.337
C	Power back door switch ^{*1}	P.142
D	Fuel filler door opener switch.....	P.248
E	Instrument panel light control switches	P.110, 114
F	Odometer/trip meter and trip meter reset button	P.109, 114
G	Camera switch ^{*1,2}	
H	Head-up display switch ^{*1}	P.122
I	ASC switch ^{*1}	P.230
J	Seat ventilator switches ^{*1}	P.366
K	Seat heater switches ^{*1}	P.366
L	Heated steering wheel switch ^{*1}	P.366

^{*1}: If equipped

^{*2}: Refer to "NAVIGATION AND MULTIMEDIA SYSTEM OWNER'S MANUAL".

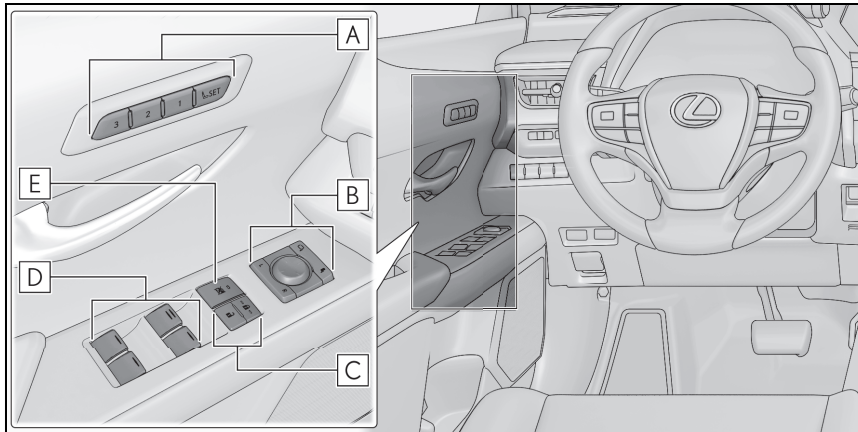

- A** Driving position memory switches *P.187
- B** Outside rear view mirror switchesP.195
- C** Door lock switchesP.136
- D** Power window switchesP.197
- E** Window lock switch.....P.199

*: If equipped

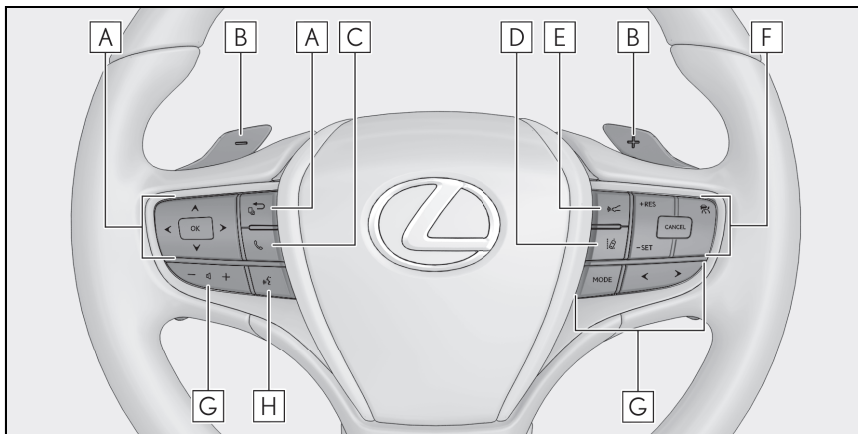

- A** Meter control switches P.117
- B** Paddle shift switches ^{*1}P.222, 223

- C** TEL switch^{*2}
- D** LTA (Lane Tracing Assist) switch^{*1} P.273
- E** Vehicle-to-vehicle distance switch^{*1} P.286
- F** Cruise control switches
 - Cruise control^{*1} P.292
 - Dynamic radar cruise control with full-speed range^{*1}P.281
- G** Audio remote control switches^{*2}
- H** Talk switch^{*2}

^{*1}: If equipped

^{*2}: Refer to "NAVIGATION AND MULTIMEDIA SYSTEM OWNER'S MANUAL".

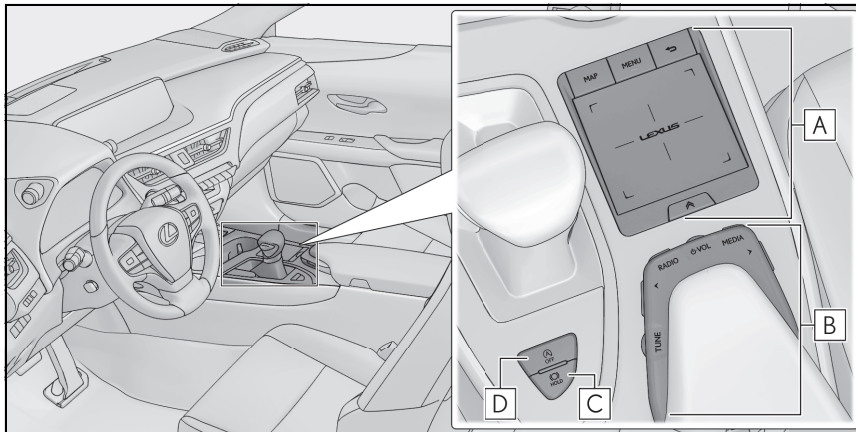

- A** Remote Touch..... P.350
- B** Audio control switches^{*}
- C** Brake hold switch P.228
- D** Stop & Start cancel switch..... P.299

^{*}: Refer to "NAVIGATION AND MULTIMEDIA SYSTEM OWNER'S MANUAL".

■ Interior (left-hand drive vehicles)

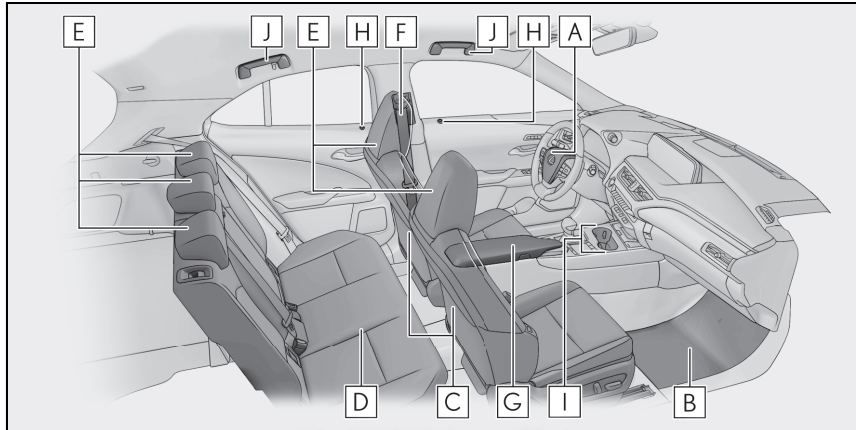

A SRS airbags	P.38
B Floor mats	P.32
C Front seats	P.184
D Rear seats	P.185
E Head restraints	P.190
F Seat belts	P.34
G Console box	P.373
H Inside lock buttons	P.136
I Cup holders	P.373
J Assist grips	P.387

■ Ceiling (left-hand drive vehicles)

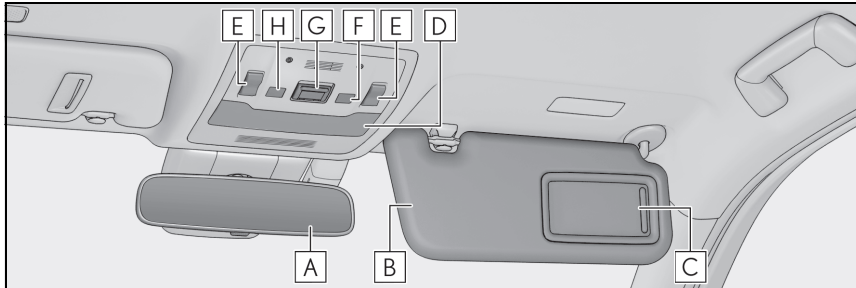

- A** Inside rear view mirrorP.193
- B** Sun visors ^{*1} P.380
- C** Vanity mirrors P.380
- D** Interior light ^{*2} P.370
Personal lights P.371
- E** Moon roof switches ^{*3}P.199
- F** Door-linked interior light switch P.370
- G** "SOS" button ^{*3}P.64, 80
- H** Intrusion sensor cancel switch ^{*3} P.99
Intrusion sensor and tilt sensor cancel switch ^{*3} P.99

^{*1}: NEVER use a rearward facing child restraint on a seat protected by an ACTIVE AIR-BAG in front of it, DEATH or SERIOUS INJURY to the CHILD can occur. (→P.51)



^{*2}: The illustration shows the front, but they are also equipped in the rear.

^{*3}: If equipped

■ Instrument panel (right-hand drive vehicles)

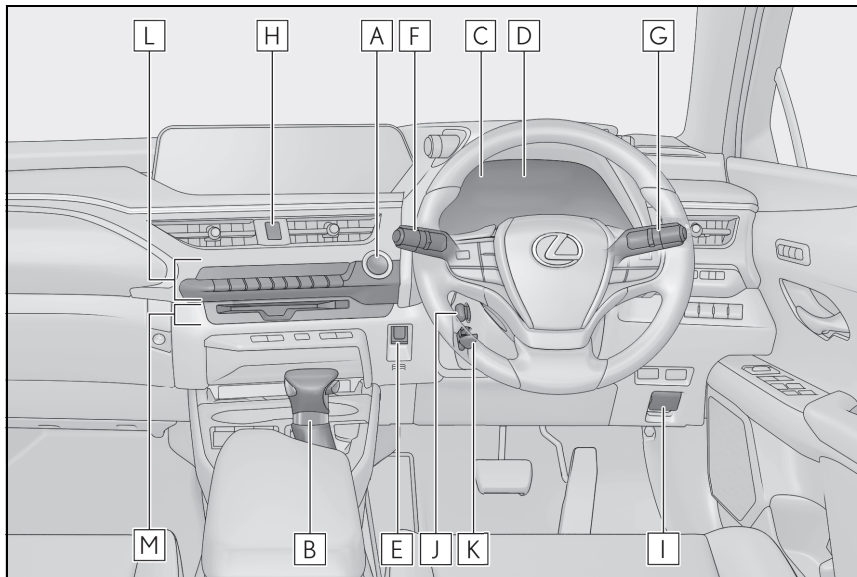

- A Engine switch**..... P.217
 - Starting the engine/changing the modes..... P.217
 - Emergency stop of the engine P.436
 - When the engine will not start P.477
 - Warning messages P.452
- B Shift lever**..... P.220
 - Changing the shift position..... P.221
 - Precautions against towing P.439
 - When the shift lever does not move P.222
- C Meters** P.108, 111
 - Reading the meters/adjusting the instrument panel light P.108,110, 111, 114
 - Warning lights/indicator lights P.104
 - When the warning lights come on P.444
- D Multi-information display** P.115
 - Display..... P.115

	When the warning messages are displayed	P.452
E	Parking brake switch	P.225
	Applying/releasing	P.225
	Precautions against winter season.....	P.345
	Warning buzzer/ message	P.446, 452
F	Turn signal lever	P.224
	Headlight switch	P.231
	Headlights/front position lights/tail lights/license plate lights/ daytime running lights	P.231
	AHS (Adaptive High-beam System) *1	P.233
	Automatic High Beam *1	P.237
	Front fog lights *1/rear fog lights	P.239
G	Windshield wiper and washer switch	P.241
	Rear window wiper and washer switch	P.245
	Usage	P.241, 245
	Adding washer fluid.....	P.408
	Headlight cleaners *1	P.241
	Warning messages	P.452
H	Emergency flasher switch	P.436
I	Hood lock release lever	P.400
J	Tilt and telescopic steering control switch *1	P.192
	Adjustment.....	P.192
	Driving position memory *1	P.187
K	Tilt and telescopic steering lock release lever *1	P.192
	Adjustment.....	P.192
L	Air conditioning system	P.356
	Usage	P.356
	Rear window defogger	P.357
M	Audio system *2	

*1: If equipped

*2: Refer to "NAVIGATION AND MULTIMEDIA SYSTEM OWNER'S MANUAL".

■ Switches (right-hand drive vehicles)

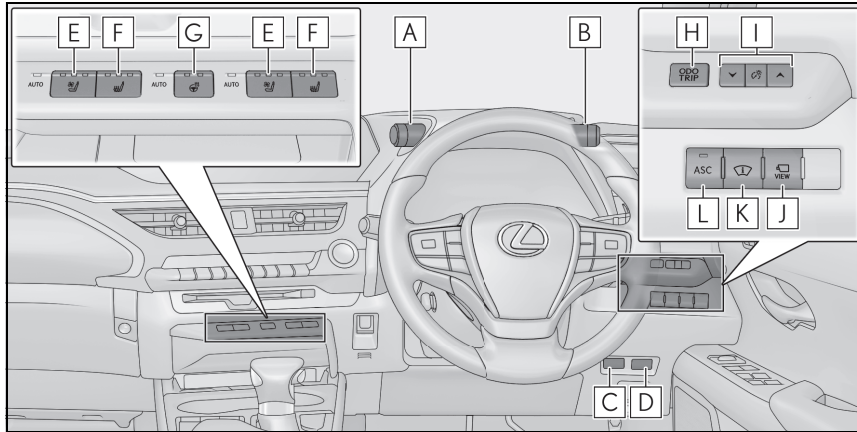

- A** Driving mode select switch P.337
- B** VSC off switch P.341
- C** Fuel filler door opener switch P.248
- D** Power back door switch^{*1} P.142
- E** Seat ventilator switches^{*1} P.366
- F** Seat heater switches^{*1} P.366
- G** Heated steering wheel switch^{*1} P.366
- H** Odometer/trip meter and trip meter reset button P.109, 114
- I** Instrument panel light control switches P.110, 114
- J** Camera switch^{*1,2}
- K** Head-up display switch^{*1} P.122
- L** ASC switch^{*1} P.230

^{*1}: If equipped

^{*2}: Refer to "NAVIGATION AND MULTIMEDIA SYSTEM OWNER'S MANUAL".

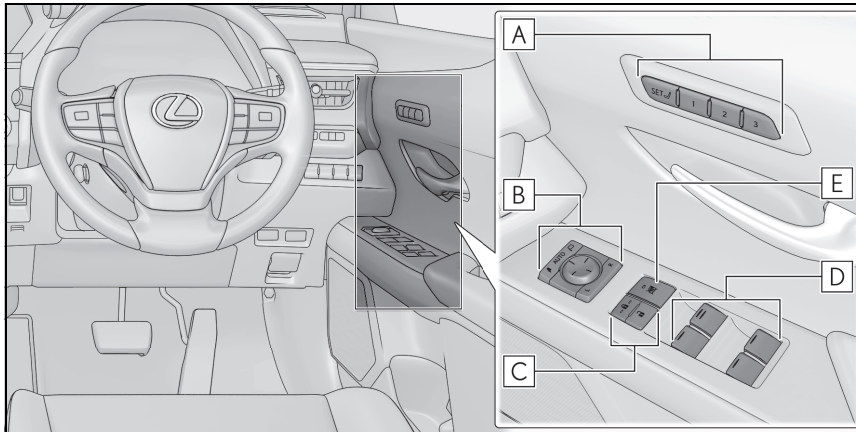

- A** Driving position memory switches *P.187
- B** Outside rear view mirror switchesP.195
- C** Door lock switchesP.136
- D** Power window switchesP.197
- E** Window lock switch.....P.199

*: If equipped

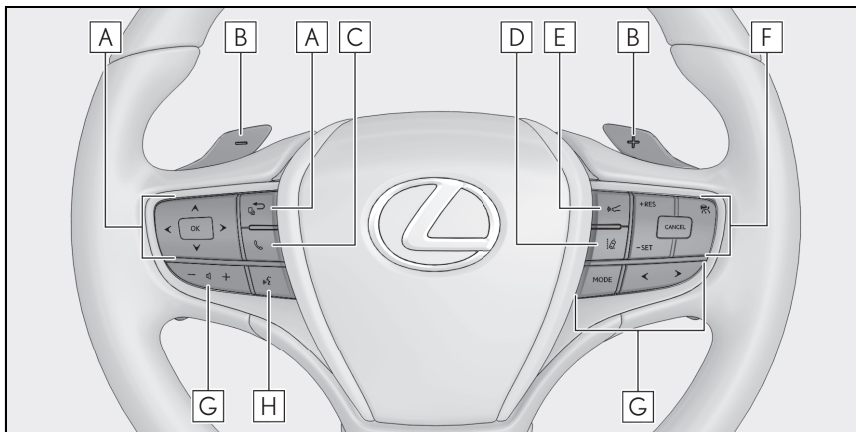

- A** Meter control switches P.117
- B** Paddle shift switches ^{*1}P.222, 223

- C** TEL switch^{*2}
- D** LTA (Lane Tracing Assist) switch P.273
- E** Vehicle-to-vehicle distance switch P.286
- F** Cruise control switches P.281
- G** Audio remote control switches^{*2}
- H** Talk switch^{*2}

^{*1}: If equipped

^{*2}: Refer to "NAVIGATION AND MULTIMEDIA SYSTEM OWNER'S MANUAL".

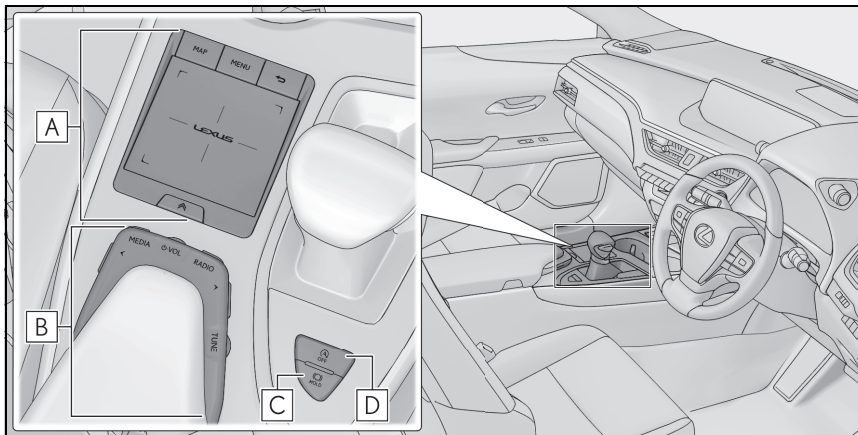

- A** Remote Touch..... P.350
- B** Audio control switches^{*}
- C** Brake hold switch P.228
- D** Stop & Start cancel switch..... P.299

^{*}: Refer to "NAVIGATION AND MULTIMEDIA SYSTEM OWNER'S MANUAL".

■ Interior (right-hand drive vehicles)

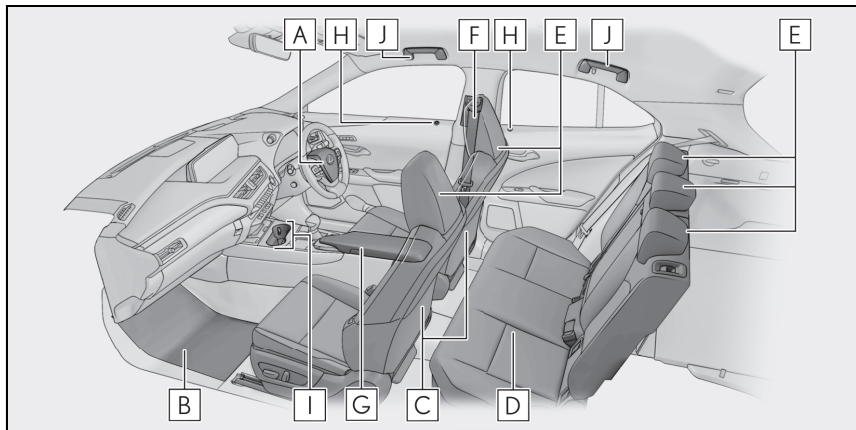

A	SRS airbags	P.38
B	Floor mats	P.32
C	Front seats	P.184
D	Rear seats	P.185
E	Head restraints	P.190
F	Seat belts	P.34
G	Console box	P.373
H	Inside lock buttons	P.136
I	Cup holders	P.373
J	Assist grips	P.387

■ Ceiling (right-hand drive vehicles)

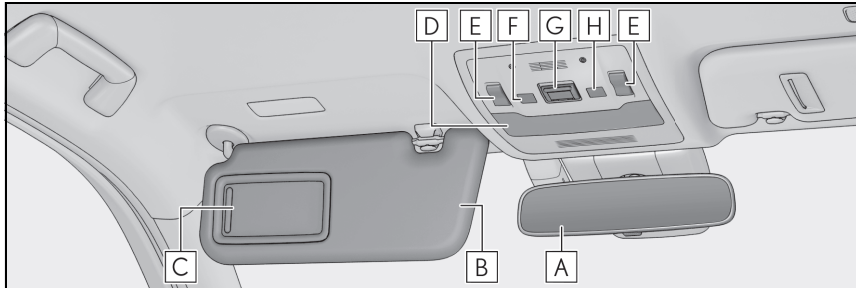

- A** Inside rear view mirrorP.193
- B** Sun visors ^{*1} P.380
- C** Vanity mirrors P.380
- D** Interior light ^{*2} P.370
 Personal lights.....P.371
- E** Moon roof switches ^{*3}P.199
- F** Intrusion sensor cancel switch ^{*3} P.99
 Intrusion sensor and tilt sensor cancel switch ^{*3} P.99
- G** "SOS" button.....P.64
- H** Door-linked interior light switch P.370

^{*1}: NEVER use a rearward facing child restraint on a seat protected by an ACTIVE AIR-BAG in front of it, DEATH or SERIOUS INJURY to the CHILD can occur. (→P.51)



^{*2}: The illustration shows the front, but they are also equipped in the rear.

^{*3}: If equipped

For safety and security

1

31

- 1-1. **For safe use**
 - Before driving32
 - For safe driving..... 33
 - Seat belts34
 - SRS airbags38
 - Exhaust gas precautions45
- 1-2. **Child safety**
 - Airbag manual on-off system...47
 - Riding with children48
 - Child restraint systems49
- 1-3. **Emergency assistance**
 - eCall64
 - ERA-GLONASS/EVAK.....80
- 1-4. **Theft deterrent system**
 - Engine immobilizer system84
 - Double locking system96
 - Alarm97

1
For safety and security

Before driving

Observe the following before starting off in the vehicle to ensure safety of driving.

Installing floor mats

Use only floor mats designed specifically for vehicles of the same model and model year as your vehicle. Fix them securely in place onto the carpet.

- 1 Insert the retaining hooks (clips) into the floor mat eyelets.

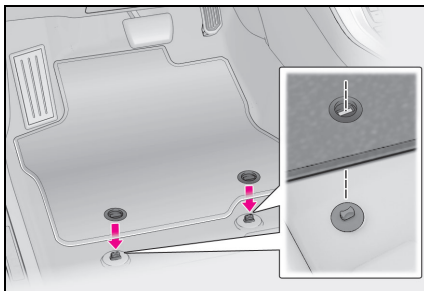

- 2 Turn the upper knob of each retaining hook (clip) to secure the floor mats in place.

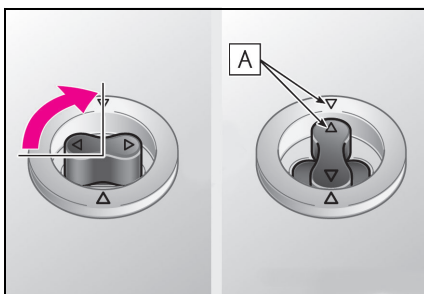

Always align the \triangle marks **A**.

The shape of the retaining hooks (clips) may differ from that shown in the illustration.

! WARNING

Observe the following precautions. Failure to do so may cause the driver's floor mat to slip, possibly interfering with the pedals while driving. An unexpectedly high speed may result or it may become difficult to stop the vehicle. This could lead to an accident, resulting in death or serious injury.

■ When installing the driver's floor mat

- Do not use floor mats designed for other models or different model year vehicles, even if they are Lexus Genuine floor mats.
- Only use floor mats designed for the driver's seat.
- Always install the floor mat securely using the retaining hooks (clips) provided.
- Do not use two or more floor mats on top of each other.
- Do not place the floor mat bottom-side up or upside-down.

■ Before driving

- Check that the floor mat is securely fixed in the correct place with all the provided retaining hooks (clips). Be especially careful to perform this check after cleaning the floor.

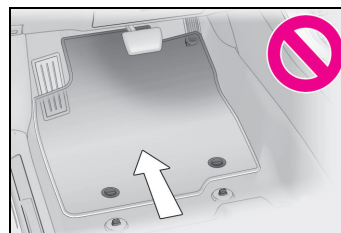

- With the engine stopped and the shift lever in P, fully depress each pedal to the floor to make sure it does not interfere with the floor mat.

For safe driving

For safe driving, adjust the seat and mirror to an appropriate position before driving.

Correct driving posture

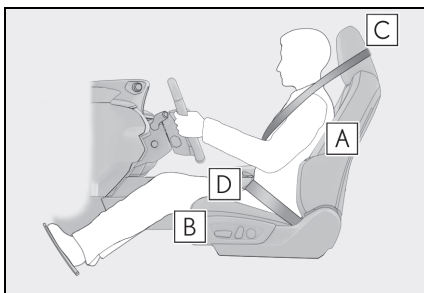

- A** Adjust the angle of the seatback so that you are sitting straight up and so that you do not have to lean forward to steer. (→P.184)
- B** Adjust the seat so that you can depress the pedals fully and so that your arms bend slightly at the elbow when gripping the steering wheel. (→P.184)
- C** Lock the head restraint in place with the center of the head restraint closest to the top of your ears. (→P.190)
- D** Wear the seat belt correctly. (→P.35)

WARNING

Observe the following precautions. Failure to do so may result in death or serious injury.

- Do not adjust the position of the driver's seat while driving. Doing so could cause the driver to lose control of the vehicle.
- Do not place a cushion between the driver or passenger and the seatback. A cushion may prevent correct posture from being achieved, and reduce the effectiveness of the seat belt and head restraint.
- Do not place anything under the front seats. Objects placed under the front seats may become jammed in the seat tracks and stop the seat from locking in place. This may lead to an accident and the adjustment mechanism may also be damaged.
- Always observe the legal speed limit when driving on public roads.
- When driving over long distances, take regular breaks before you start to feel tired. Also, if you feel tired or sleepy while driving, do not force yourself to continue driving and take a break immediately.

Correct use of the seat belts

Make sure that all occupants are wearing their seat belts before driving the vehicle. (→P.35)

Use a child restraint system appropriate for the child until the child becomes large enough to properly wear the vehicle's seat belt. (→P.49)

Adjusting the mirrors

Make sure that you can see the rear of the vehicle clearly, by adjusting the inside and outside rear view mirrors properly. (→P.193, 195)

Seat belts

Make sure that all occupants are wearing their seat belts before driving the vehicle.

WARNING

Observe the following precautions to reduce the risk of injury in the event of sudden braking, sudden swerving or an accident. Failure to do so may cause death or serious injury.

■ Wearing a seat belt

- Ensure that all passengers wear a seat belt.
- Always wear a seat belt properly.
- Each seat belt should be used by one person only. Do not use a seat belt for more than one person at once, including children.
- Lexus recommends that children be seated in the rear seat and always use a seat belt and/or an appropriate child restraint system.
- To achieve a proper seating position, do not recline the seat more than necessary. The seat belt is most effective when the occupants are sitting up straight and well back in the seats.
- Do not wear the shoulder belt under your arm.
- Always wear your seat belt low and snug across your hips.

■ Pregnant women

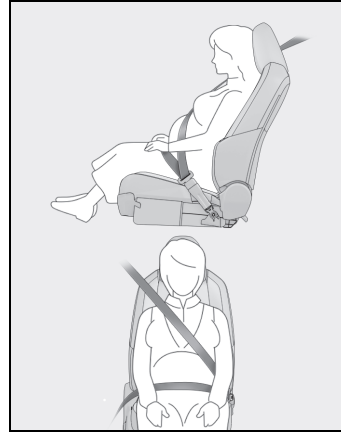

Obtain medical advice and wear the seat belt in the proper way. (→P.35)

Women who are pregnant should position the lap belt as low as possible over the hips in the same manner as other occupants, extending the shoulder belt completely over the shoulder and avoiding belt contact with the rounding of the abdominal area.

If the seat belt is not worn properly, not only the pregnant woman, but also the fetus could suffer death or serious injury as a result of sudden braking or a collision.

■ People suffering illness

Obtain medical advice and wear the seat belt in the proper way. (→P.35)

■ When children are in the vehicle

→P.61

■ Seat belt damage and wear

- Do not damage the seat belts by allowing the belt, plate, or buckle to be jammed in the door.

⚠ WARNING

- Inspect the seat belt system periodically. Check for cuts, fraying, and loose parts. Do not use a damaged seat belt until it is replaced. Damaged seat belts cannot protect an occupant from death or serious injury.
- Ensure that the belt and plate are locked and the belt is not twisted. If the seat belt does not function correctly, immediately contact any authorized Lexus retailer or Lexus authorized repairer, or any reliable repairer.
- Replace the seat assembly, including the belts, if your vehicle has been involved in a serious accident, even if there's no obvious damage.
- Do not attempt to install, remove, modify, disassemble or dispose of the seat belts. Have any necessary repairs carried out by any authorized Lexus retailer or Lexus authorized repairer, or any reliable repairer. Inappropriate handling may lead to incorrect operation.

Correct use of the seat belts

- Extend the shoulder belt so that it comes fully over the shoulder, but does not come into contact with the neck or slide off the shoulder.
- Position the lap belt as low as possible over the hips.
- Adjust the position of the seatback. Sit up straight and well back in the seat.



- Do not twist the seat belt.

Child seat belt usage

The seat belts of your vehicle were principally designed for persons of adult size.

- Use a child restraint system appropriate for the child, until the child becomes large enough to properly wear the vehicle's seat belt. (→P.49)
- When the child becomes large enough to properly wear the vehicle's seat belt, follow the instructions regarding seat belt usage. (→P.34)

Seat belt regulations

If seat belt regulations exist in the country where you reside, please contact any authorized Lexus retailer or Lexus authorized repairer, or any reliable repairer for seat belt replacement or installation.

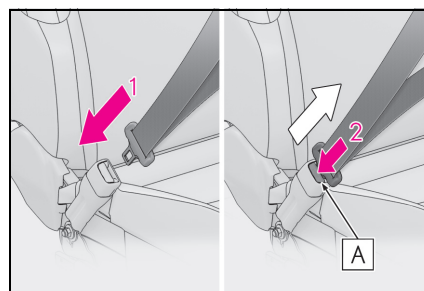
Fastening and releasing the seat belt

- 1 To fasten the seat belt, push the plate into the buckle until a click

sound is heard.

- 2 To release the seat belt, press the release button **A**.

■ Emergency locking retractor (ELR)

The retractor will lock the belt during a sudden stop or on impact. It may also lock if you lean forward too quickly. A slow, easy motion will allow the belt to extend so that you can move around fully.

Adjusting the seat belt shoulder anchor height (front seats)

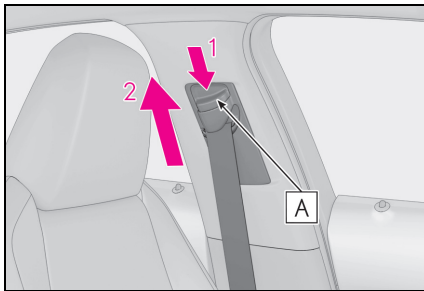

- 1 Push the seat belt shoulder anchor down while pressing the release button **A**.
- 2 Push the seat belt shoulder anchor up.

Move the height adjuster up and down as needed until you hear a click.

⚠ WARNING

■ Adjustable shoulder anchor

Always make sure the shoulder belt is positioned across the center of your shoulder. The belt should be kept away from your neck, but not falling off your shoulder. Failure to do so could reduce the amount of protection in an accident and cause death or serious injuries in the event of a sudden stop, sudden swerve or accident.

Seat belt pretensioners (front and outboard rear seats)

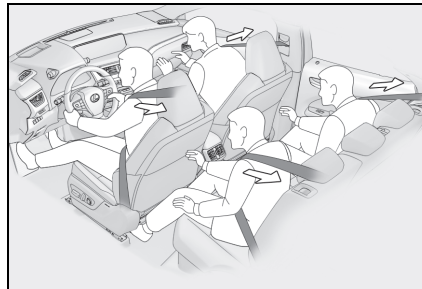

The pretensioners help the seat belts to quickly restrain the occupants by retracting the seat belts when the vehicle is subjected to certain types of severe frontal or side collision.

The pretensioners do not activate in the event of a minor frontal impact, a minor side impact, a rear impact or a vehicle roll-over.

■ Replacing the belt after the pretensioner has been activated

If the vehicle is involved in multiple collisions, the pretensioner will activate for the first collision, but will not activate for the second or subsequent collisions.

■ PCS-linked seat belt pretensioner control (vehicles with Lexus Safety System+)

If the PCS (Pre-Collision System) determines that the possibility of a collision with a vehicle is high, the seat belt pretensioners will be prepared to operate.

 **WARNING****■ Seat belt pretensioners**

If the pretensioner has activated, the SRS warning light will come on. In that case, the seat belt cannot be used again and must be replaced at any authorized Lexus retailer or Lexus authorized repairer, or any reliable repairer. Failure to do so may cause death or serious injury.

SRS airbags

The SRS airbags inflate when the vehicle is subjected to certain types of severe impacts that may cause significant injury to the occupants. They work together with the seat belts to help reduce the risk of death or serious injury.

SRS airbag system

■ Location of the SRS airbags

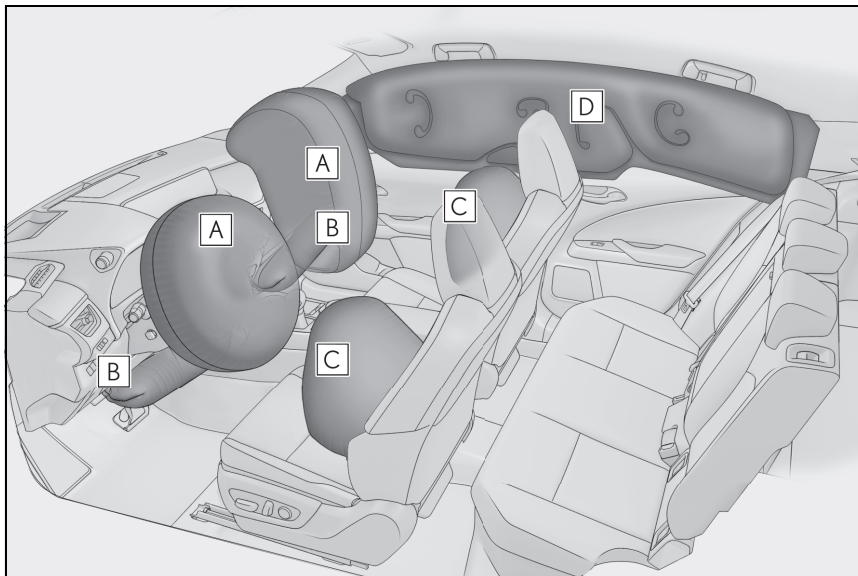

► SRS front airbags

A SRS driver airbag/front passenger airbag

Can help protect the head and chest of the driver and front passenger from impact with interior components

B SRS knee airbags

Can help provide driver and front passenger protection

► SRS side and curtain shield airbags

C SRS side airbags

Can help protect the torso and pelvis of the front seat occupants

D SRS curtain shield airbags

Can help protect primarily the head of occupants in the outer seats

■ SRS airbag system components

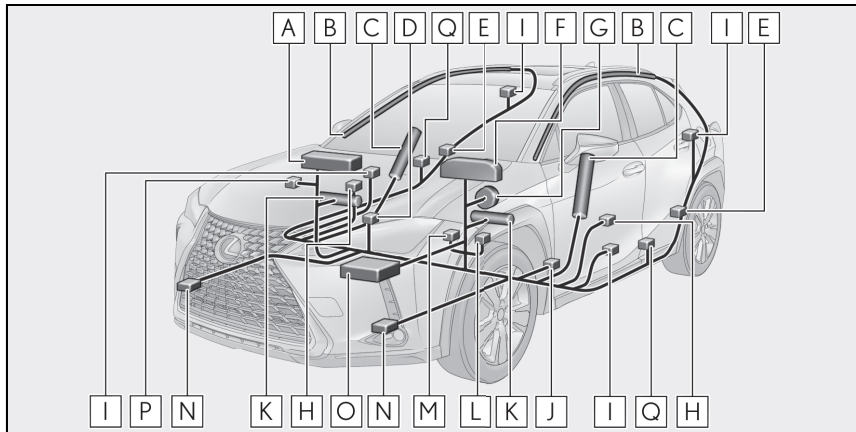

- A** Front passenger airbag
- B** Curtain shield airbags
- C** Side airbags
- D** "PASSENGER AIR BAG" indicator
- E** Side impact sensors (rear)
- F** SRS warning light
- G** Driver airbag
- H** Side impact sensors (front)
- I** Seat belt pretensioners and force limiters
- J** Driver's seat position sensor
- K** Knee airbags
- L** Driver's seat belt buckle switch
- M** Front passenger's seat belt buckle switch
- N** Front impact sensors
- O** Airbag sensor assembly
- P** Airbag manual on-off switch
- Q** Side impact sensors (front door)

The main SRS airbag system components are shown above. The SRS airbag sys-

tem is controlled by the airbag sensor assembly. As the airbags deploy, a chemical reaction in the inflators quickly fills the airbags with non-toxic gas to help restrain the motion of the occupants.

■ If the SRS airbags deploy (inflate)

- Slight abrasions, burns, bruising etc., may be sustained from SRS airbags, due to the extremely high speed deployment (inflation) by hot gases.
- A loud noise and white powder will be emitted.
- Parts of the airbag module (steering wheel hub, airbag cover and inflator) as well as the front seats, parts of the front and rear pillars, and roof side rails, may be hot for several minutes. The airbag itself may also be hot.
- The windshield may crack.
- All of the doors will be unlocked. (→P.135)
- The brakes and stop lights will be controlled automatically. (Vehicles with Secondary Collision Brake) (→P.340)
- The interior lights will turn on automatically. (→P.370)
- The emergency flashers will turn on automatically. (→P.436)
- Fuel supply to the engine will be stopped. (→P.443)
- Vehicles with ERA-GLONASS/EVAK: If the SRS airbags deploy, the system is designed to send an emergency call* to the ERA-GLONASS/EVAK control center, notifying them of the vehicle's location (without needing to push the "SOS" button) and an agent will attempt to speak with the occupants to ascertain the level of emergency and assistance required. If the occupants are unable to communicate, the agent automatically treats the call as an emergency and helps to dispatch the necessary emergency services. (→P.80)

*: In some cases, the call cannot be made. (→P.81)

■ SRS airbag deployment conditions (SRS front airbags)

- The SRS front airbags will deploy in the event of an impact that exceeds the set threshold level (the level of force corresponding to an approximately 20 - 30 km/h [12 - 18 mph] frontal collision with a fixed wall that does not move or deform). However, this threshold velocity will be considerably higher in the following situations:
 - If the vehicle strikes an object, such as a parked vehicle or sign pole, which can move or deform on impact
 - If the vehicle is involved in an underride collision, such as a collision in which the front of the vehicle underrides, or goes under, the bed of a truck
- Depending on the type of collision, it is possible that only the seat belt pretensioners will activate.

■ SRS airbag deployment conditions (SRS side and curtain shield airbags)

- The SRS side and curtain shield airbags will deploy in the event of an impact that exceeds the set threshold level (the level of force corresponding to the impact force produced by an approximately 1500 kg [3300 lb.] vehicle colliding with the vehicle cabin from a direction perpendicular to the vehicle orientation at an approximate speed of 20 - 30 km/h [12 - 18 mph]).
- Both SRS curtain shield airbags may deploy in the event of a severe side collision.
- Both SRS curtain shield airbags may also deploy in the event of a severe frontal collision.

■ Conditions under which the SRS airbags may deploy (inflate), other than a collision

The SRS front airbags and SRS curtain shield airbags may also deploy if a serious impact occurs to the underside of your

vehicle. Some examples are shown in the illustration.

- Hitting a curb, edge of pavement or hard surface
- Falling into or jumping over a deep hole
- Landing hard or falling

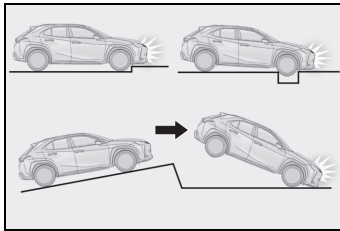

■ **Types of collisions that may not deploy the SRS airbags (SRS front airbags)**

The SRS front airbags do not generally inflate if the vehicle is involved in a side or rear collision, if it rolls over, or if it is involved in a low-speed frontal collision. But, whenever a collision of any type causes sufficient forward deceleration of the vehicle, deployment of the SRS front airbags may occur.

- Collision from the side
- Collision from the rear
- Vehicle rollover

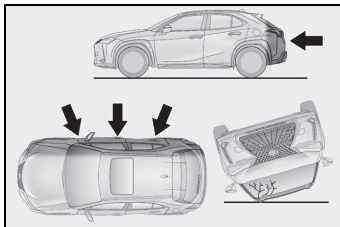

■ **Types of collisions that may not deploy the SRS airbags (SRS side and curtain shield airbags)**

The SRS side and curtain shield airbags may not activate if the vehicle is subjected to a collision from the side at certain angles, or a collision to the side of the vehicle body other than the passenger compartment.

- Collision from the side to the vehicle body other than the passenger compartment

- Collision from the side at an angle

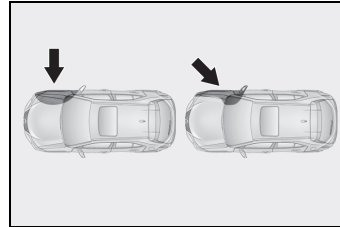

The SRS side airbags do not generally inflate if the vehicle is involved in a frontal or rear collision, if it rolls over, or if it is involved in a low-speed side collision.

- Collision from the front
- Collision from the rear
- Vehicle rollover

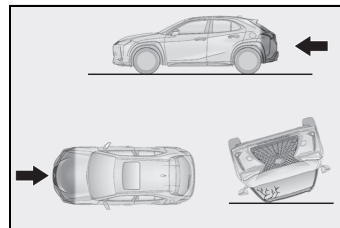

The SRS curtain shield airbags do not generally inflate if the vehicle is involved in a rear collision, if it rolls over, or if it is involved in a low-speed side or low-speed frontal collision.

- Collision from the rear
- Vehicle rollover

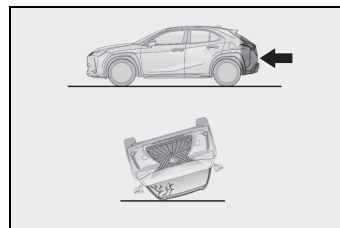

■ **When to contact any authorized Lexus retailer or Lexus authorized repairer, or any reliable repairer**

In the following cases, the vehicle will require inspection and/or repair. Contact any authorized Lexus retailer or Lexus

authorized repairer, or any reliable repairer as soon as possible.

- Any of the SRS airbags have been inflated.
- The front of the vehicle is damaged or deformed, or was involved in an accident that was not severe enough to cause the SRS front airbags to inflate.

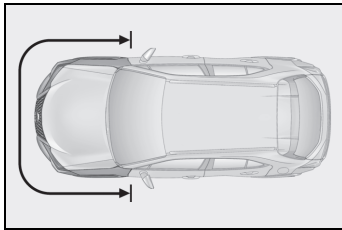

- A portion of a door or its surrounding area is damaged, deformed or has had a hole made in it, or the vehicle was involved in an accident that was not severe enough to cause the SRS side and curtain shield airbags to inflate.

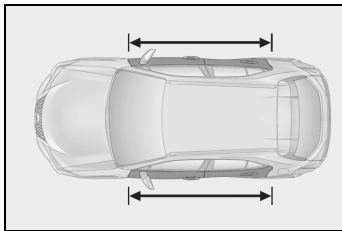

- The pad section of the steering wheel, dashboard near the front passenger airbag or lower portion of the instrument panel is scratched, cracked, or otherwise damaged.

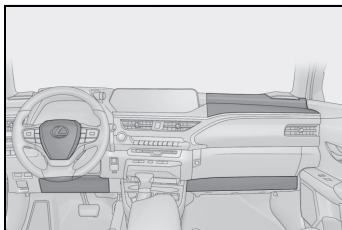

- The surface of the seats with the side airbag is scratched, cracked, or otherwise damaged.

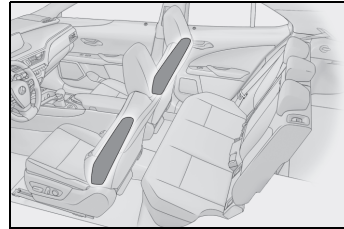

- The portion of the front pillars, rear pillars or roof side rail garnishes (padding) containing the SRS curtain shield airbags inside is scratched, cracked, or otherwise damaged.

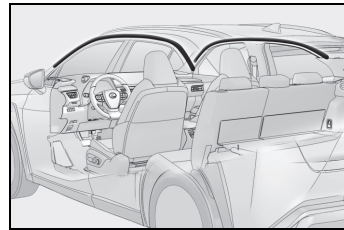

⚠ WARNING

■ SRS airbag precautions

Observe the following precautions regarding the SRS airbags. Failure to do so may cause death or serious injury.

- The driver and all passengers in the vehicle must wear their seat belts properly. The SRS airbags are supplemental devices to be used with the seat belts.

WARNING

- The SRS driver airbag deploys with considerable force, and can cause death or serious injury especially if the driver is very close to the airbag. Since the risk zone for the driver's airbag is the first 50 - 75 mm (2 - 3 in.) of inflation, placing yourself 250 mm (10 in.) from your driver airbag provides you with a clear margin of safety. This distance is measured from the center of the steering wheel to your breastbone. If you sit less than 250 mm (10 in.) away now, you can change your driving position in several ways:
 - Move your seat to the rear as far as you can while still reaching the pedals comfortably.
 - Slightly recline the back of the seat. Although vehicle designs vary, many drivers can achieve the 250 mm (10 in.) distance, even with the driver seat all the way forward, simply by reclining the back of the seat somewhat. If reclining the back of your seat makes it hard to see the road, raise yourself by using a firm, non-slippery cushion, or raise the seat if your vehicle has that feature.
 - If your steering wheel is adjustable, tilt it downward. This points the airbag toward your chest instead of your head and neck.

The seat should be adjusted as recommended above, while still maintaining control of the foot pedals, steering wheel, and your view of the instrument panel controls.

- The SRS front passenger airbag also deploys with considerable force, and can cause death or serious injury especially if the front passenger is very close to the airbag. The front passenger seat should be as far from the airbag as possible with the seatback adjusted, so the front passenger sits upright.

- Improperly seated and/or restrained infants and children can be killed or seriously injured by a deploying airbag. An infant or child who is too small to use a seat belt should be properly secured using a child restraint system. Lexus strongly recommends that all infants and children be placed in the rear seats of the vehicle and properly restrained. The rear seats are safer for infants and children than the front passenger seat. (→P.49)

- Do not sit on the edge of the seat or lean against the dashboard.

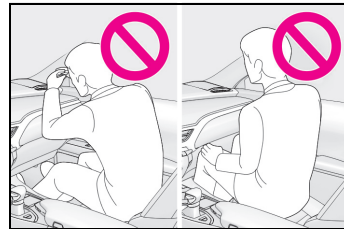

- Do not allow a child to stand in front of the SRS front passenger airbag unit or sit on the knees of a front passenger.
- Do not allow the front seat occupants to hold items on their knees.

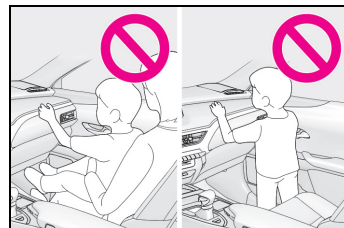

- Do not lean against the door, the roof side rail or the front, side and rear pillars.



⚠ WARNING

- Do not allow anyone to kneel on the passenger seat toward the door or put their head or hands outside the vehicle.



- Do not attach anything to or lean anything against areas such as the dashboard, steering wheel pad and lower portion of the instrument panel. These items can become projectiles when the SRS driver, front passenger and knee airbags deploy.

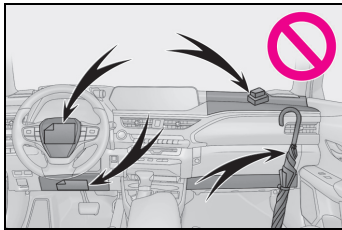

- Do not attach anything to areas such as a door, windshield, side windows, front or rear pillar, roof side rail and assist grip. (Except for the speed limit sticker →P.460)

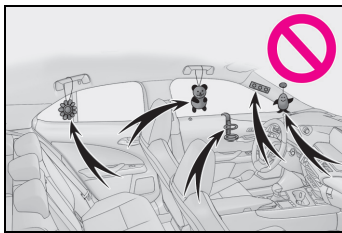

- Do not hang coat hangers or other hard objects on the coat hooks. All of these items could become projectiles and may cause death or serious injury, should the SRS curtain shield airbags deploy.
- If a vinyl cover is put on the area where the SRS knee airbag will deploy, be sure to remove it.
- Do not use seat accessories which cover the parts where the SRS side airbags inflate as they may interfere with inflation of the SRS airbags. Such accessories may prevent the side airbags from activating correctly, disable the system or cause the side airbags to inflate accidentally, resulting in death or serious injury.
- Do not strike or apply significant levels of force to the area of the SRS airbag components or the front doors. Doing so can cause the SRS airbags to malfunction.
- Do not touch any of the component parts immediately after the SRS airbags have deployed (inflated) as they may be hot.
- If breathing becomes difficult after the SRS airbags have deployed, open a door or window to allow fresh air in, or leave the vehicle if it is safe to do so. Wash off any residue as soon as possible to prevent skin irritation.
- If the areas where the SRS airbags are stored, such as the steering wheel pad and front and rear pillar garnishes, are damaged or cracked, have them replaced by any authorized Lexus retailer or Lexus authorized repairer, or any reliable repairer.

⚠ WARNING**■ Modification and disposal of SRS air-bag system components**

Do not dispose of your vehicle or perform any of the following modifications without consulting any authorized Lexus retailer or Lexus authorized repairer, or any reliable repairer. The SRS airbags may malfunction or deploy (inflate) accidentally, causing death or serious injury.

- Installation, removal, disassembly and repair of the SRS airbags
- Repairs, modifications, removal or replacement of the steering wheel, instrument panel, dashboard, seats or seat upholstery, front, side and rear pillars, roof side rails, front door panels, front door trims or front door speakers
- Modifications to the front door panel (such as making a hole in it)
- Repairs or modifications of the front fender, front bumper, or side of the occupant compartment
- Installation of a grille guard (bull bars, kangaroo bar, etc.), snow plows or winches
- Modifications to the vehicle's suspension system
- Installation of electronic devices such as mobile two-way radios (RF-transmitter) and CD players

Exhaust gas precautions

Harmful substances to the human body are contained in exhaust gases if inhaled.

⚠ WARNING

Exhaust gases contain harmful carbon monoxide (CO), which is colorless and odorless. Observe the following precautions.

Failure to do so may cause exhaust gases enter the vehicle and may lead to an accident caused by light-headedness, or may lead to death or a serious health hazard.

■ Important points while driving

- Keep the back door closed.
- If you smell exhaust gases in the vehicle even when the back door is closed, open the windows and have the vehicle inspected at any authorized Lexus retailer or Lexus authorized repairer, or any reliable repairer as soon as possible.

■ When parking

- If the vehicle is in a poorly ventilated area or a closed area, such as a garage, stop the engine.
- Do not leave the vehicle with the engine running for a long time. If such a situation cannot be avoided, park the vehicle in an open space and ensure that exhaust fumes do not enter the vehicle interior.
- Do not leave the engine running in an area with snow build-up, or where it is snowing. If snowbanks build up around the vehicle while the engine is running, exhaust gases may collect and enter the vehicle.

**WARNING****■ Exhaust pipe**

The exhaust system needs to be checked periodically. If there is a hole or crack caused by corrosion, damage to a joint or abnormal exhaust noise, be sure to have the vehicle inspected and repaired by any authorized Lexus retailer or Lexus authorized repairer, or any reliable repairer.

Airbag manual on-off system

This system deactivates the front passenger airbag and front passenger knee airbag.

Only deactivate the airbags when using a child restraint system on the front passenger seat.

System components

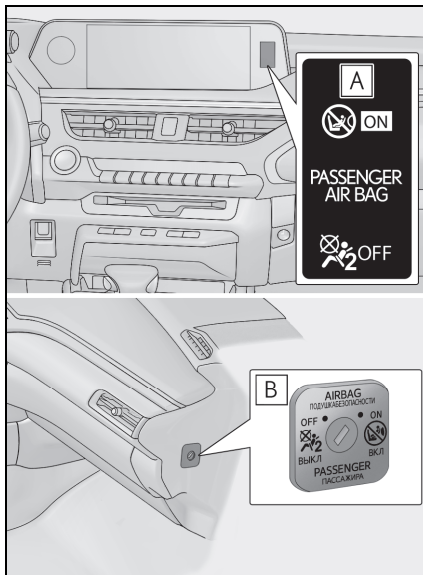

A "PASSENGER AIR BAG" indicator

"PASSENGER AIR BAG" and "ON" indicator light turn on when the airbag system is on, and about after 60 seconds they go off (only when the engine switch is in ON).

B Airbag manual on-off switch

Deactivating the airbags for the front passenger

Insert the mechanical key into the cylinder and turn to the "OFF" position.

The "OFF" indicator light turns on (only when the engine switch is in ON).

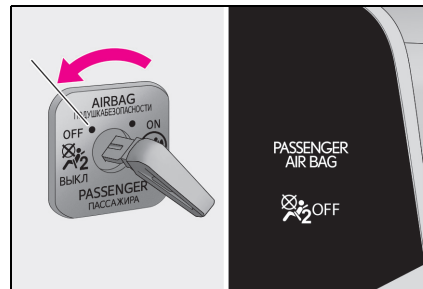

"PASSENGER AIR BAG" indicator information

If any of the following problems occur, it is possible that there is a malfunction in the system. Have the vehicle inspected by any authorized Lexus retailer or Lexus authorized repairer, or any reliable repairer.

- The "OFF" indicator does not illuminate when the airbag manual on-off switch is set to "OFF".
- The indicator light does not change when the airbag manual on-off switch is switched to "ON" or "OFF".

⚠ WARNING

■ When installing a child restraint system

For safety reasons, always install a child restraint system in a rear seat. In the event that the rear seat cannot be used, the front seat can be used as long as the airbag manual on-off system is set to "OFF".

If the airbag manual on-off system is left on, the strong impact of the airbag deployment (inflation) may cause serious injury or even death.

**WARNING****■ When a child restraint system is not installed on the front passenger seat**

Ensure that the airbag manual on-off system is set to "ON".

If it is left off, the airbag may not deploy in the event of an accident, which may result in serious injury or even death.

Riding with children

Observe the following precautions when children are in the vehicle.

Use a child restraint system appropriate for the child, until the child becomes large enough to properly wear the vehicle's seat belt.

- It is recommended that children sit in the rear seats to avoid accidental contact with the shift lever, wiper switch, etc.
- Use the rear door child-protector lock or the window lock switch to avoid children opening the door while driving or operating the power window accidentally. (→P.137, 199)
- Do not let small children operate equipment which may catch or pinch body parts, such as the power window, hood, back door, seats, etc.

**WARNING****■ When children are in the vehicle**

Never leave children unattended in the vehicle, and never allow children to have or use the key.

Children may be able to start the vehicle or shift the vehicle into neutral. There is also a danger that children may injure themselves by playing with the windows, the moon roof (if equipped) or other features of the vehicle. In addition, heat build-up or extremely cold temperatures inside the vehicle can be fatal to children.

Child restraint systems

Before installing a child restraint system in the vehicle, there are precautions that need to be observed, different types of child restraint systems, as well as installation methods, etc., written in this manual.

- Use a child restraint system when riding with a small child that cannot properly use a seat belt. For the child's safety, install the child restraint system to a rear seat. Be sure to follow the installation method that is in the operation manual enclosed with the restraint system.
- The use of a Lexus genuine child restraint system is recommended, as it is safer to use in this vehicle. Lexus genuine child restraint systems are made specifically for Lexus vehicles. They can be purchased at a Lexus dealer.

Table of contents

Points to remember: P.49

When using a child restraint system: P.50

Child restraint system compatibility for each seating position: P.53

Child restraint system installation method: P.59

- Fixed with a seat belt: P.59
- Fixed with an ISOFIX lower anchorage: P.61

- Using a top tether anchorage: P.62

Points to remember

- Prioritize and observe the warnings, as well as the laws and regulations for child restraint systems.
- Use a child restraint system until the child becomes large enough to properly wear the vehicle's seat belt.
- Choose a child restraint system appropriate to the age and size of the child.
- Note that not all child restraint systems can fit in all vehicles. Before using or purchasing a child restraint system, check the compatibility of the child restraint system with seat positions.

WARNING

■ When a child is riding

Observe the following precautions. Failure to do so may result in death or serious injury.

- For effective protection in automobile accidents and sudden stops, a child must be properly restrained, using a seat belt or child restraint system which is correctly installed. For installation details, refer to the operation manual enclosed with the child restraint system. General installation instruction is provided in this manual.
- Lexus strongly urges the use of a proper child restraint system that conforms to the weight and size of the child, installed on the rear seat. According to accident statistics, the child is safer when properly restrained in the rear seat than in the front seat.

WARNING

- Holding a child in your or someone else's arms is not a substitute for a child restraint system. In an accident, the child can be crushed against the windshield or between the holder and the interior of the vehicle.

■ Handling the child restraint system

If the child restraint system is not properly fixed in place, the child or other passengers may be seriously injured or even killed in the event of sudden braking, sudden swerving, or an accident.

- If the vehicle were to receive a strong impact from an accident, etc., it is possible that the child restraint system has damage that is not readily visible. In such cases, do not reuse the restraint system.
- Depending on the child restraint system, installation may be difficult or impossible. In those cases, check whether the child restraint system is suitable for installment in the vehicle. (→P.53) Be sure to install and observe the usage rules after carefully reading the child restraint system fixing method in this manual, as well as the operation manual enclosed with the child restraint system.
- Keep the child restraint system properly secured on the seat even if it is not in use. Do not store the child restraint system unsecured in the passenger compartment.
- If it is necessary to detach the child restraint system, remove it from the vehicle or store it securely in the luggage compartment.

When using a child restraint system

■ When installing a child restraint system to the front passenger seat

For the safety of a child, install a child restraint system to a rear seat. When installing a child restraint system to the front passenger seat is unavoidable, adjust the seat as follows and install the child restraint system:

- Adjust the seatback angle to the most upright position.

When installing a forward-facing child seat, if there is a gap between the child seat and the seatback, adjust the seatback angle until good contact is achieved.

- Adjust the seat height to the uppermost position.
- Move the front seat fully rearward.
- Vehicles with power seat: Adjust the front of the seat cushion to the lowest position.
- If the head restraint interferes with the child restraint system installation and the head restraint can be removed, remove the head restraint. Otherwise, put the head restraint in the upper most position.

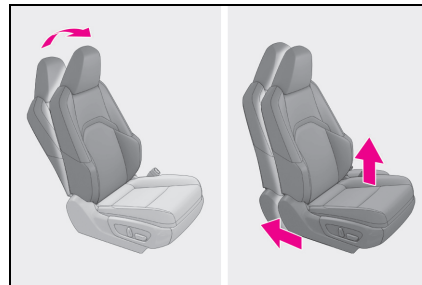

⚠ WARNING**■ When using a child restraint system**

Observe the following precautions.
Failure to do so may result in death or serious injury.

- Never use a rear-facing child restraint system on the front passenger seat when the airbag manual on-off switch is on. (→P.47)
The force of the rapid inflation of the front passenger airbag can cause death or serious injury to children in the event of an accident.

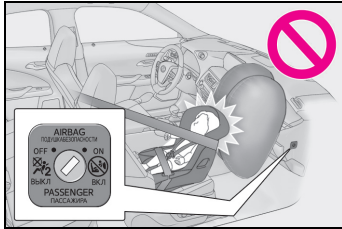

- There is a label(s) on the passenger side sun visor, indicating it is forbidden to attach a rear-facing child restraint system to the front passenger seat. Details of the label(s) are shown in the illustration below.

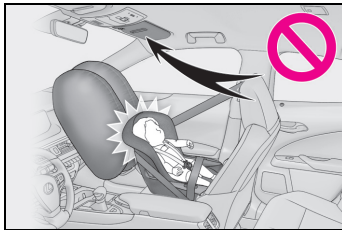

⚠ WARNING



⚠ WARNING

- Only put a forward-facing child restraint system on the front seat when unavoidable. When installing a forward-facing child restraint on the front passenger seat, move the seat as far back as possible. Failing to do so may result in death or serious injury if the airbags deploy (inflate).

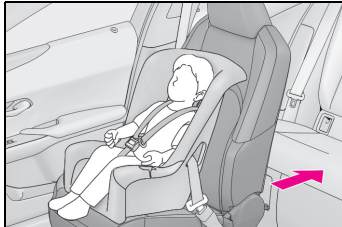

- Do not allow the child to lean his/her head or any part of his/her body against the door or the area of the seat, front or rear pillars, or roof side rails from which the SRS side airbags or SRS curtain shield airbags deploy even if the child is seated in the child restraint system. It is dangerous if the SRS side and curtain shield airbags inflate, and the impact could cause death or serious injury to the child.



- When a junior seat is installed, always ensure that the shoulder belt is positioned across the center of the child's shoulder. The belt should be kept away from the child's neck, but not so that it could fall off the child's shoulder.
- Use a child restraint system suitable to the age and size of the child and install it to the rear seat.

! WARNING

- If the driver's seat interferes with the child restraint system and prevents it from being attached correctly, attach the child restraint system to the right-hand rear seat (left-hand drive vehicles) or the left-hand rear seat (right-hand drive vehicles). (→P.57)

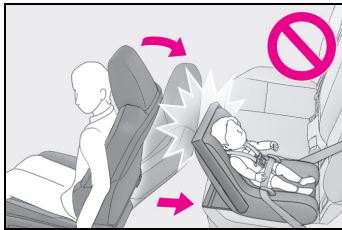
**Child restraint system compatibility for each seating position****■ Child restraint system compatibility for each seating position**

Compatibility of each seating position with child restraint systems (→P.54) displays the type of child restraint systems that can be used and possible seating positions for installation using symbols.

Also, the recommended child restraint system that is suitable for your child can be selected. Otherwise, check "Recommended child restraint systems and Compatibility table" for recommended child restraint systems. (→P.57)

Check the selected child restraint system together with the following "Before confirming the compatibility of each seating position with child restraint systems".

■ Before confirming the compatibility of each seating position with child restraint systems

- 1 Check the child restraint system standards.

Use a child restraint system that conforms to UN(ECE) R44*¹ or UN(ECE) R129*^{1,2}.

The following approval mark is displayed on child restraint systems which are conformed.

Check for an approval mark attached to the child restraint system.

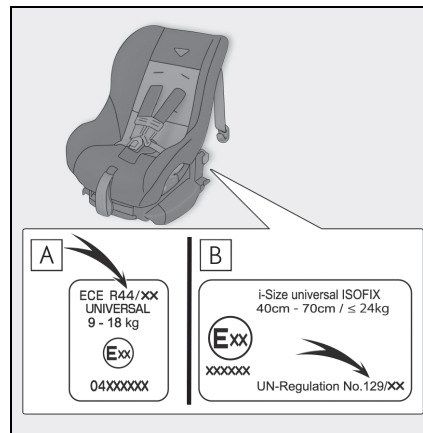

Example of the displayed regulation Number

- A** UN(ECE) R44 approval mark*³
The weight range of the child who is applicable for an UN(ECE) R44 approval mark is indicated.
- B** UN(ECE) R129 approval mark*³
The height range of the child who is applicable as well as available weights for an UN(ECE) R129 approval mark is indicated.

- 2** Check the category of the child restraint system.
 Check the approval mark of the child restraint system for which of the following categories the child restraint system is suitable.
 Also, if there are any uncertainties, check the user's guide included with the child restraint system or contact the retailer of the child restraint system.
- "universal"
 - "semi-universal"
 - "restricted"
 - "vehicle specific"

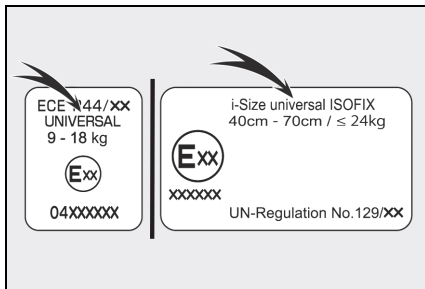

*1: UN(ECE) R44 and UN(ECE) R129 are U.N. regulations for child restraint systems.
 *2: The child restraint systems mentioned in the table may not be available outside of the EU area.
 *3: The displayed mark may differ depending on the product.

■ **Compatibility of each seating position with child restraint systems**



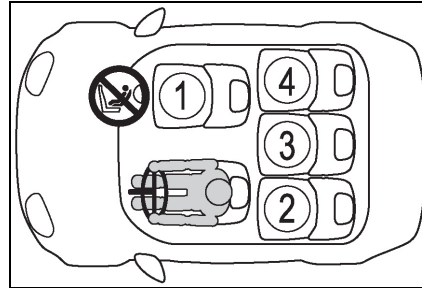



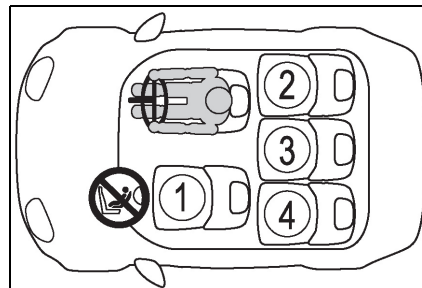

▶ Left-hand drive vehicles



▶ Right-hand drive vehicles



① ^{*1, 2, 3}	<div style="display: flex; flex-direction: column; align-items: center;"> <div style="border: 1px solid black; padding: 2px; margin-bottom: 2px;">U^{*4}</div> <div style="border: 1px solid black; padding: 2px; margin-bottom: 2px;">L</div> </div>
② ^{*3}	<div style="display: flex; flex-direction: column; align-items: center;"> <div style="border: 1px solid black; padding: 2px; margin-bottom: 2px;">U</div> <div style="border: 1px solid black; padding: 2px; margin-bottom: 2px;">L</div> <div style="border: 1px solid black; padding: 2px; margin-bottom: 2px;">i</div> <div style="border: 1px solid black; padding: 2px; margin-bottom: 2px;">i</div> </div>

③ ^{*3}	   
④ ^{*3}	   



Suitable for “universal” category child restraint system fixed with the seat belt.



Suitable for child restraint systems given on recommended child restraint systems and compatibility table (→P. 57).



Suitable for i-Size and ISOFIX child restraint system.



Includes a top tether anchorage point.



Never use a rear-facing child restraint system on the front passenger seat when the airbag manual on-off switch is on.

^{*1}: Move the front seat fully rearward. If the passenger seat height can be adjusted, move it to the upper most position.

^{*2}: Adjust the seatback angle to the most upright position. When installing a forward-facing child seat, if there is a gap between the child seat and the seatback, adjust the seatback angle until good contact is achieved.

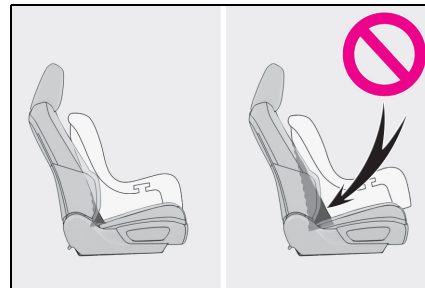

^{*3}: If the head restraint interferes with your child restraint system, and the head restraint can be removed, remove the head restraint.

Otherwise, put the head restraint in the upper most position.

^{*4}: Use only a front-facing child restraint system when the airbag manual on-off switch is on.

■ Detail information for child restraint systems installation

Seating position					
Seat position number	①		②	③	④
	Airbag manual on-off switch				
	ON	OFF			
Seating position suitable for universal belted (Yes/No)	Yes Forward-facing only	Yes	Yes	Yes	Yes
i-Size seating position (Yes/No)	No	No	Yes	No	Yes
Seating position suitable for lateral fixture (L1/L2/No)	No	No	No	No	No
Suitable rearward facing fixture (R1/R2X/R2/R3/No)	No	No	R1, R2X, R2, R3	No	R1, R2X, R2, R3
Suitable forward facing fixture (F2X/F2/F3/No)	No	No	F2X, F2, F3	No	F2X, F2, F3
Suitable junior seat fixture (B2/B3/No)	No	No	B2, B3	No	B2, B3

ISOFIX child restraint systems are divided into different “fixture”. The child restraint system can be used in the seating positions for “fixture” mentioned in the table above. For kind of “fixture”, confirm the following table.

If your child restraint system has no kind of “fixture” (or if you cannot find information in the table below), please refer to the child restraint system “vehicle list” for compatibility information or ask the retailer of your child seat.

Fixture	Description
F3	Full-height, forward-facing child restraint systems
F2	Reduced-height forward-facing child restraint systems
F2X	Reduced-height forward-facing child restraint systems
R3	Full-size, rearward-facing child restraint systems
R2	Reduced-size, rearward-facing child restraint systems

Fixture	Description
R2X	Reduced-size, rearward-facing child restraint systems
R1	Rearward-facing infant seat
L1	Left lateral-facing (carrycot) infant seat
L2	Right lateral-facing (carrycot) infant seat
B2	Junior seat
B3	Junior seat

■ Recommended child restraint systems and Compatibility table

Mass groups	Recommended Child Restraint System	Seating position				
		①		②	③	④
		Airbag manual on-off switch				
ON	OFF					
0, 0+ Up to 13 kg (28 lb.)	GO+, BABY SAFE PLUS (Yes/No)	No	Yes	Yes	Yes	Yes
	GO+ BABY SAFE PLUS with SEAT BELT FIXATION, BASE PLATFORM (Yes/No)	No	Yes	Yes	Yes	Yes
	LEXUS MINI (Yes/No)	No	Yes	Yes	Yes	Yes
	LEXUS MINI with ISO-BASE (Yes/No)	No	No	Yes	No	Yes
	LEXUS MIDI (Yes/No)	No	No	Yes	No	Yes
I 9 to 18 kg (20 to 39 lb.)	LEXUS DUO PLUS (Yes/No)	Yes Belt Fix Only	Yes Belt Fix Only	Yes	Yes Belt Fix Only	Yes
	LEXUS MIDI (Yes/No)	No	No	Yes	No	Yes

Mass groups	Recommended Child Restraint System	Seating position				
		①		②	③	④
		Airbag manual on-off switch				
ON	OFF					
II, III 15 to 36 kg (34 to 79 lb.)	KIDFIX XP SICT (Yes/No)	Yes Belt Fix Only	Yes Belt Fix Only	Yes	No	Yes
	MAXI PLUS (Yes/No)	Yes Belt Fix Only	Yes Belt Fix Only	Yes	No	Yes

The child restraint systems mentioned in the table may not be available outside the EU area.

When securing some types of child restraint systems in rear seat, it may not be possible to properly use the seat belts in positions next to the child restraint without interfering with it or affecting seat belt effectiveness. Be sure your seat belt fits snugly across your shoulder and low on your hips. If it does not, or if it interferes with the child restraint, move to a different position. Failure to do so may result in death or serious injury.

- When installing a child restraint in the rear seats, adjust the front seat so that it does not interfere with the child or child restraint system.
- When installing a child seat with support base, if the child seat interferes with the seatback when latching it into the support base, adjust the seatback rearward until there is no interference.

- If the seat belt shoulder anchor is ahead of the child seat belt guide, move the seat cushion forward.

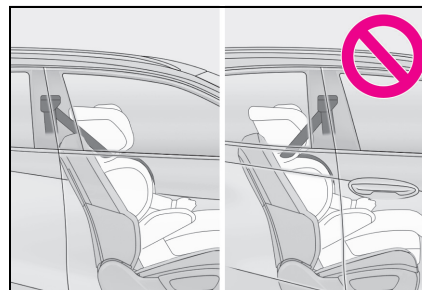

- When installing a junior seat, if the child in your child restraint system is in a very upright position, adjust the seatback angle to the most comfortable position. And if the seat belt shoulder anchor is ahead of the child seat belt guide, move the seat cushion forward.

Child restraint system installation method

Confirm with the operation manual enclosed with the child restraint system about the installation of the child restraint system.

	Installation method	Page
Seat belt attachment		P.59
ISOFIX lower anchorage attachment		P.61
Top tether anchorage attachment		P.62

Child restraint system fixed with a seat belt

■ Installing child restraint system using a seat belt

Install the child restraint system in

accordance to the operation manual enclosed with the child restraint system.

If the child restraint system on hand is not within the “universal” category (or the necessary information is not in the

table), refer to the “Vehicle List” provided by the child restraint system maker for various possible installation positions, or check the compatibility after asking the retailer of the child seat. (→P.53)

- 1 If installing the child restraint system to the front passenger seat is unavoidable, refer to P.50 for front passenger seat adjustment.
- 2 If the head restraint interferes with the child restraint system and the head restraint can be removed, remove the head restraint. Otherwise, put the head restraint in the upper most position. (→P.190)
- 3 Run the seat belt through the child restraint system and insert the plate into the buckle. Make sure that the belt is not twisted. Securely fix the seat belt to the child restraint system in accordance to the directions enclosed with the child restraint system.



- 4 If your child restraint system is not equipped with a lock-off (a seat belt

locking feature), secure the child restraint system using a locking clip.

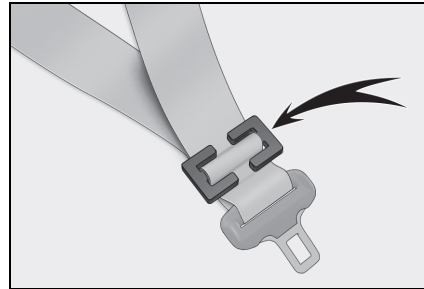

- 5 After installing the child restraint system, rock it back and forth to ensure that it is installed securely. (→P.61)

■ **Removing a child restraint system installed with a seat belt**

Press the buckle release button and fully retract the seat belt.

When releasing the buckle, the child restraint system may spring up due to the rebound of the seat cushion. Release the buckle while holding down the child restraint system.

Since the seat belt automatically reels itself, slowly return it to the stowing position.

■ **When installing a child restraint system**

You may need a locking clip to install the child restraint system. Follow the instructions provided by the manufacturer of the system. If your child restraint system does not provide a locking clip, you can purchase the following item from any authorized Lexus retailer or Lexus authorized repairer, or any reliable repairer: Locking clip for child restraint system (Part No. 73119-22010)

⚠ WARNING**■ When installing a child restraint system**

Observe the following precautions. Failure to do so may result in death or serious injury.

- Do not allow children to play with the seat belt. If the seat belt becomes twisted around a child's neck, it may lead to choking or other serious injuries that could result in death. If this occurs and the buckle cannot be unfastened, scissors should be used to cut the belt.
- Ensure that the belt and plate are securely locked and the seat belt is not twisted.
- Shake the child restraint system left and right, and forward and backward to ensure that it has been securely installed.
- After securing a child restraint system, never adjust the seat.
- When a junior seat is installed, always ensure that the shoulder belt is positioned across the center of the child's shoulder. The belt should be kept away from the child's neck, but not so that it could fall off the child's shoulder.
- Follow all installation instructions provided by the child restraint system manufacturer.

Child restraint system fixed with an ISOFIX lower anchorage**■ ISOFIX lower anchorages (ISOFIX child restraint system)**

Lower anchorages are provided for the outboard rear seats. (Marks displaying the location of the anchorages are attached to the seats.)

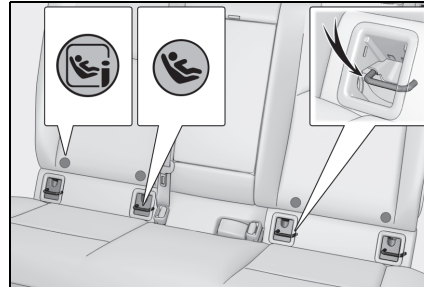
**■ Installation with ISOFIX lower anchorage (ISOFIX child restraint system)**

Install the child restraint system in accordance to the operation manual enclosed with the child restraint system.

If the child restraint system on hand is not within the "universal" category (or the necessary information is not in the table), refer to the "Vehicle List" provided by the child restraint system maker for various possible installation positions, or check the compatibility after asking the retailer of the child seat. (→P.53)

- 1 If the head restraint interferes with the child restraint system and the head restraint can be removed, remove the head restraint. Otherwise, put the head restraint in the upper most position. (→P.190)
- 2 Remove the anchorage covers, and install the child restraint system to the seat.

The bars are installed behind the anchor-

age covers.

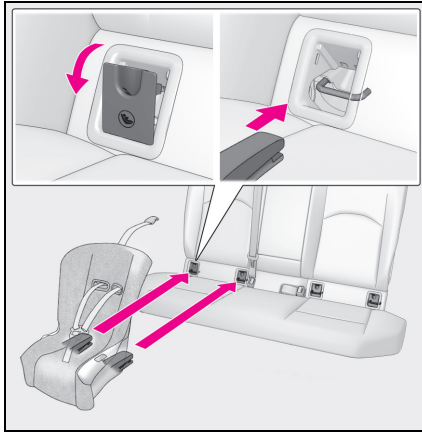

- After installing the child restraint system, rock it back and forth to ensure that it is installed securely. (→P.61)

⚠ WARNING

■ **When installing a child restraint system**

Observe the following precautions. Failure to do so may result in death or serious injury.

- After securing a child restraint system, never adjust the seat.
- When using the lower anchorages, be sure that there are no foreign objects around the anchorages and that the seat belt is not caught behind the child restraint system.
- Follow all installation instructions provided by the child restraint system manufacturer.

Using a top tether anchorage

■ **Top tether anchorages**

Top tether anchorages are provided for the outboard rear seats.

Use top tether anchorages when fixing the top strap.

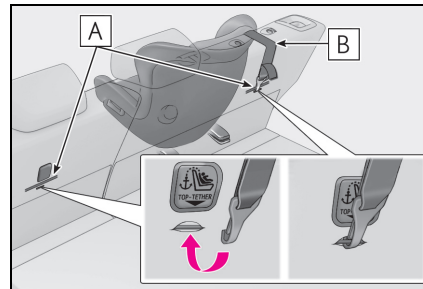

A Top tether anchorages

B Top strap

■ **Fixing the top strap to the top tether anchorage**

Install the child restraint system in accordance to the operation manual enclosed with the child restraint system.

- If the head restraint interferes with the child restraint system and the head restraint can be removed, remove the head restraint. Otherwise, put the head restraint in the upper most position. (→P.190)

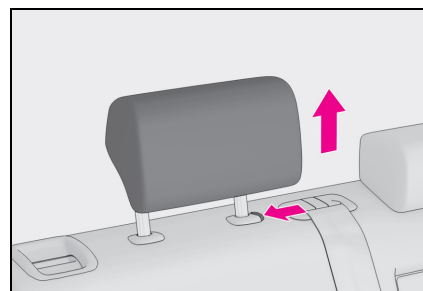

- Latch the hook onto the top tether anchorage and tighten the top strap.

Make sure the top strap is securely latched. (→P.61)

When installing the child restraint system with the head restraint raised, be sure to have the top strap pass underneath the head restraint.

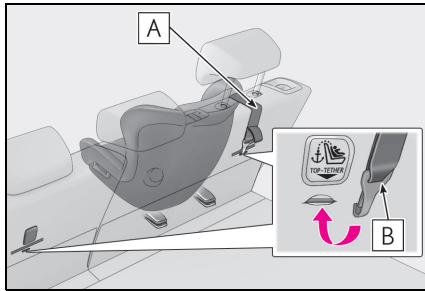

A Top strap

B Hook

⚠ WARNING

■ When installing a child restraint system

Observe the following precautions. Failure to do so may result in death or serious injury.

- Firmly attach the top strap and make sure that the belt is not twisted.
- Do not attach the top strap to anything other than the top tether anchorage.
- After securing a child restraint system, never adjust the seat.
- Follow all installation instructions provided by the child restraint system manufacturer.
- When installing the child restraint system with the head restraint being raised, after the head restraint has been raised and then the top tether anchorage has been fixed, do not lower the head restraint.

eCall*^{1, 2}

- *¹: If equipped
- *²: Operates within the eCall coverage.
The system name differs depending on the country.

eCall is a telematics service that uses Global Navigation Satellite System (GNSS) data and embedded cellular technology to enable the following emergency calls to be made: Automatic emergency calls (Automatic Collision Notification) and manual emergency calls (by pressing the “SOS” button). This service is required by European Union Regulations.

System components

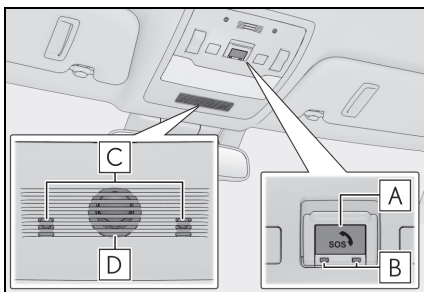

- A** “SOS” button *
- B** Indicator lights
- C** Microphone
- D** Speaker

*: This button is intended for communication with the eCall system operator. Other SOS buttons available in other systems of a motor vehicle do not relate to the device and are not intended for

communication with the eCall system operator.

Emergency Notification Services

■ **Automatic Emergency Calls**

If any airbag deploys, the system is designed to automatically call the eCall control center.* The answering operator receives the vehicle’s location, the time of the incident and the vehicle VIN, and attempts to speak with the vehicle occupants to assess the situation. If the occupants are unable to communicate, the operator automatically treats the call as an emergency and contacts the nearest emergency services provider (112 system etc.) to describe the situation and request that assistance be sent to the location.

*: In some cases, the call cannot be made. (→P.65)

■ **Manual Emergency Calls**

In the event of an emergency, press the “SOS” button to call the eCall control center.* The answering operator will determine your vehicle’s location, assess the situation, and dispatch the necessary assistance required.

Make sure to open the cover before pressing the “SOS” button.

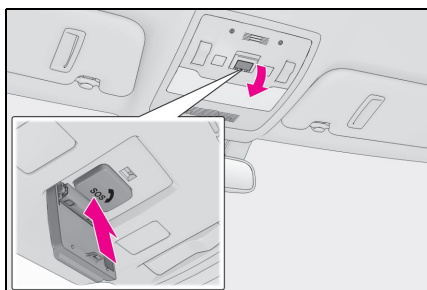

If you accidentally press the “SOS” button, tell the operator that you are not experiencing an emergency.

*: In some cases, the call cannot be made. (→P.65)

Indicator lights

When the engine switch is turned to ON, the red indicator light will illuminate for 10 seconds and then the green indicator light will illuminate, indicating that the system is enabled. The indicator lights indicate the following:

- If the green indicator light illuminates and stays on, the system is enabled.
- If the green indicator light flashes twice per second, an automatic or manual Emergency Call is being made.
- If no indicator lights illuminate, the system is not enabled.
- If the red indicator light illuminates at any time other than immediately after the engine switch is turned to ON, the system may be malfunctioning or the backup battery may be depleted.

- If the red indicator light blinks for approximately 30 seconds during an Emergency Call, the call has been disconnected or the cellular network signal is weak.

The service life of the backup battery does not exceed 3 years.

Free/Open Source Software Information

This product contains Free/Open Source Software (FOSS).

The license information and/or the source code of such FOSS can be found at the following URL.

<https://www.denso.com/global/en/opensource/dcm/toyota/>

⚠ WARNING

■ When the Emergency Call may not be made

- It may not be possible to make Emergency Calls in any of the following situations. In such cases, report to emergency services provider (112 system etc.) by other means such as nearby public phones.
- Even when the vehicle is in the cellular phone service area, it may be difficult to connect to the eCall control center if the reception is poor or the line is busy. In such cases, even though the system attempts to connect to the eCall control center, you may not be able to connect to the eCall control center to make Emergency Calls and contact emergency services.
- When the vehicle is out of the cellular phone service area, the Emergency Calls cannot be made.

⚠ WARNING

- When any related equipment (such as the "SOS" button panel, indicator lights, microphone, speaker, DCM, antenna, or any wires connecting the equipment) is malfunctioning, damaged or broken, the Emergency Call cannot be made.
- During an Emergency Call, the system makes repeated attempts to connect to the eCall control center. However, if it cannot connect to the eCall control center due to poor radio wave reception, the system may not be able to connect to the cellular network and the call may finish without connecting. The red indicator light will blink for approximately 30 seconds to indicate this disconnection.

- If the battery's voltage decreases or there is a disconnection, the system may not be able to connect to the eCall control center.

■ When the Emergency Call system is replaced with a new one

The Emergency Call system should be registered. Contact any authorized Lexus retailer or Lexus authorized repairer, or any reliable repairer.

■ For your safety

- Please drive safely.
The function of this system is to assist you in making the Emergency Call in case of accidents such as traffic accidents or sudden medical emergencies, and it does not protect the driver or passengers in any way. Please drive safely and fasten your seatbelts at all times for your safety.
- In case of an emergency, make lives the top priority.
- If you smell anything burning or other unusual smells, leave the vehicle and evacuate to a safe area immediately.

- If the airbags deploy when the system is operating normally, the system makes emergency call. The system also makes emergency call when the vehicle is struck from the rear or rolls over, even if the airbags do not deploy.

- For safety, do not make the Emergency Call while driving.
Making calls during driving may cause mishandling of the steering wheel, which may lead to unexpected accidents.
Stop the vehicle and confirm the safety of your surroundings before making the Emergency Call.

- When changing fuses, please use the specified fuses. Using other fuses may cause ignition or smoke in the circuit and lead to a fire.

- Using the system while there is smoke or an unusual smell may cause a fire.
Stop using the system immediately and consult any authorized Lexus retailer or Lexus authorized repairer, or any reliable repairer.

⚠ NOTICE**■ To prevent damage**

Do not pour any liquids onto the "SOS" button panel, etc. and do not impact it.

■ If the "SOS" button panel, speaker or microphone malfunctions during an Emergency Call or manual maintenance check

It may not be possible to make Emergency Calls, confirm the system status, or communicate with the eCall control center operator. If any of the above equipment is damaged, please consult any authorized Lexus retailer or Lexus authorized repairer, or any reliable repairer.

System overview of added service

■ Data processing flow

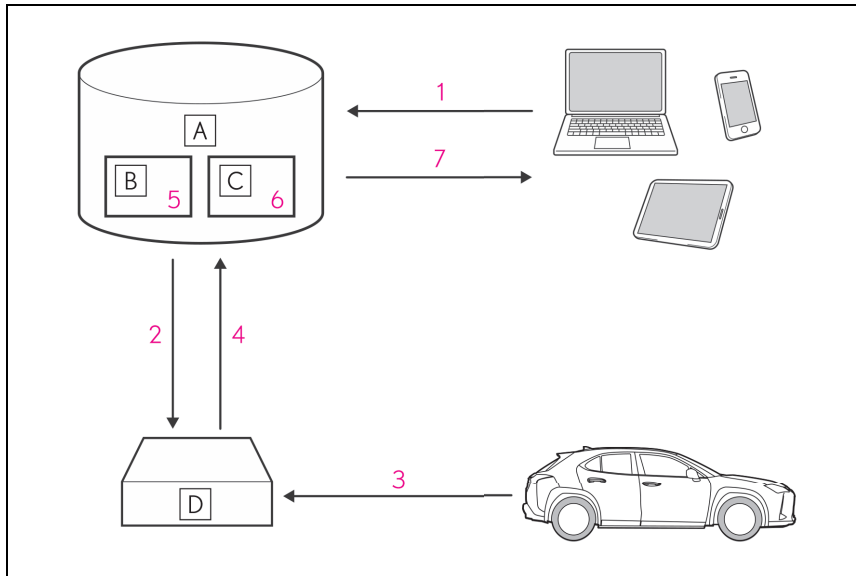

A Server

B Storage

C Processing

D DCM

1 Customer activates service on Lexus Customer portal & accepts terms of services according to GDPR.

2 Server activates the service in the DCM and defines which vehicle data to collect.

3 Defined vehicle data is collected by the DCM.

4 Data is shared with the server.

5 Data is stored in the server.

6 Data is processed in the server for fulfilling the service.

7 Processed data is presented to the customer.

For a list of eligible service please visit the Lexus Customer portal.

Implementing Regulation

Implementing Regulation Annex1 PART3 User Information			Conformity
1. DESCRIPTION OF THE ECALL IN-VEHICLE SYSTEM			
1.1.	Overview of the 112-based eCall in-vehicle system, its operation and functionalities		○
1.2.	The 112-based eCall service is a public service of general interest and is accessible free of charge.		○
1.3.	The 112-based eCall in-vehicle system is activated by default. It is activated automatically by means of in-vehicle sensors in the event of a severe accident. It will also be triggered automatically when the vehicle is equipped with a TPS system which does not function in the event of a severe accident.		○
1.4.	The 112-based eCall in-vehicle system can also be triggered manually, if needed. Instructions for manual activation of the system		○
1.5.	In the event of a critical system failure that would disable the 112-based eCall in-vehicle system, the following warning will be given to the occupants of the vehicle		○
2. INFORMATION ON DATA PROCESSING			

Implementing Regulation Annex1 PART3 User Information		Conformity
2.1.	Any processing of personal data through the 112-based eCall in-vehicle system shall comply with the personal data protection rules provided for in Directives 95/46/EC and 2002/58/EC, and in particular, shall be based on the necessity to protect the vital interests of the individuals in accordance with Article 7(d) of Directive 95/46/EC.	○
2.2.	Processing of such data is strictly limited to the purpose of handling the emergency eCall to the single European emergency number 112.	○
2.3. Types of data and its recipients		
2.3.1.	The 112-based eCall in-vehicle system may collect and process only the following data: Vehicle Identification Number, Vehicle type (passenger vehicle or light commercial vehicle), Vehicle propulsion storage type (gasoline/diesel/CNG/LPG/electric/hydrogen), Vehicle last three locations and direction of travel, Log file of the automatic activation of the system and its timestamp	○
2.3.2.	Recipients of data processed by the 112-based eCall in-vehicle system are the relevant public safety answering points designated by the respective public authorities of the country on which territory they are located, to first receive and handle eCalls to the single European emergency number 112.	○

Implementing Regulation Annex1 PART3 User Information		Conformity
2.4. Arrangements for data processing		
2.4.1.	The 112-based eCall in-vehicle system is designed in such a way as to ensure that the data contained in the system memory is not available outside the system before an eCall is triggered.	○
2.4.2.	The 112-based eCall in-vehicle system is designed in such a way as to ensure that it is not traceable and not subject to any constant tracking in its normal operation status.	○
2.4.3.	The 112-based eCall in-vehicle system is designed in such a way as to ensure that data in the system internal memory is automatically and continuously removed.	○
2.4.3.1.	The vehicle location data is constantly overwritten in the internal memory of the system so as always to keep maximum of the last three up-to-date locations of the vehicle necessary for the normal functioning of the system.	○
2.4.3.2.	The log of activity data in the 112-based eCall in-vehicle system is kept for no longer than necessary for attaining the purpose of handling the emergency eCall and in any case not beyond 13 hours from the moment an emergency eCall was initiated.	○

Implementing Regulation Annex1 PART3 User Information		Conformity
2.5. Modalities for exercising data subject's rights		
2.5.1.	The data subject (the vehicle's owner) has a right of access to data and as appropriate to request the rectification, erasure or blocking of data, concerning him or her, the processing of which does not comply with the provisions of Directive 95/46/EC. Any third parties to whom the data have been disclosed have to be notified of such rectification, erasure or blocking carried out in compliance with this Directive, unless it proves impossible or involves a disproportionate effort.	○
2.5.2.	The data subject has a right to complain to the competent data protection authority if he or she considers that his or her rights have been infringed as a result of the processing of his or her personal data.	○
2.5.3.	Contact service responsible for handling access requests (if any): →P.73	○
3. INFORMATION ON THIRD PARTY SERVICES AND OTHER ADDED VALUE SERVICES (IF FITTED)		

Implementing Regulation Annex1 PART3 User Information		Conformity
3.1.	Description of the operation and the functionalities of the TPS system/added value service	→P.67
3.2.	Any processing of personal data through the TPS system/other added value service shall comply with the personal data protection rules provided for in Directives 95/46/EC and 2002/58/EC.	○
3.2.1.	Legal basis for the use of TPS system and/or added value services and for processing data through them	The European Union General Data Protection Regulation
3.3.	The TPS system and/or other added value services shall process personal data only on the base of the explicit consent of the data subject (the vehicle's owner or owners).	○
3.4.	Modalities for data processing through TPS system and/or other added value services, including any necessary additional information regarding traceability, tracking and processing of personal data	→P.67
3.5.	The owner of a vehicle equipped with a TPS eCall system and/or other added value service in addition to the 112-based eCall in-vehicle system has the right to choose to use the 112-based eCall in-vehicle system rather than the TPS eCall system and the other added value service.	○
3.5.1.	Contact details for handling TPS eCall system deactivation requests	N/A

■ Service responsible for handling access requests

Country	Contact information
Austria	datenschutz@toyota-frey.at
Belgium/Luxembourg	privacy@toyota.be
Croatia	dpcp@toyota.hr
Czech Republic/Hungary/Slovakia	adatvedelem@toyota-ce.com
Denmark	toyota@toyota.dk og
Estonia	privacy@lexus.ee
Finland	tietosuoja@toyota.fi
France	delegue.protectiondonnees@toyota-europe.com
Germany	Toyota.Datenschutz@toyota.de
Great Britain	privacy@tgb.toyota.co.uk
Greece	customer@toyota.gr
Iceland	personuvernd@toyota.is
Ireland	customerservice@toyota.ie
Italy	tmi.dpo@toyota-europe.com
Netherlands	www.toyota.nl/klantenservice
Norway	personvern@toyota.no
Poland	klient@toyota.pl
Portugal	gestaodadospessoais@toyotacaetano.pt
Romania	relatii.clienti@toyota.ro
Slovenia	dpcp@toyota.si
Spain	clientes@lexusauto.es / dpo@lexusauto.es
Sweden	integritet@lexus.se
Switzerland	info@toyota.ch

■ Certification for eCall

<p>Manufacturer: DENSO CORPORATION Address: 1-1, Showa-cho, Kariya-shi, Aichi-ken, 448-8661, Japan Model: OGEU47 Operation frequency: GSM900 Tx: 880-915MHz, Rx: 925-960 MHz GSM1800 Tx: 1710-1785MHz, Rx: 1805-1880 MHz W-CDMA Band1 Tx: 1920-1980MHz, Rx: 2110-2170 MHz W-CDMA Band8 Tx: 880-915MHz, Rx: 925-960 MHz GPS 1575.42MHz GALILEO 1575.42MHz EGNOS 1575.42MHz Maximum output power: GSM900 2W GSM1800 1W W-CDMA Band1 0.25W W-CDMA Band8 0.25W</p>	
<p>Hereby, DENSO CORPORATION declares that the radio equipment type is in compliance with Directive 2014/53/EU. The full text of the EU declaration of conformity is available at the following internet address: https://www.denso.com/global/en/contact-us/doc/</p>	01
<p>DENSO CORPORATION vakuuttaa, että radiolaitetyyppi on direktiivin 2014/53/EU mukainen. EU-vaatimustenmukaisuusvakuutuksen täysimittainen teksti on saatavilla seuraavassa internetosoitteessa: https://www.denso.com/global/en/contact-us/doc/</p>	02
<p>Hierbij verklaar ik, DENSO CORPORATION, dat het type radioapparatuur conform is met Richtlijn 2014/53/EU. De volledige tekst van de EU-conformiteitsverklaring kan worden geraadpleegd op het volgende internetadres: https://www.denso.com/global/en/contact-us/doc/</p>	03

Le soussigné, DENSO CORPORATION, déclare que l'équipement radioélectrique du type est conforme à la directive 2014/53/UE. Le texte complet de la déclaration UE de conformité est disponible à l'adresse internet suivante: https://www.denso.com/global/en/contact-us/doc/	04
Härmed försäkrar DENSO CORPORATION att denna typ av radioutrustning överensstämmer med direktiv 2014/53/EU. Den fullständiga texten till EU-försäkran om överensstämmelse finns på följande webbadress: https://www.denso.com/global/en/contact-us/doc/	05
Hermed erklærer DENSO CORPORATION, at radioudstyrstypen er i overensstemmelse med direktiv 2014/53/EU. EU-overensstemmelseserklæringens fulde tekst kan findes på følgende internetadresse: https://www.denso.com/global/en/contact-us/doc/	06
Hiermit erklährt DENSO CORPORATION, dass der Funkanlagentyp der Richtlinie 2014/53/EU entspricht. Der vollständige Text der EU-Konformitätserklärung ist unter der folgenden Internetadresse verfügbar: https://www.denso.com/global/en/contact-us/doc/	07
Με την παρούσα ο/η DENSO CORPORATION, δηλώνει ότι ο ραδιοεξοπλισμός πληροί την οδηγία 2014/53/ΕΕ. Το πλήρες κείμενο της δήλωσης συμμόρφωσης ΕΕ διατίθεται στην ακόλουθη ιστοσελίδα στο διαδίκτυο: https://www.denso.com/global/en/contact-us/doc/	08
Il fabbricante, DENSO CORPORATION, dichiara che il tipo di apparecchiatura radio è conforme alla direttiva 2014/53/UE. Il testo completo della dichiarazione di conformità UE è disponibile al seguente indirizzo Internet: https://www.denso.com/global/en/contact-us/doc/	09

<p>Por la presente, DENSO CORPORATION declara que el tipo de equipo radioeléctrico es conforme con la Directiva 2014/53/UE. El texto completo de la declaración UE de conformidad está disponible en la dirección Internet siguiente: https://www.denso.com/global/en/contact-us/doc/</p>	10
<p>O(a) abaixo assinado(a) DENSO CORPORATION declara que o presente tipo de equipamento de rádio está em conformidade com a Diretiva 2014/53/UE. O texto integral da declaração de conformidade está disponível no seguinte endereço de Internet: https://www.denso.com/global/en/contact-us/doc/</p>	11
<p>B'dan, DENSO CORPORATION, niddikjara li dan it-tip ta' tagħmir tar-radju huwa konformi mad-Direttiva 2014/53/UE. It-test kollu tad-dikjarazzjoni ta' konformità tal-UE huwa disponibbli f'dan l-indirizz tal-Internet li ġej: https://www.denso.com/global/en/contact-us/doc/</p>	12
<p>Käesolevaga deklareerib DENSO CORPORATION, et käesolev raadioseadme tüüp vastab direktiivi 2014/53/EL nõuetele. ELi vastavusdeklaratsiooni täielik tekst on kättesaadav järgmisel internetiaadressil: https://www.denso.com/global/en/contact-us/doc/</p>	13
<p>DENSO CORPORATION igazolja, hogy a típusú rádióberendezés megfelel a 2014/53/EU irányelvnek. Az EU-megfelelőségi nyilatkozat teljes szövege elérhető a következő internetes címen: https://www.denso.com/global/en/contact-us/doc/</p>	14
<p>DENSO CORPORATION týmto vyhlasuje, že rádiové zariadenie typu je v súlade so smernicou 2014/53/EÚ. Úplné EÚ vyhlásenie o zhode je k dispozícii na tejto internetovej adrese: https://www.denso.com/global/en/contact-us/doc/</p>	15

<p>Tímto DENSO CORPORATION prohlašuje, že typ rádiového zařízení je v souladu se směrnicí 2014/53/EU. Úplné znění EU prohlášení o shodě je k dispozici na této internetové adrese: https://www.denso.com/global/en/contact-us/doc/</p>	16
<p>DENSO CORPORATION potvrzuje, da je tip radijske opreme skladen z Direktivo 2014/53/EU. Celotno besedilo izjave EU o skladnosti je na voljo na naslednjem spletnem naslovu: https://www.denso.com/global/en/contact-us/doc/</p>	17
<p>Aš, DENSO CORPORATION, patvirtinu, kad radijo įrenginių tipas atitinka Direktyvą 2014/53/ES. Visas ES atitikties deklaracijos tekstas prieinamas šiuo interneto adresu: https://www.denso.com/global/en/contact-us/doc/</p>	18
<p>Ar šo DENSO CORPORATION deklarē, ka radioiekārta atbilst Direktīvai 2014/53/ES. Pilns ES atbilstības deklarācijas teksts ir pieejams šādā interneta vietnē: https://www.denso.com/global/en/contact-us/doc/</p>	19
<p>DENSO CORPORATION niniejszym oświadcza, że typ urządzenia radiowego jest zgodny z dyrektywą 2014/53/UE. Pełny tekst deklaracji zgodności UE jest dostępny pod następującym adresem internetowym: https://www.denso.com/global/en/contact-us/doc/</p>	20
<p>Hér með lýsir DENSO CORPORATION yfir því að er í samræmi við grunnkröfur og aðrar kröfur, sem gerðar eru í tilskipun 2014/53/EU. Samræmisýfirlýsing er einhig aðgengileg á eftirfarandi vefslóð: https://www.denso.com/global/en/contact-us/doc/</p>	21

DENSO CORPORATION erklærer at er i overensstemmelse med direktiv 2014/53/EU. Samsvarserklæringen i fulltekst er tilgjengelig på følgende internettsadresse: https://www.denso.com/global/en/contact-us/doc/	22
С настоящото DENSO CORPORATION декларира, че този тип радиосъоръжение е в съответствие с Директива 2014/53/ЕС. Цялостният текст на ЕС декларацията за съответствие може да се намери на следния интернет адрес: https://www.denso.com/global/en/contact-us/doc/	23
Prin prezenta, DENSO CORPORATION declară că tipul de echipamente radio este în conformitate cu Directiva 2014/53/UE. Textul integral al declarației UE de conformitate este disponibil la următoarea adresă internet: https://www.denso.com/global/en/contact-us/doc/	24
DENSO CORPORATION ovime izjavljuje da je radijska oprema tipa u skladu s Direktivom 2014/53/EU. Cjeloviti tekst EU izjave o sukladnosti dostupan je na sljedećoj internetskoj adresi: https://www.denso.com/global/en/contact-us/doc/	25
Овиме, DENSO CORPORATION изјављује да је радио опрема тип усаглашена са Директивом 2014/53/EU. Цео текст ЕУ декларације о усаглашености доступам је на следећој интернет адреси: https://www.denso.com/global/en/contact-us/doc/	26
İşbu belge; DENSO CORPORATION telsiz ekipmanı tipinin 2014/53/AB sayılı Direktif'e uygun olduğunu beyan eder. AB uygunluk beyanının tam metni aşağıdaki internet adresinde mevcuttur: https://www.denso.com/global/en/contact-us/doc/	27

Ovim, DENSO CORPORATION, izjavljuje da ovaj OGEU47 je usklađen sa bitnim zahtjevima i drugim relevantnim odredbama Direktive 1999/5/EC.	28
Nepermjet kesaj, DENSO CORPORATION, deklaruj qe ky OGEU47 eshte ne pajtim me kerkesat thelbesore dhe dispozitat e tjera perkatese te Direktives 1999/5/EC.	29
 The latest "DECLARATION of CONFORMITY" (DoC) is available at the following address: https://www.denso.com/global/en/contact-us/doc/	30

ERA-GLONASS/EVAK^{*1, 2}

^{*1}: If equipped

^{*2}: Operates within the ERA-GLONASS/EVAK coverage. The system name differs depending on the country.

The Emergency Call system is a device installed on a vehicle to determine its location and movement direction (using GLONASS [Global Navigation Satellite System] and GPS [Global Positioning System] signals), and ensure the generation and transmission of vehicle information (in a nonadjustable form) in case of traffic accidents or other incidents on motor roads in the Russian Federation/Kazakhstan. In addition, it ensures two-way voice communication between the vehicle and an ERA-GLONASS/EVAK system operator through cellular networks (GSM).

Automatic Emergency Calls (via Automatic Collision Notification) and manual Emergency Calls (by pressing the "SOS" button) can be made to the ERA-GLONASS/EVAK control center. This service is mandatory according to the technical regulations of the Customs Union.

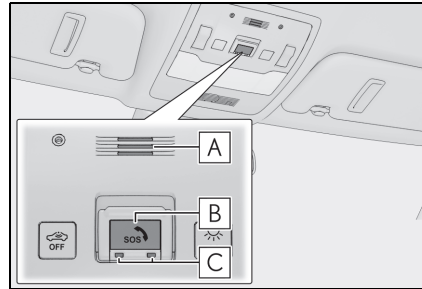
System components

A Microphone

B "SOS" button *

C Indicator lights

*: This button is intended for communication with the ERA-GLONASS/EVAK system operator. Other SOS buttons available in other systems of a motor vehicle do not relate to the device and are not intended for communication with the ERA-GLONASS/EVAK system operator.

Emergency Notification Services**■ Automatic Emergency Calls**

If any airbag deploys, the system is designed to automatically call the ERA-GLONASS/EVAK control center.*

The answering operator receives the vehicle's location, the time of the incident and the vehicle VIN, and attempts to speak with the vehicle occupants to assess the situation. If the occupants are unable to communicate, the operator automatically treats the call as an emergency and contacts the nearest

emergency services provider (112 system etc.) to describe the situation and request that assistance be sent to the location.

*: In some cases, the call cannot be made. (→P.81)

■ Manual Emergency Calls

In the event of an emergency, press the "SOS" button to call the ERA-

GLONASS/EVAK control center.*

The answering operator will determine your vehicle's location, assess the situation, and dispatch the necessary assistance required.

If you accidentally press the "SOS" button, tell the operator that you are not experiencing an emergency.

*: In some cases, the call cannot be made. (→P.81)

Indicator lights

When the engine switch is turned to ON, the red indicator light will illuminate for 10 seconds and then the green indicator light will illuminate, indicating that the system is enabled. The indicator lights indicate the following:

- If the green indicator light illuminates and stays on, the system is enabled.
- If the green indicator light flashes twice per second, an automatic or manual Emergency Call is being made.
- If no indicator lights illuminate, the system is not enabled.

- If the red indicator light illuminates at any time other than immediately after the engine switch is turned to ON, the system may be malfunctioning or the backup battery may be depleted.

- If the red indicator light blinks for approximately 30 seconds during an Emergency Call, the call has been disconnected or the cellular network signal is weak.

The service life of the backup battery does not exceed 3 years.

Device test mode

A test mode is provided for to check the performance of the Emergency Call system. To test the device, contact any authorized Lexus retailer or Lexus authorized repairer, or any reliable repairer.

WARNING

■ When the Emergency Call may not be made

- It may not be possible to make Emergency Calls in any of the following situations. In such cases, report to emergency services provider (112 system etc.) by other means such as nearby public phones.

⚠ WARNING

- Even when the vehicle is in the cellular phone service area, it may be difficult to connect to the ERA-GLONASS/EVAK control center if the reception is poor or the line is busy. In such cases, even though the system attempts to connect to the ERA-GLONASS/EVAK control center, you may not be able to connect to the ERA-GLONASS/EVAK control center to make Emergency Calls and contact emergency services.
- When the vehicle is out of the cellular phone service area, the Emergency Calls cannot be made.
- When any related equipment (such as the "SOS" button panel, indicator lights, microphone, speaker, DCM, antenna, or any wires connecting the equipment) is malfunctioning, damaged or broken, the Emergency Call cannot be made.
- During an Emergency Call, the system makes repeated attempts to connect to the ERA-GLONASS/EVAK control center. However, if it cannot connect to the ERA-GLONASS/EVAK control center due to poor radio wave reception, the system may not be able to connect to the cellular network and the call may finish without connecting. The red indicator light will blink for approximately 30 seconds to indicate this disconnection.
- This device may not function if a shock is applied to it.
- If the battery's voltage decreases or there is a disconnection, the system may not be able to connect to the ERA-GLONASS/EVAK control center.

■ When the Emergency Call system is replaced with a new one

The Emergency Call system should be registered. Contact any authorized Lexus retailer or Lexus authorized repairer, or any reliable repairer.

■ For your safety

- Please drive safely.
The function of this system is to assist you in making the Emergency Call in case of accidents such as traffic accidents or sudden medical emergencies, and it does not protect the driver or passengers in any way. Please drive safely and fasten your seatbelts at all times for your safety.
- In case of an emergency, make lives the top priority.
- If you smell anything burning or other unusual smells, leave the vehicle and evacuate to a safe area immediately.
- Since the system detects shocks, the automatic reporting may not always occur synchronized with the operation of the airbag system. (If the vehicle is struck from behind, etc.)
- For safety, do not make the Emergency Call while driving.
Making calls during driving may cause mishandling of the steering wheel, which may lead to unexpected accidents.
Stop the vehicle and confirm the safety of your surroundings before making the Emergency Call.
- When changing fuses, please use the specified fuses. Using other fuses may cause ignition or smoke in the circuit and lead to a fire.
- Using the system while there is smoke or an unusual smell may cause a fire.
Stop using the system immediately and consult any authorized Lexus retailer or Lexus authorized repairer, or any reliable repairer.

**NOTICE****■ To prevent damage**

Do not pour any liquids onto the “SOS” button panel, etc. and do not impact it.

■ If the “SOS” button panel, speaker or microphone malfunctions during an Emergency Call or manual maintenance check

It may not be possible to make Emergency Calls, confirm the system status, or communicate with the ERA-GLONASS/EVAK control center operator. If any of the above equipment is damaged, please consult any authorized Lexus retailer or Lexus authorized repairer, or any reliable repairer.

Engine immobilizer system

The vehicle's keys have built-in transponder chips that prevent the engine from starting if a key has not been previously registered in the vehicle's on-board computer.

Never leave the keys inside the vehicle when you leave the vehicle.

This system is designed to help prevent vehicle theft but does not guarantee absolute security against all vehicle thefts.

Operating the system



The security indicator flashes after the engine switch has been turned off to indicate that the system is operating.

The indicator stops flashing after the engine switch has been turned to ACC or ON to indicate that the system has been canceled.

System maintenance

The vehicle has a maintenance-free type engine immobilizer system.

Conditions that may cause the system to malfunction

- If the grip portion of the key is in contact with a metallic object
- If the key is in close proximity to or touching a key registered to the security system (key with a built-in transponder chip) of another vehicle

■ Certification for the engine immobilizer system

Hereby, TOYOTA MOTOR CORPORATION declares that the radio equipment type TMIMB-3 is in compliance with Directive 2014/53/EU.

The full text of the EU declaration of conformity is available at the following internet address:

<http://my.lexus.eu>

Frequency band: 119 - 135 kHz

Maximum radio-frequency power: 55dB μ A/m @10m

TOYOTA MOTOR CORPORATION vakuuttaa, että radiolaitetyyppi TMIMB-3 on direktiivin 2014/53/EU mukainen.

EU-vaatimustenmukaisuusvakuutuksen täysimittainen teksti on saatavilla seuraavassa internetosoitteessa:

<http://my.lexus.eu>

Radiotaajuus: 119 - 135 kHz

suurin mahdollinen lähetysteho: 55dB μ A/m @10m

Hierbij verklaar ik, TOYOTA MOTOR CORPORATION, dat het type radioapparatuur TMIMB-3 conform is met Richtlijn 2014/53/EU.

De volledige tekst van de EU-conformiteitsverklaring kan worden geraadpleegd op het volgende internetadres:

<http://my.lexus.eu>

Frequentieband: 119 - 135 kHz

Maximaal radiofrequentievermogen: 55dB μ A/m @10m

Le soussigné, TOYOTA MOTOR CORPORATION, déclare que l'équipement radioélectrique du type TMIMB-3 est conforme à la directive 2014/53/UE.

Le texte complet de la déclaration UE de conformité est disponible à l'adresse internet suivante:

<http://my.lexus.eu>

Bande de fréquences: 119 - 135 kHz

Puissance de radiofréquence maximale: 55dB μ A/m @10m

Härmed försäkrar TOYOTA MOTOR CORPORATION att denna typ av radioutrustning TMIMB-3 överensstämmer med direktiv 2014/53/EU.

Den fullständiga texten till EU-försäkran om överensstämmelse finns på följande webbadress:

<http://my.lexus.eu>

Frekvensband: 119 - 135 kHz

Maximal radiofrekvensseffekt: 55dB μ A/m @10m

Hermed erklærer TOYOTA MOTOR CORPORATION, at radioudstyrstypen TMIMB-3 er i overensstemmelse med direktiv 2014/53/EU.

EU-overensstemmelseserklæringens fulde tekst kan findes på følgende internetadresse:

<http://my.lexus.eu>

Frekvensbånd: 119 - 135 kHz

Maksimal radiofrekvensseffekt: 55dB μ A/m @10m

Hiermit erklärt TOYOTA MOTOR CORPORATION, dass der Funkanlagentyp TMIMB-3 der Richtlinie 2014/53/EU entspricht.

Der vollständige Text der EU-Konformitätserklärung ist unter der folgenden Internetadresse verfügbar:

<http://my.lexus.eu>

Frequenzband: 119 - 135 kHz

Abgestrahlte maximale Sendeleistung: 55dBμA/m @10m

Με την παρούσα ο/η TOYOTA MOTOR CORPORATION, δηλώνει ότι ο ραδιοεξοπλισμός TMIMB-3 πληροί την οδηγία 2014/53/ΕΕ.

Το πλήρες κείμενο της δήλωσης συμμόρφωσης ΕΕ διατίθεται στην ακόλουθη ιστοσελίδα στο διαδίκτυο:

<http://my.lexus.eu>

Ζώνη συχνότητων: 119 - 135 kHz

Μέγιστη ισχύς ραδιοσυχνότητας: 55dBμA/m @10m

Il fabbricante, TOYOTA MOTOR CORPORATION, dichiara che il tipo di apparecchiatura radio TMIMB-3 è conforme alla direttiva 2014/53/UE.

Il testo completo della dichiarazione di conformità UE è disponibile al seguente indirizzo Internet:

<http://my.lexus.eu>

Banda di frequenza: 119 - 135 kHz

Potenza massima radiofrequenza: 55dBμA/m @10m

Por la presente, TOYOTA MOTOR CORPORATION declara que el tipo de equipo radioeléctrico TMIMB-3 es conforme con la Directiva 2014/53/UE.

El texto completo de la declaración UE de conformidad está disponible en la dirección Internet siguiente:

<http://my.lexus.eu>

Banda de frecuencia: 119 - 135 kHz

Potencia máxima de radiofrecuencia: 55dB μ A/m @10m

O(a) abaixo assinado(a) TOYOTA MOTOR CORPORATION declara que o presente tipo de equipamento de rádio TMIMB-3 está em conformidade com a Diretiva 2014/53/UE.

O texto integral da declaração de conformidade está disponível no seguinte endereço de Internet:

<http://my.lexus.eu>

Banda de frequência: 119 - 135 kHz

Potência máxima de radiofrequências: 55dB μ A/m @10m

B'dan, TOYOTA MOTOR CORPORATION, niddikjara li dan it-tip ta' tagħmir tar-radju TMIMB-3 huwa konformi mad-Direttiva 2014/53/UE.

It-test kollu tad-dikjarazzjoni ta' konformità tal-UE huwa disponibbli f'dan l-indirizz tal-Internet li ġej:

<http://my.lexus.eu>

Tíðnisvið: 119 - 135 kHz

Hámarks útvarpsbylgjutíðni: 55dB μ A/m @10m

Käesolevaga deklareerib TOYOTA MOTOR CORPORATION, et käesolev raadioseadme tüüp TMIMB-3 vastab direktiivi 2014/53/EL nõuetele.

ELi vastavusdeklaratsiooni täielik tekst on kättesaadav järgmisel internetiaadressil:

<http://my.lexus.eu>

Sagedusriba: 119 - 135 kHz

Maksimaalne saatevõimsus: 55dB μ A/m @10m

TOYOTA MOTOR CORPORATION igazolja, hogy a TMIMB-3 típusú rádióberendezés megfelel a 2014/53/EU irányelvnek.

Az EU-megfelelőségi nyilatkozat teljes szövege elérhető a következő internetes címen:

<http://my.lexus.eu>

Frekvenciasáv: 119 - 135 kHz

Maximális jelerősség: 55dB μ A/m @10m

TOYOTA MOTOR CORPORATION týmto vyhlasuje, že rádiové zariadenie typu TMIMB-3 je v súlade so smernicou 2014/53/EÚ.

Úplné EÚ vyhlásenie o zhode je k dispozícii na tejto internetovej adrese:

<http://my.lexus.eu>

Frekvenčné pásmo: 119 - 135 kHz

Maximálny rádiový výkon: 55dB μ A/m @10m

Tímto TOYOTA MOTOR CORPORATION prohlašuje, že typ rádiového zařízení TMIMB-3 je v souladu se směrnicí 2014/53/EU.

Úplné znění EU prohlášení o shodě je k dispozici na této internetové adrese:

<http://my.lexus.eu>

Kmitočtové pásmo: 119 - 135 kHz

Maximální radiofrekvenční výkon: 55dB μ A/m @10m

TOYOTA MOTOR CORPORATION potvrzuje, da je tip radijske opreme TMIMB-3 skladen z Direktivo 2014/53/EU.

Celotno besedilo izjave EU o skladnosti je na voljo na naslednjem spletnem naslovu:

<http://my.lexus.eu>

Frekvenčni pas: 119 - 135 kHz

Največja moč radijske frekvence: 55dB μ A/m @10m

Aš, TOYOTA MOTOR CORPORATION, patvirtinu, kad radijo įrenginių tipas TMIMB-3 atitinka Direktyvą 2014/53/ES.

Visas ES atitikties deklaracijos tekstas prieinamas šiuo interneto adresu:

<http://my.lexus.eu>

Dažnių juosta: 119 - 135 kHz

Didžiausia radijo dažnių galia: 55dB μ A/m @10m

Ar šo TOYOTA MOTOR CORPORATION deklarē, ka radioiekārta TMIMB-3 atbilst Direktīvai 2014/53/ES.

Pilns ES atbilstības deklarācijas teksts ir pieejams šādā interneta vietnē:

<http://my.lexus.eu>

Frekvenču josla: 119 - 135 kHz

Maksimālā radiofrekvenču jauda: 55dBμA/m @10m

TOYOTA MOTOR CORPORATION niniešzym oświadcza, że typ urządzenia radiowego TMIMB-3 jest zgodny z dyrektywą 2014/53/UE.

Pełny tekst deklaracji zgodności UE jest dostępny pod następującym adresem internetowym:

<http://my.lexus.eu>

Zakres częstotliwości: 119 - 135 kHz

Maksymalna moc częstotliwości radiowej: 55dBμA/m @10m

TOYOTA MOTOR CORPORATION lýsir því hér með yfir að fjarskiptatækið af gerð TMIMB-3 er í samræmi við tilskipun 2014/53/EU.

Öll ESB-samræmisýfirlýsingin er tiltæk á eftirfarandi vefslóð:

<http://my.lexus.eu>

Tíðnisvið: 119 - 135 kHz

Hámarks úthvarpsbylgjutíðni: 55dBμA/m @10m

TOYOTA MOTOR CORPORATION erklærer herved at radioutstyrtypen TMIMB-3 er i samsvar med direktivet 2014/53/EU.

Hele teksten av EU-samsvarserklæringen kan leses på det følgende nettstedet:

<http://my.lexus.eu>

Frekvensbånd: 119 - 135 kHz

Maksimal radiofrekvensseffekt: 55dB μ A/m @10m

С настоящото TOYOTA MOTOR CORPORATION декларира, че този тип радиосъоръжение TMIMB-3 е в съответствие с Директива 2014/53/ЕС.

Цялостният текст на ЕС декларацията за съответствие може да се намери на следния интернет адрес:

<http://my.lexus.eu>

Радиочестотна лента: 119 - 135 kHz

Максимална радиочестотна мощност: 55dB μ A/m @10m

Prin prezenta, TOYOTA MOTOR CORPORATION declară că tipul de echipamente radio TMIMB-3 este în conformitate cu Directiva 2014/53/UE.

Textul integral al declarației UE de conformitate este disponibil la următoarea adresă internet:

<http://my.lexus.eu>

Banda de frecvență: 119 - 135 kHz

Puterea maximă de radiofrecvență: 55dB μ A/m @10m

Ovime TOYOTA MOTOR CORPORATION potvrđuje da je radio-oprema tipa TMIMB-3 u skladu sa Direktivom 2014/53/EU.

Potpuni tekst EU deklaracije o usaglašenosti dostupan je na slijedećoj internet adresi:

<http://my.lexus.eu>

Frekvencijski opseg: 119 - 135 kHz

Maksimalna radio-frekvencijska snaga: 55dB μ A/m @10m

Me anë të këtij dokumenti, TOYOTA MOTOR CORPORATION deklararon se tipi i radiopajisjes TMIMB-3 është në përputhje me Direktivën 2014/53/EU.

Teksti i plotë i deklaratës së konformitetit të Bashkimit Evropian është i disponueshëm në adresën e mëposhtme të internetit:

<http://my.lexus.eu>

Brezi i frekuencës: 119 - 135 kHz

Fuqia maksimale e radiofrekuencës: 55dB μ A/m @10m

TOYOTA MOTOR CORPORATION ovime izjavljuje da je radijska oprema tipa TMIMB-3 u skladu s Direktivom 2014/53/EU.

Cjeloviti tekst EU izjave o sukladnosti dostupan je na sljedećoj internetskoj adresi:

<http://my.lexus.eu>

Frekvencijski pojas: 119 - 135 kHz

Maksimalna RF snaga: 55dB μ A/m @10m

Ovim TOYOTA MOTOR CORPORATION potvrđuje da je radio-oprema tipa TMIMB-3 u skladu sa Direktivom 2014/53/EU.

Potpuni tekst EU deklaracije o usaglašenosti dostupan je na sledećoj internet adresi:

<http://my.lexus.eu>

Frekventni opseg: 119 - 135 kHz

Maksimalna radio-frekventna snaga: 55dB μ A/m @10m

TOYOTA MOTOR CORPORATION, işbu belgeyle telsiz cihazı türünün TMIMB-3 2014/53/EU nolu Direktif ile uyumlu olduğunu beyan etmektedir.

AB uygunluk beyanının tam metnine aşağıdaki internet adresinden ulaşabilirsiniz:

<http://my.lexus.eu>

Frekans bandı: 119 - 135 kHz

Maksimum radyo frekans gücü: 55dB μ A/m @10m

TOYOTA

TOYOTA MOTOR CORPORATION

1, TOYOTA-CHO, TOYOTA, AICHI, 471-8571, JAPAN TEL: +81-565-28-2121

EU Declaration of Conformity



1. Radio equipment (Product / Type):
Immobilizer / TMIMB-3
 2. Name and address of the manufacturer:
TOYOTA MOTOR CORPORATION
1, Toyota -cho, Toyota, Aichi, 471-8572, Japan
 3. This declaration of conformity is issued under the sole responsibility of the manufacturer.
 4. Object of the declaration:
TMIMB-3
 5. The object of the declaration described above is in conformity with the relevant Union harmonisation legislation:
Directive 2014/53/EU
 6. References to the relevant harmonised standards used or references to the other technical specifications in relation to which conformity is declared:

(Health & safety requirements)	EN 60950-1:2006 / A11:2009
(EMC requirements)	EN 301 489-1 V1.8.1 & EN 301 489-3 V1.4.1
(Effective uses of radio spectrum)	EN 300 330 V2.1.1
 7. The notified body:
Not Applicable
 8. Accessories and components, including software, which allow the radio equipment to operate as intended and covered by the EU declaration of conformity:
Not Applicable
 9. Additional information:
None
- Place and date of issue Japan, April 5, 2017
- Signature Tomoo Kakegawa
- Function Tomoo Kakegawa
General Manager

1

For safety and security

**NOTICE**

- **To ensure the system operates correctly**

Do not modify or remove the system. If modified or removed, the proper operation of the system cannot be guaranteed.

Double locking system

Unauthorized access to the vehicle is prevented by disabling the door unlocking function from both the interior and exterior of the vehicle.

Vehicles employing this system have labels on the side window of both front doors.

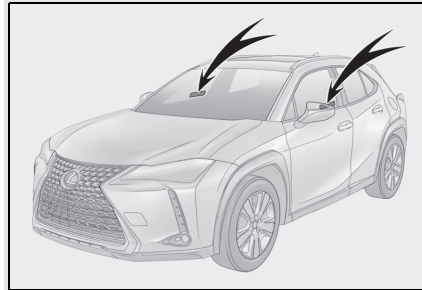
**Setting/canceling the double locking system**

- **Setting**

Turn the engine switch off, have all the passengers exit the vehicle and ensure that all the doors are closed.

Using the entry function:

Touch the sensor area on the outside door handle twice within 5 seconds.

Using the wireless remote control:

Press  twice within 5 seconds.

- **Canceling**

Using the entry function: Hold the outside door handle.

Using the wireless remote control:

Press  .

**WARNING****■ Double locking system precaution**

Never activate the double locking system when there are people in the vehicle, because all the doors cannot be opened from inside the vehicle.

Alarm*

*: If equipped

The alarm uses light and sound to give an alert when an intrusion is detected.

The alarm is triggered in the following situations when the alarm is set:

- A locked door is unlocked or opened in any way other than using the entry function (if equipped) or wireless remote control. (The doors will lock again automatically.)
- The hood is opened.
- The intrusion sensor detects something moving inside the vehicle. (An intruder gets in the vehicle.)
- Vehicles with tilt sensor: The tilt sensor detects a change of vehicle inclination.
- Vehicles with glass breakage sensor: Any of the windows are broken.

Setting/canceling/stopping the alarm system**■ Items to check before locking the vehicle**

To prevent unexpected triggering of the alarm and vehicle theft, make sure of the following.

- Nobody is in the vehicle.

- The windows and moon roof (if equipped) are closed before the alarm is set.
- No valuables or other personal items are left in the vehicle.

■ Setting

Close the doors and hood, and lock all the doors using the entry function (if equipped) or wireless remote control. The system will be set automatically after 30 seconds.

The security indicator changes from being on to flashing when the system is set.



■ Canceling or stopping

Do one of the following to deactivate or stop the alarm.

- Unlock the doors using the entry function (if equipped) or wireless remote control.
- Start the engine. (The alarm will be deactivated or stopped after a few seconds.)

■ System maintenance

The vehicle has a maintenance-free type alarm system.

■ Triggering of the alarm

The alarm may be triggered in the following situations:

(Stopping the alarm deactivates the alarm system.)

- The doors are unlocked using the mechanical key.

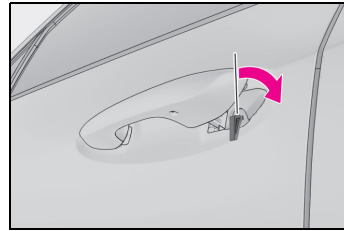

- A person inside the vehicle opens a door or hood, or unlocks the vehicle using an inside lock button.



- The battery is recharged or replaced when the vehicle is locked. (→P.483)

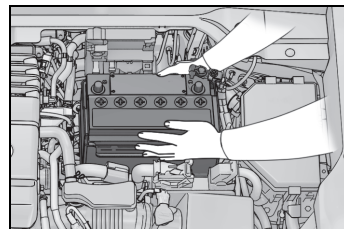

■ Alarm-operated door lock

In the following cases, depending on the situation, the door may automatically lock to prevent improper entry into the vehicle:

- When a person remaining in the vehicle unlocks the door and the alarm is activated.
- While the alarm is activated, a person remaining in the vehicle unlocks the door.
- When recharging or replacing the battery.

■ Customization

The alarm can be set to deactivate when the mechanical key is used to unlock.
(Customizable features: →P.502)



NOTICE

■ To ensure the system operates correctly

Do not modify or remove the system. If modified or removed, the proper operation of the system cannot be guaranteed.

Intrusion sensor (if equipped) and tilt sensor (if equipped)

■ The intrusion sensor and tilt sensor detection

- The intrusion sensor detects intruders or movement in the vehicle.
- The tilt sensor detects changes in vehicle inclination, such as when the vehicle is towed away.

This system is designed to deter and prevent vehicle theft but does not guarantee absolute security against all intrusions.

■ Setting the intrusion sensor and tilt sensor

The intrusion sensor and tilt sensor will be set automatically when the alarm is set. (→P.98)

■ Canceling the intrusion sensor and tilt sensor

If you are leaving pets or other moving things inside the vehicle, make sure to disable the intrusion sensor and tilt sensor before setting the alarm, as they will respond to movement inside the

vehicle.

- 1 Turn the engine switch off.
- 2 Press the intrusion sensor and tilt sensor cancel switch.

Press the switch again to re-enable the intrusion sensor and tilt sensor.

Each time the intrusion sensor and tilt sensor are canceled/set, a message will be shown on the multi-information display in the instrument cluster.

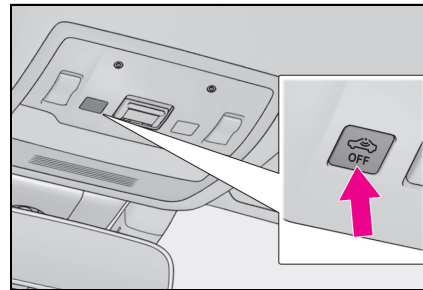

■ Canceling and automatic re-enabling of the intrusion sensor and tilt sensor

- The alarm will still be set even when the intrusion sensor and tilt sensor are canceled.
- After the intrusion sensor and tilt sensor are canceled, pressing the engine switch or unlocking the doors using the entry function (if equipped) or wireless remote control will re-enable the intrusion sensor and tilt sensor.
- The intrusion sensor and tilt sensor will automatically be re-enabled when the alarm system is reactivated.

■ Intrusion sensor detection considerations

The sensor may trigger the alarm in the following situations:

- People or pets are in the vehicle.

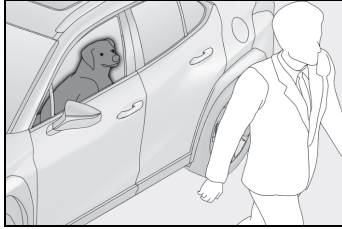

- A window or the moon roof (if equipped) is open.

In this case, the sensor may detect the following:

- Wind or the movement of objects such as leaves and insects inside the vehicle
- Ultrasonic waves emitted from devices such as the intrusion sensors of other vehicles
- The movement of people outside the vehicle

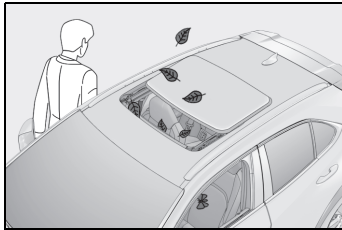

- Unstable items, such as dangling accessories or clothes hanging on the coat hooks, are in the vehicle.

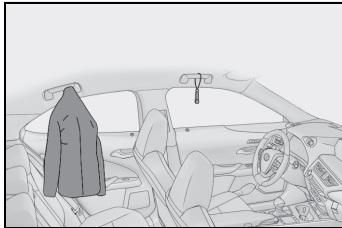

- The vehicle is parked in a place where extreme vibrations or noises occur, such as in a parking garage.

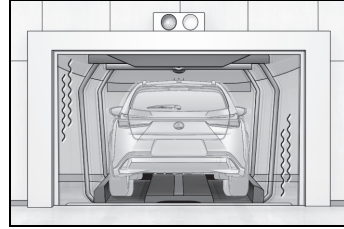

- Ice or snow is removed from the vehicle, causing the vehicle to receive repeated impacts or vibrations.

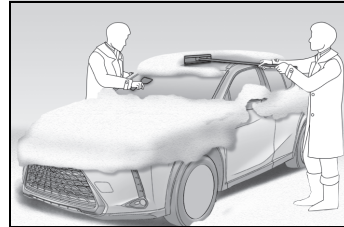

- The vehicle is inside an automatic or high-pressure car wash.
- The vehicle experiences impacts, such as hail, lightning strikes, and other kinds of repeated impacts or vibrations.

■ Tilt sensor detection considerations

The sensor may trigger the alarm in the following situations:

- The vehicle is transported by a ferry, trailer, train, etc.
- The vehicle is parked in a parking garage.
- The vehicle is inside a car wash that moves the vehicle.
- Any of the tires loses air pressure.
- The vehicle is jacked up.
- An earthquake occurs or the road caves in.
- Cargo is loaded onto or unloaded from the roof luggage carrier.

 NOTICE

■ To ensure the intrusion sensor functions correctly

- Do not spray air fresheners or other products directly into the sensor holes.

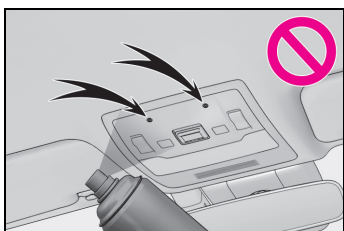

- To ensure that the sensors operate properly, do not touch or cover them.

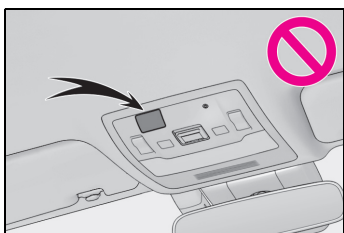

- Installing accessories other than genuine Lexus parts or leaving objects between the driver's seat and front passenger's seat may reduce the detection performance.

Vehicle status information and indicators

2

103

2-1. Instrument cluster

Warning lights and indicators **104**

Gauges and meters (except F SPORT models) **108**

Gauges and meters (F SPORT models)..... **111**

Multi-information display..... **115**

Head-up display **122**

Fuel consumption information **126**

2

Vehicle status information and indicators

Warning lights and indicators

The warning lights and indicators on the instrument cluster, center panel and outside rear view mirrors inform the driver of the status of the vehicle's various systems.

Warning lights and indicators displayed on the instrument cluster

For the purpose of explanation, the following illustrations display all warning lights and indicators illuminated.

► Except F SPORT models



► F SPORT models

























The location of warning lights and indicators may differ depending on the intended destina-

tion of the vehicle and the main meter position.

Warning lights

Warning lights inform the driver of malfunctions in the indicated vehicle's systems.

-  Brake system warning light^{*1}
(red) (→P.444)
-  Charging system warning light^{*2} (→P.444)
-  Low engine oil pressure warning light^{*2} (→P.444)
-  Malfunction indicator lamp^{*1} (→P.445)
-  High coolant temperature warning light^{*2} (→P.445)
-  Tire pressure warning light^{*1} (→P.445)
-  Brake system warning light^{*1}
(yellow) (→P.446)
-  SRS warning light^{*1} (→P.446)
-  ABS warning light^{*1} (→P.446)
-  Electric power steering system warning light^{*1} (→P.446)
(red)
-  Electric power steering system warning light^{*1} (→P.446)
(yellow)
-  Stop & Start cancel indicator^{*1}
(Flashes) (→P.446)
-  Slip indicator^{*1} (→P.447)

-  Parking brake indicator
(Flashes) (→P.447)
-  Brake hold operated indicator^{*1}
(Flashes) (→P.447)
-  Lexus parking assist-sensor OFF indicator (if equipped)
(Flashes) (→P.447)
-  RCTA OFF indicator (if equipped) (→P.448)
(Flashes)
-  PKSB OFF indicator^{*1} (if equipped) (→P.448)
-  Low fuel level warning light (→P.448)
-  Driver's and front passenger's seat belt reminder light (→P.448)
-  Rear passengers' seat belt reminder lights^{*2} (→P.449)
Brake Override System warning light/Drive-Start Control warning light /PKSB warning light^{*2} (→P.449)
-  LTA indicator^{*2} (if equipped) (→P.449)
(orange)
-  PCS warning light^{*1} (if equipped) (→P.450)
(Flashes or illuminates)

^{*1}: These lights come on when the engine switch is turned to ON to indicate that a system check is being performed. They will go off after the engine is on, or after a few seconds. There may be a malfunction in a system if the lights do not come on, or go off. Have the vehicle inspected by any authorized Lexus retailer or

Lexus authorized repairer, or any reliable repairer.

*2: This light illuminates on the multi-information display.









! WARNING

















■ If a safety system warning light does not come on







Should a safety system light such as the ABS and SRS warning light not come on when you start the engine, this could mean that these systems are not available to help protect you in an accident, which could result in death or serious injury. Have the vehicle inspected by any authorized Lexus retailer or Lexus authorized repairer, or any reliable repairer immediately if this occurs.

Indicators

The indicators inform the driver of the operating state of the vehicle's various systems.





-  Turn signal indicator (→P.224)
-  Tail light indicator (→P.231)
-  Headlight high beam indicator (→P.232)
-  AHS indicator*¹ (if equipped) (→P.233)
-  Automatic High Beam indicator*¹ (if equipped) (→P.237)
-  Front fog light indicator (if equipped) (→P.239)
-  Rear fog light indicator (→P.239)
-  PCS warning light*^{1,2} (if equipped) (→P.260)

-  Cruise control indicator*³ (→P.281, 292)
-  Dynamic radar cruise control indicator*³ (if equipped) (→P.281)
-  Cruise control "SET" indicator*³ (→P.281, 292)
-  LTA indicator*³ (if equipped) (→P.273)
-  LTA indicator*³ (if equipped) (→P.273)
-  LTA indicator*^{3,4} (if equipped) (→P.273)
-  BSM outside rear view mirror indicators*^{1,5} (if equipped) (→P.301)
-  BSM indicator (if equipped) (→P.301)
-  Lexus parking assist-sensor OFF indicator*² (if equipped) (→P.314)
-  RCTA OFF indicator*² (if equipped) (→P.320)
-  PKSB OFF indicator*^{1,2} (if equipped) (→P.325)
-  Stop & Start indicator*¹ (→P.294)
-  Stop & Start cancel indicator*^{1,2} (Flashes or illuminates) (→P.299)
-  Slip indicator*^{1,4} (→P.340)
-  VSC OFF indicator*^{1,2} (→P.341)
-  Smart entry & start system indicator*³ (→P.217)



-  Parking brake indicator (→P.225)
-  Brake hold standby indicator ^{*1} (→P.228)
-  Brake hold operated indicator ^{*1} (→P.228)
-  Eco Driving Indicator Light ^{*1,6} (→P.118)
-  Low outside temperature indicator ^{*3,7} (→P.108, 111)
-  Security indicator ^{*8} (→P.84, 98)
-  "PASSENGER AIR BAG" indicator ^{*1,8} (→P.47)

● Drive mode indicators

► Except F SPORT models

-  Custom mode indicator (if equipped) (→P.337)
-  Eco drive mode indicator (→P.337)
-  Sport mode indicator (if equipped) (→P.337)
-  Sport S mode indicator (if equipped) (→P.337)
-  Sport S+ mode indicator (if equipped) (→P.337)

► F SPORT models

-  Custom mode indicator (if equipped) (→P.337)
-  Eco drive mode indicator (→P.337)
-  Sport mode indicator (if equipped) (→P.337)

 Sport S mode indicator (if equipped) (→P.337)

 Sport S+ mode indicator (if equipped) (→P.337)

^{*1}: These lights come on when the engine switch is turned to ON to indicate that a system check is being performed. They will go off after the engine is on, or after a few seconds. There may be a malfunction in a system if the lights do not come on, or go off. Have the vehicle inspected by any authorized Lexus retailer or Lexus authorized repairer, or any reliable repairer.

^{*2}: This light comes on when the system is turned off.

^{*3}: This light illuminates on the multi-information display.

^{*4}: This light flashes to indicate that the system is operating.

^{*5}: This light illuminates on the outside rear view mirrors.

^{*6}: Except F SPORT models: This light illuminates on the multi-information display.

^{*7}: When the outside temperature is approximately 3°C (37°F) or lower, this indicator will flash for approximately 10 seconds, then stay on.

^{*8}: This light illuminates on the center panel.

Gauges and meters (except F SPORT models)

Meter display

■ **Locations of gauges and meters**

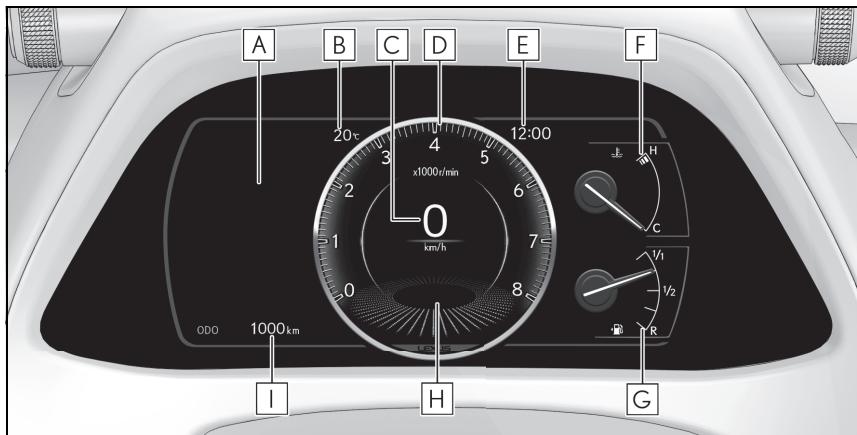

The units of measure may differ depending on the intended destination of the vehicle.

A Multi-information display

Presents the driver with a variety of vehicle data (→P.115)

Displays warning messages if a malfunction occurs (→P.452)

B Outside temperature

Displays the outside temperature within the range of -40°C (-40°F) to 50°C (122°F)

Low outside temperature indicator comes on when the ambient temperature is 3°C (37°F) or lower

C Speedometer

D Tachometer

Displays the engine speed in revolutions per minute

When Sport mode is selected for the driving mode, the periphery of the tachometer will change color and the scale of the tachometer will be emphasized.

E Clock

Time displayed is linked to the analog clock on the center panel. (→P.380)

F Engine coolant temperature gauge

Displays the engine coolant temperature

G Fuel gauge

Displays the quantity of fuel remaining in the tank

H Shift position/shift range (→P.220)

I Odometer and trip meter display (→P.109)

■ Outside temperature display

- In the following situations, the correct outside temperature may not be displayed, or the display may take longer than normal to change:
 - When stopped, or driving at low speeds (less than 20 km/h [12 mph])
 - When the outside temperature has changed suddenly (at the entrance/exit of a garage, tunnel, etc.)
- When "--" or "E" is displayed, the system may be malfunctioning. Take your vehicle to any authorized Lexus retailer or Lexus authorized repairer, or any reliable repairer.

■ Liquid crystal display

→P.116

■ Customization

The gauges and meters can be customized on  of the multi-information display. (→P.502)

WARNING

■ The information display at low temperatures

Allow the interior of the vehicle to warm up before using the liquid crystal information display. At extremely low temperatures, the information display monitor may respond slowly, and display changes may be delayed.

For example, there is a lag between the driver's shifting and the new gear number appearing on the display. This lag could cause the driver to downshift again, causing rapid and excessive engine braking and possibly an accident resulting in death or injury.

NOTICE

■ To prevent damage to the engine and its components

- Do not let the indicator of the tachometer enter the red zone, which indicates the maximum engine speed.
- The engine may be overheating if the engine coolant temperature gauge is in the red zone (H). In this case, immediately stop the vehicle in a safe place, and check the engine after it has cooled completely. (→P.485)

Odometer and trip meter display

■ Display items

● Odometer

Displays the total distance the vehicle has been driven.

● Trip meter A/trip meter B

Displays the distance the vehicle has been driven since the meter was last reset. Trip meters A and B can be used to record and display different distances independently.

● Stop & Start system operation time

Displays the total idling stop time (engine stop time via the Stop & Start system) after engine start-up.

● Distance until next engine oil change

Displays the distance the vehicle can be driven until an oil change is necessary.

■ Changing the display

Each time the “ODO TRIP” switch is pressed, the displayed item will be changed. When the trip meter is displayed, pressing and holding the switch will reset the trip meter.

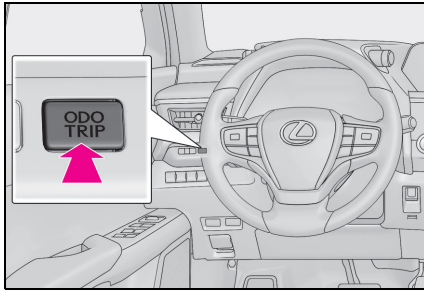

■ Pop-up display

Distance until the next engine oil change will be displayed when a warning message indicating that oil maintenance should be performed soon or is required is displayed.

Changing the instrument panel light brightness

The brightness of the instrument panel lights can be adjusted.

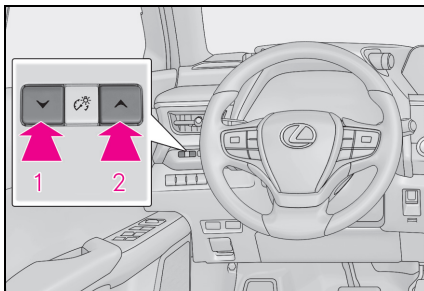

- 1 Darker
- 2 Brighter

■ Instrument panel brightness adjustment

The instrument panel brightness levels when the surroundings are bright (daytime etc.) and dark (nighttime etc.) can be adjusted individually.

Gauges and meters (F SPORT models)

Meter display

■ Locations of gauges and meters

When the main meter is in the side position, some of the meter displays and the gauge layout will change.

► When the main meter is in the center position

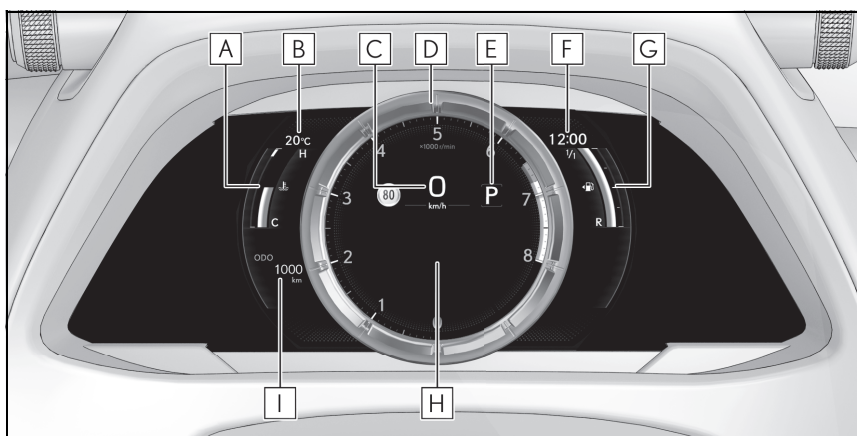

The units of measure may differ depending on the intended destination of the vehicle.

A Engine coolant temperature gauge

Displays the engine coolant temperature

B Outside temperature

Displays the outside temperature within the range of -40°C (-40°F) to 50°C (122°F)

Low outside temperature indicator comes on when the ambient temperature is 3°C (37°F) or lower

C Speedometer

D Tachometer

Displays the engine speed in revolutions per minute

When Sport mode is selected for the driving mode, the periphery of the tachometer will change color and the scale of the tachometer will be emphasized.

- Rev indicator
- Rev peak

E Shift position/shift range (→P.220)

F Clock

Time displayed is linked to the analog clock on the center panel. (→P.380)

G Fuel gauge

Displays the quantity of fuel remaining in the tank

H Multi-information display

Presents the driver with a variety of vehicle data (→P.115)

Displays warning messages if a malfunction occurs (→P.452)

I Odometer and trip meter display (→P.114)

▶ When the main meter is in the side position

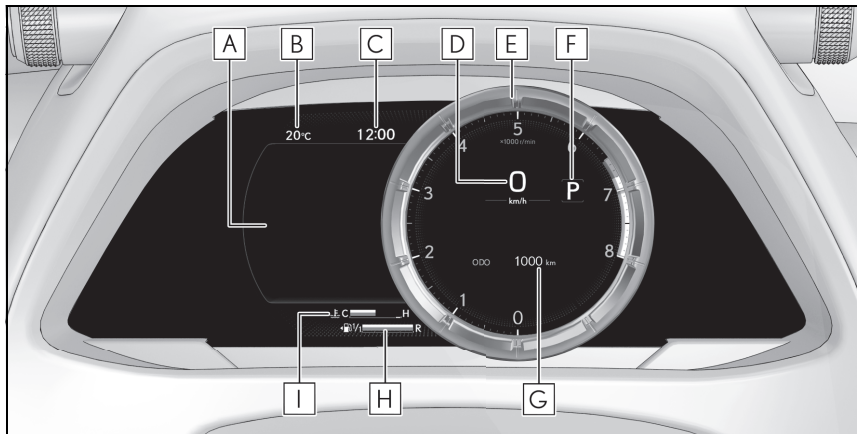

The units of measure may differ depending on the intended destination of the vehicle.

A Multi-information display

Presents the driver with a variety of vehicle data (→P.115)

Displays warning messages if a malfunction occurs (→P.452)

B Outside temperature

Displays the outside temperature within the range of -40°C (-40°F) to 50°C (122°F)

Low outside temperature indicator comes on when the ambient temperature is 3°C (37°F) or lower

C Clock

Time displayed is linked to the analog clock on the center panel. (→P.380)

D Speedometer

E Tachometer

Displays the engine speed in revolutions per minute

When Sport mode is selected for the driving mode, the periphery of the tachometer will

change color and the scale of the tachometer will be emphasized.

- Rev indicator
- Rev peak

F Shift position/shift range (→P.220)

G Odometer and trip meter display (→P.114)

H Fuel gauge

Displays the quantity of fuel remaining in the tank

I Engine coolant temperature gauge

Displays the engine coolant temperature

■ Rev indicator

When the engine speed reaches a set speed or the red zone, a ring-shaped indicator (**A**) will be displayed on the tachometer.

The indicators will be displayed in amber when the engine speed reaches a set speed, and in red when the engine speed reaches the red zone.

The engine speed at which the rev indicator will begin to be displayed can be set on  of the multi-information display. (→P.116)

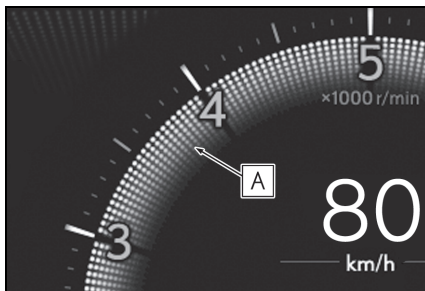

■ Rev peak

When the engine speed reaches or exceeds 5000 r/min, an afterimage of the tachometer will be displayed at the highest engine speed for approximately 1 second.



■ Outside temperature display

- In the following situations, the correct outside temperature may not be displayed, or the display may take longer than normal to change:
 - When stopped, or driving at low speeds (less than 20 km/h [12 mph])
 - When the outside temperature has changed suddenly (at the entrance/exit of a garage, tunnel, etc.)
- When "--" or "E" is displayed, the system may be malfunctioning. Take your vehicle to any authorized Lexus retailer or Lexus authorized repairer, or any reliable repairer.

■ Liquid crystal display

→P.116

■ Customization

The gauges and meters can be customized on  of the multi-information display. (→P.502)

⚠ WARNING**■ The information display at low temperatures**

Allow the interior of the vehicle to warm up before using the liquid crystal information display. At extremely low temperatures, the information display monitor may respond slowly, and display changes may be delayed.

For example, there is a lag between the driver's shifting and the new gear number appearing on the display. This lag could cause the driver to downshift again, causing rapid and excessive engine braking and possibly an accident resulting in death or injury.

⚠ NOTICE**■ To prevent damage to the engine and its components**

- Do not let the indicator of the tachometer enter the red zone, which indicates the maximum engine speed.
- The engine may be overheating if the engine coolant temperature gauge is in the red zone (H). In this case, immediately stop the vehicle in a safe place, and check the engine after it has cooled completely. (→P.485)

Odometer and trip meter display**■ Display items****● Odometer**

Displays the total distance the vehicle has been driven.

● Trip meter A/trip meter B

Displays the distance the vehicle has been driven since the meter was last reset. Trip meters A and B can be used to record and display different distances independently.

● Stop & Start system operation time

Displays the total idling stop time (engine stop time via the Stop & Start system) after engine start-up.

● Distance until next engine oil change

Displays the distance the vehicle can be driven until an oil change is necessary.

■ Changing the display

Each time the "ODO TRIP" switch is pressed, the displayed item will be changed. When the trip meter is displayed, pressing and holding the switch will reset the trip meter.

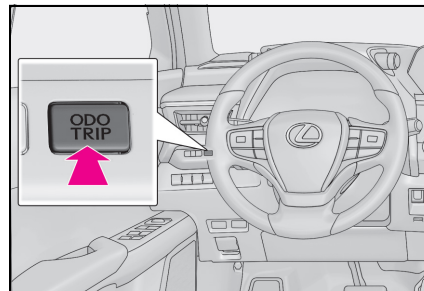
**■ Pop-up display**

Distance until the next engine oil change will displayed when a warning message indicating that oil maintenance should be performed soon or is required is displayed.

Changing the instrument panel light brightness

The brightness of the instrument panel lights can be adjusted.

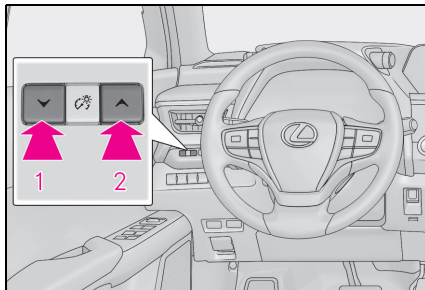

- 1 Darker
- 2 Brighter

■ Instrument panel brightness adjustment

The instrument panel brightness levels when the surroundings are bright (daytime etc.) and dark (nighttime etc.) can be adjusted individually.

Changing the display

The display can be switched between the center and side positions.

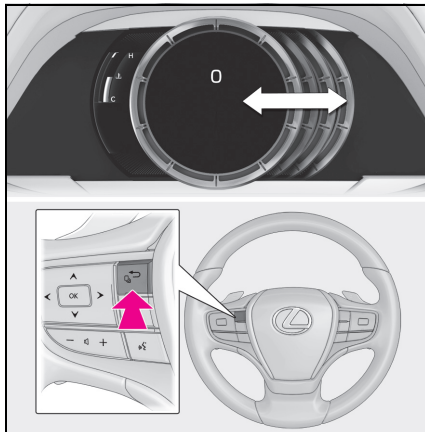

Multi-information display

Display and menu icons

■ Display (except F SPORT models)

By selecting menu icons on the multi-information display, a variety of driving-related information can be displayed. The multi-information display can also be used to change display settings and other vehicle settings.

Warning or suggestion/advice pop-up displays are also displayed in certain situations.



■ Display (F SPORT models)

- ▶ When the main meter is in the center position

The multi-information display presents the driver with a variety of driving-related information.

Warning or suggestion/advice pop-up displays are also displayed in certain situations.

2

Vehicle status information and indicators

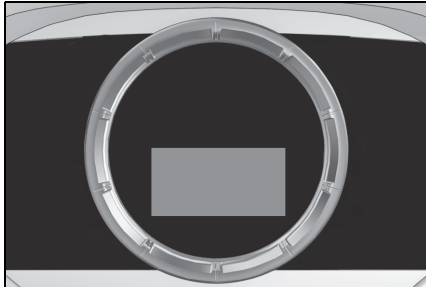

- ▶ When the main meter is in the side position

By selecting menu icons on the multi-information display, a variety of driving-related information can be displayed. The multi-information display can also be used to change display settings and other vehicle settings.







Warning or suggestion/advice pop-up displays are also displayed in certain situations.



■ Menu icons

The menu icons will be displayed by pressing **<** or **>** of the meter control switches (→P.117).

F SPORT models: The menu icons can be displayed when the main meter is in the side position.

-  Driving information display (→P.117)
-  Navigation system-linked display (if equipped) (→P.120)
-  Audio system-linked display (→P.120)
-  Driving support system information display (→P.120)
-  Warning message display (→P.452)
-  Settings display (→P.120)

■ Opening image display

When the engine switch is in ACC or ON, the opening image is displayed on the multi-information display.

While the opening image is being displayed, the meter display cannot be changed even if the drive mode is changed. When the opening image is finished, the meter display for the currently selected mode will be displayed.

■ Liquid crystal display

Small spots or light spots may appear on the display. This phenomenon is characteristic of liquid crystal displays, and there is no problem continuing to use the display.

WARNING

■ Caution for use while driving

- When operating the multi-information display while driving, pay extra attention to the safety of the area around the vehicle.
- Do not look continuously at the multi-information display while driving as you may fail to see pedestrians, objects on the road, etc. ahead of the vehicle.

■ The information display at low temperatures

→P.109, 114

Changing the meter display

The multi-information display is operated using the meter control switches.

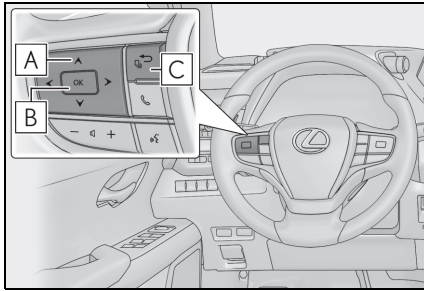

- A** : Select menu icons
 : Change displayed content, scroll up/down the screen or move the cursor up/down
- B** Press: Enter/Set
 Press and hold: Reset
- C** Move the main meter* or return to the previous screen
- *: F SPORT models

Drive information

■ Display items (except F SPORT models)

Press or of the meter control switches and select . Then press or to display the following items:

- Drive information 1
- Drive information 2
- Eco Driving Indicator
- Tire pressure
- Display off

■ Display items (F SPORT models)

- ▶ When the main meter is in the center position

Press or of the meter control switches to display the following items:

- Drive information 1
- Drive information 2
- Tire pressure
- Units
- Display off

- ▶ When the main meter is in the side position

Press or of the meter control switches and select . Then press or to display the following items:

- Drive information 1
- Drive information 2
- Eco Driving Indicator
- G-force
- Tire pressure
- Display off

■ Drive information 1/Drive information 2

2 of the following drive information can be displayed in each screen.

Displayed items can be changed on (→P.116)

Use the displayed values as a reference only.

- Current fuel consumption

Displays instantaneous current fuel consumption

- Average fuel economy

After reset: Displays average fuel consumption since the display was reset^{*1}

After start: Displays average fuel consumption since the engine was started

After refuel: Displays average fuel consumption since refuel

- Average vehicle speed

After reset: Displays average vehicle speed since the display was reset^{*1}

After start: Displays average vehicle speed since the engine was started

- Driven distance

Displays the distance driven since the engine was started

- Elapsed time

After reset: Displays elapsed time since the display was reset^{*1}

After start: Displays elapsed time since the engine was started

- Driving range

Displays driving range with remaining fuel^{*2,3}

- Idling stop time

Displays the idling stop time (engine stop time via the Stop & Start system) after the engine was started

- Other

No item

^{*1}: To reset, display the desired item and press and hold "OK" of the meter control switches.

^{*2}: This distance is computed based on your average fuel consumption. As a result, the actual distance that can be driven may differ from that displayed.

^{*3}: When only a small amount of fuel is added to the tank, the display may not be updated.

When refueling, turn the engine switch off. If the vehicle is refueled without turning the engine switch off, the display may not be updated.

■ Stop & Start system information

- Display items

- Stop & Start system operation time (current)/status notification

Displays the amount of time the engine has been stopped due to the operation of the Stop & Start system since the engine switch is turned to ON. (→P.109, 114)

- Stop & Start system operation time since engine start

- Stop & Start system settings

The length of time the Stop & Start system will operate when the "A/C" switch of the air conditioning system is on can be set to 2 different levels.

This setting can be changed on .

■ Eco Driving Indicator

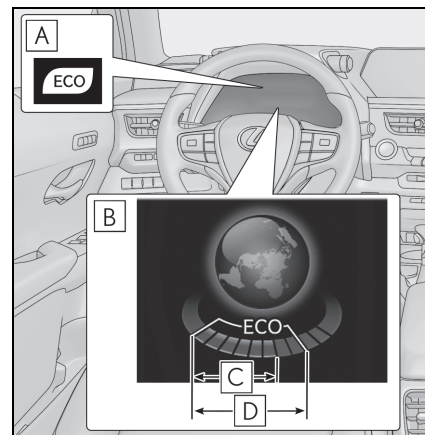

A Eco Driving Indicator Light

During Eco-friendly acceleration (Eco driving), the Eco Driving Indicator Light will turn on. When the acceleration exceeds the Zone of Eco driving, or when the vehicle is stopped, the light turns off.

B Eco Driving Indicator Zone Display
Suggests the Zone of Eco driving with current Eco driving ratio based on acceleration.

C Eco driving ratio based on acceleration

If the acceleration exceeds the Zone of Eco driving, the right side of the Eco Driving Indicator Zone Display will illuminate. At this time, the Eco Driving Indicator Light will turn off.

D Zone of Eco driving

■ G-force (F SPORT models)

Displays lateral G-forces on the vehicle.

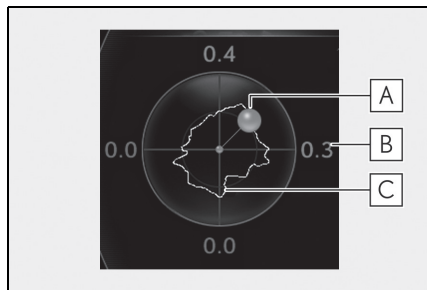

A Acceleration G-force on the vehicle

B Current G-force value (analyzed value of front/rear and left/right G-forces)

C Record of the maximum G-forces

This display is intended for use as a guideline. Depending on factors such as the road

surface condition, temperature and vehicle speed, the display may not show the actual condition of the vehicle.

● Resetting the record of maximum G-forces

Press and hold "OK" of the meter control switches to reset the record.

● Peak hold function

If lateral G-forces of 0.5 G or greater are generated, the G-force value display will turn amber and be held for 2 seconds.

■ Tire pressure

→P.411

■ Units (F SPORT models)

On some models, the units of measure used can be changed while driving.

Unlike the units setting performed on the settings display, the units setting performed on the drive information display can be changed while driving.

■ Display OFF

Displays a blank screen.

■ Eco Driving Indicator

Eco Driving Indicator will not operate under the following conditions:

- The shift lever is in any position other than D.
- A paddle shift switch (if equipped) is operated.
- The driving mode is set to other than normal and Eco drive mode.
- The vehicle speed is approximately 130 km/h (80 mph) or higher.

Navigation system-linked display (if equipped)

Select to display the following navigation system-linked information.

- Route guidance to destination
- Compass display

■ Route guidance to destination display

When the route guidance to destination display is enabled on the head-up display, it will not be displayed on the multi-information display. (→P.122)

Audio system-linked display

Select to enable selection of an audio source or track on the meter using the meter control switches.

Driving support system information display

Select to display the operational status of the following systems:

- LTA (Lane Tracing Assist) (if equipped) (→P.268)
- Dynamic radar cruise control with full-speed range (if equipped) (→P.281)
- Cruise control (if equipped) (→P.292)
- RSA (Road Sign Assist) (if equipped) (→P.277)

Warning message display

Select to display warning messages

and measures to be taken if a malfunction is detected. (→P.452)

Settings display

■ Meter display settings that can be changed

- Language

Select to change the language displayed.

- Units

Select to change the units of measure displayed.

- Speedometer display (except F SPORT models)

Select to set the display of the speedometer to digital/analog.

- Drive information 1/Drive information 2

Select to select up to 2 items (→P.117) that will be displayed on each Drive information screen (Drive information 1 screen and Drive information 2 screen) respectively.

- Clock

Select to switch between 24-hour display and 12-hour display.

- Pop-up display

Select to enable/disable pop-up displays for each relevant system.

- Accent color

Select to change the accent color on the screen, such as the cursor color.

- Rev indicator (F SPORT models)

• Select to enable/disable the rev indicator.

• Select to set the engine speed at which the rev indicator (amber) will begin to be

displayed.

- Rev peak (F SPORT models)

Select to enable/disable the rev peak.

- Eco Driving Indicator Light

Select to enable/disable the Eco Driving Indicator Light.

- Default setting

Select to reset the meter display settings to the default setting.

■ Suspension of the settings display

- Some settings cannot be changed while driving. When changing settings, park the vehicle in a safe place.
- If a warning message is displayed, operation of the settings display will be suspended.



WARNING

■ Cautions during setting up the display

As the engine needs to be running during setting up the display, ensure that the vehicle is parked in a place with adequate ventilation. In a closed area such as a garage, exhaust gases including harmful carbon monoxide (CO) may collect and enter the vehicle. This may lead to death or a serious health hazard.



NOTICE

■ During setting up the display

To prevent battery discharge, ensure that the engine is running while setting up the display features.

Suggestion function

Displays suggestions to the driver in the following situations. To select a response to a displayed suggestion,

use the meter control switches.

■ Suggestion to enable the power back door

If the power back door system is disabled on  of the multi-information display (→P.116) and the power back door switch on the instrument panel is operated, a suggestion message will be displayed asking if you wish to enable the power back door system. To enable the power back door system, select "Yes".

After enabling the power back door system, press the power back door switch again to open or close the power back door.

■ Suggestion to turn on the headlights

If the headlight switch is in other than  or AUTO position, and the vehicle speed is 5 km/h (3 mph) or higher for a certain amount of time when the surroundings are dark, a suggestion message will be displayed.

■ Suggestion to turn off the headlights

If the headlights are left on for a certain amount of time with the headlight switch in AUTO after the engine switch has been turned off, a suggestion message will be displayed asking if you wish to turn the headlights off.

To turn the headlights off, select "Yes".

If a front door is opened after the engine switch is turned off, this suggestion mes-

sage will not be displayed.

■ **Suggestion to close the power windows (linked to windshield wiper operation)**

If the windshield wipers are operated with a power window open, a suggestion message will be displayed asking if you wish to close the power windows.

To close all of the power windows, select “Yes”.

■ **Customization**

Some functions can be customized. (→P.502)

Head-up display *

*: If equipped

The head-up display projects a variety of driving-related information and the operating state of the driving support systems on the windshield.

System components

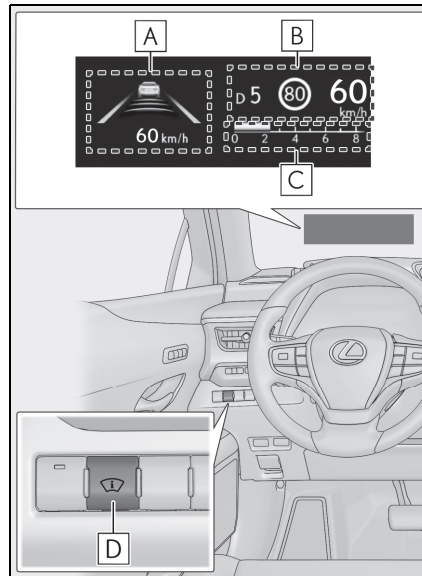

Illustrations used in this text are intended as examples, and may differ from the image that is actually displayed by the head-up display.

A Driving support system display area (→P.125)

Navigation system-linked display area (if equipped)

Displays the following items which are linked to the navigation system:

- Route guidance to destination

- Street name
- Compass (heading-up display)

B Driving information display area

Displays the following items:

- Speedometer
- Shift position/shift range (→P.220)
- RSA (Road Sign Assist) (if equipped) (→P.277)

C Tachometer/Eco Driving Indicator display area (→P.126)

D Head-up display switch

■ **Head-up display will operate when**

The engine switch is in ON.

■ **When using the head-up display**

The head-up display may seem dark or hard to see when viewed through sunglasses, especially polarized sunglasses. Adjust the brightness of the head-up display or remove your sunglasses.

■ **Street name display**

Only street names which are included in the map data will be displayed.

■ **Outside temperature display**

- In the following situations, the outside temperature is displayed.
 - When the ambient temperature is approximately 37°F (3°C) or lower (In this case, the outside temperature display will be displayed and the low outside temperature indicator will flash for approximately 10 seconds.)
 - After the opening image (→P.116) is displayed (The outside temperature display will be displayed for approximately 10 seconds.)
- In the following situations, the correct outside temperature may not be displayed, or the display may take longer than normal to change:
 - When stopped, or driving at low speeds (less than 20 km/h [12 mph])
 - When the outside temperature has changed suddenly (at the entrance/exit of

a garage, tunnel, etc.)

- When "--" or "E" is displayed, the system may be malfunctioning. Take your vehicle to any authorized Lexus retailer or Lexus authorized repairer, or any reliable repairer.

WARNING

■ **When using the head-up display**

- Check that the position and brightness of the head-up display image does not interfere with safe driving. Incorrect adjustment of the image's position or brightness may obstruct the driver's view and lead to an accident, resulting in death or serious injury.
- Do not continuously look at the head-up display while driving as you may fail to see pedestrians, objects on the road, etc. ahead of the vehicle.

NOTICE

■ **Head-up display projector**

- Do not place any drinks near the head-up display projector. If the projector gets wet, electrical malfunctions may result.

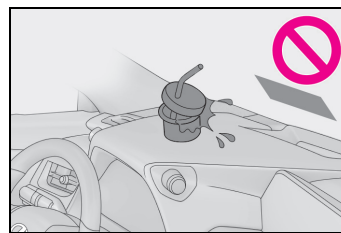

- Do not place anything on or put stickers onto the head-up display projector. Doing so could interrupt head-up display indications.
- Do not touch the inside of the head-up display projector or thrust sharp edges or the like into the projector. Doing so could cause mechanical malfunctions.

Using the head-up display

■ Enabling/disabling the head-up display

Press the head-up display switch.

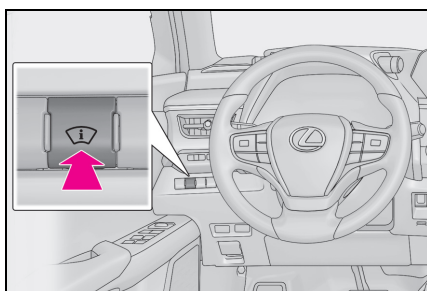

■ Changing settings of the head-up display

The following settings can be changed on  of the multi-information display. (→P.116)

- Brightness and vertical position of the head-up display

Select to adjust the brightness or vertical position of the head-up display.

- Tachometer/Eco Driving Indicator

Select to display the tachometer, Eco Driving Indicator or no content.

- Display content

Select to enable/disable the following items:

- Route guidance to destination/street name
- Driving support system display*
- Compass (heading-up display)
- Audio system operation status

*: Make sure to enable this display when using the driving support systems

- Display angle

Select to adjust the angle of the head-up display.

■ Enabling/disabling of the head-up display

If the head-up display is disabled, it will remain disabled when the engine switch is turned off then back to ON.

■ Display brightness

The brightness of the head-up display can be adjusted on  of the multi-information display. Also, it is automatically adjusted according to the ambient brightness.

■ Head-up display automatic position adjustment (vehicles with driving position memory)

If the display position is recorded into memory, the head-up display will be automatically adjusted to the desired position. (→P.187)

■ When the battery is disconnected

The customize settings of the head-up display will be reset.

WARNING

■ Caution for changing settings of the head-up display

As the engine needs to be running while changing the settings of the head-up display, ensure that the vehicle is parked in a place with adequate ventilation. In a closed area such as a garage, exhaust gases including harmful carbon monoxide (CO) may collect and enter the vehicle. This may lead to death or a serious health hazard.

**NOTICE****■ When changing the settings of the head-up display**

To prevent battery discharge, ensure that the engine is running while changing the settings of the head-up display.

Driving support system display area

Displays the operational status of the following systems:

- LTA (Lane Tracing Assist) (if equipped) (→P.268)
- Dynamic radar cruise control with full-speed range (if equipped) (→P.281)

Details of content displayed on the head-up display may differ from that displayed on the multi-information display. For details, refer to the explanation of each system.

Pop-up display

Pop-up displays for the following systems will be displayed when necessary.

■ Driving support systems

Displays a warning/suggestion/advice message or the operating state of a relevant system.

- PCS (Pre-Collision System) (if equipped) (→P.260)
- Lexus parking assist-sensor (if equipped) (→P.313)
- Parking Support Brake function (for static objects) (if equipped) (→P.328)

- Brake Override System (→P.205)

- Drive-Start Control (→P.205)

Details of content displayed on the head-up display may differ from that displayed on the multi-information display. For details, refer to the explanation of each system.

■   icons

These icons are linked to the multi-information display

: Master warning icon

Displayed when a warning message is displayed on the multi-information display. (→P.452)

: Information icon

Displayed when a suggestion pop-up display (→P.121) or advice pop-up display is displayed on the multi-information display.

■ Warning message

Some warning messages are displayed when necessary, according to certain conditions.

Details of content displayed on the head-up display may differ from that displayed on the multi-information display.

■ Audio system operation status

Displayed when an audio remote control switch on the steering wheel is operated.

■ Hands-free system status

Displayed when the hands-free system is operated.

■ When a pop-up display is displayed

When a pop-up display is displayed, a current display may no longer be displayed. In

this case, the display will return after the pop-up display disappears.

Tachometer/Eco Driving Indicator display area

■ **Tachometer**

Displays the engine speed in revolutions per minute.

■ **Eco Driving Indicator**

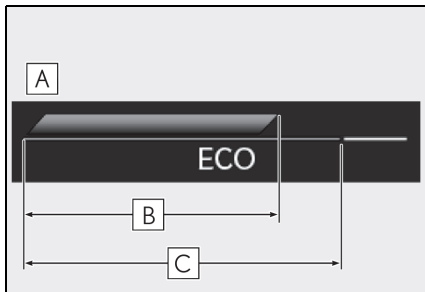

A Eco Driving Indicator Zone Display

B Eco driving ratio based on acceleration

C Zone of Eco driving

Displayed content is the same as that displayed on the multi-information display (Eco Driving Indicator). For details, refer to P.118.

Fuel consumption information

Fuel consumption information can be displayed on the multi-information display and Center Display.

10.3-inch display model: The consumption screen can be displayed on the side display.

System components

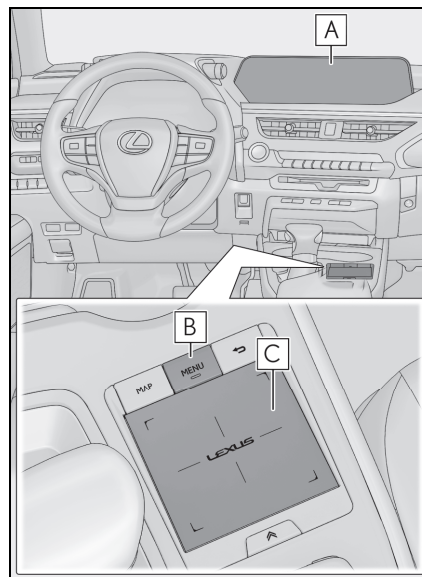

A Center Display

B "MENU" button

C Touchpad

Consumption

Press the "MENU" button on the Remote Touch, and then select  on

the menu screen.

■ Trip information

If a screen other than “Trip information” is displayed, select “Trip information”.

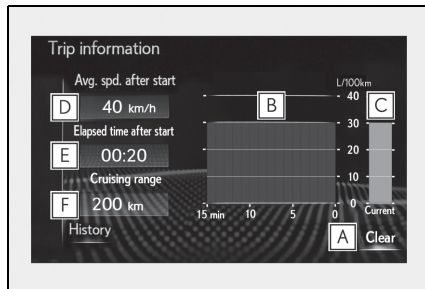

- A** Resetting the consumption data
- B** Fuel consumption in the past 15 minutes
- C** Current fuel consumption
- D** Average vehicle speed since the engine was started.
- E** Elapsed time since the engine was started.
- F** Cruising range

Average fuel consumption for the past 15 minutes is divided by color into past averages and averages attained since the engine switch was last turned to ON. Use the displayed average fuel consumption as a reference.

The image is an example only, and may vary slightly from actual conditions.

■ History

If a screen other than “History” is displayed, select “History”.

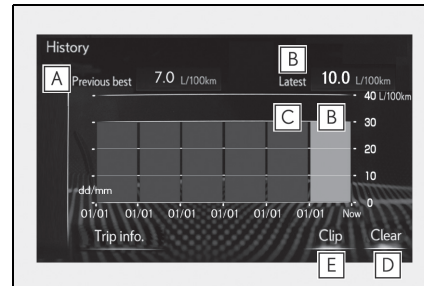

- A** Best recorded fuel consumption
- B** Latest fuel consumption
- C** Previous fuel consumption record
- D** Resetting the History data
- E** Updating the latest fuel consumption data

The latest fuel consumption history is divided by color into past averages and the average fuel consumption since the last updated. Use the displayed average fuel consumption as a reference.

The image is an example only, and may vary slightly from actual conditions.

■ Updating the History data

Update the latest fuel consumption by selecting “Clip” to measure the current fuel consumption again.

■ Resetting the data

The fuel consumption data can be deleted by selecting “Clear”.

■ Cruising range

Displays the estimated maximum distance that can be driven with the quantity of fuel remaining.

This distance is computed based on your average fuel consumption. As a result, the actual distance that can be driven may differ from that displayed.

Using the side display (10.3-inch display model)

Display the vehicle information on the side display (→P.353) and then select **<** or **>** to display the desired screen.

■ **Trip information (type A)**

Displays the average fuel consumption for the past 10 minutes in 1 minute intervals, as well as the cruising range.

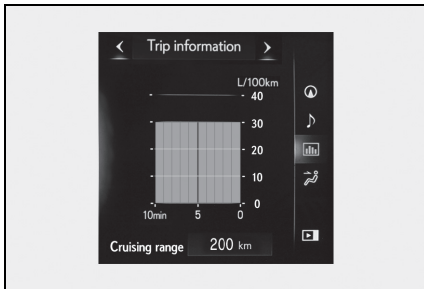

The image is an example only, and may vary slightly from actual conditions.
Use the displayed average fuel consumption as a reference.

■ **Trip information (type B)**

Displays the cruising range, latest fuel consumption and the amount of time elapsed since the engine was started.

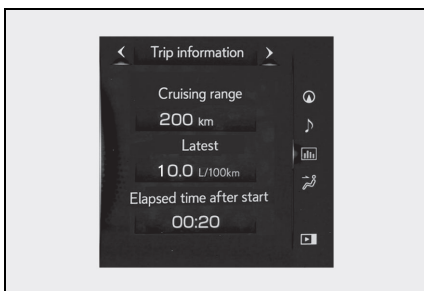

The image is an example only, and may

vary slightly from actual conditions.

Use the displayed average fuel consumption as a reference.

■ **History**

Displays the average fuel consumption, previous average fuel consumption and highest fuel consumption.

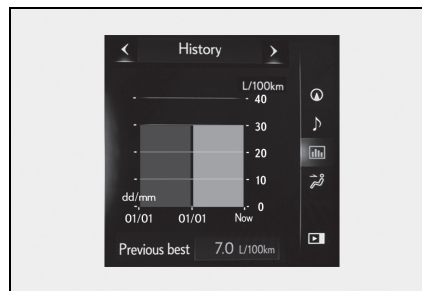

The image is an example only, and may vary slightly from actual conditions.

Use the displayed average fuel consumption as a reference.

- 3-1. Key information
 - Keys 130
- 3-2. Opening, closing and locking the doors
 - Side doors 134
 - Back door 138
 - Smart entry & start system 151
- 3-3. Adjusting the seats
 - Front seats 184
 - Rear seats 185
 - Driving position memory 187
 - Head restraints 190
- 3-4. Adjusting the steering wheel and mirrors
 - Steering wheel 192
 - Inside rear view mirror 193
 - Outside rear view mirrors 195
- 3-5. Opening, closing the windows and moon roof
 - Power windows 197
 - Moon roof 199

Keys

Key types

The following keys are provided with the vehicle.

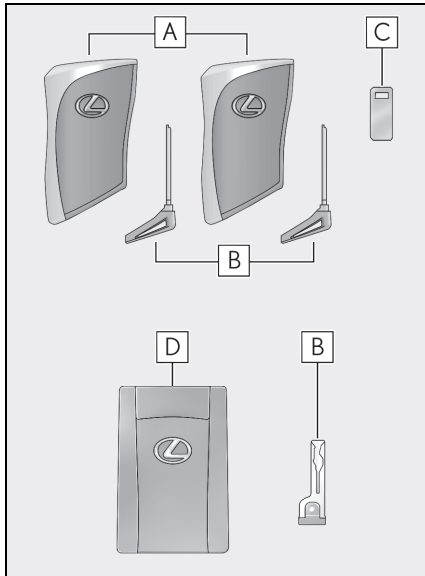

- A** Electronic keys
- Operating the smart entry & start system (if equipped) (→P.151)
 - Operating the wireless remote control function

- B** Mechanical keys

- C** Key number plate

- D** Card key (electronic key) (if equipped)

Operating the smart entry & start system (→P.151)

■ Card key (if equipped)

- The mechanical key that is stored inside the card key should be used only if a problem arises, such as when the card

key does not operate properly.

- If the battery cover is not installed and the battery falls out or if the battery was removed because the key got wet, reinstall the battery with the positive terminal facing the Lexus emblem.

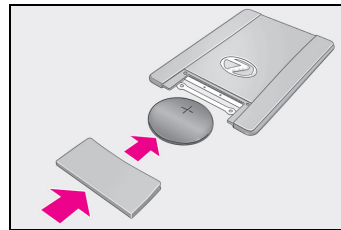

- The card key is not waterproof.

■ When riding in an aircraft

When bringing an electronic key onto an aircraft, make sure you do not press any buttons on the electronic key while inside the aircraft cabin. If you are carrying an electronic key in your bag, etc., ensure that the buttons are not likely to be pressed accidentally. Pressing a button may cause the electronic key to emit radio waves that could interfere with the operation of the aircraft.

■ Electronic key battery depletion

- The standard battery life is 1 to 2 years. (The card key battery life is about a year and a half.)
- If the battery becomes low, an alarm will sound in the cabin when the engine stops.
- To reduce key battery depletion when the electronic key is to not be used for long periods of time, set the electronic key to the battery-saving mode. (→P.153)
- As the electronic key always receives radio waves, the battery will become depleted even if the electronic key is not used. The following symptoms indicate that the electronic key battery may be depleted. Replace the battery when necessary. (→P.428)
 - The smart entry & start system or the wireless remote control does not operate.
 - The detection area becomes smaller.
 - The LED indicator on the key surface

does not turn on.

- To avoid serious deterioration, do not leave the electronic key within 1 m (3 ft.) of the following electrical appliances that produce a magnetic field:
 - TVs
 - Personal computers
 - Cellular phones, cordless phones and battery chargers
 - Recharging cellular phones or cordless phones
 - Table lamps
 - Induction cookers

You can replace the battery by yourself (→P.428). However, as there is a danger that the electronic key may be damaged, it is recommended that replacement be carried out by any authorized Lexus retailer or Lexus authorized repairer, or any reliable repairer.

■ Replacing the battery

→P.428

■ Confirmation of the registered key number

The number of keys already registered to the vehicle can be confirmed. Ask any authorized Lexus retailer or Lexus authorized repairer, or any reliable repairer for details.

■ If “A New Key has been Registered Contact Your Dealer for Details” is shown on the multi-information display

This message will be displayed each time the driver’s door is opened when the doors are unlocked from the outside for approximately 10 days after a new electronic key has been registered.

If this message is displayed but you have not had a new electronic key registered, ask any authorized Lexus retailer or Lexus authorized repairer, or any reliable repairer to check if an unknown electronic key (other than those in your possession) has been registered.



NOTICE

■ To prevent key damage

- Do not drop the keys, subject them to strong shocks or bend them.
- Do not expose the keys to high temperatures for long periods of time.
- Do not get the keys wet or wash them in an ultrasonic washer, etc.
- Do not attach metallic or magnetic materials to the keys or place the keys close to such materials.
- Do not disassemble the keys.
- Do not attach a sticker or anything else to the surface of the electronic key.
- Do not place the keys near objects that produce magnetic fields, such as TVs, audio systems and induction cookers, or medical electrical equipment, such as low-frequency therapy equipment.

■ Carrying the electronic key on your person

Carry the electronic key 10 cm (3.9 in.) or more away from electric appliances that are turned on. Radio waves emitted from electric appliances within 10 cm (3.9 in.) of the electronic key may interfere with the key, causing the key to not function properly.

■ In case of a smart entry & start system malfunction or other key related problems

→P.480

■ When an electronic key is lost

→P.479

 NOTICE

■ Handling the card key

- If the battery or card key terminals get wet, the battery may corrode and the card key may stop working. If the key is dropped into water, or if drinking water, etc., is spilled on the key, immediately remove the battery cover and wipe the battery and terminals. (To remove the battery cover, lightly grasp and pull it.) If the battery is corroded, have any authorized Lexus retailer or Lexus authorized repairer, or any reliable repairer replace the battery.
- Do not crush the battery cover or use a screwdriver to remove the battery cover. Forcibly removing the battery cover may bend or damage the key.
- If the battery cover is frequently removed, the battery cover may become loose.
- When installing the battery, make sure to check the direction of the battery. Installing the battery in the wrong direction may cause the battery to deplete rapidly.
- The surface of the card key may be damaged, or its coating may peel off in the following situations:
 - The card key is carried together with hard objects, such as coins and keys.
 - The card key is scraped with a sharp object, such as the tip of a mechanical pencil.
 - The surface of the card key is wiped with thinner or benzene.

Wireless remote control

The electronic keys are equipped with the following wireless remote control:

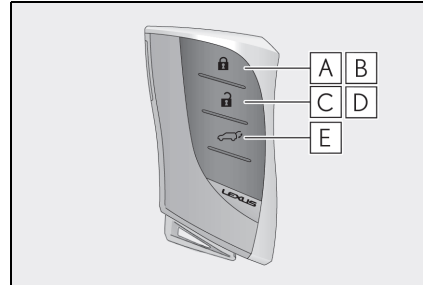

- A** Locks all the doors (→P.134)
- B** Closes the windows and moon roof^{*1,2} (→P.134)
- C** Unlocks all the doors (→P.134)
- D** Opens the windows and moon roof^{*1,2} (→P.134)
- E** Opens and closes the power back door^{*1} (→P.141)

^{*1}: If equipped

^{*2}: These settings must be customized at any authorized Lexus retailer or Lexus authorized repairer, or any reliable repairer.

■ Back door reserve lock function (vehicles with power back door)

This function reserves locking of all doors, beforehand, when the back door is open. When the following is done, all the doors except the back door are locked and then back door will also be locked at the same time it is closed.

- 1 Close all doors, except the back door.
- 2 Push the wireless lock button during the automatic closing operation of the back door.

Using the mechanical key

To take out the mechanical key, push the release button and take the key out.

The mechanical key can only be inserted in one direction, as the key only has grooves on one side. If the key cannot be inserted in a lock cylinder, turn it over and re-attempt to insert it.

After using the mechanical key, store it in the electronic key. Carry the mechanical key together with the electronic key. If the electronic key battery is depleted or the entry function does not operate properly, you will need the mechanical key. (→P.480)

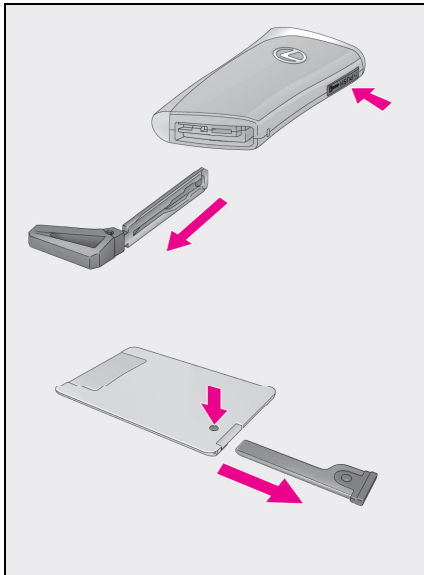

■ When required to leave the vehicle's key with a parking attendant

Lock the glove box as circumstances demand. (→P.373)

Remove the mechanical key for your own use and provide the attendant with the electronic key only.

■ If you lose your mechanical keys

→P.479

■ If a wrong key is used

The key cylinder rotates freely to isolate inside mechanism.

■ Card key (if equipped)

- If it is difficult to take out the mechanical key, push down the release button using a pen tip, etc. If it is still difficult to pull it out, use a coin, etc.
- To store the mechanical key in the card key, insert it while pressing the release button.

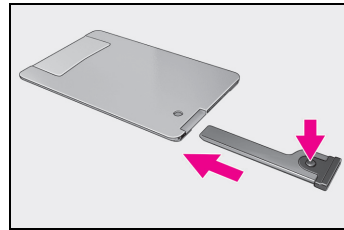

⚠ NOTICE

■ Handling the card key

Do not apply excess force when inserting the mechanical key into the card key. Doing so may damage the card key.

Side doors

Unlocking and locking the doors from the outside

■ Smart entry & start system (vehicles with entry function)

Carry the electronic key to enable this function.

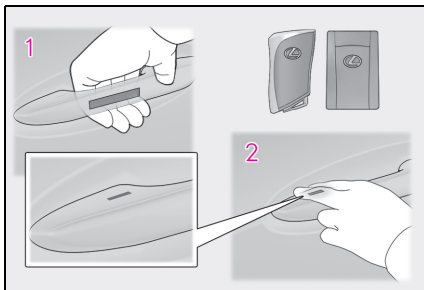

- 1 Grip the front door handle to unlock the doors.*

Make sure to touch the sensor on the back of the handle.

The doors cannot be unlocked for 3 seconds after the doors are locked.

*: The door unlock settings can be changed.

- 2 Touch the lock sensor (the indentation on the upper part of the front door handle) to lock all the doors.

Check that the door is securely locked.

■ Wireless remote control

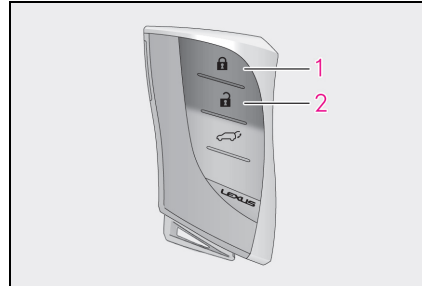

- 1 Locks all the doors

Check that the door is securely locked. Press and hold to close the windows and moon roof.*^{1,2}

- 2 Unlocks all the doors



Press and hold to open the windows and moon roof.*^{1,2}

*¹: If equipped

*²: These settings must be customized at any authorized Lexus retailer or Lexus authorized repairer, or any reliable repairer.



■ Switching the door unlock function

It is possible to set which doors the entry function unlocks using the wireless remote control.

- 1 Turn the engine switch off.
- 2 Cancel the intrusion sensor and tilt sensor of the alarm system to prevent unintended triggering of the alarm while changing the settings. (if equipped) (→P.99)
- 3 When the indicator light on the key surface is not on, press and hold  or  for approximately 5 seconds while pressing and holding .

The setting changes each time an operation is performed, as shown below. (When changing the setting continuously, release the buttons, wait for at least 5 seconds, and

repeat step 3.)

Multi-information display/Beep	Unlocking function
 (Left-hand drive vehicles)	Holding the driver's door handle unlocks only the driver's door.
 (Right-hand drive vehicles) Exterior: Beeps 3 times Interior: Pings once	Holding the front passenger door handle unlocks all the doors.
 Exterior: Beeps twice Interior: Pings once	Holding a front door handle unlocks all the doors.

For vehicles with alarm: To prevent unintended triggering of the alarm, unlock the doors using the wireless remote control and open and close a door once after the settings have been changed. (If a door is not opened within 30 seconds after  is pressed, the doors will be locked again and the alarm will automatically be set.) In a case that the alarm is triggered, immediately stop the alarm. (→P.98)

■ Locking the front doors from the outside without a key

- 1 Push down the inside lock button. (→P.136)
- 2 Close the door while pulling the door handle.

The door cannot be locked if the engine switch is in ACC or ON, or the electronic key is left inside the vehicle.

The key may not be detected correctly and the door may be locked.

■ Impact detection door lock release system

In the event that the vehicle is subject to a strong impact, all the doors are unlocked. Depending on the force of the impact or the type of accident, however, the system may not operate.

■ Operation signals

The emergency flashers flash to indicate that the doors have been locked/unlocked. (Locked: once; Unlocked: twice)

A buzzer sounds to indicate that the windows are operating.

■ Security feature

If a door is not opened within approximately 30 seconds after the vehicle is unlocked, the security feature automatically locks the vehicle again.

■ When the door cannot be locked by the lock sensor on the upper part of the door handle (vehicles with entry function)

When the door cannot be locked even if the lock sensor on the upper part of the door handle is touched by a finger, touch the lock sensor with the palm.

When gloves are being worn, remove the gloves.

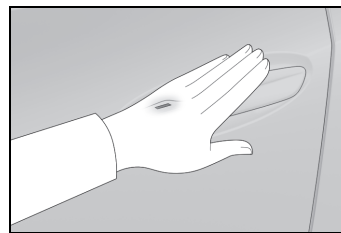

■ Open door warning buzzer

If an attempt to lock the doors is made when a door is not fully closed, a buzzer sounds continuously for 5 seconds. Fully close the door to stop the buzzer, and lock the vehicle once more.

■ Setting the alarm (if equipped)

Locking the doors will set the alarm system. (→P.97)

■ **Conditions affecting the operation of the smart entry & start system or wireless remote control**

→P.153

■ **If the smart entry & start system or the wireless remote control does not operate properly**

- Use the mechanical key to lock and unlock the doors. (→P.480)
- Replace the key battery with a new one if it is depleted. (→P.428)

■ **If the battery is discharged**

The doors cannot be locked and unlocked using the smart entry & start system or wireless remote control. Lock or unlock the doors using the mechanical key. (→P.480)

■ **Customization**

Settings (e.g. unlocking function using a key) can be changed. (Customizable features: →P.504)

⚠ WARNING

■ **To prevent an accident**

Observe the following precautions while driving the vehicle.

Failure to do so may result in a door opening and an occupant falling out, resulting in death or serious injury.

- Ensure that all doors are properly closed and locked.
- Do not pull the inside handle of the doors while driving. Be especially careful for the front doors, as the doors may be opened even if the inside lock buttons are in locked position.
- Set the rear door child-protector locks when children are seated in the rear seats.

■ **When opening or closing a door**

Check the surroundings of the vehicle such as whether the vehicle is on an incline, whether there is enough space for a door to open and whether a strong wind is blowing. When opening or closing the door, hold the door handle tightly to prepare for any unpredictable movement.

■ **When using the wireless remote control and operating the power windows or moon roof (if equipped)**

Operate the power window or moon roof after checking to make sure that there is no possibility of any passenger having any of their body parts caught in the window or moon roof. Also, do not allow children to operate the wireless remote control. It is possible for children and other passengers to get caught in the power window or moon roof.

Unlocking and locking the doors from the inside

■ **Door lock switches (to lock/unlock)**

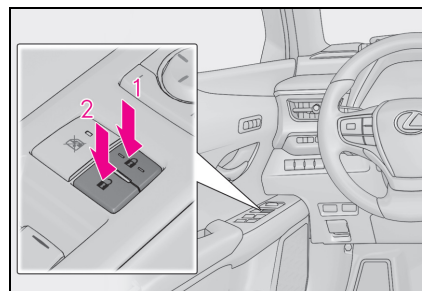

- 1 Locks all the doors
- 2 Unlocks all the doors

■ **Inside lock buttons (to lock)**

Push down the inside lock button to lock the door.

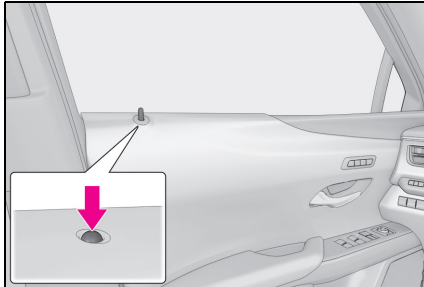

■ Inside door handles (to unlock)

► For the front doors

Pull the handle to unlock and open the door.

When the door is unlocked, the inside lock button will pop up.

► For the rear doors

Pull the handle to unlock the door. Pull the handle a second time to open the door.

When the door is unlocked, the inside lock button will pop up.

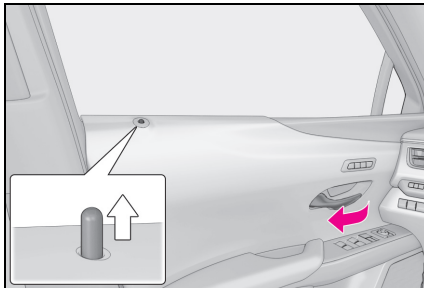

■ If a symbol indicating one or more doors are open is shown on the multi-information display

The hood or one or more of the doors are not fully closed. The system also indicates which doors are not fully closed. If the vehicle reaches a speed of 5 km/h (3 mph), a buzzer sounds to indicate that the door(s) are not yet fully closed. Make sure that the hood and all the doors are closed.

Rear door child-protector lock

The door cannot be opened from inside the vehicle when the lock is set.

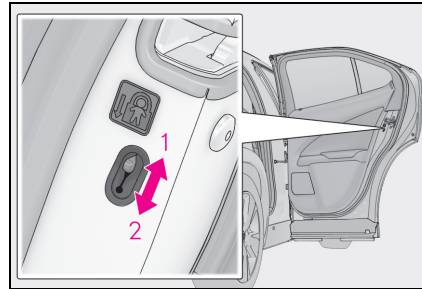

1 Unlock

2 Lock

These locks can be set to prevent children from opening the rear doors. Push down on each rear door switch to lock both rear doors.

Automatic door locking and unlocking systems

The following functions can be set or canceled:

For instructions on customizing, refer to P.504.

Function	Operation
Speed linked door locking function	All doors are automatically locked when vehicle speed is approximately 20 km/h (12 mph) or higher.
Shift position linked door locking function	All doors are automatically locked when shifting the shift lever out of P.

Function	Operation
Shift position linked door unlocking function	All doors are automatically unlocked when shifting the shift lever to P.
Driver's door linked door unlocking function	All doors are automatically unlocked when driver's door is opened within approximately 45 seconds after turning the engine switch off.

Back door

The back door can be locked/unlocked and opened/closed by the following procedures.

WARNING

Observe the following precautions.

Failure to do so may cause parts of the body to be caught, resulting in death or serious injury.

■ Before driving the vehicle

Before driving the vehicle, make sure that the back door is fully closed. If the back door is not fully closed, it may open unexpectedly while driving, causing an accident.

■ Caution while driving

- Keep the back door closed while driving.

If the back door is left open, it may hit nearby objects while driving or luggage may be unexpectedly thrown out, causing an accident.

In addition, exhaust gases may enter the vehicle, causing death or a serious health hazard. Make sure to close the back door before driving.

- Never let anyone sit in the luggage compartment. In the event of sudden braking, sudden swerving or a collision, they are susceptible to death or serious injury.

■ When children are in the vehicle

Observe the following precautions. Failure to do so may result in death or serious injury.

- Do not allow children to play in the luggage compartment.

If a child is accidentally locked in the luggage compartment, they could have heat exhaustion or other injuries.

⚠ WARNING

- Do not allow a child to open or close the back door.
Doing so may cause the back door to move unexpectedly, or cause the child's hands, arms, head, or neck to be caught by the closing back door.

■ Operating the back door

Observe the following precautions. Failure to do so may cause parts of the body to be caught, resulting in death or serious injury.

- Remove any heavy loads, such as snow and ice, from the back door before opening it. Failure to do so may cause the back door to suddenly shut again after it is opened.
- When opening or closing the back door, thoroughly check to make sure the surrounding area is safe.
- If anyone is in the vicinity, make sure they are safe and let them know that the back door is about to open or close.
- Use caution when opening or closing the back door in windy weather as it may move abruptly in strong wind.
- Vehicles without power back door: The back door may suddenly shut if it is not opened fully. It is more difficult to open or close the back door on an incline than on a level surface, so beware of the back door unexpectedly opening or closing by itself. Make sure that the back door is fully open and secured before using the luggage compartment.

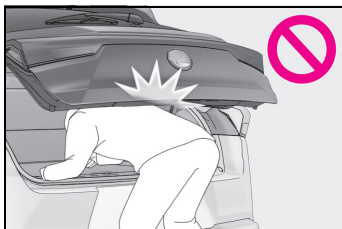

- Vehicles with power back door: The back door may suddenly shut if it is not opened fully, while on a steep incline. Make sure that the back door is secured before using the luggage compartment.
- When closing the back door, take extra care to prevent your fingers, etc., from being caught.



- When closing the back door, make sure to press it lightly on its outer surface. If the back door handle is used to fully close the back door, it may result in hands or arms being caught.
- Do not pull on the back door damper stay (vehicles without power back door) (→P.141) or back door spindle (vehicles with power back door) (→P.148) to close the back door, and do not hang on the back door damper stay (vehicles without power back door) or back door spindle (vehicles with power back door) to break, causing an accident.
- If a bicycle carrier or similar heavy object is attached to the back door, it may suddenly shut again after being opened, causing someone's hands, arms, head or neck to be caught and injured. When installing an accessory part to the back door, using a genuine Lexus part is recommended.

Unlocking and locking the back door from the outside

■ **Smart entry & start system (vehicles with entry function)**

Carry the electronic key to enable this function.

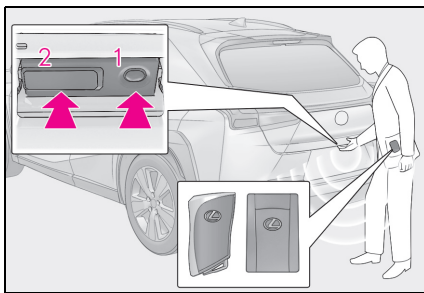

- 1** Locks all the doors
Check that the door is securely locked.
- 2** Unlocks all the doors
The doors cannot be unlocked for 3 seconds after the doors are locked.

■ **Wireless remote control**

→P.132

Unlocking and locking the back door from the inside

■ **Door lock switch**

→P.136

Opening/closing the back door (vehicles without power back door)

■ **Open**

Raise the back door while pressing up the back door opener switch.

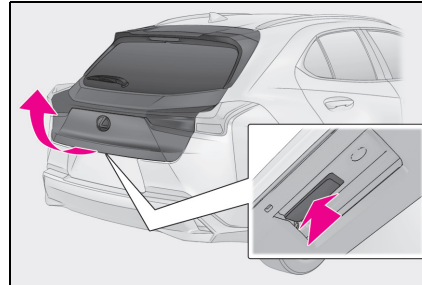

■ **Close**

Lower the back door using the back door handle, and make sure to push the back door down from the outside to close it.

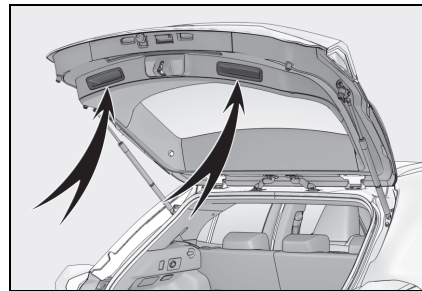

■ **Luggage compartment light**

- The luggage compartment light turns on when the back door is opened.
- If the luggage compartment light is left on when the engine switch is turned off, the light will go off automatically after 20 minutes.

■ **If the back door opener is inoperative**

The back door can be unlocked from the inside.

- 1** Remove the cover.

To protect the cover, place a rag between the flathead screwdriver and the cover as shown in the illustration.

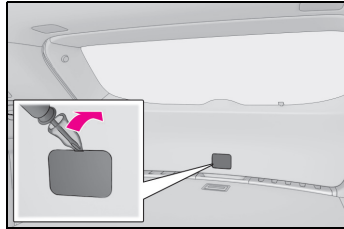

2 Loosen the screw and move the cover.

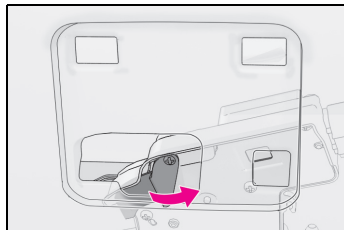

3 Move the lever.

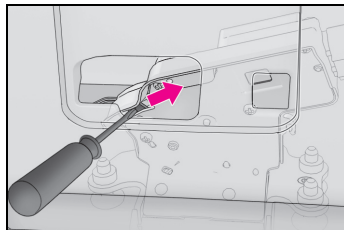

 NOTICE

■ **Back door damper stays**

The back door is equipped with damper stays **A** that hold the back door in place.

Observe the following precautions.

Failure to do so may cause damage to the back door damper stay **A**, resulting in malfunction.

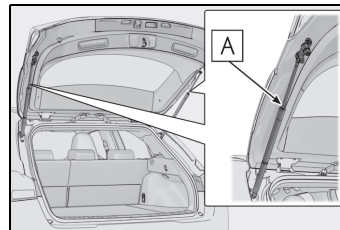

- Do not attach any foreign objects, such as stickers, plastic sheets, or adhesives to the damper stay rod.
- Do not touch the damper stay rod with gloves or other fabric items.
- Do not attach any accessories other than genuine Lexus parts to the back door.
- Do not place your hand on the damper stay or apply lateral forces to it.

Opening/closing the back door (vehicles with power back door)

■ **Opening/closing the back door using the wireless remote control**

Press the switch for 1 second.

The power back door can be operated only when the back door is unlocked.

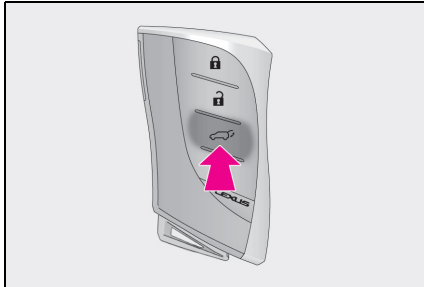

■ Opening/closing the back door from the inside

Press the switch for 1 second.

A buzzer sounds and the back door automatically opens and closes.

Pressing the switch while the back door is opening/closing stops the operation. When the switch is pressed again for 1 second during the halted operation, the back door will perform the reverse operation.

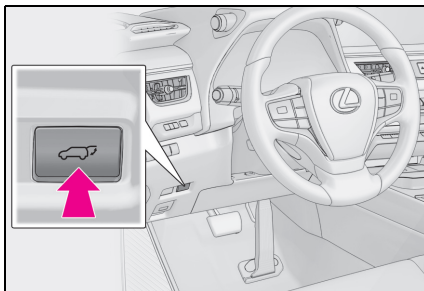

■ Opening/closing the back door from the outside

● Open

When the back door is unlocked: Press the back door opener switch.

When the back door is locked (vehicles with smart entry & start system [vehicles with entry function]): While carrying the electronic key on your person, press the back door opener switch.

A buzzer sounds and the back door automatically opens.

Pressing the switch while the back door is opening stops the operation.

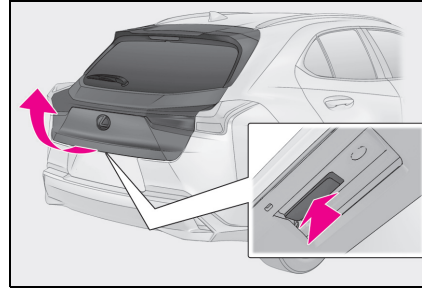

● Close

Press the switch.

A buzzer sounds and the back door automatically closes.

Pressing the switch while the back door is closing stops the operation.

Pressing the switch again will open the back door automatically.

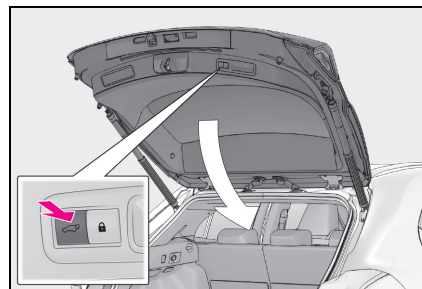

● Close the back door and lock all doors (close & lock function)

Press the switch.

A different buzzer than the normal one will sound and the power back door will begin closing automatically. When the power back door is closed, all of the doors will lock simultaneously and operation signals will indicate that all of the doors have been locked.

If the switch is pressed while the power back door is closing, the operation will stop.

Pressing the switch again will close the power back door automatically.

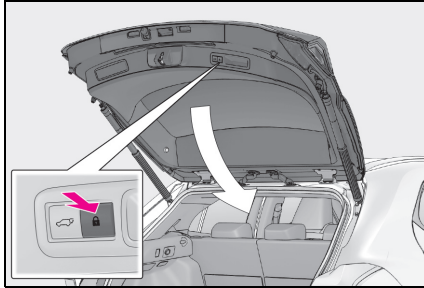

■ Closing the back door using the back door handle

Lower the back door using the back door handle, then a buzzer sounds and the back door automatically closes.

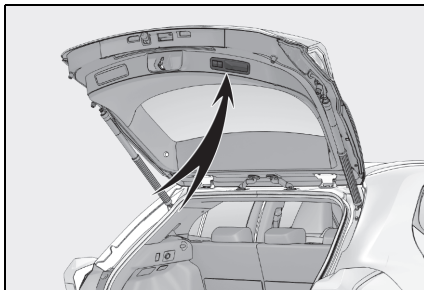

■ Hands Free Power Back Door

- 1 While carrying an electronic key, stand within the smart entry & start system operation range, approximately 50 to 70 cm (19.7 to 27.6 in.) from the rear bumper.

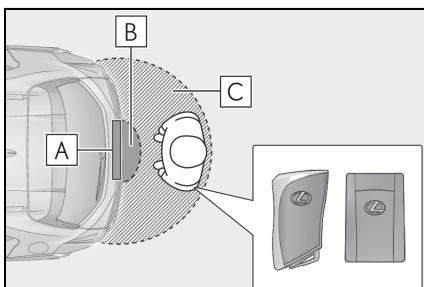

A Hands Free Power Back Door sensor

B Hands Free Power Back Door operation detection area

C Smart entry & start system operation detection area (→P.152)

- 2 Perform a kick operation by moving your foot to within approximately 10 cm (3.9 in.) of the rear bumper and then pulling it back.

- Perform the entire kick operation within 1 second.
- The Hands Free Power Back Door will not start operating while a foot is detected under the rear bumper.
- Operate the Hands Free Power Back Door without contacting the rear bumper with your foot.
- If another electronic key is in the cabin or luggage compartment, it may take slightly longer than normal for the operation to occur.

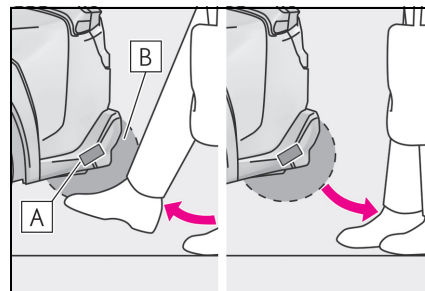

A Hands Free Power Back Door sensor

B Hands Free Power Back Door operation detection area

- 3 When the sensor detects that your foot is pulled back, a buzzer will

sound and the back door will automatically fully open/close.

If a foot is moved under the rear bumper while the back door is opening, the back door will stop moving.

If a foot is moved under the rear bumper while the back door is closing, the back door will open.

■ Luggage compartment light

- The luggage compartment light turns on when the back door is opened.
- If the luggage compartment light is left on when the engine switch is turned off, the light will go off automatically after 20 minutes.

■ Power back door operating conditions

With the power back door operations set to ON, it can automatically open and close for the following conditions:

- The power back door is unlocked. However, the power back door will operate if it is locked, in the following situations:
 - When an electronic key is being carried and the back door opener switch is pressed
 - When opening of the power back door using the wireless remote control when it is locked is enabled by a customized setting.
- When the engine switch is in ON during opening operations, the back door unlocks and operates for any of the following conditions:
 - Parking brake is engaged
 - The brake pedal is depressed
 - The shift lever is in P

■ Hands Free Power Back Door operating conditions

- When the Hands Free Power Back Door (kick sensor) operation setting is turned on
- When an electronic key is carried within the operation range

■ Back door closer

In the event that the back door is left slightly

open, the back door closer will automatically close it to the fully closed position. Whatever the state of the engine switch, the back door closer operates.

■ Operation of the power back door

- A buzzer sounds to indicate that the back door is opening/closing.
- When the power back door operations are OFF, the power back door does not operate but it can be opened and closed by hand.
- When the power back door automatically opens, if an abnormality due to people or objects is detected, operation will stop.

■ Back door reserve lock function

This function reserves locking of all doors beforehand, when the power back door is open.

When the following procedure is performed, all the doors except the power back door are locked and then power back door will also be locked at the same time it is closed.

- 1 Close all doors, except the back door.
- 2 During the power back door closing operation, lock the doors using the smart entry & start system (→P.140) or the wireless remote control. (→P.132)

A buzzer sounds and the emergency flashers flash to indicate that all the doors have been closed and locked.

Before leaving the vehicle, make sure that all the doors are closed and locked. The doors may not be locked due to the jam protection function or door lock prevention function.

■ Close & lock function

When the power back door is open, this function closes the power back door and then locks all of the doors simultaneously.

When the following procedures are performed and there are no electronic keys for the vehicle within the vehicle, all of the doors will lock when the power back door is completely closed.



- 1 Close all of the doors except the power back door.
- 2 While carrying an electronic key, press the  switch on the lower part of the power back door (→P.142).

A different buzzer than the normal one will sound and then the power back door will begin closing automatically. When the power back door is closed, all of the doors will lock simultaneously and operation signals will indicate that all of the doors have been locked.

The double locking system will not operate at this time.

■ Situations in which the close & lock function may not operate properly

In the following situations, the close & lock function may not operate properly:

- If the  switch on the lower part of the power back door (→P.142) is pressed by a hand which is holding an electronic key
- If the  switch on the lower part of the power back door (→P.142) is pressed when the electronic key is in a bag, etc. that is placed on the ground
- If the  switch on the lower part of the power back door (→P.142) is pressed with the electronic key not near the vehicle.

■ Situations in which the Hands Free Power Back Door may not operate properly (if equipped)

In the following situations, the Hands Free Power Back Door may not operate properly:

- When a foot remains under the rear bumper
- If the rear bumper is strongly hit with a foot or is touched for a while
If the rear bumper has been touched for a while, wait for a short time before attempting to operate the Hands Free Power Back Door again.

- When operated while a person is too close to the rear bumper
- When an external radio wave source interferes with the communication between the electronic key and the vehicle (→P.153)
- When the vehicle is parked near an electrical noise source which affects the sensitivity of the Hands Free Power Back Door, such as a pay parking spot, gas station, electrically heated road, or fluorescent light
- When the vehicle is near a TV tower, electric power plant, radio station, large display, airport or other facility that generates strong radio waves or electrical noise
- When a large amount of water is applied to the rear bumper, such as when the vehicle is being washed or in heavy rain
- When mud, snow, ice, etc. is attached to the rear bumper
- When the vehicle has been parked for a while near objects that may move and contact the rear bumper, such as plants
- When an accessory is installed to the rear bumper
If an accessory has been installed, turn the Hands Free Power Back Door (kick sensor) operation setting off.

■ Preventing unintentional operation of the Hands Free Power Back Door (if equipped)

When an electronic key is in the operation range, the Hands Free Power Back Door may operate unintentionally, so be careful in the following situations.

- When a large amount of water is applied to the rear bumper, such as when the vehicle is being washed or in heavy rain
- When dirt is wiped off the rear bumper
- When a small animal or small object, such as a ball, moves under the rear bumper
- When an object is moved from under the rear bumper
- If someone is swinging their legs while sitting on the rear bumper

- If the legs or another part of someone's body contacts the rear bumper while passing by the vehicle
- When the vehicle is parked near an electrical noise source which affects the sensitivity of the Hands Free Power Back Door, such as a pay parking spot, gas station, electrically heated road, or fluorescent light
- When the vehicle is near a TV tower, electric power plant, radio station, large display, airport or other facility that generates strong radio waves or electrical noise
- When the vehicle is parked in a place where objects such as plants are near the rear bumper
- If luggage, etc. is set near the rear bumper
- If accessories or a vehicle cover is installed/removed near the rear bumper
- When the vehicle is being towed

To prevent unintentional operation, turn the Hands Free Power Back Door (kick sensor) operation setting off.

■ When reconnecting the battery

To enable the power back door to operate properly, close the back door manually.

■ Jam protection function

Sensors are installed in the right and left sides of the power back door. When the door is automatically closing and the sensors are pushed due to an object being clamped, etc., the jam protection function operates.

From that position the door automatically moves a little in the opposite direction and then the function stops.

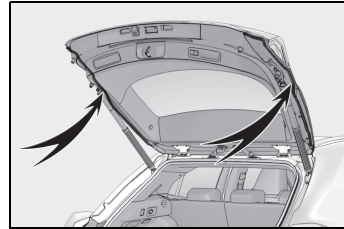

■ If the back door opener is inoperative

The back door can be unlocked from the inside.

1 Remove the cover.

To protect the cover, place a rag between the flathead screwdriver and the cover as shown in the illustration.

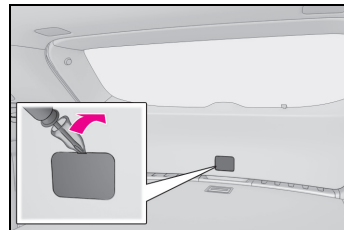

2 Move the lever.

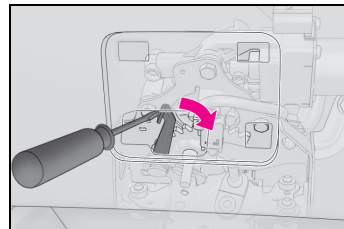

■ Customization

Some functions can be customized. (Customizable features: →P.505)

WARNING

■ Back door closer

- In the event that the back door is left slightly open, the back door closer will automatically close it to the fully closed position. It takes several seconds before the back door closer begins to operate. Be careful not to catch fingers or anything else in the back door, as this may cause bone fractures or other serious injuries.

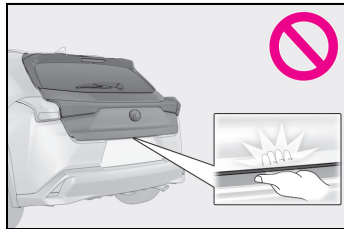

- Be careful not to catch fingers or anything else when using the back door closer as it still operates when the power back door system is canceled.

■ Power back door

Observe the following precautions when operating the power back door. Failure to do so may cause death or serious injury.

- Check the safety of the surrounding area to make sure there are no obstacles or anything that could cause any of your belongings to get caught.
- If anyone is in the vicinity, make sure they are safe and let them know that the back door is about to open or close.
- If the power back door system is disabled, while the back door is operating automatically, the automatic operation is stopped. The back door then has to be operated manually. Take extra care in this situation, as the back door may open or close suddenly.

- If the operating conditions of the power back door (→P.144) are no longer met, a buzzer may sound and the back door may stop opening or closing. The back door then has to be operated manually. Take extra care when on an incline, as the back door may open or close abruptly.

- On an incline, the back door may suddenly shut after it opens. Make sure the back door is fully open and secure.

- In the following situations, the power back door may detect an abnormality and automatic operation may be stopped. In this case, the back door has to be operated manually. Take extra care in this situation, as the back door may open or close suddenly.

- When the back door contacts an obstacle
- When the battery voltage suddenly drops, such as when the engine switch is turned to ON or the engine is started during automatic operation

- If a bicycle carrier or similar heavy object is attached to the back door, the power back door may not operate, causing itself to malfunction, or the back door may suddenly shut again after being opened, causing someone's hands, head or neck to be caught and injured. When installing an accessory part to the back door, ask any authorized Lexus retailer or Lexus authorized repairer, or any reliable repairer for details.

■ Jam protection function

Observe the following precautions. Failure to do so may cause death or serious injury.

- Never use any part of your body to intentionally activate the jam protection function.

WARNING

- The jam protection function may not work if something gets caught just before the back door fully closes. Be careful not to catch fingers caught or anything else.
 - The jam protection function may not work depending on the shape of the object that is caught. Be careful not to catch fingers or anything else.
- **Hands Free Power Back Door**
Observe the following precautions. Failure to do so may cause death or serious injury.
- Check the safety of the surrounding area to make sure there are no obstacles or anything that could cause any of your belongings to get caught.
 - Exhaust gases cause the exhaust pipes to become quite hot. When operating the Hands Free Power Back Door, be careful not to touch the exhaust pipe.
 - Do not operate the Hands Free Power Back Door if there is little space under the rear bumper.

NOTICE

■ Back door spindles

The back door is equipped with spindles **A** that hold the back door in place. Observe the following precautions. Failure to do so may cause damage to the back door spindle **A**, resulting in malfunction.

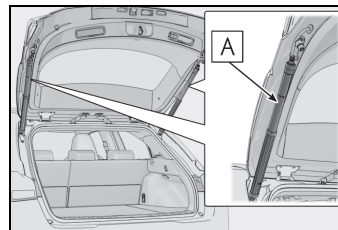

- Do not attach any foreign objects, such as stickers, plastic sheets, or adhesives to the spindle rod.
 - Do not touch the spindle rod with gloves or other fabric items.
 - Do not attach any accessories other than genuine Lexus parts to the power back door.
 - Do not place your hand on the spindle or apply lateral forces to it.
- **To prevent back door closer malfunction**
Do not apply excessive force to the back door while the back door closer is operating. Applying excessive force may cause the back door closer to malfunction.
- **To prevent damage to the power back door**
- Make sure that there is no ice between the back door and frame that would prevent movement of the back door. Operating the power back door when excessive load is present on the back door may cause a malfunction.

**NOTICE**

- Do not apply excessive force to the back door while the power back door is operating.
- Take care not to damage the sensors (installed on the right and left edges of the power back door) (→P.146) with a knife or other sharp object. If the sensor is disconnected, the power back door will not close automatically.

Close & lock function

When closing the power back door using the close & lock function, a different buzzer than the normal one will sound before the operation begins.

To check that the operation has started correctly, check that a different buzzer than the normal one has sounded.

Additionally, when the power back door is fully closed and locked, operation signals will indicate that all of the doors have been locked.

Before leaving the vehicle, make sure that the operation signals have operated and that all of the doors are locked.

Hands Free Power Back Door precautions

Observe the following to ensure that the power back door function operates properly:

- Do not apply coatings that have a rain clearing (hydrophilic) effect, or other coatings, to the lower center part of the rear bumper.

- Do not subject the rear bumper to a strong impact.
If the rear bumper has been subjected to a strong impact, the Hands Free Power Back Door may not operate properly. If the Hands Free Power Back Door does not operate in the following situations, have the vehicle inspected by any authorized Lexus retailer or Lexus authorized repairer, or any reliable repairer.
 - The Hands Free Power Back Door sensor or its surrounding area has been subjected to a strong impact.
 - The lower center part of the rear bumper is scratched or damaged.
- Do not disassemble the rear bumper.
- Do not attach stickers to the rear bumper.
- Do not paint the rear bumper.

Canceling the power back door system (vehicles with power back door)

The power back door system can be enabled/disabled on the multi-information display. (→P.115)



- 1 Press or of the meter control switches and select
- 2 Press or of the meter control switches, select the "Vehicle Settings" and then press "OK".
- 3 Press or of the meter control switches, select and then press "OK".
- 4 Press or of the meter control switches, and then select "System Settings".

- 5 ON and OFF will be switched over with presses of "OK" on the meter control switches.

If the power back door is disabled, it will remain disabled unless it is enabled on the multi-information display. (It will not be enabled even when the engine switch is turned off and then back to ON.)

Canceling the Hands Free Power Back Door (vehicles with power back door)

The Hands Free Power Back Door (kick sensor) can be enabled/disabled on the multi-information display. (→P.115)

- 1 Press **<** or **>** of the meter control switches and select .
- 2 Press **▲** or **▼** of the meter control switches, select the "Vehicle Settings" and then press "OK".
- 3 Press **▲** or **▼** of the meter control switches, select  and then press "OK".
- 4 Press **▲** or **▼** of the meter control switches, and then select "KICK SENSOR".
- 5 ON and OFF will be switched over with presses of "OK" on the meter control switches.

If the Hands Free Power Back Door is disabled, it will remain disabled unless it is enabled on the multi-information display. (It will not be enabled even when the engine switch is turned off and then back to ON.)

Adjusting the open position of the back door (vehicles with power back door)

The open position of the power back door can be adjusted.

- 1 Stop the back door in the desirable position. (→P.141)
- 2 Press and hold the power back door switch on the back door for 2 seconds.
 - When the settings are completed, the buzzer sounds 4 times.
 - When opening the back door the next time, the back door will stop at that position.

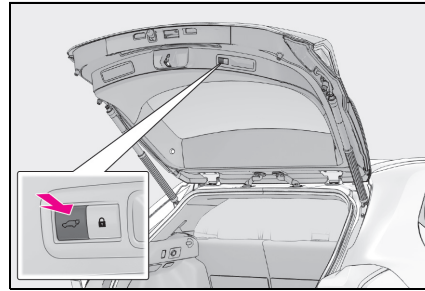

Returning the back door automatic stop position to the initial settings

Press and hold the power back door switch on the back door for 7 seconds.

After the buzzer sounds 4 times, it sounds twice more. When the power back door does the opening operation the next time, the door will open to the initial settings position.

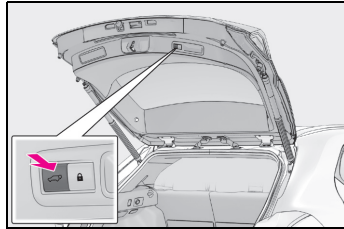

■ Customization

The opening position can be set with the navigation system or multimedia system. (→P.505)

Priority for the stop position is given to the last position set by either the  switch, navigation system or multimedia system.

Smart entry & start system

The following operations can be performed simply by carrying the electronic key (including the card key) on your person, for example in your pocket. The driver should always carry the electronic key.

- Locks and unlocks the doors (vehicles with entry function) (→P.134)
- Locks and unlocks the back door (vehicles with entry function) (→P.140)
- Starts the engine (→P.217)

3

Before driving

■ Antenna location

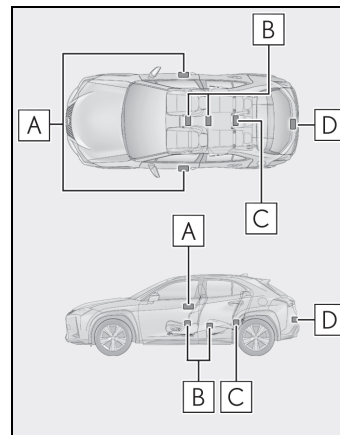

- A** Antennas outside the cabin (vehicles with entry function)
- B** Antennas inside the cabin
- C** Antenna inside the luggage compartment
- D** Antenna outside the luggage compart-

ment (vehicles with entry function)

■ **Effective range (areas within which the electronic key is detected)**

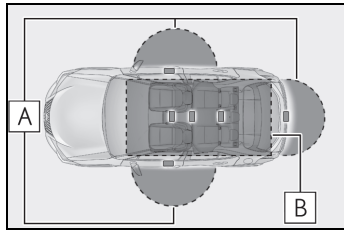

A When locking or unlocking the doors (vehicles with entry function)

The system can be operated when the electronic key is within about 0.7 m (2.3 ft.) of an outside front door handle. (Only the doors detecting the key can be operated.)

B When starting the engine or changing engine switch modes

The system can be operated when the electronic key is inside the vehicle.

■ **If an alarm sounds or a warning message is displayed**

An alarm sounds and warning messages are displayed on the multi-information display to protect against unexpected accidents or theft of the vehicle resulting from erroneous operation. When a warning message is displayed, take appropriate measures based on the displayed message.

When only an alarm sounds, circumstances and correction procedures are as follows.

- When an exterior alarm sounds once for 5 seconds (vehicles with entry function)

Situation	Correction procedure
An attempt was made to lock the vehicle while a door was open.	Close all of the doors and lock the doors again.

- When an interior alarm pings repeatedly

Situation	Correction procedure
The engine switch was turned to ACC while the driver's door was open (The driver's door was opened when the engine switch was in ACC).	Turn the engine switch off and close the driver's door.
The engine switch was turned off while the driver's door was open.	Close the driver's door.

■ **If "Key Detected in Vehicle" is shown on the multi-information display**

An attempt was made to lock the doors using the smart entry & start system while the electronic key was still inside the vehicle. Retrieve the electronic key from the vehicle and lock the doors again.



■ **Battery-saving function (vehicles with entry function)**

The battery-saving function will be activated in order to prevent the electronic key battery and the battery from being discharged while the vehicle is not in operation for a long time.

- In the following situations, the smart entry & start system may take some time to unlock the doors.
 - The electronic key has been left in an area of approximately 2 m (6 ft.) of the outside of the vehicle for 10 minutes or longer.
 - The smart entry & start system has not been used for 5 days or longer.
- If the smart entry & start system has not been used for 14 days or longer, the doors cannot be unlocked at any doors except the driver's door. In this case, take hold of the driver's door handle, or use the wireless remote control or the mechanical key, to unlock the doors.

■ Turning an electronic key to battery-saving mode

- When battery-saving mode is set, battery depletion is minimized by stopping the electronic key from receiving radio waves.

Press  twice while pressing and holding .

Confirm that the electronic key indicator flashes 4 times.

While the battery-saving mode is set, the smart entry & start system cannot be used. To cancel the function, press any of the electronic key buttons.

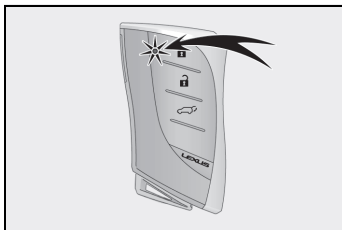

- Electronic keys that will not be used for long periods of time can be set to the battery-saving mode in advance.

■ Conditions affecting operation

The smart entry & start system use weak radio waves. In the following situations, the communication between the electronic key and the vehicle may be affected, preventing the smart entry & start system, wireless remote control and engine immobilizer system from operating properly. (Ways of coping: →P.480)

- When the electronic key battery is depleted
- Near a TV tower, electric power plant, gas station, radio station, large display, airport or other facility that generates strong radio waves or electrical noise
- When carrying a portable radio, cellular phone, cordless phone or other wireless communication device
- When the electronic key is in contact with, or is covered by the following metal-

- lic objects
- Cards to which aluminum foil is attached
- Cigarette boxes that have aluminum foil inside
- Metallic wallets or bags
- Coins
- Hand warmers made of metal
- Media such as CDs and DVDs
- When other wireless keys (that emit radio waves) are being used nearby
- When carrying the electronic key together with the following devices that emit radio waves
- Another vehicle's electronic key or a wireless key that emits radio waves
- Personal computers or personal digital assistants (PDAs)
- Digital audio players
- Portable game systems
- If window tint with a metallic content or metallic objects are attached to the rear window
- When the electronic key is placed near a battery charger or electronic devices
- When the vehicle is parked in a pay parking spot where radio waves are emitted.
- **Note for the entry function**
- Even when the electronic key is within the effective range (detection areas), the system may not operate properly in the following cases:
 - The electronic key is too close to the window or outside door handle, near the ground, or in a high place when the doors are locked or unlocked.
 - The electronic key is on the instrument panel, luggage room, floor, or in the door pockets or glove box when the engine is started or engine switch modes are changed.
- Do not leave the electronic key on top of the instrument panel or near the door pockets when exiting the vehicle. Depending on the radio wave reception conditions, it may be detected by the antenna outside the cabin and the door will become lockable from the outside, possibly trapping the electronic key inside the vehicle.

- As long as the electronic key is within the effective range, the doors may be locked or unlocked by anyone. However, only the doors detecting the electronic key can be used to unlock the vehicle.
 - Even if the electronic key is not inside the vehicle, it may be possible to start the engine if the electronic key is near the window.
 - The doors may unlock if a large amount of water splashes on the door handle, such as in the rain or in a car wash when the electronic key is within the effective range. (The doors will automatically be locked after approximately 30 seconds if the doors are not opened and closed.)
 - If the wireless remote control is used to lock the doors when the electronic key is near the vehicle, there is a possibility that the door may not be unlocked by the entry function. (Use the wireless remote control to unlock the doors.)
 - Touching the door lock sensor while wearing gloves may delay or prevent lock operation. Remove the gloves and touch the lock sensor again.
 - If the door handle becomes wet while the electronic key is within the effective range, the door may lock and unlock repeatedly. In that case, follow the following correction procedures to wash the vehicle:
 - Place the electronic key in a location 2 m (6 ft.) or more away from the vehicle. (Take care to ensure that the key is not stolen.)
 - Set the electronic key to battery-saving mode to disable the smart entry & start system. (→P.153)
 - If the electronic key is inside the vehicle and a door handle becomes wet during a car wash, a buzzer may sound outside the vehicle and "Key Detected in Vehicle" may be shown on the multi-information display. To turn off the alarm, lock all the doors.
 - The lock sensor may not work properly if it comes into contact with ice, snow, mud, etc. Clean the lock sensor and attempt to operate it again.
 - A sudden approach to the effective range or door handle may prevent the doors from being unlocked. In this case, return the door handle to the original position and check that the doors unlock before pulling the door handle again.
 - If there is another electronic key in the detection area, it may take slightly longer to unlock the doors after the door handle is gripped.
- **When the vehicle is not driven for extended periods**
- Vehicles with entry function: To prevent theft of the vehicle, do not leave the electronic key within 2 m (6 ft.) of the vehicle.
 - The smart entry & start system can be deactivated in advance.
 - Setting the electronic key to battery-saving mode helps to reduce key battery depletion. (→P.153)
- **To operate the system properly**
- Make sure to carry the electronic key when operating the system. Do not get the electronic key too close to the vehicle when operating the system from the outside of the vehicle.
- Depending on the position and holding condition of the electronic key, the key may not be detected correctly and the system may not operate properly. (The alarm may go off accidentally, or the door lock prevention may not operate.)
- **If the smart entry & start system does not operate properly**
- Locking and unlocking the doors: Use the mechanical key. (→P.480)
 - Starting the engine: →P.481
- **Customization**
- Settings (e.g. smart entry & start system) can be changed. (Customizable features: →P.505)
- If the smart entry & start system has been deactivated by a customized setting, refer to the explanations for the following operations.
- Locking and unlocking the doors:

Use the wireless remote control or mechanical key. (→P.134, 480)

- Starting the engine and changing engine switch modes: →P.481
- Stopping the engine: →P.218

■ Certification for the smart entry & start system

Hereby, TOYOTA MOTOR CORPORATION declares that the radio equipment type TMLF15-1 is in compliance with Directive 2014/53/EU.

The full text of the EU declaration of conformity is available at the following internet address:

<http://my.lexus.eu>

Frequency band: 119 - 135 kHz

Maximum radio-frequency power: 55dB μ A/m @10m

TOYOTA MOTOR CORPORATION vakuuttaa, että radiolaitetyyppi TMLF15-1 on direktiivin 2014/53/EU mukainen.

EU-vaatimustenmukaisuusvakuutuksen täysimittainen teksti on saatavilla seuraavassa internetosoitteessa:

<http://my.lexus.eu>

Radiotaajuus: 119 - 135 kHz

suurin mahdollinen lähetysteho: 55dB μ A/m @10m

Hierbij verklaar ik, TOYOTA MOTOR CORPORATION, dat het type radioapparatuur TMLF15-1 conform is met Richtlijn 2014/53/EU.

De volledige tekst van de EU-conformiteitsverklaring kan worden geraadpleegd op het volgende internetadres:

<http://my.lexus.eu>

Frequentieband: 119 - 135 kHz

Maximaal radiofrequentievermogen: 55dB μ A/m @10m

Le soussigné, TOYOTA MOTOR CORPORATION, déclare que l'équipement radioélectrique du type TMLF15-1 est conforme à la directive 2014/53/UE.

Le texte complet de la déclaration UE de conformité est disponible à l'adresse internet suivante:

<http://my.lexus.eu>

Bande de fréquences: 119 - 135 kHz

Puissance de radiofréquence maximale: 55dB μ A/m @10m

Härmed försäkrar TOYOTA MOTOR CORPORATION att denna typ av radioutrustning TMLF15-1 överensstämmer med direktiv 2014/53/EU.

Den fullständiga texten till EU-försäkran om överensstämmelse finns på följande webbadress:

<http://my.lexus.eu>

Frekvensband: 119 - 135 kHz

Maximal radiofrekvensseffekt: 55dB μ A/m @10m

Hermed erklærer TOYOTA MOTOR CORPORATION, at radioudstyrstypen TMLF15-1 er i overensstemmelse med direktiv 2014/53/EU.

EU-overensstemmelseserklæringens fulde tekst kan findes på følgende internetadresse:

<http://my.lexus.eu>

Frekvensbånd: 119 - 135 kHz

Maksimal radiofrekvensseffekt: 55dB μ A/m @10m

Hiermit erklärt TOYOTA MOTOR CORPORATION, dass der Funkanlagentyp TMLF15-1 der Richtlinie 2014/53/EU entspricht.

Der vollständige Text der EU-Konformitätserklärung ist unter der folgenden Internetadresse verfügbar:

<http://my.lexus.eu>

Frequenzband: 119 - 135 kHz

Abgestrahlte maximale Sendeleistung: 55dBμA/m @10m

Με την παρούσα ο/η TOYOTA MOTOR CORPORATION, δηλώνει ότι ο ραδιοεξοπλισμός TMLF15-1 πληροί την οδηγία 2014/53/ΕΕ.

Το πλήρες κείμενο της δήλωσης συμμόρφωσης ΕΕ διατίθεται στην ακόλουθη ιστοσελίδα στο διαδίκτυο:

<http://my.lexus.eu>

Ζώνη συχνοτήτων: 119 - 135 kHz

Μέγιστη ισχύς ραδιοσυχνότητας: 55dBμA/m @10m

Il fabbricante, TOYOTA MOTOR CORPORATION, dichiara che il tipo di apparecchiatura radio TMLF15-1 è conforme alla direttiva 2014/53/UE.

Il testo completo della dichiarazione di conformità UE è disponibile al seguente indirizzo Internet:

<http://my.lexus.eu>

Banda di frequenza: 119 - 135 kHz

Potenza massima radiofrequenza: 55dBμA/m @10m

Por la presente, TOYOTA MOTOR CORPORATION declara que el tipo de equipo radioeléctrico TMLF15-1 es conforme con la Directiva 2014/53/UE.

El texto completo de la declaración UE de conformidad está disponible en la dirección Internet siguiente:

<http://my.lexus.eu>

Banda de frecuencia: 119 - 135 kHz

Potencia máxima de radiofrecuencia: 55dB μ A/m @10m

O(a) abaixo assinado(a) TOYOTA MOTOR CORPORATION declara que o presente tipo de equipamento de rádio TMLF15-1 está em conformidade com a Diretiva 2014/53/UE.

O texto integral da declaração de conformidade está disponível no seguinte endereço de Internet:

<http://my.lexus.eu>

Banda de frequência: 119 - 135 kHz

Potência máxima de radiofrequências: 55dB μ A/m @10m

B'dan, TOYOTA MOTOR CORPORATION, niddikjara li dan it-tip ta' tagħmir tar-radju TMLF15-1 huwa konformi mad-Direttiva 2014/53/UE.

It-test kollu tad-dikjarazzjoni ta' konformità tal-UE huwa disponibbli f'dan l-indirizz tal-Internet li ġej:

<http://my.lexus.eu>

Tíðnisvið: 119 - 135 kHz

Hámarks útvarpsbylgjutíðni: 55dB μ A/m @10m

Käesolevaga deklareerib TOYOTA MOTOR CORPORATION, et käesolev raadioseadme tüüp TMLF15-1 vastab direktiivi 2014/53/EL nõuetele.

ELi vastavusdeklaratsiooni täielik tekst on kättesaadav järgmisel internetiaadressil:

<http://my.lexus.eu>

Sagedusriba: 119 - 135 kHz

Maksimaalne saatevõimsus: 55dB μ A/m @10m

TOYOTA MOTOR CORPORATION igazolja, hogy a TMLF15-1 típusú rádióberendezés megfelel a 2014/53/EU irányelvnek.

Az EU-megfelelőségi nyilatkozat teljes szövege elérhető a következő internetes címen:

<http://my.lexus.eu>

Frekvenciasáv: 119 - 135 kHz

Maximális jelerősség: 55dB μ A/m @10m

TOYOTA MOTOR CORPORATION týmto vyhlasuje, že rádiové zariadenie typu TMLF15-1 je v súlade so smernicou 2014/53/EÚ.

Úplné EÚ vyhlásenie o zhode je k dispozícii na tejto internetovej adrese:

<http://my.lexus.eu>

Frekvenčné pásmo: 119 - 135 kHz

Maximálny rádiový výkon: 55dB μ A/m @10m

Tímto TOYOTA MOTOR CORPORATION prohlašuje, že typ rádiového zařízení TMLF15-1 je v souladu se směrnicí 2014/53/EU.

Úplné znění EU prohlášení o shodě je k dispozici na této internetové adrese:

<http://my.lexus.eu>

Kmitočtové pásmo: 119 - 135 kHz

Maximální radiofrekvenční výkon: 55dB μ A/m @10m

TOYOTA MOTOR CORPORATION potvrdzuje, da je tip radijske opreme TMLF15-1 skladen z Direktivo 2014/53/EU.

Celotno besedilo izjave EU o skladnosti je na voljo na naslednjem spletnem naslovu:

<http://my.lexus.eu>

Frekvenčni pas: 119 - 135 kHz

Največja moč radijske frekvence: 55dB μ A/m @10m

Aš, TOYOTA MOTOR CORPORATION, patvirtinu, kad radijo įrenginių tipas TMLF15-1 atitinka Direktyvą 2014/53/ES.

Visas ES atitikties deklaracijos tekstas prieinamas šiuo interneto adresu:

<http://my.lexus.eu>

Dažnių juosta: 119 - 135 kHz

Didžiausia radijo dažnių galia: 55dB μ A/m @10m

Ar šo TOYOTA MOTOR CORPORATION deklarē, ka radioiekārta TMLF15-1 atbilst Direktīvai 2014/53/ES.

Pilns ES atbilstības deklarācijas teksts ir pieejams šādā interneta vietnē:

<http://my.lexus.eu>

Frekvenču josla: 119 - 135 kHz

Maksimālā radiofrekvenču jauda: 55dB μ A/m @10m

TOYOTA MOTOR CORPORATION niniejszym oświadcza, że typ urządzenia radiowego TMLF15-1 jest zgodny z dyrektywą 2014/53/UE.

Pełny tekst deklaracji zgodności UE jest dostępny pod następującym adresem internetowym:

<http://my.lexus.eu>

Zakres częstotliwości: 119 - 135 kHz

Maksymalna moc częstotliwości radiowej: 55dB μ A/m @10m

TOYOTA MOTOR CORPORATION lýsir því hér með yfir að fjarskiptatækið af gerð TMLF15-1 er í samræmi við tilskipun 2014/53/EU.

Öll ESB-samræmisýfirlýsingin er tiltæk á eftirfarandi vefslóð:

<http://my.lexus.eu>

Tíðnisvið: 119 - 135 kHz

Hámarks útværpsbylgjutíðni: 55dB μ A/m @10m

TOYOTA MOTOR CORPORATION erklærer herved at radioustyrtyperen TMLF15-1 er i samsvar med direktivet 2014/53/EU.

Hele teksten av EU-samsvarserklæringen kan leses på det følgende nettstedet:

<http://my.lexus.eu>

Frekvensbånd: 119 - 135 kHz

Maksimal radiofrekvenseffekt: 55dB μ A/m @10m

С настоящото TOYOTA MOTOR CORPORATION декларира, че този тип радиосъоръжение TMLF15-1 е в съответствие с Директива 2014/53/ЕС.

Цялостният текст на ЕС декларацията за съответствие може да се намери на следния интернет адрес:

<http://my.lexus.eu>

Радиочестотна лента: 119 - 135 kHz

Максимална радиочестотна мощност: 55dB μ A/m @10m

Prin prezenta, TOYOTA MOTOR CORPORATION declară că tipul de echipamente radio TMLF15-1 este în conformitate cu Directiva 2014/53/UE.

Textul integral al declarației UE de conformitate este disponibil la următoarea adresă internet:

<http://my.lexus.eu>

Banda de frecvență: 119 - 135 kHz

Puterea maximă de radiofrecvență: 55dB μ A/m @10m

Ovime TOYOTA MOTOR CORPORATION potvrđuje da je radio-oprema tipa TMLF15-1 u skladu sa Direktivom 2014/53/EU.

Potpuni tekst EU deklaracije o usaglašenosti dostupan je na slijedećoj internet adresi:

<http://my.lexus.eu>

Frekvencijski opseg: 119 - 135 kHz

Maksimalna radio-frekvencijska snaga: 55dB μ A/m @10m

Me anë të këtij dokumenti, TOYOTA MOTOR CORPORATION deklararon se tipi i radiopajisjes TMLF15-1 është në përputhje me Direktivën 2014/53/EU.

Teksti i plotë i deklaratës së konformitetit të Bashkimit Evropian është i disponueshëm në adresën e mëposhtme të internetit:

<http://my.lexus.eu>

Brezi i frekuencës: 119 - 135 kHz

Fuqia maksimale e radiofrekuencës: 55dB μ A/m @10m

TOYOTA MOTOR CORPORATION ovime izjavljuje da je radijska oprema tipa TMLF15-1 u skladu s Direktivom 2014/53/EU.

Cjeloviti tekst EU izjave o sukladnosti dostupan je na sljedećoj internetskoj adresi:

<http://my.lexus.eu>

Frekvencijski pojas: 119 - 135 kHz

Maksimalna RF snaga: 55dB μ A/m @10m

Ovim TOYOTA MOTOR CORPORATION potvrđuje da je radio-oprema tipa TMLF15-1 u skladu sa Direktivom 2014/53/EU.

Potpuni tekst EU deklaracije o usaglašenosti dostupan je na sledećoj internet adresi:

<http://my.lexus.eu>

Frekventni opseg: 119 - 135 kHz

Maksimalna radio-frekventna snaga: 55dB μ A/m @10m

TOYOTA MOTOR CORPORATION, iŝbu belgeyle telsiz cihazı türünün TMLF15-1 2014/53/EU nolu Direktif ile uyumlu olduđunu beyan etmektedir.

AB uygunluk beyanının tam metnine aŝađıdaki internet adresinden ulaŝabilirsiniz:

<http://my.lexus.eu>

Frekans bandı: 119 - 135 kHz

Maksimum radyo frekans gücü: 55dB μ A/m @10m

TOYOTA

TOYOTA MOTOR CORPORATION

1, TOYOTA-CHO, TOYOTA, AICHI, 471-8571, JAPAN TEL: +81-565-28-2121

EU Declaration of Conformity



1. Radio equipment (Product / Type):
Smart LF Oscillator / TMLF15-1
 2. Name and address of the manufacturer:
TOYOTA MOTOR CORPORATION
1, Toyota -cho, Toyota, Aichi, 471-8572, Japan
 3. This declaration of conformity is issued under the sole responsibility of the manufacturer.
 4. Object of the declaration:
TMLF15-1
 5. The object of the declaration described above is in conformity with the relevant Union harmonisation legislation:
Directive 2014/53/EU
 6. References to the relevant harmonised standards used or references to the other technical specifications in relation to which conformity is declared:

(Health & safety requirements)	EN 60950-1:2006 + Amd.11:2009 + Amd.1:2010 + Amd.12:2011 + Amd.2:2013
(EMC requirements)	EN 301 489-1 V1.9.2 & EN 301 489-3 V1.6.1
(Effective uses of radio spectrum)	EN 300 330 V2.1.1
 7. The notified body:
Not Applicable
 8. Accessories and components, including software, which allow the radio equipment to operate as intended and covered by the EU declaration of conformity:
Not Applicable
 9. Additional information:
None
- Place and date of issue Japan, April 10, 2017
- Signature Tomoo Kakegawa
Tomoo Kakegawa
General Manager
- Function _____

Receiver:	Model: 23ABB
Transmitter:	Model: 14CCG
	Operation frequency: 433.58/434.42 MHz
	Maximum output power(ERP): 0.01 mW
Manufacturer:	DENSO CORPORATION
Address:	1-1, Showa-cho, Kariya-shi, Aichi-ken, 448-8661 Japan
NOTE:	-Dispose of used batteries according to the local laws. -Replace only with the same or equivalent type recommended by the manufacturer.
<p>Hereby, DENSO CORPORATION declares that the radio equipment type 23ABB/14CCG is in compliance with Directive 2014/53/EU.</p> <p>The full text of the EU declaration of conformity is available at the following internet address: https://www.denso.co.jp/en/contactus/form/doc/index.html</p>	
<p>DENSO CORPORATION vakuuttaa, että radiolaitetyyppi 23ABB/14CCG on direktiivin 2014/53/EU mukainen.</p> <p>EU-vaatimustenmukaisuusvakuutuksen täysimittainen teksti on saatavilla seuraavassa internetosoitteessa: https://www.denso.co.jp/en/contactus/form/doc/index.html</p>	

<p>Hierbij verklaar ik, DENSO CORPORATION, dat het type radioapparatuur 23ABB/14CCG conform is met Richtlijn 2014/53/EU.</p> <p>De volledige tekst van de EU-conformiteitsverklaring kan worden geraadpleegd op het volgende internetadres: https://www.denso.co.jp/en/contactus/form/doc/index.html</p>	03
<p>Le soussigné, DENSO CORPORATION, déclare que l'équipement radioélectrique du type 23ABB/14CCG est conforme à la directive 2014/53/UE.</p> <p>Le texte complet de la déclaration UE de conformité est disponible à l'adresse internet suivante: https://www.denso.co.jp/en/contactus/form/doc/index.html</p>	04
<p>Härmed försäkrar DENSO CORPORATION att denna typ av radioutrustning 23ABB/14CCG överensstämmer med direktiv 2014/53/EU.</p> <p>Den fullständiga texten till EU-försäkran om överensstämmelse finns på följande webbadress: https://www.denso.co.jp/en/contactus/form/doc/index.html</p>	05
<p>Hermed erklærer DENSO CORPORATION, at radioudstyrstypen 23ABB/14CCG er i overensstemmelse med direktiv 2014/53/EU.</p> <p>EU-overensstemmelseserklæringens fulde tekst kan findes på følgende internetadresse: https://www.denso.co.jp/en/contactus/form/doc/index.html</p>	06
<p>Hiermit erkläre DENSO CORPORATION, dass der Funkanlagentyp 23ABB/14CCG der Richtlinie 2014/53/EU entspricht.</p> <p>Der vollständige Text der EU-Konformitätserklärung ist unter der folgenden Internetadresse verfügbar: https://www.denso.co.jp/en/contactus/form/doc/index.html</p>	07

<p>Με την παρούσα ο/η DENSO CORPORATION, δηλώνει ότι ο ραδιοεξοπλισμός 23ABB/14CCG πληροί την οδηγία 2014/53/EE.</p> <p>Το πλήρες κείμενο της δήλωσης συμμόρφωσης ΕΕ διατίθεται στην ακόλουθη ιστοσελίδα στο διαδίκτυο: https://www.denso.co.jp/en/contactus/form/doc/index.html</p>	08
<p>Il fabbricante, DENSO CORPORATION, dichiara che il tipo di apparecchiatura radio 23ABB/14CCG è conforme alla direttiva 2014/53/UE.</p> <p>Il testo completo della dichiarazione di conformità UE è disponibile al seguente indirizzo Internet: https://www.denso.co.jp/en/contactus/form/doc/index.html</p>	09
<p>Por la presente, DENSO CORPORATION declara que el tipo de equipo radioeléctrico 23ABB/14CCG es conforme con la Directiva 2014/53/UE.</p> <p>El texto completo de la declaración UE de conformidad está disponible en la dirección Internet siguiente: https://www.denso.co.jp/en/contactus/form/doc/index.html</p>	10
<p>O(a) abaixo assinado(a) DENSO CORPORATION declara que o presente tipo de equipamento de rádio 23ABB/14CCG está em conformidade com a Diretiva 2014/53/UE.</p> <p>O texto integral da declaração de conformidade está disponível no seguinte endereço de Internet: https://www.denso.co.jp/en/contactus/form/doc/index.html</p>	11
<p>B'dan, DENSO CORPORATION, niddikjara li dan it-tip ta' tagħmir tar-radju 23ABB/14CCG huwa konformi mad-Direttiva 2014/53/UE.</p> <p>It-test kollu tad-dikjarazzjoni ta' konformità tal-UE huwa disponibbli f'dan l-indirizz tal-Internet li ġej: https://www.denso.co.jp/en/contactus/form/doc/index.html</p>	12

<p>Käesolevaga deklareerib DENSO CORPORATION, et käesolev raadioseadme tüüp 23ABB/14CCG vastab direktiivi 2014/53/EL nõuetele.</p> <p>ELi vastavusdeklaratsiooni täielik tekst on kättesaadav järgmisel internetiaadressil: https://www.denso.co.jp/en/contactus/form/doc/index.html</p>	13
<p>DENSO CORPORATION igazolja, hogy a 23ABB/14CCG típusú rádióberendezés megfelel a 2014/53/EU irányelvnek.</p> <p>Az EU-megfelelőségi nyilatkozat teljes szövege elérhető a következő internetes címen: https://www.denso.co.jp/en/contactus/form/doc/index.html</p>	14
<p>DENSO CORPORATION týmto vyhlasuje, že rádiové zariadenie typu 23ABB/14CCG je v súlade so smernicou 2014/53/EÚ.</p> <p>Úplné EÚ vyhlásenie o zhode je k dispozícii na tejto internetovej adrese: https://www.denso.co.jp/en/contactus/form/doc/index.html</p>	15
<p>Tímto DENSO CORPORATION prohlašuje, že typ rádiového zařízení 23ABB/14CCG je v souladu se směrnicí 2014/53/EU.</p> <p>Úplné znění EU prohlášení o shodě je k dispozici na této internetové adrese: https://www.denso.co.jp/en/contactus/form/doc/index.html</p>	16
<p>DENSO CORPORATION potrjuje, da je tip radijske opreme 23ABB/14CCG skladen z Direktivo 2014/53/EU.</p> <p>Celotno besedilo izjave EU o skladnosti je na voljo na naslednjem spletnem naslovu: https://www.denso.co.jp/en/contactus/form/doc/index.html</p>	17

Aš, DENSO CORPORATION, patvirtinu, kad radijo įrenginių tipas 23ABB/14CCG atitinka Direktyvą 2014/53/ES. Visas ES atitikties deklaracijos tekstas prieinamas šiuo interneto adresu: https://www.denso.co.jp/en/contactus/form/doc/index.html	18
Ar šo DENSO CORPORATION deklārē, ka radioiekārta 23ABB/14CCG atbilst Direktīvai 2014/53/ES. Pilns ES atbilstības deklarācijas teksts ir pieejams šādā interneta vietnē: https://www.denso.co.jp/en/contactus/form/doc/index.html	19
DENSO CORPORATION niniejszym oświadcza, że typ urządzenia radiowego 23ABB/14CCG jest zgodny z dyrektywą 2014/53/UE. Pełny tekst deklaracji zgodności UE jest dostępny pod następującym adresem internetowym: https://www.denso.co.jp/en/contactus/form/doc/index.html	20
Hér með lýsir DENSO CORPORATION yfir því að 23ABB/14CCG er í samræmi við grunnkröfur og aðrar kröfur, sem gerðar eru í tilskipun 2014/53/EU. Samræmisýfirlýsing er einnig aðgengileg á eftirfarandi vefslóð: https://www.denso.co.jp/en/contactus/form/doc/index.html	21
DENSO CORPORATION erklærer at 23ABB/14CCG er i overensstemmelse med direktiv 2014/53/EU. Samsvarserklæringen i fulltekst er tilgjengelig på følgende internettsadresse: https://www.denso.co.jp/en/contactus/form/doc/index.html	22

<p>С настоящото DENSO CORPORATION декларира, че този тип радиосъоръжение 23ABB/14CCG е в съответствие с Директива 2014/53/EC.</p> <p>Цялостният текст на ЕС декларацията за съответствие може да се намери на следния интернет адрес: https://www.denso.co.jp/en/contactus/form/doc/index.html</p>	23
<p>Prin prezenta, DENSO CORPORATION declară că tipul de echipamente radio 23ABB/14CCG este în conformitate cu Directiva 2014/53/UE.</p> <p>Textul integral al declarației UE de conformitate este disponibil la următoarea adresă internet: https://www.denso.co.jp/en/contactus/form/doc/index.html</p>	24
<p>DENSO CORPORATION ovime izjavljuje da je radijska oprema tipa 23ABB/14CCG u skladu s Direktivom 2014/53/EU.</p> <p>Cjeloviti tekst EU izjave o sukladnosti dostupan je na sljedećoj internetskoj adresi: https://www.denso.co.jp/en/contactus/form/doc/index.html</p>	25
<p>Ovim, DENSO CORPORATION, izjavljuje da ovaj 23ABB/14CCG je usklađen sa bitnim zahtjevima i drugim relevantnim odredbama Direktive 1999/5/EC.</p>	26
<p>Ovim, DENSO CORPORATION, deklariše da je 23ABB/14CCG u skladu sa osnovnim zahtevima i ostalim relevantnim odredbama Direktive 1999/5/EC.</p>	27
<p>Nepermjet kesaj, DENSO CORPORATION, deklaruj qe ky 23ABB/14CCG eshte ne pajtim me kerkesat thelbesore dhe dispozitat e tjera perkatese te Direktives 1999/5/EC.</p>	28



The latest "DECLARATION of CONFORMITY" (DoC) is available at the following address:
<https://www.denso.co.jp/en/contactus/form/doc/index.html>

Hereby, TOKAI RIKA CO., LTD. declares that the radio equipment type B2C2K2R is in compliance with Directive 2014/53/EU.

The full text of the EU declaration of conformity is available at the following internet address:

<http://www.tokai-rika.co.jp/pc>

Frequency band: 433.050 - 434.790 MHz
Maximum radio-frequency power: 10mW(ERP)

TOKAI RIKA CO., LTD. vakuuttaa, että radiolaitetyyppi B2C2K2R on direktiivin 2014/53/EU mukainen.

EU-vaatimustenmukaisuusvakuutuksen täysimittainen teksti on saatavilla seuraavassa internetosoitteessa:

<http://www.tokai-rika.co.jp/pc>

Radiotaajuus: 433.050 - 434.790 MHz
suurin mahdollinen lähetysteho: 10mW(ERP)

Hierbij verklaar ik, TOKAI RIKA CO., LTD., dat het type radioapparatuur B2C2K2R conform is met Richtlijn 2014/53/EU.

De volledige tekst van de EU-conformiteitsverklaring kan worden geraadpleegd op het volgende internetadres:

<http://www.tokai-rika.co.jp/pc>

Frequentieband: 433.050 - 434.790 MHz
Maximaal radiofrequentievermogen: 10mW(ERP)

Le soussigné, TOKAI RIKA CO., LTD., déclare que l'équipement radioélectrique du type B2C2K2R est conforme à la directive 2014/53/UE.

Le texte complet de la déclaration UE de conformité est disponible à l'adresse internet suivante:

<http://www.tokai-rika.co.jp/pc>

Bande de fréquences: 433.050 - 434.790 MHz

Puissance de radiofréquence maximale: 10mW(ERP)

Härmed försäkrar TOKAI RIKA CO., LTD. att denna typ av radioutrustning B2C2K2R överensstämmer med direktiv 2014/53/EU.

Den fullständiga texten till EU-försäkran om överensstämmelse finns på följande webbadress:

<http://www.tokai-rika.co.jp/pc>

Frekvensband: 433.050 - 434.790 MHz

Maximal radiofrekvensseffekt: 10mW(ERP)

Hermed erklærer TOKAI RIKA CO., LTD., at radioudstyrstypen B2C2K2R er i overensstemmelse med direktiv 2014/53/EU.

EU-overensstemmelseserklæringens fulde tekst kan findes på følgende internetadresse:

<http://www.tokai-rika.co.jp/pc>

Frekvensbånd: 433.050 - 434.790 MHz

Maksimal radiofrekvensseffekt: 10mW(ERP)

Hiermit erklärt TOKAI RIKA CO., LTD., dass der Funkanlagentyp B2C2K2R der Richtlinie 2014/53/EU entspricht.

Der vollständige Text der EU-Konformitätserklärung ist unter der folgenden Internetadresse verfügbar:

<http://www.tokai-rika.co.jp/pc>

Frequenzband: 433.050 - 434.790 MHz

Abgestrahlte maximale Sendeleistung: 10mW(ERP)

Με την παρούσα ο/η TOKAI RIKA CO., LTD., δηλώνει ότι ο ραδιοεξοπλισμός B2C2K2R πληροί την οδηγία 2014/53/ΕΕ.

Το πλήρες κείμενο της δήλωσης συμμόρφωσης ΕΕ διατίθεται στην ακόλουθη ιστοσελίδα στο διαδίκτυο:

<http://www.tokai-rika.co.jp/pc>

Ζώνη συχνότητων: 433.050 - 434.790 MHz

Μέγιστη ισχύς ραδιοσυχνότητας: 10mW(ERP)

Il fabbricante, TOKAI RIKA CO., LTD., dichiara che il tipo di apparecchiatura radio B2C2K2R è conforme alla direttiva 2014/53/UE.

Il testo completo della dichiarazione di conformità UE è disponibile al seguente indirizzo Internet:

<http://www.tokai-rika.co.jp/pc>

Banda di frequenza: 433.050 - 434.790 MHz

Potenza massima radiofrequenza: 10mW(ERP)

Por la presente, TOKAI RIKA CO., LTD. declara que el tipo de equipo radioeléctrico B2C2K2R es conforme con la Directiva 2014/53/UE.

El texto completo de la declaración UE de conformidad está disponible en la dirección Internet siguiente:

<http://www.tokai-rika.co.jp/pc>

Banda de frecuencia: 433.050 - 434.790 MHz

Potencia máxima de radiofrecuencia: 10mW(ERP)

O(a) abaixo assinado(a) TOKAI RIKA CO., LTD. declara que o presente tipo de equipamento de rádio B2C2K2R está em conformidade com a Diretiva 2014/53/UE.

O texto integral da declaração de conformidade está disponível no seguinte endereço de Internet:

<http://www.tokai-rika.co.jp/pc>

Banda de frequência: 433.050 - 434.790 MHz

Potência máxima de radiofrequências: 10mW(ERP)

B'dan, TOKAI RIKA CO., LTD., niddikjara li dan it-tip ta' tagħmir tar-radju B2C2K2R huwa konformi mad-Direttiva 2014/53/UE.

It-test kollu tad-dikjarazzjoni ta' konformità tal-UE huwa disponibbli f'dan l-indirizz tal-Internet li ġej:

<http://www.tokai-rika.co.jp/pc>

Tíðnisvið: 433.050 - 434.790 MHz

Hámarks útværpsbylgjutíðni: 10mW(ERP)

Käesolevaga deklareerib TOKAI RIKA CO., LTD., et käesolev raadioseadme tüüp B2C2K2R vastab direktiivi 2014/53/EL nõuetele.

ELi vastavusdeklaratsiooni täielik tekst on kättesaadav järgmisel internetiaadressil:

<http://www.tokai-rika.co.jp/pc>

Sagedusriba: 433.050 - 434.790 MHz

Maksimaalne saatevõimsus: 10mW(ERP)

TOKAI RIKA CO., LTD. igazolja, hogy a B2C2K2R típusú rádióberendezés megfelel a 2014/53/EU irányelvnek.

Az EU-megfelelőségi nyilatkozat teljes szövege elérhető a következő internetes címen:

<http://www.tokai-rika.co.jp/pc>

Frekvenciasáv: 433.050 - 434.790 MHz

Maximális jelerősség: 10mW(ERP)

TOKAI RIKA CO., LTD. týmto vyhlasuje, že rádiové zariadenie typu B2C2K2R je v súlade so smernicou 2014/53/EÚ.

Úplné EÚ vyhlásenie o zhode je k dispozícii na tejto internetovej adrese:

<http://www.tokai-rika.co.jp/pc>

Frekvenčné pásmo: 433.050 - 434.790 MHz

Maximálny rádiový výkon: 10mW(ERP)

Tímto TOKAI RIKA CO., LTD. prohlašuje, že typ rádiového zařízení B2C2K2R je v souladu se směrnicí 2014/53/EU.

Úplné znění EU prohlášení o shodě je k dispozici na této internetové adrese:

<http://www.tokai-rika.co.jp/pc>

Kmitočtové pásmo: 433.050 - 434.790 MHz
Maximální radiofrekvenční výkon: 10mW(ERP)

TOKAI RIKA CO., LTD. potvrjuje, da je tip radijske opreme B2C2K2R skladen z Direktivo 2014/53/EU.

Celotno besedilo izjave EU o skladnosti je na voljo na naslednjem spletnem naslovu:

<http://www.tokai-rika.co.jp/pc>

Frekvenčni pas: 433.050 - 434.790 MHz
Največja moč radijske frekvence: 10mW(ERP)

Aš, TOKAI RIKA CO., LTD., patvirtinu, kad radijo įrenginių tipas B2C2K2R atitinka Direktyvą 2014/53/ES.

Visas ES atitikties deklaracijos tekstas prieinamas šiuo interneto adresu:

<http://www.tokai-rika.co.jp/pc>

Dažnių juosta: 433.050 - 434.790 MHz
Didžiausia radijo dažnių galia: 10mW(ERP)

Ar šo TOKAI RIKA CO., LTD. deklarē, ka radioiekārta B2C2K2R atbilst Direktīvai 2014/53/ES.

Pilns ES atbilstības deklarācijas teksts ir pieejams šādā interneta vietnē:

<http://www.tokai-rika.co.jp/pc>

Frekvenču josla: 433.050 - 434.790 MHz
Maksimālā radiofrekvenču jauda: 10mW(ERP)

TOKAI RIKA CO., LTD. niniešm ošwiadcza, że typ urządzenia radiowego B2C2K2R jest zgodny z dyrektywą 2014/53/UE.

Pełny tekst deklaracji zgodności UE jest dostępny pod następującym adresem internetowym:

<http://www.tokai-rika.co.jp/pc>

Zakres częstotliwości: 433.050 - 434.790 MHz
Maksymalna moc częstotliwości radiowej: 10mW(ERP)

TOKAI RIKA CO., LTD. lýsir því hér með yfir að fjarskiptatækið af gerð B2C2K2R er í samræmi við tilskipun 2014/53/EU.

Öll ESB-samræmisýfirlýsingin er tiltæk á eftirfarandi vefslóð:

<http://www.tokai-rika.co.jp/pc>

Tíðnisvið: 433.050 - 434.790 MHz
Hámarks útværpsbylgjutíðni: 10mW(ERP)

TOKAI RIKAI CO., LTD. erklærer herved at radioutstyrtypen B2C2K2R er i samsvar med direktivet 2014/53/EU.

Hele teksten av EU-samsvarserklæringen kan leses på det følgende nettstedet:

<http://www.tokai-rika.co.jp/pc>

Frekvensbånd: 433.050 - 434.790 MHz
Maksimal radiofrekvenseffekt: 10mW(ERP)

С настоящото TOKAI RIKAI CO., LTD. декларира, че този тип радиосъоръжение B2C2K2R е в съответствие с Директива 2014/53/ЕС.

Цялостният текст на ЕС декларацията за съответствие може да се намери на следния интернет адрес:

<http://www.tokai-rika.co.jp/pc>

Радиочестотна лента: 433.050 - 434.790 MHz
Максимална радиочестотна мощност: 10mW(ERP)

Prin prezenta, TOKAI RIKAI CO., LTD. declară că tipul de echipamente radio B2C2K2R este în conformitate cu Directiva 2014/53/UE.

Textul integral al declarației UE de conformitate este disponibil la următoarea adresă internet:

<http://www.tokai-rika.co.jp/pc>

Banda de frecvență: 433.050 - 434.790 MHz
Puterea maximă de radiofrecvență: 10mW(ERP)

Ovime TOKAI RIKA CO., LTD. potvrđuje da je radio-oprema tipa B2C2K2R u skladu sa Direktivom 2014/53/EU.

Potpuni tekst EU deklaracije o usaglašenosti dostupan je na sljedećoj internet adresi:

<http://www.tokai-rika.co.jp/pc>

Frekvencijski opseg: 433.050 - 434.790 MHz
Maksimalna radio-frekvencijska snaga: 10mW(ERP)

Me anë të këtij dokumenti, TOKAI RIKA CO., LTD. deklaron se tipi i radiopajisjes B2C2K2R është në përputhje me Direktivën 2014/53/EU.

Teksti i plotë i deklaratës së konformitetit të Bashkimit Evropian është i disponueshëm në adresën e mëposhtme të internetit:

<http://www.tokai-rika.co.jp/pc>

Brezi i frekuencës: 433.050 - 434.790 MHz
Fuqia maksimale e radiofrekuencës: 10mW(ERP)

TOKAI RIKA CO., LTD. ovime izjavljuje da je radijska oprema tipa B2C2K2R u skladu s Direktivom 2014/53/EU.

Cjeloviti tekst EU izjave o sukladnosti dostupan je na sljedećoj internetskoj adresi:

<http://www.tokai-rika.co.jp/pc>

Frekvencijski pojas: 433.050 - 434.790 MHz
Maksimalna RF snaga: 10mW(ERP)

Ovim TOKAI RIKAI CO., LTD. potvrđuje da je radio-oprema tipa B2C2K2R u skladu sa Direktivom 2014/53/EU.

Potpuni tekst EU deklaracije o usaglašenosti dostupan je na sledećoj internet adresi:

<http://www.tokai-rika.co.jp/pc>

Frekventni opseg: 433.050 - 434.790 MHz

Maksimalna radio-frekventna snaga: 10mW(ERP)

TOKAI RIKAI CO., LTD., işbu belgeyle telsiz cihazı türünün B2C2K2R 2014/53/EU nolu Direktif ile uyumlu olduğunu beyan etmektedir.

AB uygunluk beyanının tam metnine aşağıdaki internet adresinden ulaşabilirsiniz:

<http://www.tokai-rika.co.jp/pc>

Frekans bandı: 433.050 - 434.790 MHz

Maksimum radyo frekans gücü: 10mW(ERP)



Address: 3-260 Toyota, Oguchi-cho, Niwa-gun, Aichi 480-0195, Japan

**WARNING****■ Caution regarding interference with electronic devices**

- People with implantable cardiac pacemakers, cardiac resynchronization therapy-pacemakers or implantable cardioverter defibrillators should maintain a reasonable distance between themselves and the smart entry & start system antennas. (→P.151) The radio waves may affect the operation of such devices. If necessary, the entry function can be disabled. Ask any authorized Lexus retailer or Lexus authorized repairer, or any reliable repairer for details, such as the frequency of radio waves and timing of the emitted radio waves. Then, consult your doctor to see if you should disable the entry function.
- Users of any electrical medical device other than implantable cardiac pacemakers, cardiac resynchronization therapy-pacemakers or implantable cardioverter defibrillators should consult the manufacturer of the device for information about its operation under the influence of radio waves. Radio waves could have unexpected effects on the operation of such medical devices.

Ask any authorized Lexus retailer or Lexus authorized repairer, or any reliable repairer for details on disabling the entry function.

Front seats

The seats can be adjusted (longitudinally, vertically, etc.). Adjust the seat to ensure the correct driving posture.

Adjustment procedure

▶ Manual seat

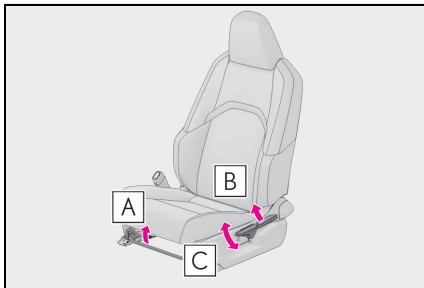

- A** Seat position adjustment lever
- B** Seatback angle adjustment lever
- C** Vertical height adjustment lever

▶ Power seat

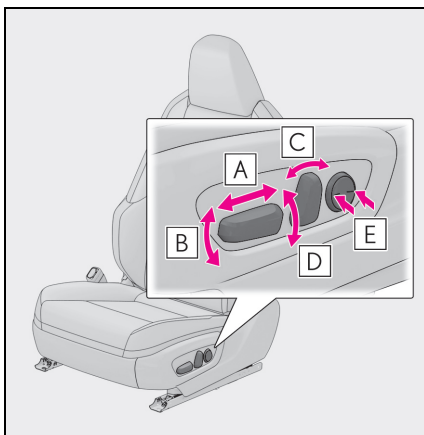

- A** Seat position adjustment switch

- B** Seat cushion (front) angle adjustment switch
- C** Seatback angle adjustment switch
- D** Vertical height adjustment switch
- E** Lumbar support adjustment switch (for driver's side)

■ When adjusting the seat

- Make sure that any surrounding passengers or objects are not contact the seat.
- Take care when adjusting the seat so that the head restraint does not touch the ceiling.

■ Power easy access system (vehicles with driving position memory)

The driver's seat and steering wheel move in accordance with engine switch over and the driver's seat belt condition. (→P.187)

■ Jam protection function (vehicles with driving position memory)

While the driving position is recalled or the power easy access system is operating, if an object is stuck behind the front seat, the front seat will stop and then slightly move forward. When the jam protection function operates, the seat stops at a position other than the set seat position. Check the seat position.

! WARNING

■ When adjusting the seat position

- Take care when adjusting the seat position to ensure that other passengers are not injured by the moving seat.
- Do not put your hands under the seat or near the moving parts to avoid injury. Fingers or hands may become jammed in the seat mechanism.

⚠ WARNING

- Make sure to leave enough space around the feet so they do not get stuck.

■ Seat adjustment

- To reduce the risk of sliding under the lap belt during a collision, do not recline the seat more than necessary. If the seat is too reclined, the lap belt may slide past the hips and apply restraint forces directly to the abdomen, or your neck may contact the shoulder belt, increasing the risk of death or serious injury in the event of an accident. Adjustments should not be made while driving as the seat may unexpectedly move and cause the driver to lose control of the vehicle.
- Manual seat: After adjusting the seat, make sure that the seat is locked in position.

Rear seats

The seatbacks of the rear seats can be folded down.

Folding down the rear seatbacks**■ Before folding down the rear seatbacks**

- 1 Park the vehicle in a safe place.

Apply the parking brake firmly and shift the shift lever to P. (→P.221)

- 2 Adjust the position of the front seat and the angle of the seatback. (→P.184)

Depending on the position of the front seat, if the seatback is folded backward, it may interfere with the operation of the rear seat.

- 3 Lower the head restraint of the rear seat. (→P.190)

- 4 Stow the armrest of the rear seat if it is pulled out. (→P.387)

This step is not necessary when operating the left side seat only.

■ Folding down rear seatbacks

Pull the seatback lock release lever and fold the seatback down.

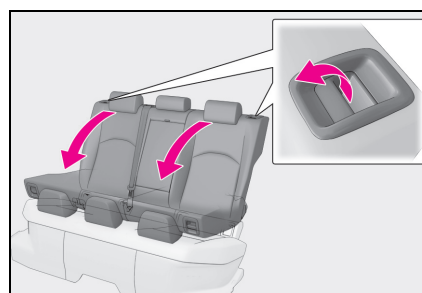

3

Before driving

■ Returning the rear seatbacks

To avoid trapping the seat belt between the seat and the inside of the vehicle, pass the seat belt inside the seat belt guide **A** and then return the seatback securely to the locked position.

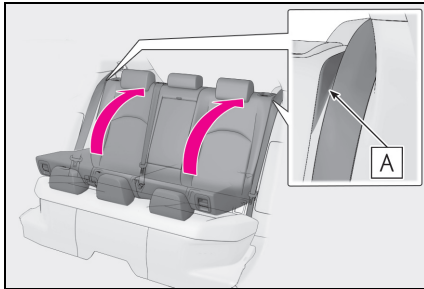

WARNING

■ When folding the rear seatbacks down

Observe the following precautions. Failure to do so may result in death or serious injury.

- Do not attempt to fold the seatbacks down while driving.
- Stop the vehicle on level ground, set the parking brake and shift the shift lever to P.
- Do not allow anyone to sit on a folded seatback or in the luggage compartment while driving.
- Do not allow children to enter the luggage compartment.
- Do not operate the rear seat if it is occupied.
- Be careful not to get feet or hands caught in the moving parts or joints of the seats during operation.
- Do not allow children to operate the seat.

■ After returning the rear seatback to the upright position

Observe the following precautions. Failure to do so may result in death or serious injury.

- Make sure that the seatback is securely locked in position by lightly pushing it back and forth. If the seatback is not securely locked, the red marking will be visible on the seatback lock release lever. Make sure that the red marking is not visible.

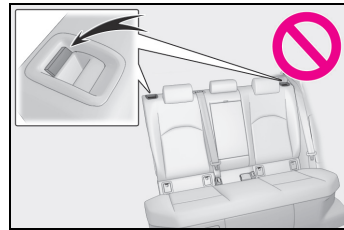

- Check that the seat belts are not twisted or caught in the seatback.

Driving position memory *

*: If equipped

This feature automatically adjusts the positions of the driver's seat, steering wheel, outside rear view mirrors and head-up display (if equipped) to make entering and exiting the vehicle easier or to suit your preferences.

Up to 3 different driving positions can be recorded.

Each electronic key (including a card key) can be registered to recall your preferred driving position.

Enabling easier driver entry and exit (power easy access system)

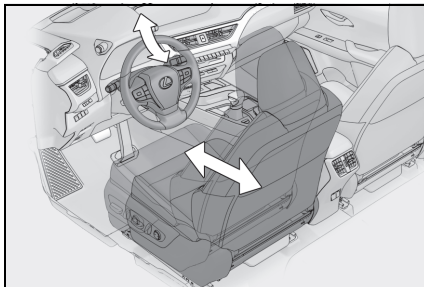

When all of the following have been performed, the driver's seat and steering wheel are automatically adjusted to a position that allows driver to enter and exit the vehicle easily.

- The shift lever has been shifted to P.
- The engine switch has been turned off.

- The driver's seat belt has been unfastened.

When any of the following has been performed, the driver's seat and steering wheel automatically return to their original positions.

- The engine switch has been turned to ACC or ON.
- The driver's seat belt has been fastened.

Operation of the power easy access system

When exiting the vehicle, the power easy access system may not operate if the seat is already close to the rearmost position, etc.

Customization

The seat movement amount settings of the power easy access system can be customized. (Customizable features: →P.506)

Recording a driving position into memory

- 1 Check that the shift lever is in P.
- 2 Turn the engine switch to ON.
- 3 Adjust the driver's seat, steering wheel, outside rear view mirrors and head-up display (if equipped) to the desired positions.
- 4 While pressing the "SET" button, or within 3 seconds after the "SET" button is pressed, press button "1", "2" or "3" until the buzzer sounds.

If the selected button has already been preset, the previously recorded position

will be overwritten.

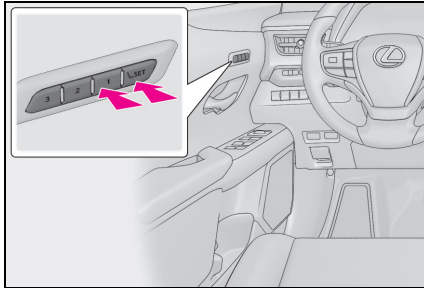

■ **Seat positions that can be memorized**
(→P.184)

The adjusted positions other than the position adjusted by lumbar support switch can be recorded.

■ **In order to correctly use the driving position memory function**

If a seat position is already in the furthest possible position and the seat is operated in the same direction, the recorded position may be slightly different when it is recalled.

⚠ WARNING

■ **Seat adjustment caution**

Take care during seat adjustment so that the seat does not strike the rear passenger or squeeze your body against the steering wheel.

Recalling a driving position

- 1 Check that the shift lever is in P.
- 2 Turn the engine switch to ON.

- 3 Press one of the buttons for the driving position you want to recall until the buzzer sounds.

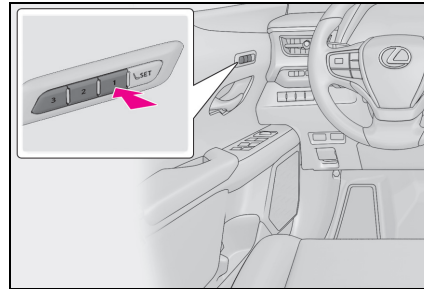

■ **To stop the position recall operation part-way through**

Perform any of the following:

- Press the "SET" button.
- Press button "1", "2" or "3".
- Operate any of the seat adjustment switches (only cancels seat position recall).
- Operate the tilt and telescopic steering control switch (only cancels steering wheel position recall).

■ **Operating the driving position memory after turning the engine switch off**

Recorded seat positions can be activated up to 180 seconds after the driver's door is opened and another 60 seconds after it is closed again.

Registering/canceling/recalling a driving position to an electronic key (including a card key*) (memory recall function)

*: If equipped

■ **Registering procedure**

Record your driving position to button "1", "2" or "3" before performing the following:

Carry only the key you want to register, and then close the driver's door.

If 2 or more keys are in the vehicle, the driving position cannot be recorded properly.

- 1 Check that the shift lever is in P.
- 2 Turn the engine switch to ON.
- 3 Recall the driving position that you want to record.
- 4 While pressing the recalled button, press and hold the door lock switch (either lock or unlock) until the buzzer sounds.

If the button could not be registered, the buzzer sounds continuously for approximately 3 seconds.

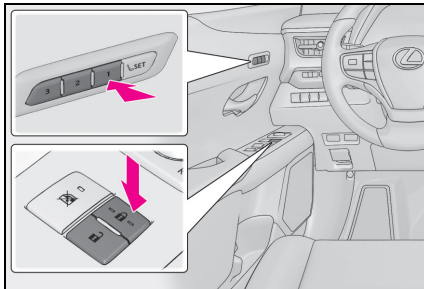

■ Cancellation procedure

- 1 Carry only the key you want to cancel and then close the driver's door.

If 2 or more keys are in the vehicle, the driving position cannot be canceled properly.

- 2 Turn the engine switch to ON.
- 3 While pressing the "SET" button, press and hold the door lock switch (either lock or unlock) until the buzzer sounds twice.

If it could not be canceled, the buzzer sounds continuously for approximately 3 seconds.

■ Recall procedure

- 1 Make sure that the doors are locked before recalling the driving position. Carry the electronic key that has been registered to the driving position, and then unlock and open the driver's door using the smart entry & start system or wireless remote control.

The driving position will move to the recorded position (not including the steering wheel and head-up display [if equipped]). However, the seat will move to a position slightly behind the recorded position in order to make entering the vehicle easier.

If the driving position is in a position that has already been recorded, the seat and outside rear view mirrors will not move.

- 2 Turn the engine switch to ACC or ON, or fasten a seat belt.

The seat and steering wheel and head-up display (if equipped) will move to the recorded position.

■ Recalling the driving position using the memory recall function

- Different driving positions can be registered for each electronic key. Therefore, the driving position that is recalled may be different depending on the key being carried.
- If a door other than the driver's door is unlocked with the smart entry & start system, the driving position cannot be recalled. In this case, press the driving position button which has been set.

■ Customization

The unlock door settings of the memory recall function can be customized. (Customizable features: →P.506)

Head restraints

Head restraints are provided for all seats.

⚠ WARNING

■ Head restraint precautions

Observe the following precautions regarding the head restraints. Failure to do so may result in death or serious injury.

- Use the head restraints designed for each respective seat.
- Adjust the head restraints to the correct position at all times.
- After adjusting the head restraints, push down on them and make sure they are locked in position.
- Do not drive with the head restraints removed.

Vertical adjustment

■ Front seats

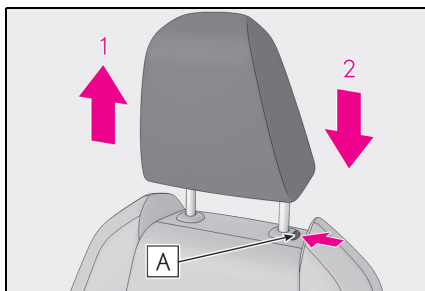

1 Up

Pull the head restraints up.

2 Down

Push the head restraint down while pressing the lock release button **A**.

■ Rear seats

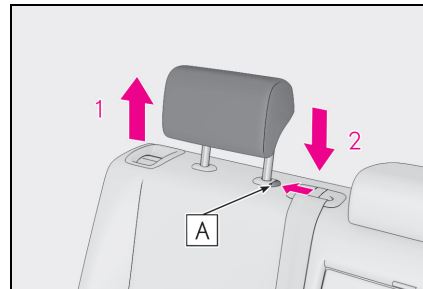

1 Up

Pull the head restraints up.

2 Down

Push the head restraint down while pressing the lock release button **A**.

■ Adjusting the height of the head restraints (front seats)

Make sure that the head restraints are adjusted so that the center of the head restraint is closest to the top of your ears.

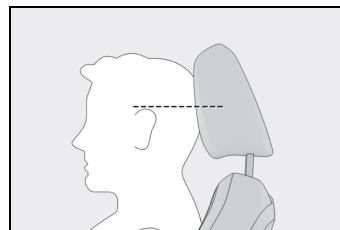

■ Adjusting the rear seat head restraint

Always raise the head restraint one level from the stowed position when using.

Horizontal adjustment (if equipped)

The position of the head restraint for the front seat can be adjusted forward in 4 stages.

If the head restraint is pulled forward from the foremost position, it will return to the

rearmost position.

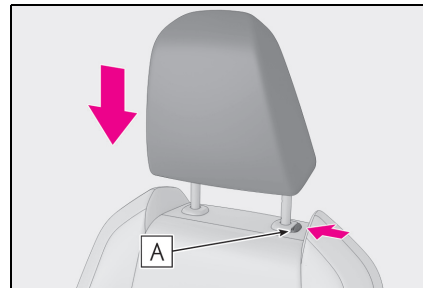
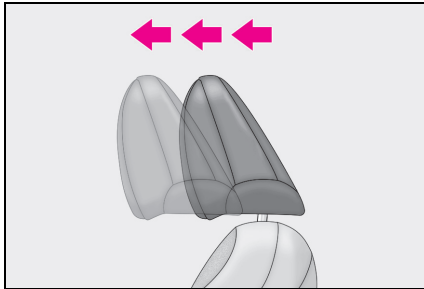

Removing the head restraints

Pull the head restraint up while pressing the lock release button **A**.
If the head restraint touches the ceiling, making the removal difficult, change the seat height or angle. (→P.184, 185)

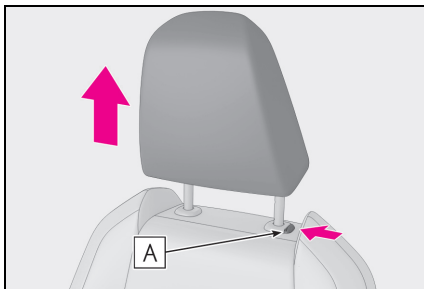

Installing the head restraints

Align the head restraint with the installation holes and push it down to the lock position.

Press and hold the lock release button **A** when lowering the head restraint.

Steering wheel

Adjustment procedure

► Manual type

- 1 Hold the steering wheel and push the lever down.

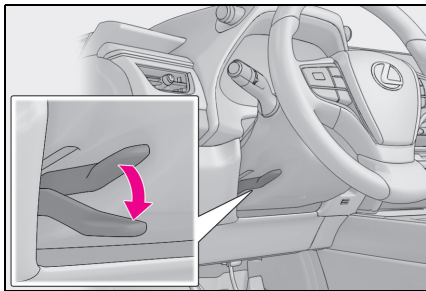

- 2 Adjust to the ideal position by moving the steering wheel horizontally and vertically.

After adjustment, pull the lever up to secure the steering wheel.

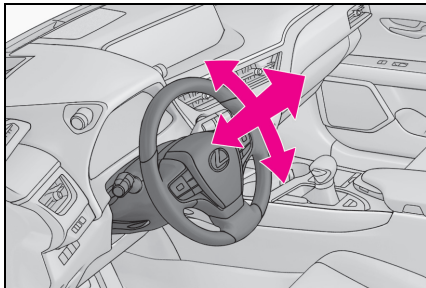

► Power type

Operating the switch moves the steering wheel in the following directions:

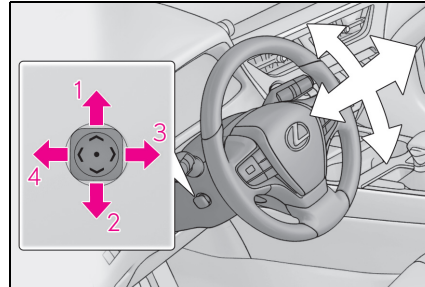

- 1 Up
- 2 Down
- 3 Toward the driver
- 4 Away from the driver

■ The steering wheel can be adjusted when (power type)

The engine switch is in ACC or ON*.

*: If the driver's seat belt is fastened, the steering wheel can be adjusted regardless of engine switch mode.

■ Automatic adjustment of the steering position (if equipped)

A desired steering position can be entered to memory and recalled automatically by the driving position memory system. (→P.187)

■ Power easy access system

The steering wheel and driver's seat move in accordance with engine switch mode and the driver's seat belt condition. (→P.187)

■ After adjusting the steering wheel (manual type)

Make sure that the steering wheel is securely locked.

The horn may not sound if the steering wheel is not securely locked.

⚠ WARNING**■ Caution while driving**

Do not adjust the steering wheel while driving.
Doing so may cause the driver to mishandle the vehicle and cause an accident, resulting in death or serious injury.

■ After adjusting the steering wheel (manual type)

Make sure that the steering wheel is securely locked.
Otherwise, the steering wheel may move suddenly, possibly causing an accident, and resulting in death or serious injury.

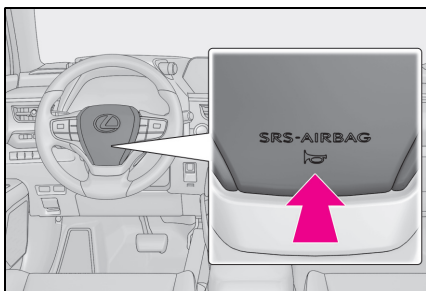
Sounding the horn

Press on or close to the  mark.

Inside rear view mirror

The rear view mirror's position can be adjusted to enable sufficient confirmation of the rear view.

Adjusting the height of rear view mirror

The height of the rear view mirror can be adjusted to suit your driving posture.

Adjust the height of the rear view mirror by moving it up and down.

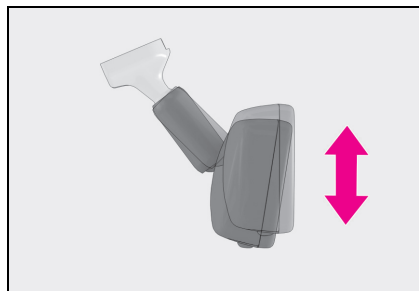
**⚠ WARNING****■ Caution while driving**

Do not adjust the position of the mirror while driving.
Doing so may lead to mishandling of the vehicle and cause an accident, resulting in death or serious injury.

Anti-glare function**► Manual anti-glare inside rear view mirror**

Reflected light from the headlights of vehicles behind can be reduced by operating the lever.

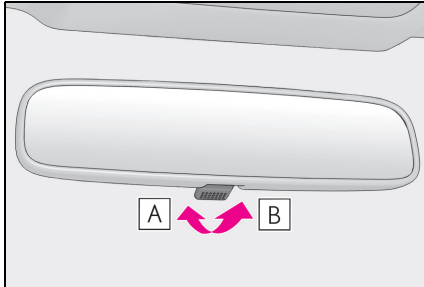

A Normal position

B Anti-glare position

- ▶ Auto anti-glare inside rear view mirror

Responding to the level of brightness of the headlights of vehicles behind, the reflected light is automatically reduced.

Turn the automatic anti-glare function mode on/off

When the automatic anti-glare function is in ON mode, the indicator **A** illuminates. The function will set to ON mode each time the engine switch is turned to ON. Pressing the button turns the function to OFF mode. (The indicator **A** also turns off.)

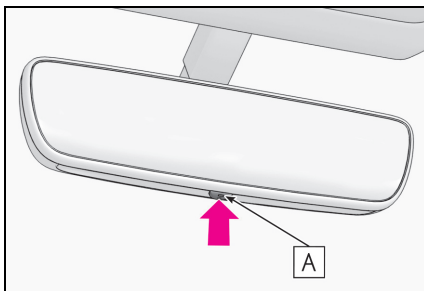

■ **To prevent sensor error (vehicles with auto anti-glare inside rear view mirror)**

To ensure that the sensors operate properly,

do not touch or cover them.

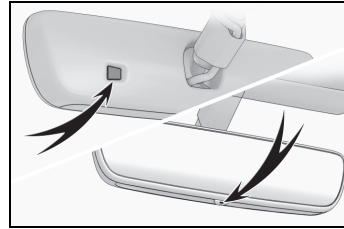

Outside rear view mirrors

The rear view mirror's position can be adjusted to enable sufficient confirmation of the rear view.

⚠ WARNING

■ Important points while driving

Observe the following precautions while driving. Failing to do so may result in loss of control of the vehicle and cause an accident, resulting in death or serious injury.

- Do not adjust the mirrors while driving.
- Do not drive with the mirrors folded.
- Both the driver and passenger side mirrors must be extended and properly adjusted before driving.

Adjustment procedure

- 1 To select a mirror to adjust, press the switch.

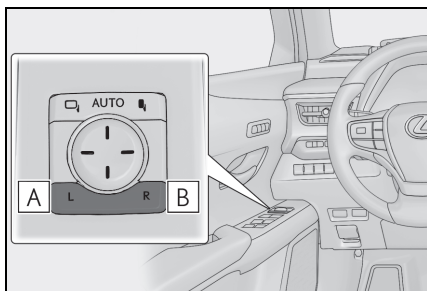

- A** Left
- B** Right

- 2 To adjust the mirror, press the switch.

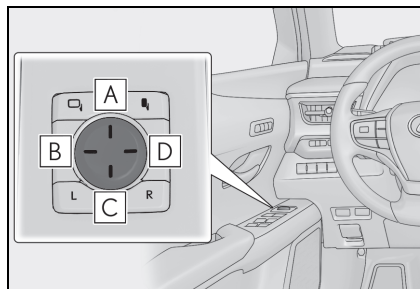

- A** Up
- B** Left
- C** Down
- D** Right

■ Mirror angle can be adjusted when

The engine switch is in ACC or ON.

■ Defogging the mirrors

The outside rear view mirrors can be cleared using the mirror defoggers. Turn on the rear window defogger to turn on the outside rear view mirror defoggers. (→P.357)

■ Auto anti-glare function (if equipped)

When the anti-glare inside rear view mirror is set to automatic mode, the outside rear view mirrors will activate in conjunction with the anti-glare inside rear view mirror to reduce reflected light. (→P.193)

■ Automatic adjustment of the mirror angle (vehicles with driving position memory)

A desired mirror face angle can be entered to memory and recalled automatically by the driving position memory. (→P.187)

⚠ WARNING**■ When the mirror defoggers are operating**

Do not touch the rear view mirror surfaces, as they can become very hot and burn you.

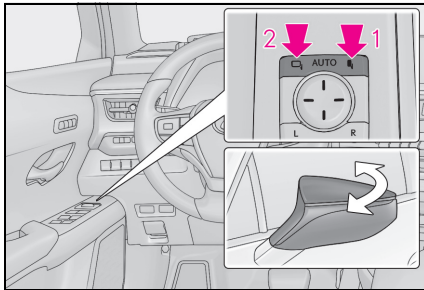
Folding and extending the mirrors

- 1** Fold
- 2** Extend

Putting the outside rear view mirror folding switch in the neutral position sets the mirrors to automatic mode. Automatic mode allows the folding or extending of the mirrors to be linked to locking/unlocking of the doors.

■ Using automatic mode in cold weather (if equipped)

When automatic mode is used in cold weather, the door mirror could freeze up and automatic stowing and return may not be possible. In this event, after removing any ice and snow from the door mirror, operate the mirror using manual mode or move it by hand.

■ Customization

The automatic mirror folding and extending operation can be changed. (Customizable features: →P.506)

⚠ WARNING**■ When a mirror is moving**

To avoid personal injury and mirror malfunction, be careful not to get your hand caught by the moving mirror.

Linked mirror function when reversing (vehicles with driving position memory)

When the mirror select switch is in the “L” or “R” position, the outside rear view mirrors will automatically angle downwards when the vehicle is reversing in order to give a better view of the ground.

To disable this function, move the mirror select switch to the neutral position (between “L” or “R”)

■ Adjusting the mirror angle when the vehicle is reversing

With the shift lever in R, adjust the mirror angle to a desired position.

The adjusted angle will be memorized and the mirror will automatically tilt to the memorized angle whenever the shift lever is shifted to R from next time.

The memorized downward tilt position of the mirror is linked to the normal position (angle adjusted with the shift lever in other than R). Therefore, if the normal position is changed after adjustment, the tilt position will also change.

When the normal position is changed, readjust the angle in reversing.

Power windows

Opening and closing the power windows

The power windows can be opened and closed using the switches.

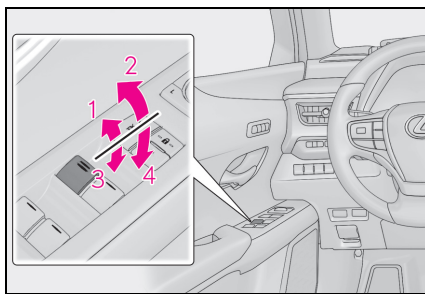

- 1 Closing
- 2 One-touch closing *
- 3 Opening
- 4 One-touch opening *

*: To stop the window partway, operate the switch in the opposite direction.

■ The power windows can be operated when

The engine switch is in ON.

■ Operating the power windows after turning the engine off

The power windows can be operated for approximately 45 seconds even after the engine switch is turned to ACC or OFF. They cannot, however, be operated once either front door is opened.

■ Jam protection function

If an object becomes jammed between the window and the window frame while the window is closing, window movement is stopped and the window is opened slightly.

■ Catch protection function

If an object becomes caught between the

door and window while the window is opening, window movement is stopped.

■ When the window cannot be opened or closed

When the jam protection function or catch protection function operates unusually and the side window cannot be opened or closed, perform the following operations with the power window switch of that door.

- Stop the vehicle. With the engine switch in ON, within 4 seconds of the jam protection function or catch protection function activating, continuously operate the power window switch in the one-touch closing direction or one-touch opening direction so that the side window can be opened and closed.

- If the side window cannot be opened and closed even when performing the above operations, perform the following procedure for function initialization.

- 1 Turn the engine switch to ON.
- 2 Pull and hold the power window switch in the one-touch closing direction and completely close the side window.
- 3 Release the power window switch for a moment, resume pulling the switch in the one-touch closing direction, and hold it there for approximately 6 seconds or more.
- 4 Press and hold the power window switch in the one-touch opening direction. After the side window is completely opened, continue holding the switch for an additional 1 second or more.
- 5 Release the power window switch for a moment, resume pushing the switch in the one-touch opening direction, and hold it there for approximately 4 seconds or more.
- 6 Pull and hold the power window switch in the one-touch closing direction again. After the side window is completely closed, continue holding the switch for a further 1 second or more.

If you release the switch while the window is moving, start again from the beginning. If the window reverses and cannot be fully

closed or opened, have the vehicle inspected by any authorized Lexus retailer or Lexus authorized repairer, or any reliable repairer.

■ Door lock linked window operation

- The power windows can be opened and closed using the mechanical key.* (→P.481)
- The power windows can be opened and closed using the wireless remote control.* (→P.134)

*: These settings must be customized at any authorized Lexus retailer or Lexus authorized repairer, or any reliable repairer.

■ Power windows open warning buzzer

The buzzer sounds and “Window Open” is shown on the multi-information display in the instrument cluster when the engine switch is turned off and the driver’s door is opened with the power windows open.

■ Customization

Setting (e.g. linked door lock operation) can be changed. (Customizable features: →P.507)



WARNING

Observe the following precautions. Failing to do so may result in death or serious injury.

■ Closing the windows

- The driver is responsible for all the power window operations, including the operation for the passengers. In order to prevent accidental operation, especially by a child, do not let a child operate the power windows. It is possible for children and other passengers to have body parts caught in the power window. Also, when riding with a child, it is recommended to use the window lock switch. (→P.199)

- Check to make sure that all passengers do not have any part of their body in a position where it could be caught when a window is being operated.

- When using the wireless remote control or mechanical key and operating the power windows, operate the power window after checking to make sure that there is no possibility of any passenger having any of their body parts caught in the window. Also do not let a child operate window by the wireless remote control or mechanical key. It is possible for children and other passengers to get caught in the power window.

- When exiting the vehicle, turn the engine switch off, carry the key and exit the vehicle along with the child. There may be accidental operation, due to mischief, etc., that may possibly lead to an accident.

■ Jam protection function

- Never use any part of your body to intentionally activate the jam protection function.

- The jam protection function may not work if something gets jammed just before the window is fully closed. Be careful not to get any part of your body jammed in the window.

■ Catch protection function

- Never use any part of your body or clothing to intentionally activate the catch protection function.

- The catch protection function may not work if something gets caught just before the window is fully opened. Be careful not to get any part of your body or clothing caught in the window.

Preventing accidental operation (window lock switch)

This function is designed to prevent children from accidentally opening or closing a passenger window.

Press the switch.

The indicator **A** will come on and the passenger window will be locked.

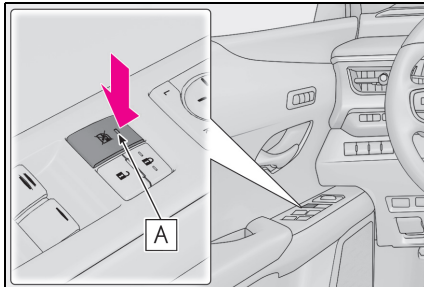

■ The power windows can be operated when

The engine switch is in ON.

■ When the battery is disconnected

The window lock switch is disabled. If necessary, press the window lock switch after reconnecting the battery.

Moon roof*

*: If equipped

Use the overhead switches to open and close the moon roof and tilt it up and down.

Operating the moon roof

■ Opening and closing

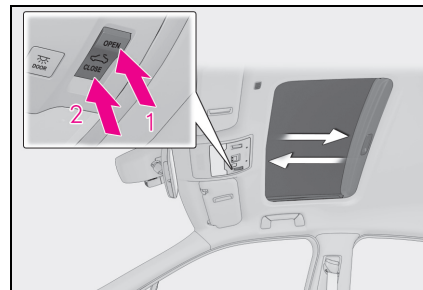

1 Opens the moon roof*

The moon roof tilts up and then fully opens.

2 Closes the moon roof*

*: Lightly press either side of the moon roof switch to stop the moon roof partway.

■ Tilting up and down

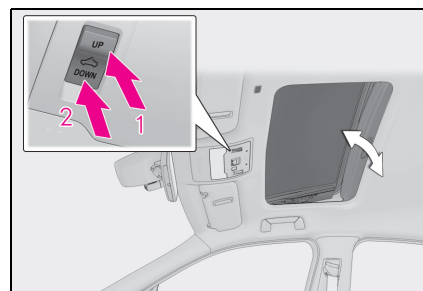

1 Tilts the moon roof up*

2 Tilts the moon roof down*

*: Lightly press either side of the moon roof

3

Before driving

switch to stop the moon roof partway.

■ **The moon roof can be operated when**

The engine switch is in ON.

■ **Operating the moon roof after turning the engine off**

The moon roof can be operated for approximately 45 seconds after the engine switch is turned to ACC or OFF. It cannot, however, be operated once either front door is opened.

■ **Jam protection function**

If an object is detected between the moon roof and the frame while the moon roof is closing or tilting down, travel is stopped and the moon roof opens slightly.

■ **Sunshade**

The sunshade can be opened and closed manually. However, the sunshade will open automatically when the moon roof is opened.

■ **Door lock linked moon roof operation**

- The moon roof can be opened and closed using the mechanical key. * (→P.481)
- The moon roof can be opened and closed using the wireless remote control. * (→P.134)

* : These settings must be customized at any authorized Lexus retailer or Lexus authorized repairer, or any reliable repairer.

■ **When the moon roof does not close normally**

Perform the following procedure:

- 1 Stop the vehicle.
- 2 Press and hold the "CLOSE" switch. *

The moon roof will close, reopen and pause for approximately 10 seconds. Then it will close again and stop at the completely closed position.

- 3 Check to make sure that the moon roof is completely closed and then release the switch.

* : If the switch is released at the incorrect time, the procedure will have to be performed again from the beginning.

If the moon roof does not fully close even after performing the above procedure correctly, have the vehicle inspected by any authorized Lexus retailer or Lexus authorized repairer, or any reliable repairer.

■ **If the moon roof does not move normally**

If the moon roof does not open or close normally or the automatic opening function does not operate, perform the following initialization procedure.

- 1 Stop the vehicle.
- 2 Press and hold the "DOWN" switch. *

The moon roof will stop at the tilt-up position. After that, it will open, close, tilt up, tilt down, and stop at the fully closed position.

- 3 Confirm that the moon roof has completely stopped and release the switch.

* : If you release the switch while the moon roof is moving, perform the procedure again from the beginning.

If, after performing the above procedures correctly, the moon roof still does not open or close normally or the automatic opening function does not operate, have the vehicle inspected by any authorized Lexus retailer or Lexus authorized repairer, or any reliable repairer.

■ **Moon roof open warning buzzer**

A buzzer sounds and "Moon Roof Open" is shown on the multi-information display in the instrument cluster when the engine switch is turned off and the driver's door is opened with the moon roof open.

■ **Customization**

Some functions can be customized. (→P.507)

⚠ WARNING

Observe the following precautions. Failure to do so may cause death or serious injury.

■ Opening the moon roof

- Do not allow any passengers to put their hands or heads outside the vehicle while it is moving.
- Do not sit on top of the moon roof.

■ Opening and closing the moon roof

- The driver is responsible for moon roof opening and closing operations. In order to prevent accidental operation, especially by a child, do not let a child operate the moon roof. It is possible for children and other passengers to have body parts caught in the moon roof.
- Check to make sure that all passengers do not have any part of their body in a position where it could be caught when the moon roof is being operated.
- When using the wireless remote control or mechanical key and operating the moon roof, operate the moon roof after checking to make sure that there is no possibility of any passenger having any of their body parts caught in the moon roof. Also, do not let a child operate moon roof by the wireless remote control or mechanical key. It is possible for children and other passengers to get caught in the moon roof.
- When exiting the vehicle, turn the engine switch off, carry the key and exit the vehicle along with the child. There may be accidental operation, due to mischief, etc., that may possibly lead to an accident.

■ Jam protection function

- Never use any part of your body to intentionally activate the jam protection function.

- The jam protection function may not work if something gets caught just before the moon roof is fully closed. Also, the jam protection function is not designed to operate while the moon roof switch is being pressed. Take care so that your fingers, etc. do not get caught.

- 4-1. Before driving**
 - Driving the vehicle..... **204**
 - Cargo and luggage..... **209**
 - Trailer towing (vehicles without towing package)..... **211**
 - Trailer towing (vehicles with towing package) **211**
- 4-2. Driving procedures**
 - Engine (ignition) switch **217**
 - Multidrive **220**
 - Turn signal lever **224**
 - Parking brake **225**
 - Brake Hold..... **228**
 - ASC (Active Sound Control/Acceleration Sound Control)..... **230**
- 4-3. Operating the lights and wipers**
 - Headlight switch..... **231**
 - AHS (Adaptive High-beam System) **233**
 - Automatic High Beam **237**
 - Fog light switch **239**
 - Windshield wipers and washer **241**
 - Rear window wiper and washer **245**
- 4-4. Refueling**
 - Opening the fuel tank cap..... **247**
- 4-5. Using the driving support systems**
 - Lexus Safety System+ **249**
 - PCS (Pre-Collision System) **260**
 - LTA (Lane Tracing Assist) **268**
 - RSA (Road Sign Assist) **277**
 - Dynamic radar cruise control with full-speed range **281**
 - Cruise control **292**
 - Stop & Start system..... **294**
 - BSM (Blind Spot Monitor)..... **301**
 - PKSA (Parking Support Alert) **312**
 - Lexus parking assist-sensor .. **313**
 - RCTA (Rear Crossing Traffic Alert) function **320**
 - PKSB (Parking Support Brake) **324**
 - Parking Support Brake function (static objects) **328**
 - Parking Support Brake function (rear-crossing vehicles) **333**
 - Driving mode select switch .. **337**
 - Exhaust Gas Filter system..... **339**
 - Driving assist systems **339**
- 4-6. Driving tips**
 - Winter driving tips **344**
 - Utility vehicle precautions..... **347**

Driving the vehicle

The specified procedures should be observed to ensure safe driving:

Driving procedure

■ Starting the engine

→P.217

■ Driving

- 1 With the brake pedal depressed, shift the shift lever to D. (→P.220)
- 2 If the parking brake is in manual mode, release the parking brake. (→P.225)
- 3 Gradually release the brake pedal and gently depress the accelerator pedal to accelerate the vehicle.

■ Stopping

- 1 With the shift lever in D, depress the brake pedal.
- 2 If necessary, set the parking brake. (→P.225)

If the vehicle is to be stopped for an extended period of time, shift the shift lever to P. (→P.220)

■ Parking the vehicle

- 1 With the shift lever in D, depress the brake pedal.
- 2 If the parking brake is in manual mode, set the parking brake (→P.225), and shift the shift lever to P (→P.220).
- 3 Press the engine switch to stop the engine.

- 4 Lock the door, making sure that you have the electronic key on your person.

If parking on a hill, block the wheels as needed.

■ Starting off on a steep uphill

- 1 Make sure that the parking brake is set with the brake pedal depressed, and then shift the shift lever to D.
- 2 Release the brake pedal and gently depress the accelerator pedal.
- 3 Release the parking brake.

■ When starting off on a uphill

The hill-start assist control will be activated. (→P.340)

■ Driving in the rain

- Drive carefully when it is raining, because visibility will be reduced, the windows may become fogged-up, and the road will be slippery.
- Drive carefully when it starts to rain, because the road surface will be especially slippery.
- Refrain from high speeds when driving on an expressway in the rain, because there may be a layer of water between the tires and the road surface, preventing the steering and brakes from operating properly.

■ Engine speed while driving

In the following conditions, the engine speed may become high while driving. This is due to automatic up-shifting control or down-shifting implementation to meet driving conditions. It does not indicate sudden acceleration.

- The vehicle is judged to be driving uphill or downhill
- When the accelerator pedal is released
- When the brake pedal is depressed while Sport mode is selected

■ Restraining the engine output (Brake Override System)

- When the accelerator and brake pedals are depressed at the same time, the engine output may be restrained.
- A warning message is displayed on the multi-information display and head-up display (if equipped) while the system is operating. (→P.449)

■ Restraining sudden start (Drive-Start Control)

- When the following unusual operation is performed, the engine output may be restrained.
 - When the shift lever is shifted from R to D, D to R, N to R, P to D, or P to R (D includes M) with the accelerator pedal depressed, a warning message appears on the multi-information display and head-up display (if equipped). If a warning message is shown on the multi-information display and head-up display, read the message and follow the instructions.
 - When the accelerator pedal is depressed too much while the vehicle is in reverse.
- While Drive-Start Control is being activated, your vehicle may have trouble escaping from the mud or fresh snow. In such case, deactivate TRC (→P.340) to cancel Drive-Start Control so that the vehicle may become able to escape from the mud or fresh snow.

■ Breaking in your new Lexus

To extend the life of the vehicle, observing the following precautions is recommended:

- For the first 300 km (200 miles):
Avoid sudden stops.
- For the first 2000 km (1200 miles):
 - Do not drive at extremely high speeds.
 - Avoid sudden acceleration.
 - Do not drive continuously in low gears.
 - Do not drive at a constant speed for extended periods.
- ▶ Vehicles with towing package
 - For the first 800 km (500 miles):
Do not tow a trailer.

■ Operating your vehicle in a foreign country

Comply with the relevant vehicle registration laws and confirm the availability of the correct fuel. (→P.499)

⚠ WARNING

Observe the following precautions. Failure to do so may result in death or serious injury.

■ When starting the vehicle

Always keep your foot on the brake pedal while stopped with the engine running. This prevents the vehicle from creeping.

■ When driving the vehicle

- Do not drive if you are unfamiliar with the location of the brake and accelerator pedals to avoid depressing the wrong pedal.
 - Accidentally depressing the accelerator pedal instead of the brake pedal will result in sudden acceleration that may lead to an accident.
 - When backing up, you may twist your body around, leading to difficulty in operating the pedals. Make sure to operate the pedals properly.
 - Make sure to keep a correct driving posture even when moving the vehicle only slightly. This allows you to depress the brake and accelerator pedals properly.
 - Depress the brake pedal using your right foot. Depressing the brake pedal using your left foot may delay response in an emergency, resulting in an accident.
- Do not drive the vehicle over or stop the vehicle near flammable materials. The exhaust system and exhaust gases can be extremely hot. These hot parts may cause a fire if there is any flammable material nearby.

**WARNING**

- During normal driving, do not turn off the engine. Turning the engine off while driving will not cause loss of steering or braking control, but the power assist to these systems will be lost. This will make it more difficult to steer and brake, so you should pull over and stop the vehicle as soon as it is safe to do so.
However, in the event of an emergency, such as if it becomes impossible to stop the vehicle in the normal way: →P.436
 - Use engine braking (downshift) to maintain a safe speed when driving down a steep hill. Using the brakes continuously may cause the brakes to overheat and lose effectiveness. (→P.220)
 - Do not adjust the positions of the steering wheel, the seat, or the inside or outside rear view mirrors while driving.
Doing so may result in a loss of vehicle control.
 - Always check that all passengers' arms, heads or other parts of their body are not outside the vehicle.
- **When driving on slippery road surfaces**
- Sudden braking, acceleration and steering may cause tire slippage and reduce your ability to control the vehicle.
 - Sudden acceleration, engine braking due to shifting, or changes in engine speed could cause the vehicle to skid, resulting in an accident.

- After driving through a puddle, lightly depress the brake pedal to make sure that the brakes are functioning properly. Wet brake pads may prevent the brakes from functioning properly. If the brakes on only one side are wet and not functioning properly, steering control may be affected.

■ **When shifting the shift lever**

- Do not let the vehicle roll backward while the shift lever is in a driving position, or roll forward while the shift lever is in R.
Doing so may cause the engine to stall or lead to poor brake and steering performance, resulting in an accident or damage to the vehicle.
- Do not shift the shift lever to P while the vehicle is moving.
Doing so can damage the transmission and may result in a loss of vehicle control.
- Do not shift the shift lever to R while the vehicle is moving forward.
Doing so can damage the transmission and may result in a loss of vehicle control.
- Do not shift the shift lever to a driving position while the vehicle is moving backward.
Doing so can damage the transmission and may result in a loss of vehicle control.
- Shifting the shift lever to N while the vehicle is moving will disengage the engine.
Engine braking is not available when N is selected.
- Be careful not to shift the shift lever with the accelerator pedal depressed.
Shifting the shift lever to any position other than P or N may lead to unexpected rapid acceleration of the vehicle that may cause an accident and result in death or serious injury.

⚠ WARNING**■ If you hear a squealing or scraping noise (brake pad wear indicators)**

Have the brake pads checked and replaced by any authorized Lexus retailer or Lexus authorized repairer, or any reliable repairer as soon as possible. Rotor damage may result if the pads are not replaced when needed.

Front brakes only (except Azerbaijan, Armenia, Kazakhstan, Russia, Ukraine, Georgia and Israel): Moderate levels of brake pad and disc wear allow enhanced front braking power. As a result, the discs may wear more quickly than conventional brake discs. Therefore, when replacing the brake pads, Lexus recommends that you also have the thickness of the discs measured.

It is dangerous to drive the vehicle when the wear limits of the brake pads and/or those of the brake discs are exceeded.

■ When the vehicle is stopped

- Do not race the engine.
If the shift lever is in any position other than P or N, the vehicle may accelerate suddenly and unexpectedly, causing an accident.
- In order to prevent accidents due to the vehicle rolling away, always keep depressing the brake pedal while the engine is running, and apply the parking brake as necessary.
- If the vehicle is stopped on an incline, in order to prevent accidents caused by the vehicle rolling forward or backward, always depress the brake pedal and securely apply the parking brake as needed.
- Avoid revving or racing the engine.
Running the engine at high speed while the vehicle is stopped may cause the exhaust system to overheat, which could result in a fire if combustible material is nearby.

■ When the vehicle is parked

- Do not leave glasses, cigarette lighters, spray cans, or soft drink cans in the vehicle when it is in the sun.
Doing so may result in the following:
 - Gas may leak from a cigarette lighter or spray can, and may lead to a fire.
 - The temperature inside the vehicle may cause the plastic lenses and plastic material of glasses to deform or crack.
 - Soft drink cans may fracture, causing the contents to spray over the interior of the vehicle, and may also cause a short circuit in the vehicle's electrical components.
- Do not leave cigarette lighters in the vehicle. If a cigarette lighter is in a place such as the glove box or on the floor, it may be lit accidentally when luggage is loaded or the seat is adjusted, causing a fire.
- Do not attach adhesive discs to the windshield or windows. Do not place containers such as air fresheners on the instrument panel or dashboard. Adhesive discs or containers may act as lenses, causing a fire in the vehicle.
- Do not leave a door or window open if the curved glass is coated with a metallized film such as a silver-colored one. Reflected sunlight may cause the glass to act as a lens, causing a fire.
- Always shift the shift lever to P, apply the parking brake, stop the engine and lock the vehicle.
Do not leave the vehicle unattended while the engine is running.
If the vehicle is parked with the shift lever in P but the parking brake is not set, the vehicle may start to move, possibly leading to an accident.
- Do not touch the exhaust pipes while the engine is running or immediately after turning the engine off.
Doing so may cause burns.

**WARNING****■ When taking a nap in the vehicle**

Always turn the engine off. Otherwise, if you accidentally move the shift lever or depress the accelerator pedal, this could cause an accident or fire due to engine overheating. Additionally, if the vehicle is parked in a poorly ventilated area, exhaust gases may collect and enter the vehicle, leading to death or a serious health hazard.

■ When braking

- When the brakes are wet, drive more cautiously.
Braking distance increases when the brakes are wet, and this may cause one side of the vehicle to brake differently than the other side. Also, the parking brake may not securely hold the vehicle.
- If the brake booster device does not operate, do not follow other vehicles closely and avoid hills or sharp turns that require braking.
In this case, braking is still possible, but the brake pedal should be depressed more firmly than usual. Also, the braking distance will increase. Have your brakes fixed immediately.
- Do not pump the brake pedal if the engine stalls.
Each push on the brake pedal uses up the reserve for the power-assisted brakes.
- The brake system consists of 2 individual hydraulic systems; if one of the systems fails, the other will still operate. In this case, the brake pedal should be depressed more firmly than usual and the braking distance will increase. Have your brakes fixed immediately.

**NOTICE****■ When driving the vehicle**

- Do not depress the accelerator and brake pedals at the same time during driving, as this may restrain the engine output.
- Do not use the accelerator pedal or depress the accelerator and brake pedals at the same time to hold the vehicle on a hill.

■ Avoiding damage to vehicle parts

- Do not turn the steering wheel fully in either direction and hold it there for an extended period of time.
Doing so may damage the power steering motor.
- When driving over bumps in the road, drive as slowly as possible to avoid damaging the wheels, underside of the vehicle, etc.

■ If you get a flat tire while driving

A flat or damaged tire may cause the following situations. Hold the steering wheel firmly and gradually depress the brake pedal to slow down the vehicle.

- It may be difficult to control your vehicle.
- The vehicle will make abnormal sounds or vibrations.
- The vehicle will lean abnormally.

Information on what to do in case of a flat tire (→P.455, 467, 476)

■ When encountering flooded roads

Do not drive on a road that has flooded after heavy rain, etc. Doing so may cause the following serious damage to the vehicle:

- Engine stalling
- Short in electrical components
- Engine damage caused by water immersion

**NOTICE**

In the event that you drive on a flooded road and the vehicle is flooded, be sure to have any authorized Lexus retailer or Lexus authorized repairer, or any reliable repairer check the following:

- Brake function
- Changes in quantity and quality of oil and fluid used for the engine, transmission, etc.
- Lubricant condition for the bearings and suspension joints (where possible), and the function of all joints, bearings, etc.

■ When parking the vehicle

Always set the parking brake, and shift the shift lever to P. Failure to do so may cause the vehicle to move or the vehicle may accelerate suddenly if the accelerator pedal is accidentally depressed.

Cargo and luggage

Take notice of the following information about storage precautions, cargo capacity and load:

**WARNING****■ Things that must not be carried in the luggage compartment**

The following things may cause a fire if loaded in the luggage compartment:

- Receptacles containing gasoline
- Aerosol cans

■ Storage precautions

Observe the following precautions. Failure to do so may prevent the pedals from being depressed properly, may block the driver's vision, or may result in items hitting the driver or passengers, possibly causing an accident.

- Stow cargo and luggage in the luggage compartment whenever possible.
- Do not stack cargo and luggage in the luggage compartment higher than the seatbacks.
- When you fold down the rear seats, long items should not be placed directly behind the front seats.
- Never allow anyone to ride in the luggage compartment. It is not designed for passengers. They should ride in their seats with their seat belts properly fastened.

**WARNING**

- Do not place cargo or luggage in or on the following locations.
 - At the feet of the driver
 - On the front passenger or rear seats (when stacking items)
 - On the luggage cover
 - On the instrument panel
 - On the dashboard
 - In front of the Center Display

- Secure all items in the occupant compartment.

■ Load and distribution

- Do not overload your vehicle.
- Do not apply loads unevenly. Improper loading may cause deterioration of steering or braking control which may cause death or serious injury.

■ When using a roof luggage carrier (vehicles with roof rails)

Observe the following precautions:

- Place the cargo so that its weight is distributed evenly between the front and rear axles.
- If loading long or wide cargo, never exceed the vehicle overall length or width. (→P.490)
- Before driving, make sure the cargo is securely fastened on the roof luggage carrier.
- Loading cargo on the roof luggage carrier will make the center of gravity of the vehicle higher. Avoid high speeds, sudden starts, sharp turns, sudden braking or abrupt maneuvers, otherwise it may result in loss of control or vehicle rollover due to failure to operate this vehicle correctly and result in death or serious injury.

- If driving for a long distance, on rough roads, or at high speeds, stop the vehicle now and then during the trip to make sure the cargo remains in its place.

- Do not exceed 80 kg (176.3 lb.) cargo weight on the roof luggage carrier.

**NOTICE****■ When loading cargo (vehicles with moon roof)**

Be careful not to scratch the surface of the moon roof.

Trailer towing (vehicles without towing package)

Lexus does not recommend towing a trailer with your vehicle. Lexus also does not recommend the installation of a tow hitch or the use of a tow hitch carrier for a wheelchair, scooter, bicycle, etc. Your vehicle is not designed for trailer towing or for the use of tow hitch mounted carriers.



Trailer towing (vehicles with towing package)

Your vehicle is designed primarily as a passenger carrying vehicle. Towing a trailer will have an adverse effect on handling, performance, braking, durability, and fuel consumption. Your safety and satisfaction depend on the proper use of correct equipment and cautious driving habits. For your safety and the safety of others, do not overload the vehicle or trailer.

To tow a trailer safely, use extreme care and drive the vehicle in accordance with the trailer's characteristics and operating conditions. Lexus warranties do not apply to damage or malfunction caused by towing a trailer for commercial purposes.

Ask your local authorized Lexus retailer or Lexus authorized repairer, or any reliable repairer for further details before towing, as there are additional legal requirements in some countries.

Weight limits

Check the allowable towing capacity, GVM (Gross Vehicle Mass), MPAC (Maximum Permissible Axle Capacity), and permissible drawbar load before towing. (→P.490)

Towing hitch/bracket

Lexus recommends the use of the Lexus hitch/bracket for your vehicle. Other products of a suitable nature and comparable quality may also be used.

Connecting trailer lights

Please consult any authorized Lexus retailer or Lexus authorized repairer, or any reliable repairer when installing trailer lights, as incorrect installation may cause damage to the vehicle's lights. Please take care to comply with your state's laws when installing trailer lights.

Important points regarding trailer loads

■ **Total trailer weight and permissible drawbar load**

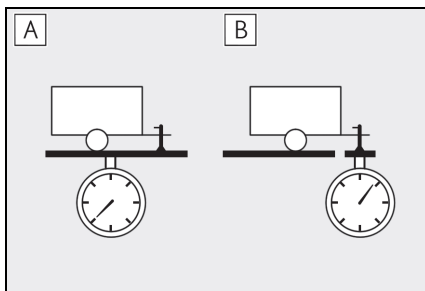

A Total trailer weight
Weight of the trailer itself plus the trailer load should be within the maximum towing capacity. Exceeding this weight is dangerous. (→P.490)

B Permissible drawbar load

Allocate the trailer load so that the drawbar load is greater than 25 kg (55.1lb.) or 4% of the towing capacity. Do not let the drawbar load exceed the indicated weight. (→P.490)

■ **Information tag (manufacturer's label)**

▶ Type A

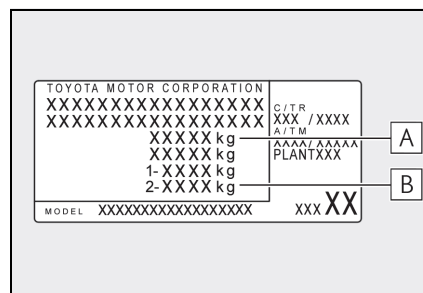

A Gross vehicle mass
The combined weight of the driver, passengers, luggage, towing hitch, total curb mass and drawbar load should not exceed the gross vehicle mass by more than 100 kg (220.5 lb.). Exceeding this weight is dangerous.

B Maximum permissible rear axle capacity
The weight borne by the rear axle should not exceed the maximum permissible axle capacity by 15% or more. Exceeding this weight is dangerous.
The values for towing capacity were derived from testing conducted at sea level. Take note that engine output and towing capacity will be reduced at high altitudes.

► Type B

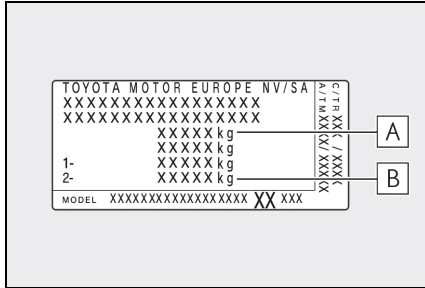

A Gross vehicle mass

The combined weight of the driver, passengers, luggage, towing hitch, total curb mass and drawbar load should not exceed the gross vehicle mass by more than 100 kg (220.5 lb.). Exceeding this weight is dangerous.

B Maximum permissible rear axle capacity

The weight borne by the rear axle should not exceed the maximum permissible axle

capacity by 15% or more. Exceeding this weight is dangerous.

The values for towing capacity were derived from testing conducted at sea level. Take note that engine output and towing capacity will be reduced at high altitudes.

WARNING

- When the gross vehicle mass limit or maximum permissible axle capacity is exceeded

Failing to observe this precaution may lead to an accident causing death or serious injury.

- Add an additional 20.0 kPa (0.2 kgf/cm² or bar, 3 psi) to the recommended tire inflation pressure value. (→P.496)
- Do not exceed the established speed limit for towing a trailer in built-up areas or 100 km/h (62 mph), whichever is lower.

Installation positions for the towing hitch/bracket and hitch ball

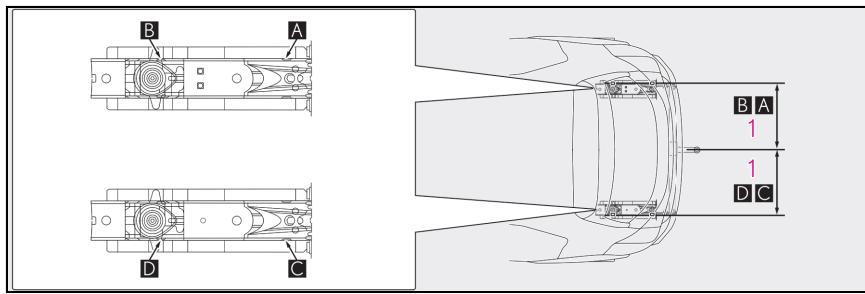

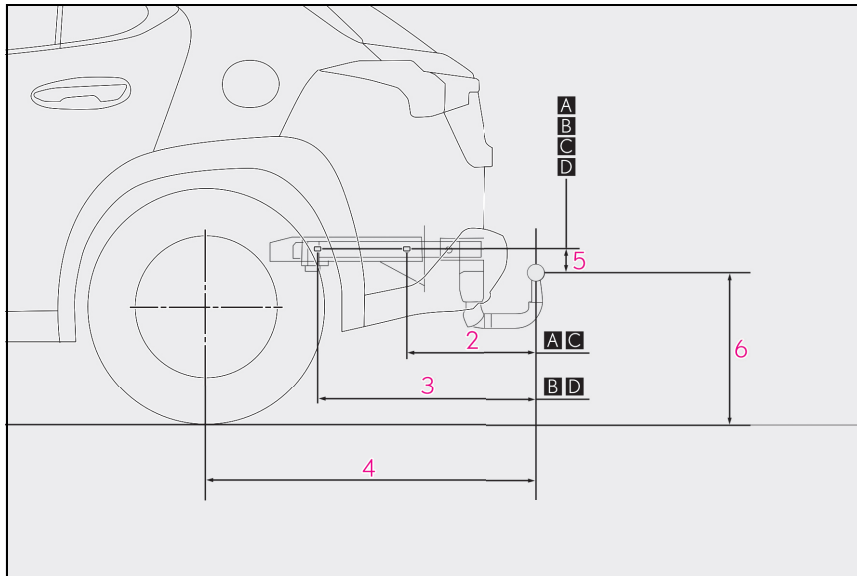

- 1 519 mm (20.4 in.)
- 2 382 mm (15.0 in.)
- 3 644 mm (25.4 in.)
- 4 976 mm (38.4 in.)
- 5 71 mm (2.8 in.)
- 6 375 mm (14.8 in.)

■ **Tire information**

- Increase the tire inflation pressure to 20.0 kPa (0.2 kgf/cm² or bar, 3 psi) greater than the recommended value when towing. (→P.496)
- Increase the air pressure of the trailer tires in accordance with the total trailer weight and according to the values recommended by the manufacturer of your trailer.

■ **Trailer lights**

Please consult at any authorized Lexus retailer or Lexus authorized repairer, or any reliable repairer when installing trailer lights, as incorrect installation may cause damage to the vehicle's lights. Please take care to comply with your state's laws when installing trailer lights.

■ **Break-in schedule**

Lexus recommends that vehicles fitted with new power train components should not be used for towing trailers for the first 800 km (500 miles).

■ **Safety checks before towing**

- Check that the maximum load limit for the towing hitch/bracket and hitch ball is not exceeded. Bear in mind that the coupling weight of the trailer will add to the load exerted on the vehicle. Also make sure that the total load exerted on the vehicle is within the range of the weight limits. (→P.213)
- Ensure that the trailer load is secure.
- Supplementary outside rear view mirrors should be added to the vehicle if the traffic behind cannot be clearly seen with standard mirrors. Adjust the extending

arms of these mirrors on both sides of the vehicle so that they always provide maximum visibility of the road behind.

■ Maintenance

- Maintenance must be performed more frequently when using the vehicle for towing due to the greater weight burden placed on the vehicle compared to normal driving.
- Retighten all bolts securing the hitching ball and bracket after towing for approximately 1000 km (600 miles).



NOTICE

■ When the rear bumper strengthening material is aluminum

Ensure the steel bracket part does not come directly in contact with that area. When steel and aluminum come into contact, there is a reaction similar to corrosion, which will weaken the section concerned and may result in damage. Apply a rust inhibitor to parts that will come in contact when attaching a steel bracket.

Guidance

Your vehicle will handle differently when towing a trailer. In order to avoid accident, death or serious injury, keep the following in mind when towing:

■ Checking connections between trailer and lights

Stop the vehicle and check the operation of the connection between the trailer and lights after driving for a brief period as well as before starting off.

■ Practicing driving with a coupled trailer

- Get the feel for turning, stopping and reversing with the trailer cou-

pled by practicing in an area with no or light traffic.

- When reversing with a coupled trailer, hold the section of the steering wheel nearest to you and rotate clockwise to turn the trailer left or counterclockwise to turn it right. Always rotate a little at a time to prevent steering error. Have someone guide you when reversing to lessen the risk of an accident.

■ Increasing vehicle-to-vehicle distance

At a speed of 10 km/h (6 mph), the distance to the vehicle running ahead of you should be equivalent to or greater than the combined length of your vehicle and trailer. Avoid sudden braking that may cause skidding. Otherwise, the vehicle may spin out of control. This is especially true when driving on wet or slippery road surfaces.

■ Sudden acceleration/steering input/cornering

Executing sharp turns when towing may result in the trailer colliding with your vehicle. Decelerate well in advance when approaching turns and take them slowly and carefully to avoid sudden braking.

■ Important points regarding turning

The wheels of the trailer will travel closer to the inside of the curve than the wheels of the vehicle. To make allowance for this, take the turns wider than you would normally do.

■ Important points regarding stability

Vehicle movement resulting from uneven road surfaces and strong crosswinds will affect handling. The vehicle may also be rocked by passing buses or large trucks. Frequently check behind when moving alongside such vehicles. As soon as such vehicle movement occurs, immediately start to decelerate smoothly by slowly applying the brakes. Always steer the vehicle straight ahead while braking.

■ Passing other vehicles

Consider the total combined length of your vehicle and trailer and ensure that the vehicle-to-vehicle distance is sufficient before executing lane changes.

■ Transmission information

To maintain engine braking efficiency and charging system performance when using engine braking, do not use the transmission in D. (→P.220)

■ If the engine overheats

Towing a loaded trailer up a long, steep incline in temperatures exceeding 30°C (85°F) may result in the engine overheating. If the engine coolant temperature gauge indicates that the engine is overheating, turn the air conditioning off immediately, leave the road and stop the vehicle in a safe place. (→P.485)

■ When parking the vehicle

Always place wheel chocks under the wheels of both the vehicle and trailer.

Set the parking brake and shift the shift lever to P.

WARNING

Follow all the instructions described in this section.

Failure to do so could cause an accident resulting in death or serious injury.

■ Trailer towing precautions

When towing, make sure that none of the weight limits are exceeded. (→P.212)

■ To avoid accident or injury

- Vehicles with compact spare tire:
Do not tow a trailer when the compact spare tire is installed on your vehicle.
- Vehicles with emergency tire puncture repair kit:
Do not tow a trailer when the tire installed is repaired with the emergency tire puncture repair kit.
- Do not use the following systems when trailer towing.
 - Cruise control (if equipped)
 - Dynamic radar cruise control with full-speed range (if equipped)

■ Vehicle speed in towing

Observe the legal maximum speeds for trailer towing.

■ Before descending hills or long declines

Reduce speed and downshift. However, never downshift suddenly while descending steep or long downhill grades.

■ Operation of the brake pedal

Do not hold the brake pedal depressed often or for long periods of time. Doing so may result in the brake overheating or reduce braking effects.

Engine (ignition) switch

Performing the following operations when carrying the electronic key on your person starts the engine or changes engine switch modes.

Starting the engine

- 1 Press the parking brake switch to check that the parking brake is set. (→P.225)

Parking brake indicator will come on.

- 2 Check that the shift lever is in P.
- 3 Firmly depress the brake pedal.

 and a message will be displayed on the multi-information display.

If it is not displayed, the engine cannot be started.

- 4 Press the engine switch shortly and firmly.

When operating the engine switch, one short, firm press is enough.

It is not necessary to press and hold the switch.

The engine will crank until it starts or for up to 30 seconds, whichever is less.

Continue depressing the brake pedal until the engine is completely started.

The engine can be started from any engine

switch mode.

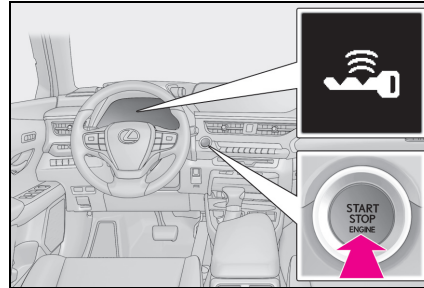

■ Engine switch illumination

According to the situation, the engine switch illumination operates as follows.

- When a door is opened, or the engine switch mode is changed from ACC or ON to OFF, the engine switch illumination slowly blinks.
- When depressing the brake pedal with carrying the electronic key on your person, the engine switch illumination rapidly blinks.
- When the engine switch is in ACC or ON, the engine switch illumination illuminates.

■ If the engine does not start

- The engine immobilizer system may not have been deactivated. (→P.84)
Contact any authorized Lexus retailer or Lexus authorized repairer, or any reliable repairer.
- If a message related to start-up is shown on the multi-information display, read the message and follow the instructions.
- The smart entry & start system may not be operating properly. (→P.481)

■ Electronic key battery depletion

→P.130

■ Conditions affecting operation

→P.153

■ Note for the entry function

→P.153

■ **Steering lock function**

- After turning the engine switch off and opening and closing the doors, the steering wheel will be locked due to the steering lock function. Operating the engine switch again automatically cancels the steering lock.
- When the steering lock cannot be released, "Push ENGINE Switch while Turning the Steering Wheel in Either Direction" will be displayed on the multi-information display. Check that the shift lever is in P. Press the engine switch shortly and firmly while turning the steering wheel left and right.

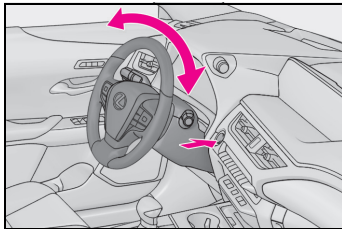

- To prevent the steering lock motor from overheating, operation of the motor may be suspended if the engine is turned on and off repeatedly in a short period of time. In this case, refrain from running the engine. After about 10 seconds, the steering lock motor will resume functioning.

■ **Electronic key battery**

→P.428

■ **Operation of the engine switch**

- If the switch is not pressed shortly and firmly, the engine switch mode may not change or the engine may not start.
- If attempting to restart the engine immediately after turning the engine switch off, the engine may not start in some cases. After turning the engine switch off, please wait a few seconds before restarting the engine.

■ **Customization**

If the smart entry & start system has been deactivated in a customized setting, refer to P.480.

! WARNING

■ **When starting the engine**

Always start the engine while sitting in the driver's seat. Do not depress the accelerator pedal while starting the engine under any circumstances. Doing so may cause an accident resulting in death or serious injury.

■ **Caution while driving**

If engine failure occurs while the vehicle is moving, do not lock or open the doors until the vehicle reaches a safe and complete stop. The steering lock function will activate and this may lead to an accident, resulting in death or serious injury.

! NOTICE

■ **When starting the engine**

- Do not race a cold engine.
- If the engine becomes difficult to start or stalls frequently, have your vehicle checked by any authorized Lexus retailer or Lexus authorized repairer, or any reliable repairer immediately.

■ **Symptoms indicating a malfunction with the engine switch**

If the engine switch seems to be operating somewhat differently than usual, such as the switch sticking slightly, there may be a malfunction. Contact any authorized Lexus retailer or Lexus authorized repairer, or any reliable repairer immediately.

Stopping the engine

- 1 Stop the vehicle completely.
- 2 Set the parking brake (→P.225), and shift the shift lever to P (→P.220).
- 3 Press the engine switch shortly and firmly.

- 4 Release the brake pedal and check that “ACCESSORY” or “IGNITION ON” is not shown on the meter.

⚠ WARNING

■ **Stopping the engine in an emergency**

- If you want to stop the engine in an emergency while driving the vehicle, press and hold the engine switch for more than 2 seconds, or press it briefly 3 times or more in succession. (→P.436)

However, do not touch the engine switch while driving except in an emergency. Turning the engine off while driving will not cause loss of steering or braking control, but the power assist to these systems will be lost. This will make it more difficult to steer and brake, so you should pull over and stop the vehicle as soon as it is safe to do so.

- If the engine switch is operated while the vehicle is running, a warning message will be shown on the multi-information display and a buzzer sounds.
- When restarting the engine after an emergency shutdown, shift the shift lever to N and press the engine switch shortly and firmly.

Changing engine switch modes

Modes can be changed by pressing the engine switch with the brake pedal released. (The mode changes each time the switch is pressed.)

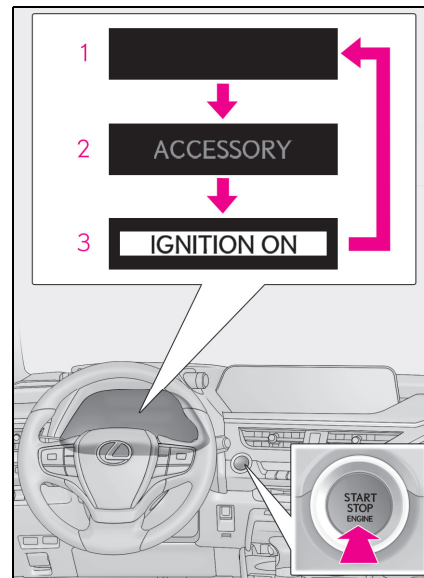

1 OFF*

The emergency flashers can be used.

2 ACC

Some electrical components such as the audio system can be used. “ACCESSORY” will be displayed on the meter.

3 ON

All electrical components can be used. “IGNITION ON” will be displayed on the meter.

- * : If the shift lever is in a position other than P when turning off the engine, the engine switch will be turned to ACC, not to OFF.

■ **Auto power off function**

If the vehicle is left in ACC for more than 20 minutes or ON (the engine is not running) for more than an hour with the shift lever in P, the engine switch will automatically turn off. However, this function cannot entirely prevent battery discharge. Do not leave the vehicle with the engine switch in

ACC or ON for long periods of time when the engine is not running.

 NOTICE

- **To prevent battery discharge**
- Do not leave the engine switch in ACC or ON for long periods of time without the engine running on.
- If “ACCESSORY” or “IGNITION ON” is displayed on the multi-information display while the engine is not running, the engine switch is not OFF. Exit the vehicle after turning the engine switch off.
- Do not stop the engine when the shift lever is in a position other than P. If the engine is stopped in another shift lever position, the engine switch will not be turned off but instead be turned to ACC. If the vehicle is left in ACC, battery discharge may occur.

When stopping the engine with the shift lever in a position other than P

If the engine is stopped with the shift lever in a position other than P, the engine switch will not be turned off but instead be turned to ACC. Perform the following procedure to turn the switch off:

- 1 Check that the parking brake is set.
- 2 Shift the shift lever to P.
- 3 Check that “Turn Power Off” is displayed on the multi-information display and then press the engine switch shortly and firmly once.
- 4 Check that “Turn Power Off” on the multi-information display is off.

Multidrive

Select the shift position depending on your purpose and situation.

Shift position purpose and functions

Shift position	Objective or function
P	Parking the vehicle/starting the engine
R	Reversing
N	Neutral (Condition in which the power is not transmitted)
D	Normal driving ^{*1}
M	10-speed sport sequential shiftmatic mode driving ^{*2} (→P.223)

^{*1}: To improve fuel efficiency and reduce noise, shift the shift lever to D for normal driving.
^{*2}: Selecting gear steps using the M position achieves suitable engine braking forces by operating the shift lever or paddle shift switches.

■ **Reverse warning buzzer**

When shifting into R, a buzzer will sound to inform the driver that the shift lever is in R.

■ **To protect the transmission**

If the automatic transmission fluid temperature is high, “Transmission Oil Temp. High Stop in a Safe Place and See Owner’s Manual” will be displayed on the multi-information display and the vehicle will go into transmission protection mode automatically. Have the vehicle inspected by any

authorized Lexus retailer or Lexus authorized repairer, or any reliable repairer.

■ Multidrive fail-safe control

The system detects malfunctioning parts targeted (all of the solenoids that perform the shifting function) by the On-Board Diagnostics, and performs fail-safe mechanisms, such as restricting the shifting function or transmission ratio control. In this event, the malfunction indicator lamp turns on.

■ When driving with cruise control (if equipped) or dynamic radar cruise control with full-speed range (if equipped) activated

Even when switching the driving mode to Sport mode while driving in D position (→P.337) with the intent of enabling engine braking, engine braking will not activate because cruise control (if equipped) or dynamic radar cruise control with full-speed range (if equipped) will not be canceled.

■ Restraining sudden start (Drive-Start Control)

→P.205

■ AI-SHIFT

AI-SHIFT automatically selects the suitable gear step according to driver performance and driving conditions.

AI-SHIFT automatically operates when the driving mode is set to Normal mode with the shift lever in D. (Shifting the shift lever to M cancels the function.)

■ G AI-SHIFT

G AI-SHIFT automatically selects the suitable gear step according to driver's input and driving conditions. G AI-SHIFT operates automatically when the shift lever is in the D position and Sport mode is selected for the driving mode. (Selecting Normal mode or shifting the shift lever to the M position cancels the function.)

! WARNING

■ When driving on slippery road surfaces

Be careful of downshifting and sudden acceleration, as this could result in the vehicle skidding to the side or spinning.

Shifting the shift lever

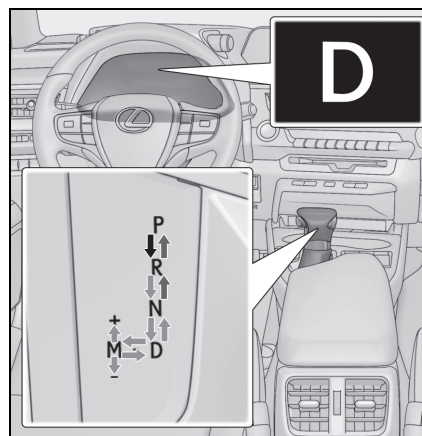

← While the engine switch is in ON and the brake pedal depressed*, shift the shift lever while pushing the shift release button on the shift knob.

← Shift the shift lever while pushing the shift release button on the shift knob.

← Shift the shift lever normally.

When shifting the shift lever between P and D, make sure that the vehicle is completely stopped and the brake pedal is depressed.

* : For the vehicle be able to be shifted from P, the brake pedal must be depressed before the shift release button is pushed. If the shift release button is pushed first, the shift lock will not be released.

■ **Shift lock system**

The shift lock system is a system to prevent accidental operation of the shift lever in starting.

The shift lever can be shifted from P only when the engine switch is in ON, the brake pedal is depressed and the shift release button is pushed.

■ **If the shift lever cannot be shifted from P**

First, check whether the brake pedal is being depressed. If the shift lever cannot be shifted even though the brake pedal is depressed and the shift release button is pushed, there may be a problem with the shift lock system. Have the vehicle inspected by any authorized Lexus retailer or Lexus authorized repairer, or any reliable repairer immediately.

The following steps may be used as an emergency measure to ensure that the shift lever can be shifted.

Releasing the shift lock:

- 1 Press the parking brake switch to check that the parking brake is set. (→P.225)
- 2 Turn the engine switch off.
- 3 Depress the brake pedal.
- 4 Pry the cover up with a flathead screwdriver or equivalent tool.

To prevent damage to the cover, cover the tip of the screwdriver with a rag.

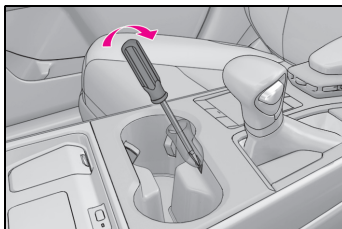

- 5 Press the shift lock override button.

The shift lever can be shifted while the button is pressed.

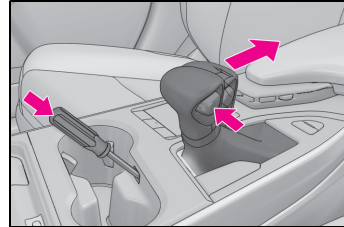

⚠ WARNING

■ **To prevent an accident when releasing the shift lock**

Before pressing the shift lock override button, make sure to set the parking brake and depress the brake pedal. If the accelerator pedal is accidentally depressed instead of the brake pedal when the shift lock override button is pressed and the shift lever is shifted out of P, the vehicle may suddenly start, possibly leading to an accident resulting in death or serious injury.

Selecting the driving mode

→P.337

Selecting gear steps in the D position (vehicles with paddle shift switches)

To drive using temporary gear step selection, operate the “-” or “+” paddle shift switch when driving with the shift lever in D.

Changing the gear step allows restriction of the highest gear, preventing unnecessary upshifting and enabling the level of engine braking force to be selected.

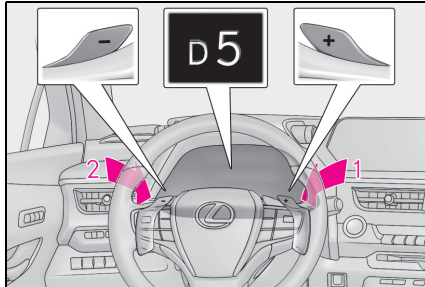

- 1 Upshifting
- 2 Downshifting

The selected gear step, from D1 to D10, will be displayed in the meter.

To return to normal D position driving, the "+" paddle shift switch must be held down for a period of time.

■ Gear step functions

- 10 levels of accelerating force and engine braking can be selected.
- A lower gear step will provide greater accelerating force and engine braking force than a higher gear step, and the engine revolutions will also increase.

■ Automatic deactivation of shift range selection in the D position

Shift range selection in the D position will be deactivated in the following situations:

- When the vehicle comes to a stop
- If the accelerator pedal is depressed for more than a certain period of time
- When the shift lever is shifted to a position other than D
- When the "+" paddle shift switch is pressed and held

■ Downshifting restriction warning buzzer

To help ensure safety and driving performance, downshifting operation may sometimes be restricted. In some circumstances, downshifting may not be possible even when the paddle shift switch is operated. (A buzzer will sound twice.)

Changing gear steps in the M position

To enter 10-speed sport sequential shiftmatic mode, shift the shift lever to M. Gear steps can be selected by operating the shift lever or paddle shift switches (if equipped).

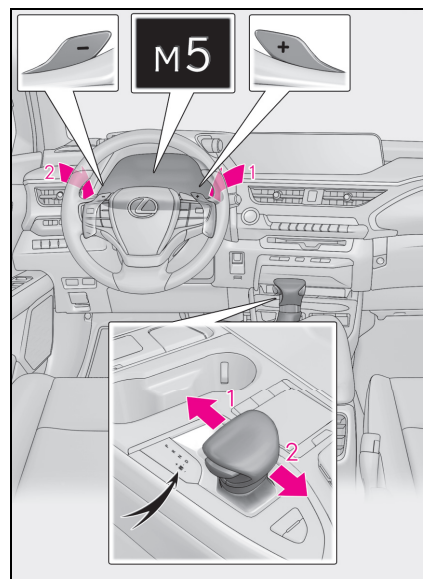

- 1 Upshifting
- 2 Downshifting

The gear step changes once every time the shift lever or paddle shift switch (if equipped) is operated.

The selected gear step, from M1 to M10, will be displayed in the meter.

However, even when in the M position, the gear steps will be automatically changed if the engine speed is too high, or too low.

■ **Gear step functions**

- 10 levels of accelerating force and engine braking can be selected.
- A lower gear step will provide greater accelerating force and engine braking force than a higher gear step, and the engine revolutions will also increase.

■ **Downshifting restriction warning buzzer**

To help ensure safety and driving performance, downshifting operation may sometimes be restricted. In some circumstances, downshifting may not be possible even when the shift lever or paddle shift switch (if equipped) is operated. (A buzzer will sound twice.)

■ **When the vehicle comes to a stop with the shift lever in the M position**

- The transmission will automatically downshift to M1 once the vehicle is stopped.
- After a stop, the vehicle will start off in M1.
- When the vehicle is stopped, the transmission is set at M1.

■ **If the "M" indicator does not come on or the "D" indicator is displayed even after shifting the shift lever to M**

This may indicate a malfunction in the automatic transmission system. Have the vehicle inspected by any authorized Lexus retailer or Lexus authorized repairer, or any reliable repairer immediately. (In this situation, the transmission will operate in the same manner as when the shift lever is in D.)

Turn signal lever

Operating instructions

The turn signal lever can be used to show the following intentions of the driver.

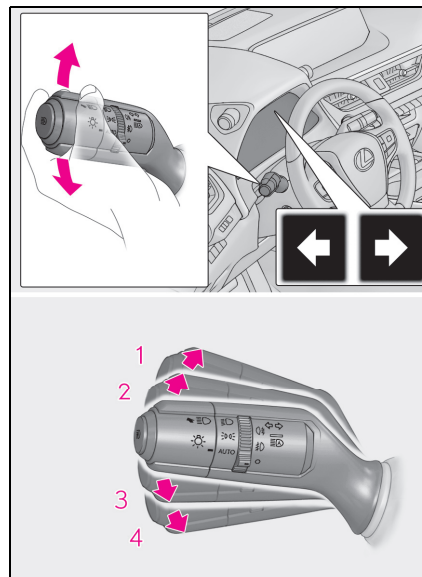

- 1 Right turn
- 2 Lane change to the right (move the lever partway and release it)
The right hand signals will flash 3 times.
- 3 Lane change to the left (move the lever partway and release it)
The left hand signals will flash 3 times.
- 4 Left turn

■ **Turn signals can be operated when**

The engine switch is in ON.

■ **If the indicator flashes faster than usual**

Check that a light bulb in the front or rear turn signal lights has not burned out.

- If the turn signals stop flashing before a lane change has been performed

Operate the lever again.

Parking brake

The parking brake can be set or released automatically or manually. In automatic mode, the parking brake can be set or released automatically according to shift lever operation. Also, even in automatic mode, the parking brake can be set or released manually.

Operating instructions

■ Using the manual mode

The parking brake can be set and released manually.

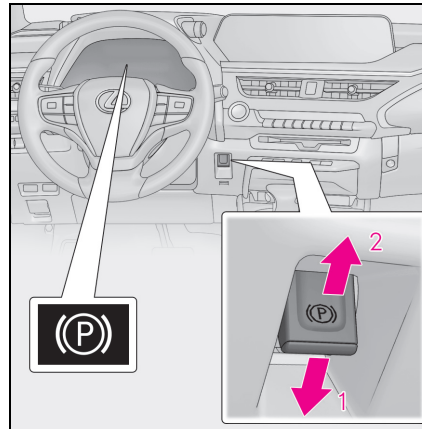

- 1 Push the switch to set the parking brake

The parking brake indicator light will turn on.

Press and hold the parking brake switch if an emergency occurs and it is necessary to operate the parking brake while driving.

- 2 Pull the switch to release the parking brake

- Operate the parking brake switch while depressing the brake pedal.
- Using the parking brake automatic release function, the parking brake can be released by depressing the accelerator pedal. When using this function, slowly depress the accelerator pedal.

Make sure that the parking brake indicator light turn off.

■ **Turning the automatic mode on**

While the vehicle is stopped, press and hold the parking brake switch until a message is shown on the multi-information display

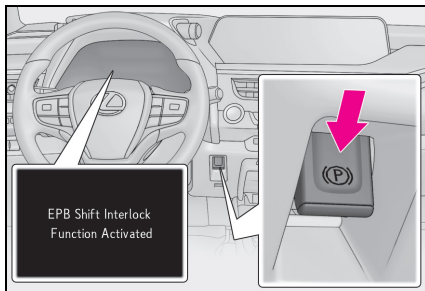

When the automatic mode is turned on, the parking brake operates as follows.

- When the shift lever is shifted from P, the parking brake will be released, and the parking brake indicator light will turn off.
- When the shift lever is shifted to P, the parking brake will be set, and the parking brake indicator light will turn on.

Operate the shift lever with the vehicle stopped and the brake pedal depressed.

■ **Turning the automatic mode off**

While the vehicle is stopped, pull and hold the parking brake switch until a message is shown on the multi-information display

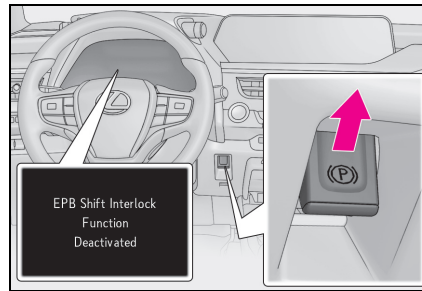

■ **Parking brake operation**

- When the engine switch is not in ON, the parking brake cannot be released using the parking brake switch.
- When the engine switch is not in ON, automatic mode (automatic brake setting and releasing) is not available.

■ **Parking brake automatic release function**

- When the shift lever is shifted from P, the parking brake will be released in automatic mode.
- When all of the following conditions are met in manual mode, the parking brake can be released by depressing the accelerator pedal.
 - The driver's door is closed
 - The driver is wearing the seat belt
 - The shift lever is in D, M or R

■ **If "Parking Brake Temporarily Unavailable" is displayed on the multi-information display**

If the parking brake is operated repeatedly over a short period of time, the system may restrict operation to prevent overheating. If this happens, refrain from operating the parking brake. Normal operation will return after about 1 minute.

■ **If “Parking Brake Unavailable” or “EPB Unavailable” is displayed on the multi-information display**

Operate the parking brake switch. If the message does not disappear after operating the switch several times, the system may be malfunctioning. Have the vehicle inspected by any authorized Lexus retailer or Lexus authorized repairer, or any reliable repairer.

■ **Parking brake operation sound**

When the parking brake operates, a motor sound (whirring sound) may be heard. This does not indicate a malfunction.

■ **Parking brake indicator light**

- Depending on the engine switch mode, the parking brake indicator light will turn on and stay on as described below:
ON: Comes on until the parking brake is released.
Not in ON: Stays on for approximately 15 seconds.
- When the engine switch is turned off with the parking brake set, the parking brake indicator light will stay on for about 15 seconds. This does not indicate a malfunction.

■ **When the parking brake switch malfunctions**

Automatic mode (automatic brake setting and releasing) will be turned on automatically.

■ **Parking the vehicle**

→P.204

■ **Parking brake engaged warning buzzer**

A buzzer will sound if the vehicle is driven with the parking brake engaged. “EPB Applied” is displayed on the multi-information display (with the vehicle reached a speed of 5 km/h [3 mph]).

■ **If the brake system warning light comes on**

→P.444

■ **Usage in winter time**

→P.344

 **WARNING**

■ **When parking the vehicle**

Do not leave a child in the vehicle alone. The parking brake may be released unintentionally and there is the danger of the vehicle moving that may lead to an accident resulting in death or serious injury.

 **NOTICE**

■ **When parking the vehicle**

Before you leave the vehicle, shift the shift lever to P, set the parking brake and make sure that the vehicle does not move.

■ **When the system malfunctions**

Stop the vehicle in a safe place and check the warning messages.

■ **When the parking brake cannot be released due to a malfunction**

Driving the vehicle with the parking brake set will lead to brake components overheating, which may affect braking performance and increase brake wear.

Have the vehicle inspected by any authorized Lexus retailer or Lexus authorized repairer, or any reliable repairer immediately if this occurs.

Brake Hold

The brake hold system keeps the brake applied when the shift lever is in D, M or N with the system on and the brake pedal has been depressed to stop the vehicle. The system releases the brake when the accelerator pedal is depressed with the shift lever in D or M to allow smooth start off.

Enabling the system

Turns the brake hold system on

The brake hold standby indicator **A** comes on. While the system is holding the brake, the brake hold operated indicator **B** comes on.

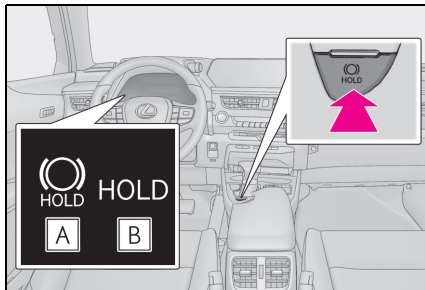

Brake hold system operating conditions

The brake hold system cannot be turned on in the following conditions:

- The driver's door is not closed.
- The driver is not wearing the seat belt.
- "Parking Brake Unavailable" or "EPB Malfunction Visit Your Dealer" is displayed on the multi-information display.

If any of the conditions above are detected when the brake hold system is enabled, the system will turn off and the brake hold

standby indicator light will go off. In addition, if any of the conditions are detected while the system is holding the brake, a warning buzzer will sound and a message will be shown on the multi-information display. The parking brake will then be set automatically.

Brake hold function

- If the brake pedal is left released for a period of about 3 minutes after the system has started holding the brake, the parking brake will be set automatically. In this case, a warning buzzer sounds and a message is shown on the multi-information display.
- To turn the system off while the system is holding the brake, firmly depress the brake pedal and press the button again.
- The brake hold function may not hold the vehicle when the vehicle is on a steep incline. In this situation, it may be necessary for the driver to apply the brakes. A warning buzzer will sound and the multi-information display will inform the driver of this situation. If a warning message is shown on the multi-information display, read the message and follow the instructions.

When the parking brake is set automatically while the system is holding the brakes

Perform any of the following operations to release the parking brake.

- Depress the accelerator pedal. (The parking brake will not be released automatically if the seat belt is not fastened.)
- Operate the parking brake switch with the brake pedal depressed. Make sure that the parking brake indicator light goes off. (→P.225)

When an inspection at any authorized Lexus retailer or Lexus authorized repairer, or any reliable repairer is necessary

When the brake hold standby indicator (green) does not illuminate even when the brake hold switch is pressed with the brake hold system operating conditions met, the

system may be malfunctioning. Have the vehicle inspected at any authorized Lexus retailer or Lexus authorized repairer, or any reliable repairer.

■ **If “Brake Hold Fault Depress Brake to Deactivate Visit Your Dealer” is displayed on the multi-information display**

The system may be malfunctioning. Have the vehicle inspected by any authorized Lexus retailer or Lexus authorized repairer, or any reliable repairer immediately.

■ **Warning messages and buzzers**

Warning messages and buzzers are used to indicate a system malfunction or to inform the driver of the need for caution. If a warning message is shown on the multi-information display, read the message and follow the instructions.

■ **If the brake hold operated indicator flashes**

→P.447



WARNING

■ **When the vehicle is on a steep incline**

When using the brake hold system on a steep incline, exercise caution. The brake hold function may not hold the vehicle in such a situation.

■ **When stopped on a slippery road**

The system cannot stop the vehicle when the gripping ability of the tires has been exceeded. Do not use the system when stopped on a slippery road.



NOTICE

■ **When parking the vehicle**

The brake hold system is not designed for use when parking the vehicle for a long period of time. Turning the engine switch off while the system is holding the brake may release the brake, which would cause the vehicle to move. When operating the engine switch, depress the brake pedal, shift the shift lever to P and set the parking brake.

ASC (Active Sound Control/Acceleration Sound Control)*

* : If equipped

The ASC system directs certain sounds from the front of the cabin to the vehicle interior, and harmonizes these sounds with the actual sound of the engine and exhaust in order to allow the driver to feel acceleration and the state of the engine more strongly.

control is set to "ECO").

Turning ASC system on

Press the ASC switch.

The indicator on the switch will turn on.

Press the ASC switch again to turn the ASC system off.

Even if the indicator is illuminated, when the driving mode (→P.337) is set to Eco drive mode or Custom mode (power/train control is set to "ECO"), ASC system does not operate.

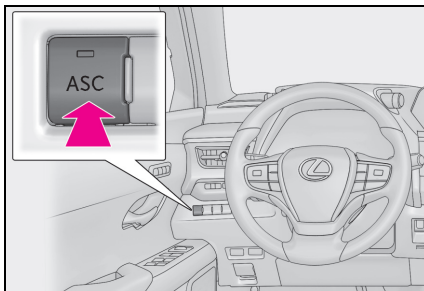

■ Operating conditions

The ASC system operates when the driving mode (→P.337) is set to other than Eco drive mode or Custom mode (power/train



Headlight switch

The headlights can be operated manually or automatically.

Turning on the headlights

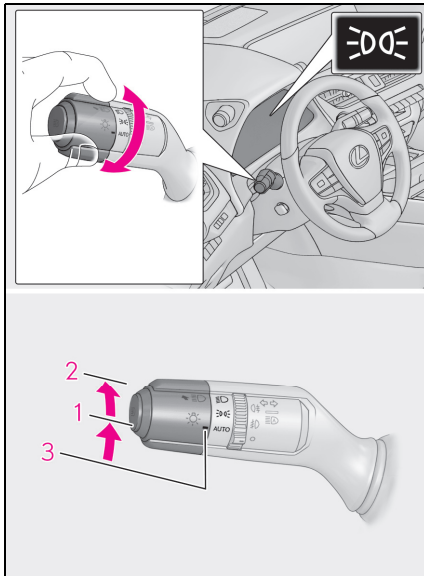
Operating the  switch turns on the lights as follows:



- 1  The front position, tail, license plate and instrument panel lights turn on.
- 2  The headlights and all the lights listed above turn on.
- 3 AUTO The headlights, daytime running lights (→P.231) and all the lights listed above turn on and off automatically.

■ AUTO mode can be used when

The engine switch is in ON.

■ Daytime running light function

To make your vehicle more visible to other drivers during daytime driving, the daytime running lights turn on automatically whenever the engine is started and the parking brake is released with the headlight switch in the AUTO position. (Illuminate brighter than the front position lights.) Daytime running lights are not designed for use at night.



■ Headlight control sensor

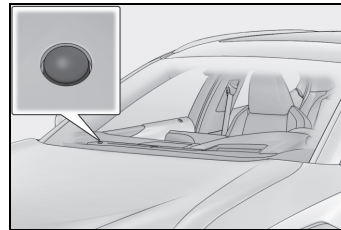

The sensor may not function properly if an object is placed on the sensor, or anything that blocks the sensor is affixed to the windshield.

Doing so interferes with the sensor detecting the level of ambient light and may cause the automatic headlight system to malfunction.



■ Automatic light off system

- When the light switch is in  or :
The headlights and front fog lights (if equipped) turn off automatically if the engine switch is turned to ACC or OFF.
- When the light switch is in AUTO position:
The headlights and all the lights turn off automatically if the engine switch is turned to ACC or OFF.

To turn the lights on again, turn the engine switch to ON, or turn the light switch to AUTO position once and then back to  or .

■ **Light reminder buzzer**

A buzzer sounds when the engine switch is turned off or turned to ACC and the driver's door is opened while the lights are turned on.

■ **Automatic headlight leveling system**

The level of the headlights is automatically adjusted according to the number of passengers and the loading condition of the vehicle to ensure that the headlights do not interfere with other road users.

■ **Battery-saving function**

In order to prevent the battery of the vehicle from discharging, if the light switch is in the  or AUTO position when the engine switch is turned off the battery saving function will operate and automatically turn off all the lights after approximately 20 minutes.

When the engine switch is turned to ON, the battery-saving function will be disabled.

When any of the following are performed, the battery-saving function is canceled once and then reactivated. All the lights will turn off automatically 20 minutes after the battery-saving function has been reactivated:

- When the headlight switch is operated
- When a door is opened or closed

■ **Welcome light illumination control**

The front position lights automatically turn on at night when the doors are unlocked using the entry function or wireless remote control if the light switch is in the AUTO position.

■ **Customization**

Settings (e.g. light sensor sensitivity) can be changed.
(Customizable features: →P.507)

 NOTICE

■ **To prevent battery discharge**

Do not leave the lights on longer than necessary when the engine is not running.

Turning on the high beam headlights

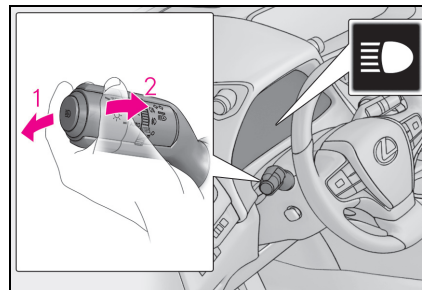

- 1 With the headlights on, push the lever away from you to turn on the high beams.

Pull the lever toward you to the center position to turn the high beams off.

- 2 Pull the lever toward you and release it to flash the high beams once.

You can flash the high beams with the headlights on or off.

Follow me home system

This system allows the headlights and front position lights to be turned on for 30 seconds when the engine switch is OFF.

Pull the lever toward you and release it with the light switch is in AUTO after turning the engine switch off.

Pull the lever toward you and release it

again to turn off the lights.

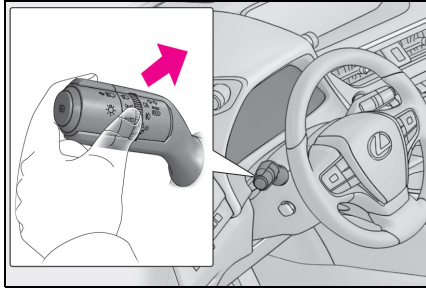

Cornering lights (if equipped)

When any of the following conditions is met, while the headlights (low beam) are on, the cornering lights will additionally turn on and light up the direction of movement for the vehicle. This is to ensure excellent visibility when either driving at intersections or parking at night.

- The steering wheel is operated
- The turn signal lever is operated
- The shift lever is in R (both left and right side cornering lights)

■ Cornering light control

- The lights illuminate when the vehicle speed is approximately 30 km/h (19 mph) or less. However, the lights turn off when the vehicle speed increases to approximately 35 km/h (22 mph) or more.
- After the lights remain illuminated for 30 minutes, they automatically turn off.

AHS (Adaptive High-beam System)*

*: If equipped

The Adaptive High-beam System uses a front camera located behind the upper portion of the windshield to assess the brightness of the lights of vehicles ahead, streetlights, etc., and automatically controls the headlight light distribution as necessary.

⚠ WARNING

■ Limitations of the Adaptive High-beam System

Do not overly rely on the Adaptive High-beam System. Always drive safely, taking care to observe your surroundings and turning the high beams on or off manually if necessary.

■ To prevent incorrect operation of the Adaptive High-beam System

Do not overload the vehicle.

System functions

- Adjusts the brightness and illuminated area of the high beams according to the vehicle speed.
- Adjusts the intensity of the high beams, while driving on a curve, so that the area in the direction that the vehicle is turning will be illuminated more brightly than other areas.
- Operates the shaded high beams so that the area around vehicles ahead is partially not illuminated while all other areas continue to be illumi-

nated with the high beams.

The shaded high beams help optimize forward visibility while reducing the dazzling effect on the drivers of vehicles ahead.

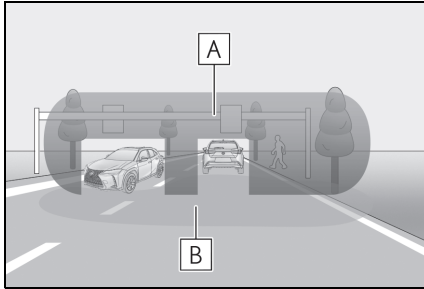

A Illuminated area of the high beams

B Illuminated area of the low beams

- Adjusts the distance that the low beams are projected according to the distance to a preceding vehicle.
- When driving at low speeds, the cornering lights will illuminate the area around both front corners of the vehicle.

Activating the Adaptive High-beam System

- 1 Press the Adaptive High-beam System switch.

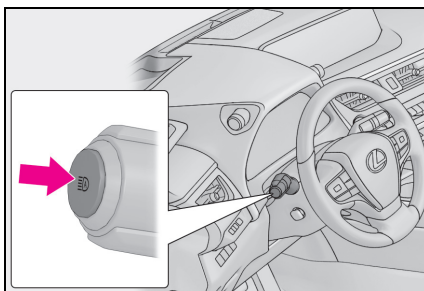

- 2 Turn the headlight switch to the  or AUTO position.

The AHS indicator will come on when the system is operating.

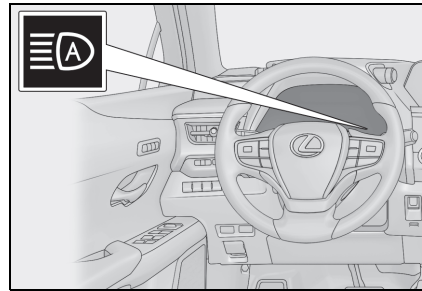

Operating conditions of the Adaptive High-beam System

- When all of the following conditions are met, the high beams will be turned on automatically and the system will operate:
 - The vehicle speed is approximately 60 km/h (38 mph) or more.*
 - The area ahead of the vehicle is dark.
- *: When the vehicle speed is approximately 60 km/h (38 mph) or more, the area in the direction that the vehicle is turning will be illuminated more brightly than other areas while driving on a curve.
- When all of the following conditions are met, the shaded high beams will turn on and the distance that the low beams are projected will be adjusted automatically, depending on the location of vehicles ahead:
 - The vehicle speed is approximately 60 km/h (38 mph) or more.
 - The area ahead of the vehicle is dark.
 - There are vehicles ahead with headlights or tail lights turned on.
- If any of the following conditions are met, the high beams or shaded high beams will be changed to the low beams automatically:
 - The vehicle speed is below approximately 60 km/h (38 mph).
 - The area ahead of the vehicle is not dark.

- There are many vehicles ahead.
- When the vehicle speed is between approximately 3 and 15 km/h (1.9 and 9.3 mph), the cornering lights will turn on.
- **Front camera detection information**
- The high beams may not be automatically changed to the shaded high beams in the following situations:
 - When vehicles ahead suddenly appear from a curve
 - When the vehicle is cut in front of by another vehicle
 - When vehicles ahead are hidden from sight due to repeated curves, road dividers or roadside trees
 - When vehicles ahead appear from the faraway lane on wide road
 - When vehicles ahead have no lights
- The high beams may be changed to the shaded high beams if a vehicle ahead that is using fog lights without its headlights turned on is detected.
- House lights, street lights, traffic signals, and illuminated billboards or signs and other reflective objects may cause the high beams to change to the shaded high beams, cause the high beams not to change to the shaded high beams, or change the area that is not illuminated.
- The following factors may affect the amount of time taken to turn the high beam on or off, or the speed by which the areas not illuminated change:
 - The brightness of headlights, fog lights, and tail lights of vehicles ahead
 - The movement and direction of vehicles ahead
 - When a vehicle ahead only has operational lights on one side
 - When a vehicle ahead is a two-wheeled vehicle
 - The condition of the road (gradient, curve, condition of the road surface etc.)
 - The number of passengers and amount of luggage
- The light distribution control of the headlights may change unexpectedly.
- Bicycles or similar objects may not be detected.
- In the following situations the system may not be able to correctly detect the surrounding brightness level. This may cause the low beams to remain on or the high beams to flash or dazzle pedestrians or vehicles ahead. In such a case, it is necessary to manually switch between the high and low beams.
 - When driving in inclement weather (heavy rain, snow, fog, sandstorms, etc.)
 - When the windshield is obscured by fog, mist, ice, dirt, etc.
 - When the windshield is cracked or damaged
 - When the front camera is deformed or dirty
 - When the temperature of the front camera is extremely high
 - When the surrounding brightness level is equal to that of headlights, tail lights or fog lights
 - When headlights or tail lights of vehicles ahead are turned off, dirty, changing color, or not aimed properly
 - When the vehicle is hit by water, snow, dust, etc. from a preceding vehicle
 - When driving through an area of intermittently changing brightness and darkness
 - When frequently and repeatedly driving ascending/descending roads, or roads with rough, bumpy or uneven surfaces (such as stone-paved roads, gravel roads, etc.)
 - When frequently and repeatedly taking curves or driving on a winding road
 - When there is a highly reflective object ahead of the vehicle, such as a sign or mirror
 - When the back of a preceding vehicle is highly reflective, such as a container on a truck
 - When the vehicle's headlights are damaged or dirty, or are not aimed properly
 - When the vehicle is listing or tilting due to a flat tire, a trailer being towed, etc.
 - When the headlights are changed between the high beams and low beams repeatedly in an abnormal manner
 - When the driver believes that the high beams may be flashing or dazzling pedestrians or other drivers
 - When the vehicle is used in an area in

which vehicles travel on the opposite side of the road of the country for which the vehicle was designed, for example using a vehicle designed for right-hand traffic in a left-hand traffic area, or vice versa

- When going through the Straits of Dover.

■ **Customization**

Some functions can be customized.
(→P.508)

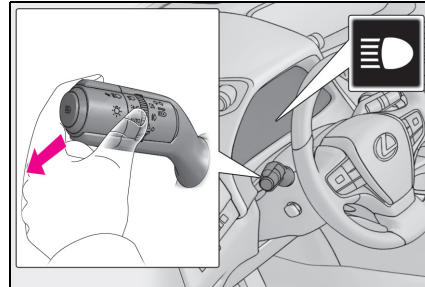

Turning the high beams on/off manually

■ **Switching to the low beams**

Press the Adaptive High-beam System switch.

The AHS indicator will turn off.

Press the switch to activate the Adaptive High-beam System again.

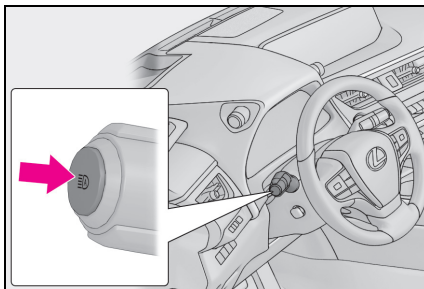

■ **Switching to the high beams**

Push the lever away from you.

The AHS indicator will turn off and the high beam indicator will turn on.

Pull the lever to its original position to activate the Adaptive High-beam System again.

■ **Switching to the high beams temporarily**

The high beams are turned on while the lever is pulled toward you. Returning the lever to its original position turns the low beams on. A while after the low beams are turned on, the Adaptive High-beam System will be activated again.

Automatic High Beam *

*: If equipped

The Automatic High Beam uses a front camera located behind the upper portion of the windshield to assess the brightness of the lights of vehicles ahead, streetlights, etc., and automatically turns the high beams on or off as necessary.

⚠ WARNING

■ Limitations of the Automatic High Beam

Do not overly rely on the Automatic High Beam. Always drive safely, taking care to observe your surroundings and turning the high beams on or off manually if necessary.

■ To prevent incorrect operation of the Automatic High Beam system

Do not overload the vehicle.

Activating the Automatic High Beam

- 1 Press the Automatic High Beam switch.

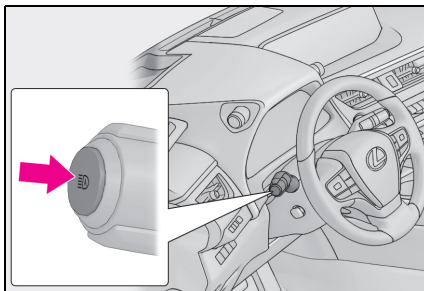

- 2 Turn the headlight switch to the  or AUTO position.

The Automatic High Beam indicator will come on when the system is operating.

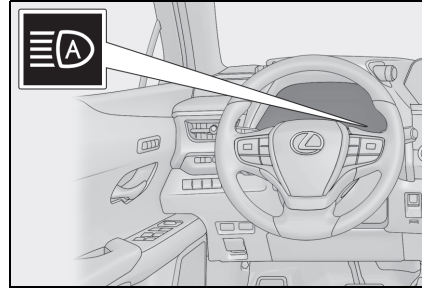

■ Conditions to turn the high beams on/off automatically

- When all of the following conditions are met, the high beams will be turned on automatically (after approximately 1 second):
 - The vehicle speed is approximately 40 km/h (25 mph) or more.
 - The area ahead of the vehicle is dark.
 - There are no vehicles ahead with headlights or tail lights turned on.
 - There are few streetlights on the road ahead.
- If any of the following conditions are met, the high beams will turn off automatically:
 - The vehicle speed is below approximately 30 km/h (19 mph).
 - The area ahead of the vehicle is not dark.
 - Vehicles ahead have their headlights or tail lights turned on.
 - There are many streetlights on the road ahead.

■ Front camera detection information

- The high beams may not be automatically turned off in the following situations:
 - When a vehicle suddenly appears from around a curve
 - When the vehicle is cut in front of by another vehicle
 - When vehicles ahead cannot be detected due to repeated curves, road dividers or roadside trees
 - When vehicles ahead appear in a far-away lane on a wide road
 - When the lights of vehicles ahead are not on

- The high beams may be turned off if a vehicle ahead that is using fog lights without its headlights turned on is detected.
- House lights, street lights, traffic signals, and illuminated billboards or signs and other reflective objects may cause the high beams to change to the low beams, or the low beams to remain on.
- The following factors may affect the amount of time taken for the high beams to turn on or off:
 - The brightness of the headlights, fog lights, and tail lights of vehicles ahead
 - The movement and direction of vehicles ahead
 - When a vehicle ahead only has operational lights on one side
 - When a vehicle ahead is a two-wheeled vehicle
 - The condition of the road (gradient, curve, condition of the road surface, etc.)
 - The number of passengers and amount of luggage in the vehicle
- The high beams may turn on or off unexpectedly.
- Bicycles or similar vehicles may not be detected.
- In the following situations the system may not be able to correctly detect the surrounding brightness level. This may cause the low beams to remain on or the high beams to flash or dazzle pedestrians or vehicles ahead. In such a case, it is necessary to manually switch between the high and low beams.
 - When driving in inclement weather (heavy rain, snow, fog, sandstorms, etc.)
 - When the windshield is obscured by fog, mist, ice, dirt, etc.
 - When the windshield is cracked or damaged
 - When the front camera is deformed or dirty
 - When the temperature of the front camera is extremely high
 - When the surrounding brightness level is equal to that of headlights, tail lights or fog lights
 - When headlights or tail lights of vehicles ahead are turned off, dirty, changing color, or not aimed properly
- When the vehicle is hit by water, snow, dust, etc. from a preceding vehicle
- When driving through an area of intermittently changing brightness and darkness
- When frequently and repeatedly driving ascending/descending roads, or roads with rough, bumpy or uneven surfaces (such as stone-paved roads, gravel roads, etc.)
- When frequently and repeatedly taking curves or driving on a winding road
- When there is a highly reflective object ahead of the vehicle, such as a sign or mirror
- When the back of a preceding vehicle is highly reflective, such as a container on a truck
- When the vehicle's headlights are damaged or dirty, or are not aimed properly
- When the vehicle is listing or tilting due to a flat tire, a trailer being towed, etc.
- When the headlights are changed between the high beams and low beams repeatedly in an abnormal manner
- When the driver believes that the high beams may be flashing or dazzling pedestrians or other drivers
- When the vehicle is used in an area in which vehicles travel on the opposite side of the road of the country for which the vehicle was designed, for example using a vehicle designed for right-hand traffic in a left-hand traffic area, or vice versa
- When going through the Straits of Dover.

Turning the high beams on/off manually

■ Switching to the low beams

Press the Automatic High Beam switch.

The Automatic High Beam indicator will turn off.

Press the switch to activate the Automatic High Beam system again.

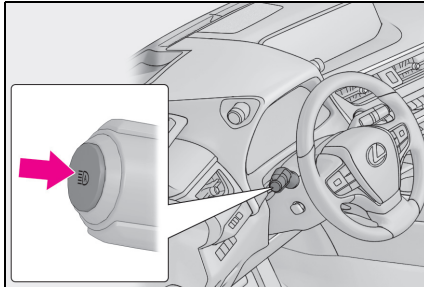

■ Switching to the high beams

Push the lever away from you.

The Automatic High Beam indicator will turn off and the high beam indicator will turn on.

Pull the lever to its original position to activate the Automatic High Beam system again.

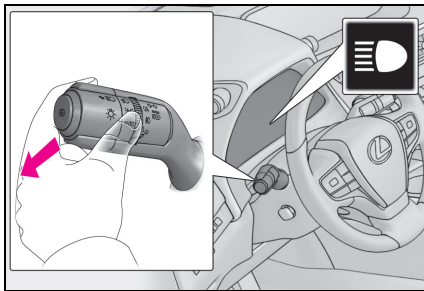

■ Switching to the high beams temporarily

The high beams are turned on during the lever is pulled toward you. Returning the lever to its original position turns the low beams on. A while after the low beams are turned on, the Automatic High Beam system will be activated again.

Fog light switch

When in difficult driving conditions, such as in rain and fog, turn on the front fog lights to secure front visibility and turn on the rear fog lights to notify following vehicles the existence of your vehicle.

Turning on the fog lights

► Rear fog light switch

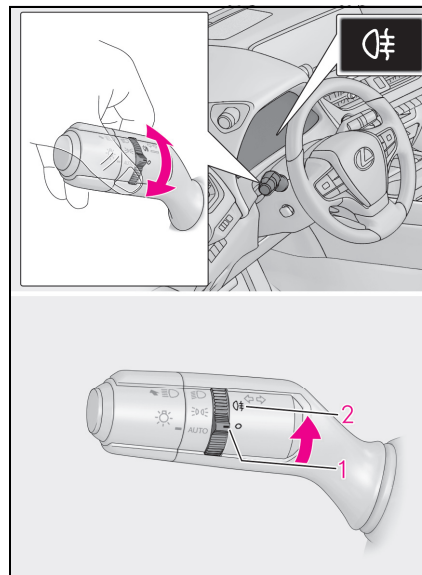

1 ○ Turns the rear fog lights off

2 ☁ Turns the rear fog lights on

Releasing the switch ring returns it to



Operating the switch ring again turns the rear fog lights off.

▶ Front and rear fog light switch

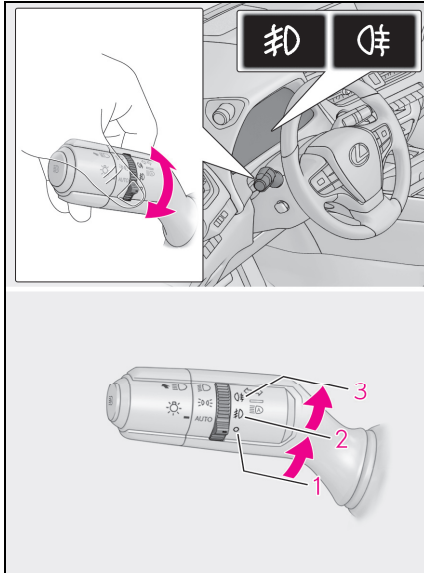

- 1 ○ Turns the front and rear fog lights off
- 2 和 Turns the front fog lights on
- 3 和 Turns the both front and rear fog lights on

Releasing the switch ring returns it to

和 .

Operating the switch ring again turns only the rear lights off.

 NOTICE

■ To prevent battery discharge

Do not leave the lights on longer than necessary when the engine is off.

■ Fog lights can be used when

- ▶ Vehicles with rear fog lights only

The headlights are turned on.

- ▶ Vehicles with front and rear fog lights

Front fog lights: The front position lights are turned on.

Rear fog lights: The front fog lights are turned on.

Windshield wipers and washer

Operating the lever can change wiper operation to automatic/manual or squirt washer fluid.

NOTICE

■ When the windshield is dry

Do not use the wipers, as they may damage the windshield.

Operating the wiper lever

Operating the  lever operates the wipers or washer as follows:

- ▶ Intermittent windshield wipers with interval adjuster

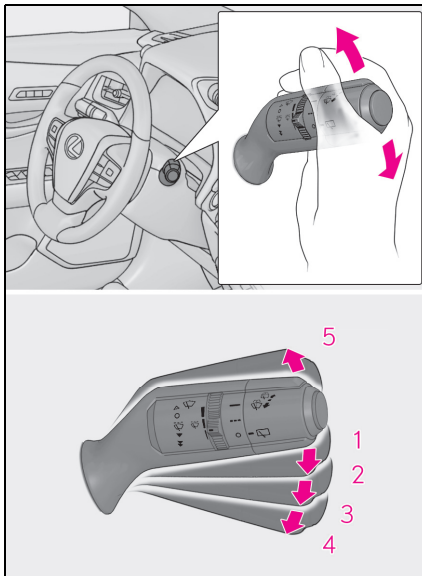

- 1 ○ Off
- 2  Intermittent operation

- 3 ▼ Low speed operation
- 4 ▾ High speed operation
- 5 ▲ Temporary operation

Wiper intervals can be adjusted when intermittent operation is selected.

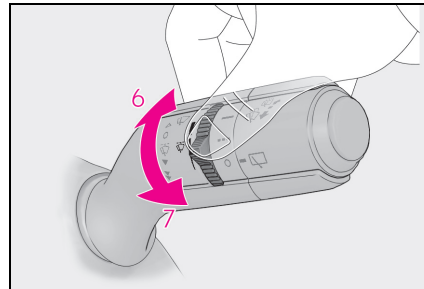

- 6 Increases the intermittent windshield wiper frequency
- 7 Decreases the intermittent windshield wiper frequency

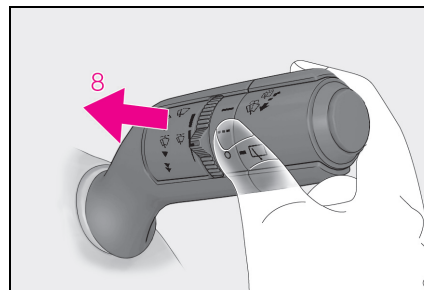

- 8  Washer/wiper dual operation

Pulling the lever operates the wipers and washer.

The wipers will automatically operate a couple of times after the washer squirts. Vehicles with headlight cleaners: When the engine switch is in ON and the headlights are on, if the lever is pulled, the headlight cleaners will operate once. After this, the headlight cleaners will operate every 5th

time the lever is pulled.

► Rain-sensing windshield wipers

When AUTO is selected, the wipers will operate automatically when the sensor detects falling rain. The system automatically adjusts wiper timing in accordance with rain volume and vehicle speed.

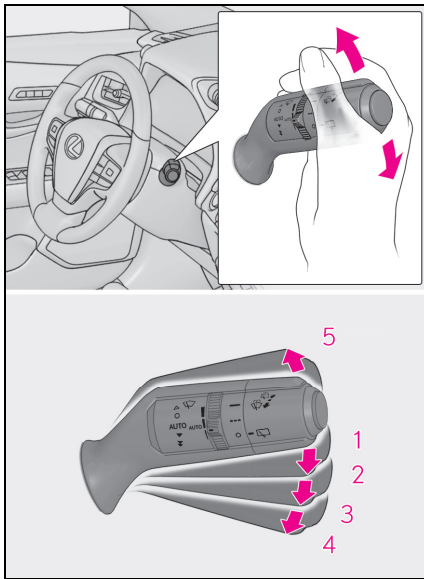

- 1 ○ Off
- 2 AUTO Rain-sensing operation
- 3 ▼ Low speed operation
- 4 ▼ High speed operation
- 5 ▲ Temporary operation

When AUTO is selected, the sensor sensitivity can be adjusted by turning the switch ring.

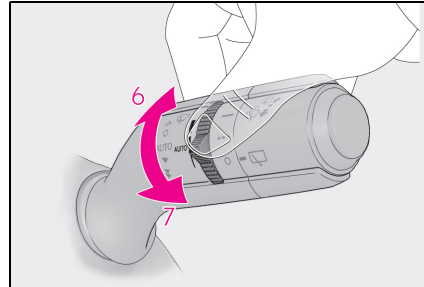

- 6 Increases the sensitivity
- 7 Decreases the sensitivity

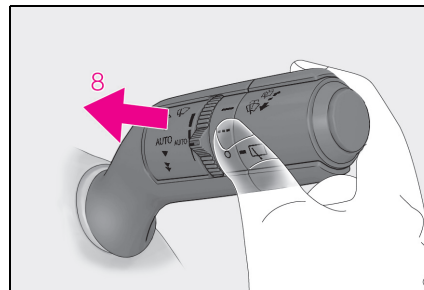

8 Washer/wiper dual operation

Pulling the lever operates the wipers and washer.

The wipers will automatically operate a couple of times after the washer squirts. (After operating several times, the wipers operate once more time after a short delay to prevent dripping. However, the dripping prevention does not operate while the vehicle is moving.)

Vehicles with headlight cleaners: When the engine switch is in ON and the headlights are on, if the lever is pulled, the headlight cleaners will operate once. After this, the headlight cleaners will operate every 5th time the lever is pulled.

■ The windshield wipers and washer can be operated when
The engine switch is in ON.

■ **Effects of vehicle speed on wiper operation (vehicles with rain-sensing windshield wipers)**

Vehicle speed affects the Intermittent wiper interval.

■ **Raindrop sensor (vehicles with rain-sensing windshield wipers)**

- The raindrop sensor judges the amount of raindrops.
An optical sensor is adopted. It may not operate properly when sunlight from the rising or setting of the sun intermittently strikes the windshield, or if bugs, etc. are present on the windshield.

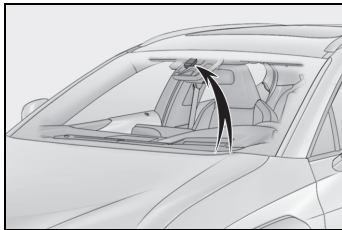

- If the wiper switch is turned to the "AUTO" position while the engine switch is in ON, the wipers will operate once to show that AUTO mode is activated.
- If the temperature of the raindrop sensor is 90°C (194°F) or higher, or -15°C (5°F) or lower, automatic operation may not occur. In this case, operate the wipers in any mode other than AUTO mode.

■ **If no windshield washer fluid sprays**

Check that the washer nozzles are not blocked, if there is washer fluid in the washer fluid tank.

⚠ WARNING

■ **Caution regarding the use of windshield wipers in AUTO mode (vehicles with rain-sensing windshield wipers)**

The windshield wipers may operate unexpectedly if the sensor is touched or the windshield is subject to vibration in AUTO mode. Take care that your fingers, etc. do not become caught in the windshield wipers.

■ **Caution regarding the use of washer fluid**

When it is cold, do not use the washer fluid until the windshield becomes warm. The fluid may freeze on the windshield and cause low visibility. This may lead to an accident, resulting in death or serious injury.

⚠ NOTICE

■ **When the washer fluid tank is empty**

Do not operate the switch continually as the washer fluid pump may overheat.

■ **When a nozzle becomes blocked**

In this case, contact any authorized Lexus retailer or Lexus authorized repairer, or any reliable repairer. Do not try to clear it with a pin or other object. The nozzle will be damaged.

■ **To prevent battery discharge**

Do not leave the wipers on longer than necessary when the engine is off.

Changing the windshield wiper rest position/Lifting the windshield wipers

When the windshield wipers are not being used, they retract to below the hood. To enable the windshield wipers to be lifted when parking in cold condi-

tions or when replacing a windshield wiper insert, change the rest position of the windshield wipers to the service position using the wiper lever.

■ **Raising the wipers to the service position**

Within approximately 45 seconds of turning the engine switch off, move the

wiper lever to the Δ position and hold it for approximately 2 seconds or more.

The wipers will move to the service position.

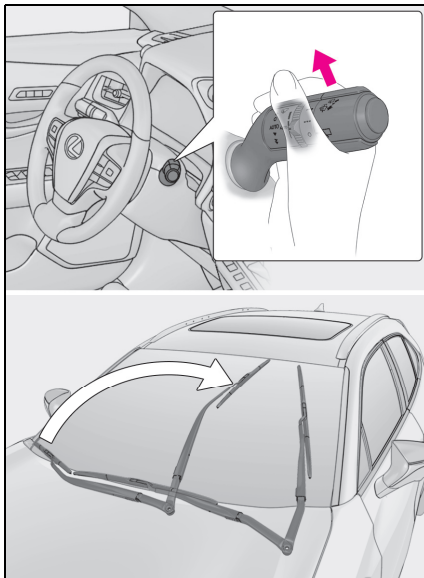

■ **Lifting the windshield wipers**

While holding the hook portion **A** of the wiper arm, lift the windshield wiper from the windshield.

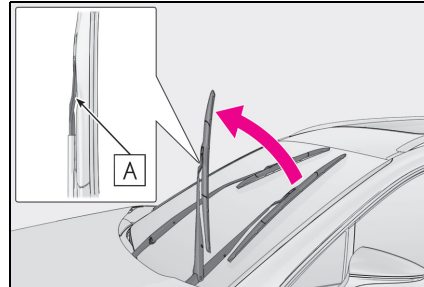

■ **Lowering the windshield wipers to the retracted position**

With the windshield wipers placed on the windshield, turn the engine switch to ON and then move the wiper lever to an operating position. When the wiper switch is turned off, the windshield wipers will stop at the retracted position. Even if the wipers deviate while the engine switch is OFF, the wipers will return to the normal position.

 **NOTICE**

■ **When lifting the windshield wipers**

- Do not lift the windshield wipers when they are in the retracted position below the hood. Otherwise, they may contact the hood, possibly resulting in damage to a windshield wiper and/or the hood.
- Do not lift a windshield wiper by the wiper blade. Otherwise, the wiper blade may be deformed.

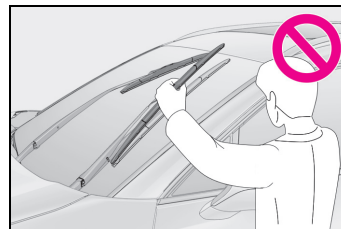

**NOTICE**

- Do not operate the wiper lever when the windshield wipers are lifted. Otherwise, the windshield wipers may contact the hood, possibly resulting in damage to the windshield wipers and/or hood.

Rear window wiper and washer

The rear window wiper and washer can be used by operating the lever.

**NOTICE**

- **When the rear window is dry**
Do not use the wiper, as it may damage the rear window.

Operating the wiper lever

Operating the  switch operates the rear wiper as follows:

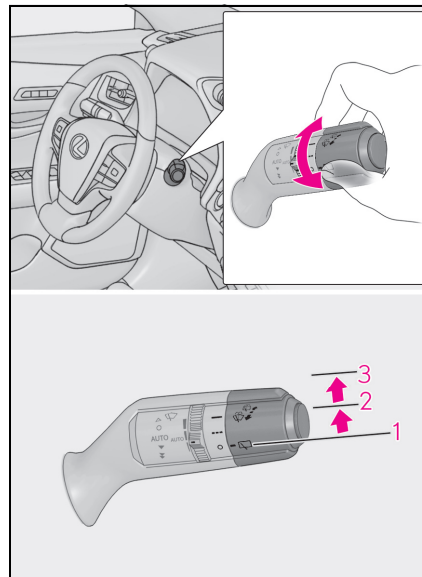

- 1 ○ Off
- 2 - - - Intermittent operation
- 3 — Normal operation

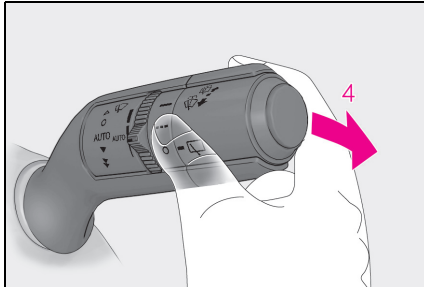

4  Washer/wiper dual operation

Pushing the lever operates the wiper and washer.

The wipers will automatically operate a couple of times after the washer squirts.

■ **The rear window wiper and washer can be operated when**

The engine switch is in ON.

■ **If no windshield washer fluid sprays**

Check that the washer nozzles are not blocked, if there is washer fluid in the washer fluid tank.

■ **Reverse-linked rear window wiper function**

When the shift lever is shifted to R when the front wipers are operating, the rear window wiper will operate once.

■ **Back door opening linked rear window wiper stop function**

When the rear window wiper is operating, if the back door is opened while the vehicle is stopped, operation of the rear window wiper will be stopped to prevent anyone near the vehicle from being sprayed by water from the wiper. When the back door is closed, wiper operation will resume.*

*: The setting must be customized at any authorized Lexus retailer or Lexus authorized repairer, or any reliable repairer.

■ **Customization**

Setting of the reverse-linked function can

be changed. (Customizable features: →P.507)

 NOTICE

■ **When the washer fluid tank is empty**

Do not operate the switch continually as the washer fluid pump may overheat.

■ **When a nozzle becomes blocked**

In this case, contact any authorized Lexus retailer or Lexus authorized repairer, or any reliable repairer. Do not try to clear it with a pin or other object. The nozzle will be damaged.

■ **To prevent battery discharge**

Do not leave the wipers on longer than necessary when the engine is off.

Opening the fuel tank cap

Before refueling the vehicle

- Turn the engine switch off and ensure that all the doors and windows are closed.
- Confirm the type of fuel.

■ **Fuel types**

→P.499

■ **Fuel tank opening for unleaded gasoline**

To help prevent incorrect fueling, your vehicle has a fuel tank opening that only accommodates the special nozzle on unleaded fuel pumps.

 **WARNING**

■ **When refueling the vehicle**

Observe the following precautions while refueling the vehicle. Failure to do so may result in death or serious injury.

- After exiting the vehicle and before opening the fuel door, touch an unpainted metal surface to discharge any static electricity. It is important to discharge static electricity before refueling because sparks resulting from static electricity can cause fuel vapors to ignite while refueling.
- Always hold the grips on the fuel tank cap and turn it slowly to remove it. A whooshing sound may be heard when the fuel tank cap is loosened. Wait until the sound cannot be heard before fully removing the cap. In hot weather, pressurized fuel may spray out the filler neck and cause injury.
- Do not allow anyone that has not discharged static electricity from their body to come close to an open fuel tank.

- Do not inhale vaporized fuel. Fuel contains substances that are harmful if inhaled.
- Do not smoke while refueling the vehicle. Doing so may cause the fuel to ignite and cause a fire.
- Do not return to the vehicle or touch any person or object that is statically charged. This may cause static electricity to build up, resulting in a possible ignition hazard.

■ **When refueling**

Observe the following precautions to prevent fuel overflowing from the fuel tank:

- Securely insert the fuel nozzle into the fuel filler neck.
- Stop filling the tank after the fuel nozzle automatically clicks off.
- Do not top off the fuel tank.

 **NOTICE**

■ **Refueling**

Do not spill fuel during refueling. Doing so may damage the vehicle, such as causing the emission control system to operate abnormally or damaging fuel system components or the vehicle's painted surface.

Opening the fuel tank cap

- 1 Press the opener switch.

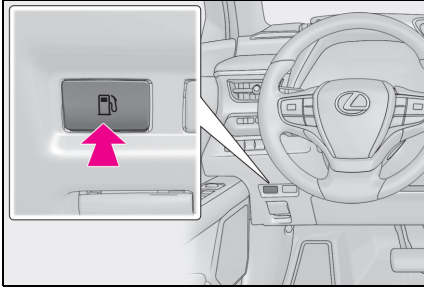

- 2 Turn the fuel tank cap slowly and remove it, then put it into the holder on the fuel filler door.

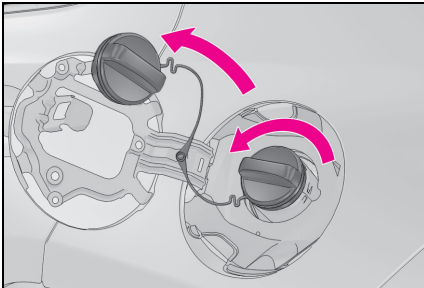

■ If the fuel filler door cannot be opened
→P.479

Closing the fuel tank cap

After refueling, turn the fuel tank cap until you hear a click. Once the cap is released, it will turn slightly in the opposite direction.

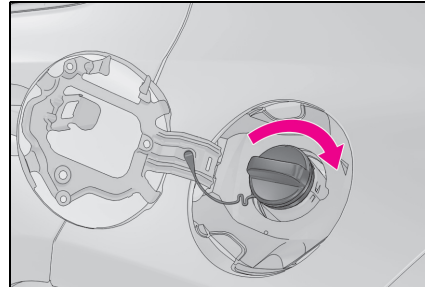

⚠ WARNING

■ When replacing the fuel tank cap

Do not use anything but a genuine Lexus fuel tank cap designed for your vehicle. Doing so may cause a fire or other incident which may result in death or serious injury.

Lexus Safety System+*

*: If equipped

The Lexus Safety System+ consists of the following drive assist systems and contributes to a safe and comfortable driving experience:

Driving assist system

- PCS (Pre-Collision System)

→P.260

- LTA (Lane Tracing Assist)

→P.268

- AHS (Adaptive High-beam System)*

→P.233

- Automatic High Beam*

→P.237

- RSA (Road Sign Assist)

→P.277

- Dynamic radar cruise control with full-speed range

→P.281

*: If equipped

! WARNING

■ Lexus Safety System+

The Lexus Safety System+ is designed to operate under the assumption that the driver will drive safely, and is designed to help reduce the impact to the occupants and the vehicle in the case of a collision or assist the driver in normal driving conditions.

As there is a limit to the degree of recognition accuracy and control performance that this system can provide, do not overly rely on this system. The driver is always responsible for paying attention to the vehicle's surroundings and driving safely.

Sensors

Two types of sensors, located behind the front grille and windshield, detect information necessary to operate the drive assist systems.

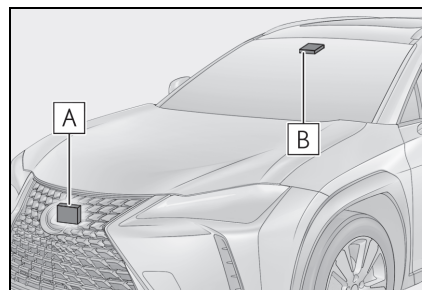

A Radar sensor

B Front camera

⚠ WARNING

■ **To avoid malfunction of the radar sensor**

Observe the following precautions. Otherwise, the radar sensor may not operate properly, possibly leading to an accident resulting in death or serious injury.

- Keep the radar sensor and the grille cover clean at all times.

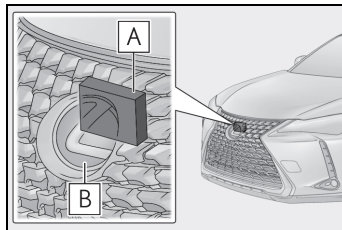

A Radar sensor

B Grille cover

If the front of the radar sensor or the front or back of the grille cover is dirty or covered with water droplets, snow, etc., clean it.

Clean the radar sensor and grille cover with a soft cloth to avoid damaging them.

- Do not attach accessories, stickers (including transparent stickers) or other items to the radar sensor, grille cover or surrounding area.
- Do not subject the radar sensor or its surrounding area to a strong impact. If the radar sensor, front grille, or front bumper has been subjected to a strong impact, have the vehicle inspected by any authorized Lexus retailer or Lexus authorized repairer, or any reliable repairer.
- Do not disassemble the radar sensor.
- Do not modify or paint the radar sensor or grille cover.

- If the radar sensor, front grille, or front bumper needs to be removed and installed, or replaced, contact any authorized Lexus retailer or Lexus authorized repairer, or any reliable repairer.

■ **To avoid malfunction of the front camera**

Observe the following precautions. Otherwise, the front camera may not operate properly, possibly leading to an accident resulting in death or serious injury.

- Keep the windshield clean at all times.
 - If the windshield is dirty or covered with an oily film, water droplets, snow, etc., clean the windshield.
 - If a glass coating agent is applied to the windshield, it will still be necessary to use the windshield wipers to remove water droplets, etc. from the area of the windshield in front of the front camera.
 - If the inner side of the windshield where the front camera is installed is dirty, contact any authorized Lexus retailer or Lexus authorized repairer, or any reliable repairer.

⚠ WARNING

- Do not attach objects, such as stickers, transparent stickers, etc., to the outer side of the windshield in front of the front camera (shaded area in the illustration).

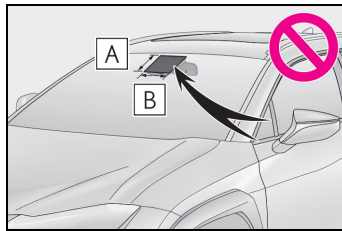

- A** From the top of the windshield to approximately 1 cm (0.4 in.) below the bottom of the front camera
 - B** Approximately 20 cm (7.9 in.) (Approximately 10 cm [4.0 in.] to the right and left from the center of the front camera)
- If the part of the windshield in front of the front camera is fogged up or covered with condensation, or ice, use the windshield defogger to remove the fog, condensation, or ice. (→P.357)
 - If water droplets cannot be properly removed from the area of the windshield in front of the front camera by the windshield wipers, replace the wiper insert or wiper blade. If the wiper inserts or wiper blades need to be replaced, contact any authorized Lexus retailer or Lexus authorized repairer, or any reliable repairer.
 - Do not attach window tint to the windshield.

- Replace the windshield if it is damaged or cracked.
If the windshield needs to be replaced, contact any authorized Lexus retailer or Lexus authorized repairer, or any reliable repairer.
- Do not allow liquids to contact the front camera.
- Do not allow bright lights to shine into the front camera.
- Do not dirty or damage the front camera.
When cleaning the inside of the windshield, do not allow glass cleaner to contact the lens of the front camera. Also, do not touch the lens.
If the lens is dirty or damaged, contact any authorized Lexus retailer or Lexus authorized repairer, or any reliable repairer.
- Do not subject the front camera to a strong impact.
- Do not change the installation position or direction of the front camera or remove it.
- Do not disassemble the front camera.
- Do not modify any components of the vehicle around the front camera (inside rear view mirror, etc.) or ceiling.
- Do not attach any accessories to the hood, front grille or front bumper that may obstruct the front camera. Contact any authorized Lexus retailer or Lexus authorized repairer, or any reliable repairer for details.
- If a surfboard or other long object is to be mounted on the roof, make sure that it will not obstruct the front camera.
- Do not modify the headlights or other lights.

■ Certification

<p>Transmitter: Model: DNMWR009 Operation frequency: 76.5 GHz Maximum output power: 416.87 mW or less Manufacturer: DENSO CORPORATION Address: 1-1, Showa-cho, Kariya-shi, Aichi-ken, 448-8661 Japan</p>	
<p>Hereby, DENSO CORPORATION declares that the radio equipment type is in compliance with Directive 2014/53/EU. The full text of the EU declaration of conformity is available at the following internet address: https://www.denso.com/global/en/contact-us/doc/</p>	01
<p>DENSO CORPORATION vakuuttaa, että radiolaitetyyppi on direktiivin 2014/53/EU mukainen. EU-vaatimustenmukaisuusvakuutuksen täysimittainen teksti on saatavilla seuraavassa internetosoitteessa: https://www.denso.com/global/en/contact-us/doc/</p>	02
<p>Hierbij verklaar ik, DENSO CORPORATION, dat het type radioapparatuur conform is met Richtlijn 2014/53/EU. De volledige tekst van de EU-conformiteitsverklaring kan worden geraadpleegd op het volgende internetadres: https://www.denso.com/global/en/contact-us/doc/</p>	03
<p>Le soussigné, DENSO CORPORATION, déclare que l'équipement radioélectrique du type est conforme à la directive 2014/53/UE. Le texte complet de la déclaration UE de conformité est disponible à l'adresse internet suivante: https://www.denso.com/global/en/contact-us/doc/</p>	04

<p>Härmed försäkrar DENSO CORPORATION att denna typ av radioutrustning överensstämmer med direktiv 2014/53/EU. Den fullständiga texten till EU-försäkran om överensstämmelse finns på följande webbadress: https://www.denso.com/global/en/contact-us/doc/</p>	05
<p>Hermed erklærer DENSO CORPORATION, at radioudstyrstypen er i overensstemmelse med direktiv 2014/53/EU. EU-overensstemmelseserklæringens fulde tekst kan findes på følgende internetadresse: https://www.denso.com/global/en/contact-us/doc/</p>	06
<p>Hiermit erklärt DENSO CORPORATION, dass der Funkanlagentyp der Richtlinie 2014/53/EU entspricht. Der vollständige Text der EU-Konformitätserklärung ist unter der folgenden Internetadresse verfügbar: https://www.denso.com/global/en/contact-us/doc/</p>	07
<p>Με την παρούσα ο/η DENSO CORPORATION, δηλώνει ότι ο ραδιοεξοπλισμός πληροί την οδηγία 2014/53/ΕΕ. Το πλήρες κείμενο της δήλωσης συμμόρφωσης ΕΕ διατίθεται στην ακόλουθη ιστοσελίδα στο διαδίκτυο: https://www.denso.com/global/en/contact-us/doc/</p>	08
<p>Il fabbricante, DENSO CORPORATION, dichiara che il tipo di apparecchiatura radio è conforme alla direttiva 2014/53/UE. Il testo completo della dichiarazione di conformità UE è disponibile al seguente indirizzo Internet: https://www.denso.com/global/en/contact-us/doc/</p>	09

<p>Por la presente, DENSO CORPORATION declara que el tipo de equipo radioeléctrico es conforme con la Directiva 2014/53/UE. El texto completo de la declaración UE de conformidad está disponible en la dirección Internet siguiente: https://www.denso.com/global/en/contact-us/doc/</p>	10
<p>O(a) abaixo assinado(a) DENSO CORPORATION declara que o presente tipo de equipamento de rádio está em conformidade com a Diretiva 2014/53/UE. O texto integral da declaração de conformidade está disponível no seguinte endereço de Internet: https://www.denso.com/global/en/contact-us/doc/</p>	11
<p>B'dan, DENSO CORPORATION, niddikjara li dan it-tip ta' tagħmir tar-radju huwa konformi mad-Direttiva 2014/53/UE. It-test kollu tad-dikjarazzjoni ta' konformità tal-UE huwa disponibbli f'dan l-indirizz tal-Internet li ġej: https://www.denso.com/global/en/contact-us/doc/</p>	12
<p>Käesolevaga deklareerib DENSO CORPORATION, et käesolev raadioseadme tüüp vastab direktiivi 2014/53/EL nõuetele. ELi vastavusdeklaratsiooni täielik tekst on kättesaadav järgmisel internetiaadressil: https://www.denso.com/global/en/contact-us/doc/</p>	13
<p>DENSO CORPORATION igazolja, hogy a típusú rádióberendezés megfelel a 2014/53/EU irányelvnek. Az EU-megfelelőségi nyilatkozat teljes szövege elérhető a következő internetes címen: https://www.denso.com/global/en/contact-us/doc/</p>	14

DENSO CORPORATION týmto vyhlasuje, že rádiové zariadenie typu je v súlade so smernicou 2014/53/EÚ. Úplné EÚ vyhlásenie o zhode je k dispozícii na tejto internetovej adrese: https://www.denso.com/global/en/contact-us/doc/	15
Týmto DENSO CORPORATION prohlašuje, že typ rádiového zařízení je v souladu se směrnicí 2014/53/EU. Úplné znění EU prohlášení o shodě je k dispozici na této internetové adrese: https://www.denso.com/global/en/contact-us/doc/	16
DENSO CORPORATION potvrjuje, da je tip radijske opreme skladen z Direktivo 2014/53/EU. Celotno besedilo izjave EU o skladnosti je na voljo na naslednjem spletnem naslovu: https://www.denso.com/global/en/contact-us/doc/	17
Aš, DENSO CORPORATION, patvirtinu, kad radijo įrenginių tipas atitinka Direktyvą 2014/53/ES. Visas ES atitikties deklaracijos tekstas prieinamas šiuo interneto adresu: https://www.denso.com/global/en/contact-us/doc/	18
Ar šo DENSO CORPORATION deklarē, ka radioiekārta atbilst Direktīvai 2014/53/ES. Pilns ES atbilstības deklarācijas teksts ir pieejams šādā interneta vietnē: https://www.denso.com/global/en/contact-us/doc/	19

<p>DENSO CORPORATION niniejszym oświadcza, że typ urządzenia radiowego jest zgodny z dyrektywą 2014/53/UE. Pełny tekst deklaracji zgodności UE jest dostępny pod następującym adresem internetowym: https://www.denso.com/global/en/contact-us/doc/</p>	20
<p>Hér með lýsir DENSO CORPORATION yfir því að er í samræmi við grunnkröfur og aðrar kröfur, sem gerðar eru í tilskipun 2014/53/EU. Samræmisýfirlýsing er einnig aðgengileg á eftirfarandi vefslóð: https://www.denso.com/global/en/contact-us/doc/</p>	21
<p>DENSO CORPORATION erklærer at er i overensstemmelse med direktiv 2014/53/EU. Samsvarserklæringen i fulltekst er tilgjengelig på følgende internettadresse: https://www.denso.com/global/en/contact-us/doc/</p>	22
<p>С настоящото DENSO CORPORATION декларира, че този тип радиосъоръжение е в съответствие с Директива 2014/53/ЕС. Цялостният текст на ЕС декларацията за съответствие може да се намери на следния интернет адрес: https://www.denso.com/global/en/contact-us/doc/</p>	23
<p>Prin prezenta, DENSO CORPORATION declară că tipul de echipamente radio este în conformitate cu Directiva 2014/53/UE. Textul integral al declarației UE de conformitate este disponibil la următoarea adresă internet: https://www.denso.com/global/en/contact-us/doc/</p>	24

DENSO CORPORATION ovime izjavljuje da je radijska oprema tipa u skladu s Direktivom 2014/53/EU.

Cjeloviti tekst EU izjave o sukladnosti dostupan je na sljedećoj internetskoj adresi:

<https://www.denso.com/global/en/contact-us/doc/>

25

Овиме, DENSO CORPORATION изјављује да је радио опрема тип усаглашена са Директивом 2014/53/EU.

Цео текст ЕУ декларације о усаглашености доступан је на следећој интернет адреси:

<https://www.denso.com/global/en/contact-us/doc/>

26

Amb aquest document, DENSO CORPORATION declara que el tipus d'equipament radioelèctric es conforme a la Directiva 2014/53/UE.

El text complet de la declaració UE de conformitat està disponible en la següent adreça d'Internet:

<https://www.denso.com/global/en/contact-us/doc/>

27

İşbu belge; DENSO CORPORATION telsiz ekipmanı tipinin 2014/53/AB sayılı Direktif'e uygun olduğunu beyan eder.

AB uygunluk beyanının tam metni aşağıdaki internet adresinde mevcuttur:

<https://www.denso.com/global/en/contact-us/doc/>

28

Nepermjet kesaj, DENSO CORPORATION, deklaruj qe ky

DNMWR009 eshte ne pajtim me kerkesat thelbesore

dhe dispozitat e tjera perkatese te Direktives 1999/5/EC.

29



The latest "DECLARATION of CONFORMITY" (DoC) is available at the following address:

<https://www.denso.com/global/en/contact-us/doc/>

טויזטה מוטור אירופה נולסא, שדרות דו בורגט 60-1140 בריסל,

בלגיה www.toyota-europe.com

מוצר : מכ"מ התראה
סימן רשום : DENSO
ארץ ייצור : ראה מוצר
דגם : DNMWR009
שנת ייצור : ראה מוצר

For Vehicles sold in Ukraine
MODEL: DNMWR009



■ **If a warning message is displayed on the multi-information display**

A system may be temporarily unavailable or there may be a malfunction in the system.

- In the following situations, perform the actions specified in the table. When the normal operating conditions are detected, the message will disappear and the system will become operational.

If the message does not disappear, contact any authorized Lexus retailer or Lexus authorized repairer, or any reliable repairer.

Situation	Actions
When the area around a sensor is covered with dirt, moisture (fogged up, covered with condensation, ice, etc.), or other foreign matter	To clean the part of the windshield in front of the front camera, use the windshield wipers or the windshield defogger of the air conditioning system (→P.357).
When the temperature around the front camera is outside of the operational range, such as when the vehicle is in the sun or in an extremely cold environment	If the front camera is hot, such as after the vehicle had been parked in the sun, use the air conditioning system to decrease the temperature around the front camera. If a sunshade was used when the vehicle was parked, depending on its type, the sunlight reflected from the surface of the sunshade may cause the temperature of the front camera to become excessively high.
	If the front camera is cold, such after the vehicle is parked in an extremely cold environment, use the air conditioning system to increase the temperature around the front camera.
The area in front of the front camera is obstructed, such as when the hood is open or a sticker is attached to the part of the windshield in front of the front camera.	Close the hood, remove the sticker, etc. to clear the obstruction.

- In the following situations, if the situation has changed (or the vehicle has been driven for some time) and the normal operating conditions are detected, the message will disappear and the system will become operational.

If the message does not disappear, contact any authorized Lexus retailer or Lexus authorized repairer, or any reliable repairer.

When the temperature around the radar sensor is outside of the operational range, such as when the vehicle is in the sun or in an extremely cold environment

When the front camera cannot detect objects in front of the vehicle, such as when driving in the dark, snow, or fog, or when bright lights are shining into the front camera

PCS (Pre-Collision System)*

*: If equipped

The pre-collision system uses a radar sensor and front camera to detect objects (→P.260) in front of the vehicle. When the system determines that the possibility of a frontal collision with an object is high, a warning operates to urge the driver to take evasive action and the potential brake pressure is increased to help the driver avoid the collision. If the system determines that the possibility of a frontal collision with an object is extremely high, the brakes are automatically applied to help avoid the collision or help reduce the impact of the collision.

The pre-collision system can be disabled/enabled and the warning timing can be changed. (→P.262)

Detectable objects

Regions	Detectable objects	Countries/areas
A	<ul style="list-style-type: none"> • Vehicles • Bicyclists • Pedestrians 	Iceland, Ireland, United Kingdom, Italy, Ukraine, Estonia, Austria, Netherlands, Kazakhstan, Cyprus, Greece, Switzerland, Sweden, Spain, Slovakia, Slovenia, Czech Republic, Denmark, Germany, Norway, Hungary, Finland, France, Bulgaria, Belgium, Poland, Portugal, Malta, Monaco, Latvia, Lithuania, Romania, Russia, Israel, Turkey, Canary Islands
B	Vehicles	Azerbaijan, Armenia, Georgia

The countries and areas for each region listed in the table are current as of October 2018. However, depending on when the vehicle was sold, the countries and areas of each region may be different. Contact any authorized Lexus retailer or Lexus authorized repairer, or any reliable repairer for details.

System functions

■ Pre-collision warning

When the system determines that the possibility of a frontal collision is high, a buzzer will sound and a warning mes-

sage will be displayed on the multi-information display to urge the driver to take evasive action.

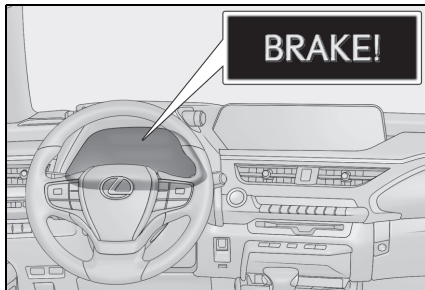

■ Pre-collision brake assist

When the system determines that the possibility of a frontal collision is high, the system applies greater braking force in relation to how strongly the brake pedal is depressed.

■ Pre-collision braking

If the system determines that the possibility of a frontal collision is extremely high, the brakes are automatically applied to help avoid the collision or reduce the impact of the collision.

■ Suspension control (if equipped)

When the system determines that the possibility of a frontal collision is high, the Adaptive Variable Suspension System (→P.340) will control the damping force of the shock absorbers to help maintain an appropriate vehicle posture.

⚠ WARNING

■ Limitations of the pre-collision system

- The driver is solely responsible for safe driving. Always drive safely, taking care to observe your surroundings. Do not use the pre-collision system instead of normal braking operations under any circumstances. This system will not prevent collisions or lessen collision damage or injury in every situation. Do not overly rely on this system. Failure to do so may lead to an accident, resulting in death or serious injury.

- Although this system is designed to help avoid a collision or help reduce the impact of the collision, its effectiveness may change according to various conditions, therefore the system may not always be able to achieve the same level of performance. Read the following conditions carefully. Do not overly rely on this system and always drive carefully.

- Conditions under which the system may operate even if there is no possibility of a collision: →P.264

- Conditions under which the system may not operate properly: →P.266

- Do not attempt to test the operation of the pre-collision system yourself. Depending on the objects used for testing (dummies, cardboard objects imitating detectable objects, etc.), the system may not operate properly, possibly leading to an accident.

■ Pre-collision braking

- When the pre-collision braking function is operating, a large amount of braking force will be applied.

- If the vehicle is stopped by the operation of the pre-collision braking function, the pre-collision braking function operation will be canceled after approximately 2 seconds. Depress the brake pedal as necessary.

**WARNING**

- The pre-collision braking function may not operate if certain operations are performed by the driver. If the accelerator pedal is being depressed strongly or the steering wheel is being turned, the system may determine that the driver is taking evasive action and possibly prevent the pre-collision braking function from operating.
- In some situations, while the pre-collision braking function is operating, operation of the function may be canceled if the accelerator pedal is depressed strongly or the steering wheel is turned and the system determines that the driver is taking evasive action.
- If the brake pedal is being depressed, the system may determine that the driver is taking evasive action and possibly delay the operation timing of the pre-collision braking function.

■ When to disable the pre-collision system

In the following situations, disable the system, as it may not operate properly, possibly leading to an accident resulting in death or serious injury:

- When the vehicle is being towed
- When your vehicle is towing another vehicle
- When transporting the vehicle via truck, boat, train or similar means of transportation
- When the vehicle is raised on a lift with the engine running and the tires are allowed to rotate freely
- When inspecting the vehicle using a drum tester such as a chassis dynamometer or speedometer tester, or when using an on vehicle wheel balancer

- When a strong impact is applied to the front bumper or front grille, due to an accident or other reasons
- If the vehicle cannot be driven in a stable manner, such as when the vehicle has been in an accident or is malfunctioning
- When the vehicle is driven in a sporty manner or off-road
- When the tires are not properly inflated
- When the tires are very worn
- When tires of a size other than specified are installed
- When tire chains are installed
- When a compact spare tire or an emergency tire puncture repair kit is used
- If equipment (snow plow, etc.) that may obstruct the radar sensor or front camera is temporarily installed to the vehicle

Changing settings of the pre-collision system**■ Enabling/disabling the pre-collision system**

The pre-collision system can be enabled/disabled on  (→P.115) of the multi-information display.

The system is automatically enabled each time the engine switch is turned to ON.

If the system is disabled, the PCS warning light will turn on and a message will be displayed on the multi-information display.

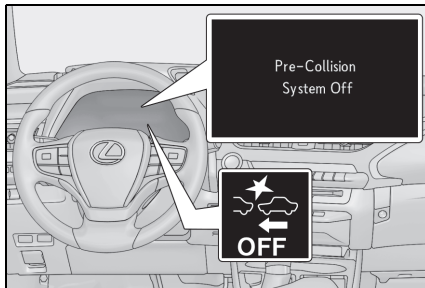

■ Changing the pre-collision warning timing

The pre-collision warning timing can be changed on  (→P.115) of the multi-information display.

The warning timing setting is retained when the engine switch is turned off. However, if the pre-collision system is disabled and re-enabled, the operation timing will

return to the default setting (middle).

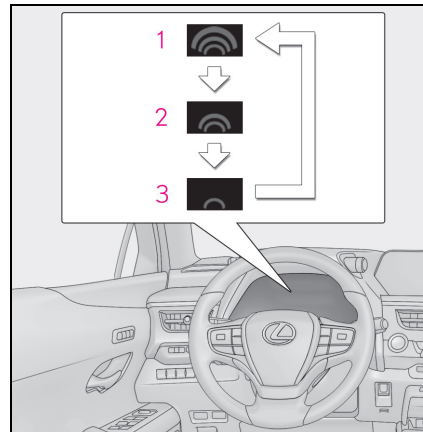

1 Early

2 Middle

This is the default setting.

3 Late

■ Operational conditions

The pre-collision system is enabled and the system determines that the possibility of a frontal collision with a detected object is high.

Each function is operational at the following speed

● Pre-collision warning

Detectable objects	Vehicle speed	Relative speed between your vehicle and object
Vehicles	Approx. 10 to 180 km/h (7 to 110 mph)	Approx. 10 to 180 km/h (7 to 110 mph)
Bicyclists and pedestrians *	Approx. 10 to 80 km/h (7 to 50 mph)	Approx. 10 to 80 km/h (7 to 50 mph)

● Pre-collision brake assist

Detectable objects	Vehicle speed	Relative speed between your vehicle and object
Vehicles	Approx. 30 to 180 km/h (20 to 110 mph)	Approx. 30 to 180 km/h (20 to 110 mph)
Bicyclists and pedestrians *	Approx. 30 to 80 km/h (20 to 50 mph)	Approx. 30 to 80 km/h (20 to 50 mph)

● Pre-collision braking

Detectable objects	Vehicle speed	Relative speed between your vehicle and object
Vehicles	Approx. 10 to 180 km/h (7 to 110 mph)	Approx. 10 to 180 km/h (7 to 110 mph)
Bicyclists and pedestrians *	Approx. 10 to 80 km/h (7 to 50 mph)	Approx. 10 to 80 km/h (7 to 50 mph)

*: Applicable to vehicles designed for regions that detection of pedestrians and/or bicyclists is possible (→P.260)

The system may not operate in the following situations:

- If a battery terminal has been disconnected and reconnected and then the vehicle has not been driven for a certain amount of time
- If the shift lever is in R
- When the VSC OFF indicator is illuminated (only the pre-collision warning function will be operational)

■ Object detection function

The system detects objects based on their size, profile, motion, etc. However, an object may not be detected depending on the surrounding brightness and the motion, posture, and angle of the detected object, preventing the system from operating properly. (→P.266) The illustration shows an image of detectable objects.

▶ Region A

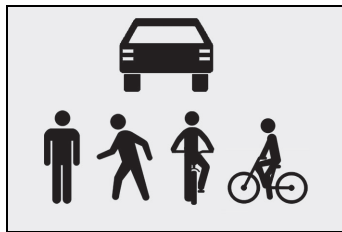

▶ Region B

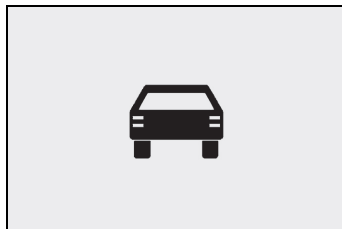

■ Cancellation of the pre-collision braking

If either of the following occur while the pre-collision braking function is operating, it will be canceled:

- The accelerator pedal is depressed strongly.
- The steering wheel is turned sharply or abruptly.

■ Conditions under which the system may operate even if there is no possibility of a collision

- In some situations such as the following, the system may determine that there is a possibility of a frontal collision and operate.
 - When passing a detectable object, etc.
 - When changing lanes while overtaking a detectable object, etc.
 - When approaching a detectable object in an adjacent lane or on the roadside, such as when changing the course of travel or driving on a winding road

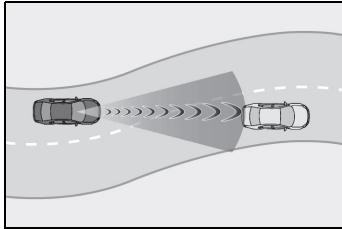

- When rapidly closing on a detectable object, etc.
- When approaching objects on the roadside, such as detectable objects, guardrails, utility poles, trees, or walls
- When there is a detectable object or other object by the roadside at the entrance of a curve

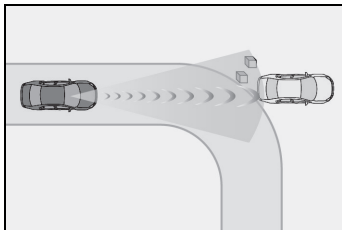

- When there are patterns or paint in front of your vehicle that may be mistaken for a detectable object
- When the front of your vehicle is hit by water, snow, dust, etc.
- When overtaking a detectable object that is changing lanes or making a right/left turn

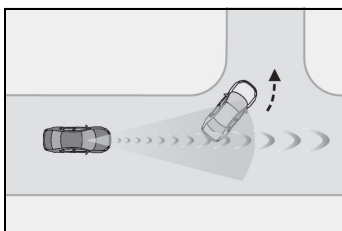

- When passing a detectable object in an oncoming lane that is stopped to make a right/left turn

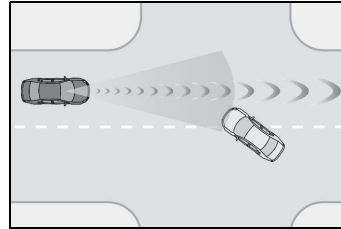

- When a detectable object approaches very close and then stops before entering the path of your vehicle
- If the front of your vehicle is raised or lowered, such as when on an uneven or undulating road surface
- When driving on a road surrounded by a structure, such as in a tunnel or on an iron bridge
- When there is a metal object (manhole cover, steel plate, etc.), steps, or a protrusion in front of your vehicle
- When passing under an object (road sign, billboard, etc.)

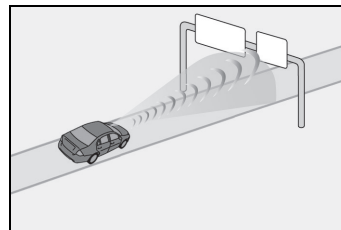

- When approaching an electric toll gate barrier, parking area barrier, or other barrier that opens and closes
- When using an automatic car wash
- When driving through or under objects that may contact your vehicle, such as thick grass, tree branches, or a banner

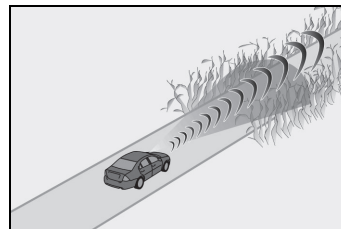

- When driving through steam or smoke
- When driving near an object that reflects radio waves, such as a large truck or

- guardrail
- When driving near a TV tower, broadcasting station, electric power plant, or other location where strong radio waves or electrical noise may be present

■ **Situations in which the system may not operate properly**

- In some situations such as the following, an object may not be detected by the radar sensor and front camera, preventing the system from operating properly:
 - When a detectable object is approaching your vehicle
 - When your vehicle or a detectable object is wobbling
 - If a detectable object makes an abrupt maneuver (such as sudden swerving, acceleration or deceleration)
 - When your vehicle approaches a detectable object rapidly
 - When a detectable object is not directly in front of your vehicle

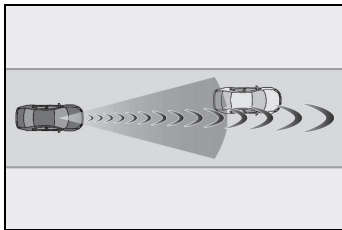

- When a detectable object is near a wall, fence, guardrail, manhole cover, vehicle, steel plate on the road, etc.
- When a detectable object is under a structure
- When part of a detectable object is hidden by an object, such as large baggage, an umbrella, or guardrail
- When multiple detectable objects are close together
- If the sun or other light is shining directly on a detectable object
- When a detectable object is a shade of white and looks extremely bright
- When a detectable object appears to be nearly the same color or brightness as its surroundings
- If a detectable object cuts or suddenly emerges in front of your vehicle
- When the front of your vehicle is hit by

- water, snow, dust, etc.
- When a very bright light ahead, such as the sun or the headlights of oncoming traffic, shines directly into the front camera
- When approaching the side or front of a vehicle ahead
- If a vehicle ahead is a bicycle^{*1} or motorcycle
- If a vehicle ahead is narrow, such as a personal mobility vehicle
- If a preceding vehicle has a small rear end, such as an unloaded truck
- If a preceding vehicle has a low rear end, such as a low bed trailer

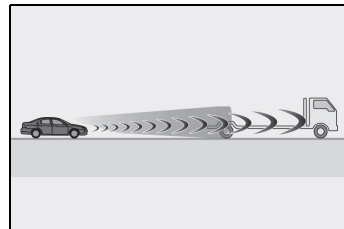

- If a vehicle ahead has extremely high ground clearance

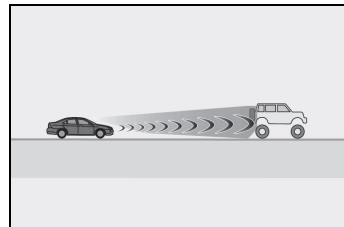

- If a vehicle ahead is carrying a load which protrudes past its rear bumper
- If a vehicle ahead is irregularly shaped, such as a tractor or side car
- If a vehicle ahead is a child sized bicycle, a bicycle that is carrying a large load, a bicycle ridden by more than one person, or a uniquely shaped bicycle (bicycle with a child seat, tandem bicycle, etc.)^{*2}
- If a pedestrian/or the riding height of a bicyclist ahead is shorter than approximately 1 m (3.2 ft.) or taller than approximately 2 m (6.5 ft.)^{*2}
- If a pedestrian/bicyclist is wearing oversized clothing (a rain coat, long skirt,

- etc.), making their silhouette obscure^{*2}
- If a pedestrian is bending forward or squatting or bicyclist is bending forward^{*2}
- If a pedestrian/bicyclist is moving fast^{*2}
- If a pedestrian is pushing a stroller, wheelchair, bicycle or other vehicle^{*2}
- When driving in inclement weather such as heavy rain, fog, snow or a sandstorm
- When driving through steam or smoke
- When the surrounding area is dim, such as at dawn or dusk, or while at night or in a tunnel, making a detectable object appear to be nearly the same color as its surroundings
- When driving in a place where the surrounding brightness changes suddenly, such as at the entrance or exit of a tunnel
- After the engine has started the vehicle has not been driven for a certain amount of time
- While making a left/right turn and for a few seconds after making a left/right turn
- While driving on a curve and for a few seconds after driving on a curve
- If your vehicle is skidding
- If the front of the vehicle is raised or lowered

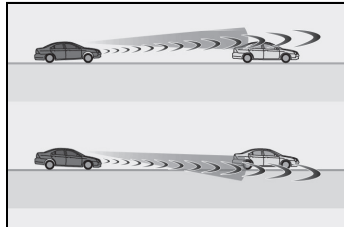

- If the wheels are misaligned
- If a wiper blade is blocking the front camera
- The vehicle is being driven at extremely high speeds
- When driving on a hill
- If the radar sensor or front camera is misaligned
- In some situations such as the following, sufficient braking force may not be obtained, preventing the system from performing properly:
 - If the braking functions cannot operate to

their full extent, such as when the brake parts are extremely cold, extremely hot, or wet

- If the vehicle is not properly maintained (brakes or tires are excessively worn, improper tire inflation pressure, etc.)
- When the vehicle is being driven on a gravel road or other slippery surface

^{*1}: Applicable to vehicles designed for countries/areas that detection of bicyclists is not possible (→P.260)

^{*2}: Applicable to vehicles designed for countries/areas that detection of pedestrians and/or bicyclists is possible (→P.260)

■ If VSC is disabled

- If VSC is disabled (→P.341), the pre-collision brake assist and pre-collision braking functions are also disabled.
- The PCS warning light will turn on and “VSC Turned Off Pre-Collision Brake System Unavailable” will be displayed on the multi-information display.

LTA (Lane Tracing Assist)*

*: If equipped

When driving on highways and freeways with white (yellow) lane lines, this function alerts the driver when the vehicle might depart from its lane or course* and provides assistance by operating the steering wheel to keep the vehicle in its lane or course*. Furthermore, the system provides steering assistance when dynamic radar cruise control with full-speed range is operating to keep the vehicle in its lane.

The LTA system recognizes white (yellow) lane lines or a course* using the front camera. Additionally, it detects preceding vehicles using the front camera and radar.

*: Boundary between asphalt and the side of the road, such as grass, soil, or a curb

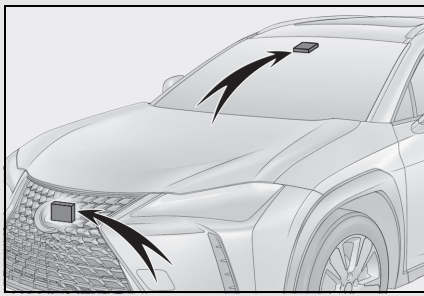

⚠ WARNING

■ Before using LTA system

- Do not rely solely upon the LTA system. The LTA system does not automatically drive the vehicle or reduce the amount of attention that must be paid to the area in front of the vehicle. The driver must always assume full responsibility for driving safely by paying careful attention to the surrounding conditions and operating the steering wheel to correct the path of the vehicle. Also, the driver must take adequate breaks when fatigued, such as from driving for a long period of time.
- Failure to perform appropriate driving operations and pay careful attention may lead to an accident, resulting in death or serious injury.

- When not using the LTA system, use the LTA switch to turn the system off.

■ Situations unsuitable for LTA system

In the following situations, use the LTA switch to turn the system off. Failure to do so may lead to an accident, resulting in death or serious injury.

- Vehicle is driven on a road surface which is slippery due to rainy weather, fallen snow, freezing, etc.
- Vehicle is driven on a snow-covered road.
- White (yellow) lines are difficult to see due to rain, snow, fog, dust, etc.
- Vehicle is driven in a temporary lane or restricted lane due to construction work.
- Vehicle is driven in a construction zone.
- A spare tire, tire chains, etc. are equipped.

⚠ WARNING

- When the tires have been excessively worn, or when the tire inflation pressure is low.
- When tires of a size other than specified are installed.
- Vehicle is driven in traffic lanes other than that highways and freeways.
- When your vehicle is towing a trailer (vehicles with towing package) or during emergency towing

■ Preventing LTA system malfunctions and operations performed by mistake

- Do not modify the headlights or place stickers, etc. on the surface of the lights.
- Do not modify the suspension etc. If the suspension etc. needs to be replaced, contact any authorized Lexus retailer or Lexus authorized repairer, or any reliable repairer.
- Do not install or place anything on the hood or grille. Also, do not install a grille guard (bull bars, kangaroo bar, etc.).
- If your windshield needs repairs, contact any authorized Lexus retailer or Lexus authorized repairer, or any reliable repairer.

■ Conditions in which functions may not operate properly

In the following situations, the functions may not operate properly and the vehicle may depart from its lane. Drive safely by always paying careful attention to your surroundings and operate the steering wheel to correct the path of the vehicle without relying solely on the functions.

- When the follow-up cruising display is displayed (→P.273) and the preceding vehicle changes lanes. (Your vehicle may follow the preceding vehicle and also change lanes.)

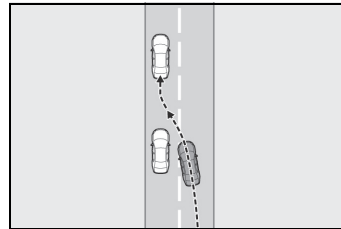

- When the follow-up cruising display is displayed (→P.273) and the preceding vehicle is swaying. (Your vehicle may sway accordingly and depart from the lane.)
- When the follow-up cruising display is displayed (→P.273) and the preceding vehicle departs from its lane. (Your vehicle may follow the preceding vehicle and depart from the lane.)
- When the follow-up cruising display is displayed (→P.273) and the preceding vehicle is being driven extremely close to the left/right lane line. (Your vehicle may follow the preceding vehicle and depart from the lane.)
- Vehicle is being driven around a sharp curve.

! WARNING

- Objects or patterns that could be mistaken for white (yellow) lines are present on the side of the road (guardrails, curbs, reflective poles, etc.).

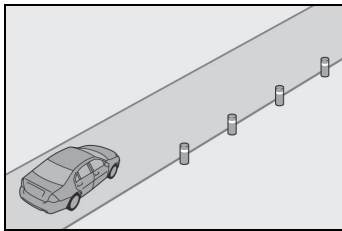

- Vehicle is driven where the road diverges, merges, etc.

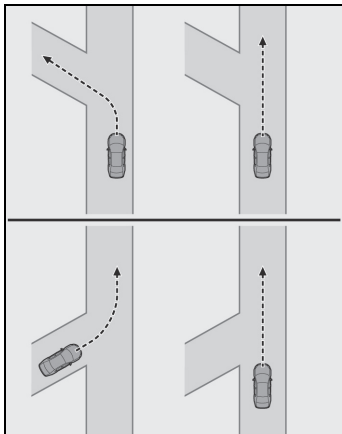

- Repair marks of asphalt, white (yellow) lines, etc. are present due to road repair.

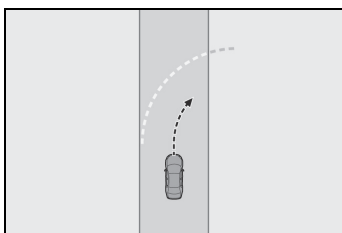

- There are shadows on the road that run parallel with, or cover, the white (yellow) lines.

- The vehicle is driven in an area without white (yellow) lines, such as in front of a tollgate or checkpoint, or at an intersection, etc.
- The white (yellow) lines are cracked, "Raised pavement marker" or stones are present.
- The white (yellow) lines cannot be seen or are difficult to see due to sand, etc.
- The vehicle is driven on a road surface that is wet due to rain, puddles, etc.
- The traffic lines are yellow (which may be more difficult to recognize than lines that are white).
- The white (yellow) lines cross over a curb, etc.
- The vehicle is driven on a bright surface, such as concrete.
- If the edge of the road is not clear or straight.
- The vehicle is driven on a surface that is bright due to reflected light, etc.
- The vehicle is driven in an area where the brightness changes suddenly, such as at the entrances and exits of tunnels, etc.
- Light from the headlights of an oncoming vehicle, the sun, etc. enters the camera.
- The vehicle is driven on a slope.
- The vehicle is driven on a road which tilts left or right, or a winding road.
- The vehicle is driven on an unpaved or rough road.
- The traffic lane is excessively narrow or wide.
- The vehicle is extremely tilted due to carrying heavy luggage or having improper tire pressure.

⚠ WARNING

- The distance to the preceding vehicle is extremely short.
- The vehicle is moving up and down a large amount due to road conditions during driving (poor roads or road seams).
- When driving in a tunnel or at night with the headlights off or when a headlight is dim due to its lens being dirty or it being misaligned.
- The vehicle is struck by a crosswind.
- The vehicle is affected by wind from a vehicle driven in a nearby lane.
- The vehicle has just changed lanes or crossed an intersection.
- Tires which differ by structure, manufacturer, brand or tread pattern are used.
- Snow tires, etc. are equipped.
- The vehicle is being driven at extremely high speeds.

Functions included in LTA system**■ Lane departure alert function**

When the system determines that the vehicle might depart from its lane or course^{*}, a warning is displayed on the multi-information display, and either a warning buzzer will sound or the steering wheel will vibrate to alert the driver.

When the warning buzzer sounds or the steering wheel vibrates, check the area around your vehicle and carefully operate the steering wheel to move the vehicle back to the center of the lane.

Vehicles with Blind Spot Monitor:

When the system determines that the vehicle might depart from its lane and that the possibility of a collision with an overtaking vehicle in the adjacent lane is high, the lane departure alert will operate even if the turn signals are operating.

* : Boundary between asphalt and the side of the road, such as grass, soil, or a curb

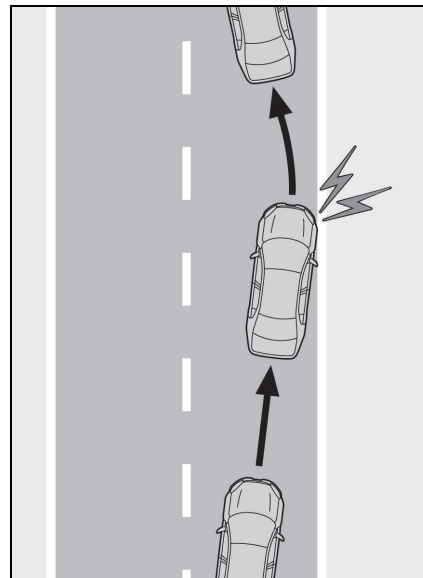
**■ Steering assist function**

When the system determines that the vehicle might depart from its lane or course^{*}, the system provides assistance as necessary by operating the steering wheel in small amounts for a short period of time to keep the vehicle in its lane.

If the system detects that the steering wheel has not been operated for a fixed amount of time or the steering wheel is not being firmly gripped, a

warning is displayed on the multi-information display and the function is temporarily canceled.

Vehicles with Blind Spot Monitor:
When the system determines that the vehicle might depart from its lane and that the possibility of a collision with an overtaking vehicle in the adjacent lane is high, the steering assist function will operate even if the turn signals are operating.

* : Boundary between asphalt and the side of the road, such as grass, soil, or a curb

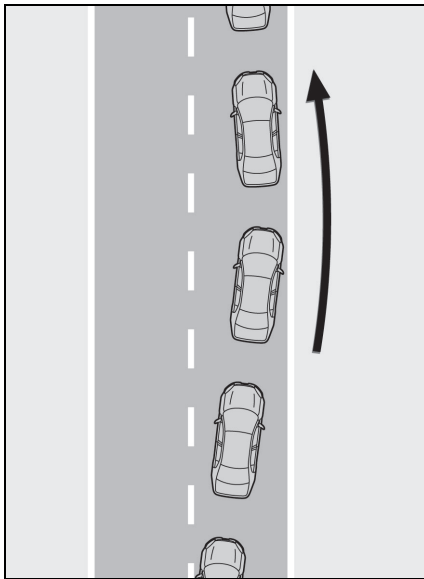

■ Vehicle sway warning function

When the vehicle is swaying within a lane, the warning buzzer will sound and a message will be displayed on the multi-information display to alert the driver.

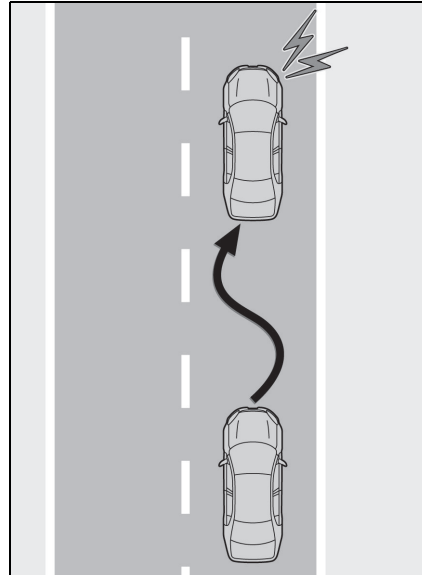

■ Lane centering function

This function is linked with dynamic radar cruise control with full-speed range and provides the required assistance by operating the steering wheel to keep the vehicle in its current lane.

When dynamic radar cruise control with full-speed range is not operating, the lane centering function does not operate.

In situations where the white (yellow) lane lines are difficult to see or are not visible, such as when in a traffic jam, this function will operate to help follow a preceding vehicle by monitoring the position of the preceding vehicle.

If the system detects that the steering wheel has not been operated for a fixed amount of time or the steering wheel is not being firmly gripped, a warning is displayed on the multi-infor-

mation display and the function is temporarily canceled.

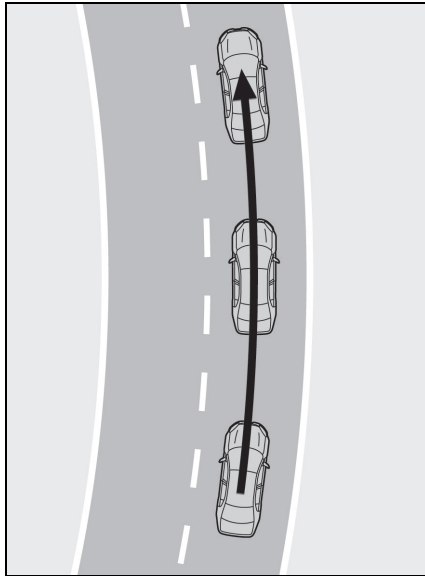

Turning LTA system on

Press the LTA switch to turn the LTA system on.

The LTA indicator illuminates and a message is displayed on the multi-information display.

Press the LTA switch again to turn the LTA system off.

When the LTA system is turned on or off, operation of the LTA system continues in the same condition the next time the engine is started.

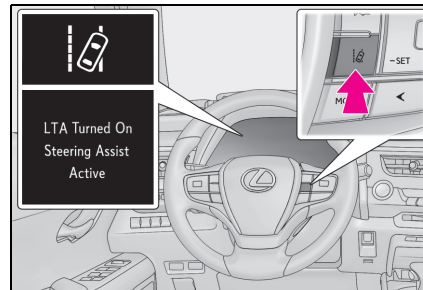

Indications on multi-information display

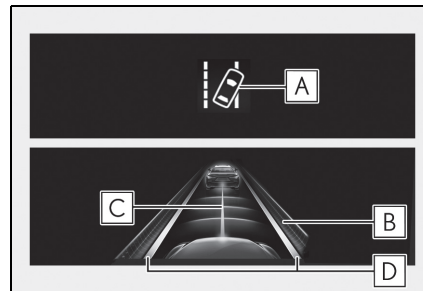

A LTA indicator

The illumination condition of the indicator informs the driver of the system operation status.

Illuminated in white:

LTA system is operating.

Illuminated in green:

Steering wheel assistance of the steering assist function or lane centering function is operating.

Flashing in orange:

Lane departure alert function is operating.

B Operation display of steering wheel operation support

Displayed when the multi-information display is switched to the driving support system information display.

Indicates that steering wheel assistance of

the steering assist function or lane centering function is operating.

Both outer sides of the lane are displayed:

Indicates that steering wheel assist of the lane centering function is operating.

One outer side of the lane is displayed:

Indicates that steering wheel assist of the steering assist function is operating.

Both outer sides of the lane are flashing:

Alerts the driver that their input is necessary to stay in the center of the lane (lane centering function).

C Follow-up cruising display

Displayed when the multi-information display is switched to the driving support system information display.

Indicates that steering assist of the lane centering function is operating by monitoring the position of a preceding vehicle.

When the follow-up cruising display is displayed, if the preceding vehicle moves, your vehicle may move in the same way.

Always pay careful attention to your surroundings and operate the steering wheel as necessary to correct the path of the vehicle and ensure safety.

D Lane departure alert function display

Displayed when the multi-information display is switched to the driving support system information display.

► Inside of displayed lines is white



Indicates that the system is recognizing white (yellow) lines or a course*. When the vehicle departs from its lane, the white line displayed on the side the vehicle departs from flashes orange.

► Inside of displayed lines is black



Indicates that the system is not able to recognize white (yellow) lines or a course* or is temporarily canceled.

*: Boundary between asphalt and the side of the road, such as grass, soil, or a curb

■ Operation conditions of each function

● Lane departure alert function

This function operates when all of the following conditions are met.

- LTA is turned on.
- Vehicle speed is approximately 50 km/h (32 mph) or more.*¹
- System recognizes white (yellow) lane lines or a course*². (When a white [yel-

low] line or a course^{*2} is recognized on only one side, the system will operate only for the recognized side.)

- Width of traffic lane is approximately 3 m (9.8 ft.) or more.
- Turn signal lever is not operated. (Vehicles with Blind Spot Monitor: Except when another vehicle is in the lane on the side where the turn signal was operated)
- Vehicle is not being driven around a sharp curve.
- No system malfunctions are detected. (→P.277)

*1: The function operates even if the vehicle speed is less than approximately 50 km/h (32 mph) when the lane centering function is operating.

*2: Boundary between asphalt and the side of the road, such as grass, soil, or a curb

● Steering assist function

This function operates when all of the following conditions are met in addition to the operation conditions for the lane departure alert function.

- Setting for "Steering Assist" in  of the multi-information display is set to "On". (→P.115)
- Vehicle is not accelerated or decelerated by a fixed amount or more.
- Steering wheel is not operated with a steering force level suitable for changing lanes.
- ABS, VSC, TRC and PCS are not operating.
- TRC or VSC is not turned off.
- Hands off steering wheel warning is not displayed. (→P.276)

● Vehicle sway warning function

This function operates when all of the following conditions are met.

- Setting for "Warning" in  of the multi-information display is set to "On". (→P.115)
- Vehicle speed is approximately 50 km/h (32 mph) or more.
- Width of traffic lane is approximately 3 m

(9.8 ft.) or more.

- No system malfunctions are detected. (→P.277)

● Lane centering function

This function operates when all of the following conditions are met.

- LTA is turned on.
- Setting for "Steering Assist" and "Lane Centre" in  of the multi-information display are set to "On". (→P.115)
- This function recognizes white (yellow) lane lines or the position of a preceding vehicle (except when the preceding vehicle is small, such as a motorcycle).
- The dynamic radar cruise control with full-speed range is operating in vehicle-to-vehicle distance control mode.
- Width of traffic lane is approximately 3 to 4 m (10 to 13 ft.).
- Turn signal lever is not operated.
- Vehicle is not being driven around a sharp curve.
- No system malfunctions are detected. (→P.277)
- Vehicle does not accelerate or decelerate by a fixed amount or more.
- Steering wheel is not operated with a steering force level suitable for changing lanes.
- ABS, VSC, TRC and PCS are not operating.
- TRC or VSC is not turned off.
- Hands off steering wheel warning is not displayed. (→P.276)
- The vehicle is being driven in the center of a lane.
- Steering assist function is not operating.

■ Temporary cancelation of functions

- When operation conditions are no longer met, a function may be temporarily canceled. However, when the operation conditions are met again, operation of the function is automatically restored. (→P.274)
- If the operation conditions (→P.274) are no longer met while the lane centering function is operating, the steering wheel may vibrate and the buzzer may sound to indicate that the function has been tem-

porarily canceled. However, if the “Steering wheel vibration” customization setting is set to “On”, the system will notify the driver by vibrating the steering wheel instead of sounding the buzzer.

■ Steering assist function/lane centering function

- Depending on the vehicle speed, lane departure situation, road conditions, etc., the driver may not feel the function is operating or the function may not operate at all.
- The steering control of the function is overridden by the driver’s steering wheel operation.
- Do not attempt to test the operation of the steering assist function.

■ Lane departure alert function

- The warning buzzer may be difficult to hear due to external noise, audio playback, etc. Also, it may be difficult to feel steering wheel vibrations due to the road conditions, etc.
- If the edge of the course* is not clear or straight, the lane departure alert function may not operate.
- Vehicles with Blind Spot Monitor: It may not be possible for the system to determine if there is a danger of a collision with a vehicle in an adjacent lane.
- Do not attempt to test the operation of the lane departure alert function.

*: Boundary between asphalt and the side of the road, such as grass, soil, or a curb

■ Hands off steering wheel warning

In the following situations, a warning message urging the driver to hold the steering wheel and the symbol shown in the illustration are displayed on the multi-information display to warn the driver. The warning stops when the system determines that the driver holds the steering wheel. Always keep your hands on the steering wheel when using this system, regardless of warnings.



- When the system determines that the driver is driving without holding the steering wheel while the system is operating

If the driver continues to keep their hands off of the steering wheel, the buzzer sounds, the driver is warned and the function is temporarily canceled. This warning also operates in the same way when the driver continuously operates the steering wheel only a small amount. The buzzer also sounds even if the alert type is set to “Steering wheel vibration”.

- When the system determines that the vehicle may not turn and instead depart from its lane while driving around a curve

Depending on the vehicle condition and road conditions, the warning may not operate. Also, if the system determines that the vehicle is driving around a curve, warnings will occur earlier than during straight-lane driving.

- When the system determines that the driver is driving without holding the steering wheel while the steering wheel assist of the steering assist function is operating.

If the driver continues to keep their hands off of the steering wheel and the steering wheel assist is operating, the buzzer sounds and the driver is warned. Each time the buzzer sounds, the continuing time of the buzzer becomes longer.

The buzzer also sounds even if the alert type is set to “Steering wheel vibration”.

■ Vehicle sway warning function

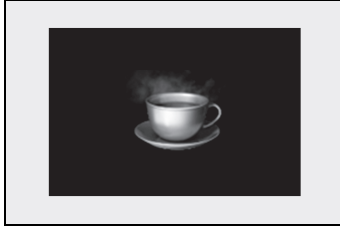

When the system determines that the vehicle is swaying while the vehicle sway warning function is operating, a buzzer sounds and a warning message urging the driver to rest and the symbol shown in the illustration are simultaneously displayed on the multi-information display.

Depending on the vehicle and road conditions, the warning may not operate.

■ Warning message

If the following warning message is displayed on the multi-information display and the LTA indicator illuminates in orange, follow the appropriate troubleshooting procedure. Also, if a different warning message is displayed, follow the instructions displayed on the screen.

● “LTA Unavailable”

The system is temporarily canceled due to a malfunction in a sensor other than the front camera. Turn the LTA system off, wait for a little while, and then turn the LTA system back on.

● “LTA Unavailable at Current Speed”

The function cannot be used as the vehicle speed exceeds the LTA operation range. Drive slower.

■ Customization

Function settings can be changed.
(Customizable features: →P.509)

RSA (Road Sign Assist)*

*: If equipped

The RSA system recognizes specific road signs using the front camera and navigation system (when data is available) to provide information to the driver via the display.



If the system judges that the vehicle is being driven over the speed limit, performing prohibited actions, etc. in relation to the recognized road signs, it alerts the driver using a warning display and warning buzzer or steering wheel vibration.

⚠ WARNING

■ Before using the RSA

Do not rely solely upon the RSA system. RSA is a system which supports the driver by providing information, but it is not a replacement for a driver's own vision and awareness. Drive safely by always paying careful attention to the traffic rules.

Indication on the multi-information display

When the front camera recognizes a sign and information of a sign is avail-

able from the navigation system, the sign will be displayed on the multi-information display.

- When the driving support system information display is selected, a maximum of 3 signs can be displayed. (→P.115)

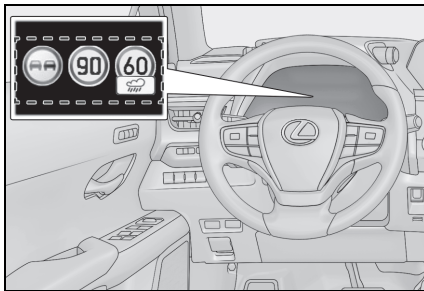

- When a tab other than the driving support system information display is selected, only a recognized speed limit sign, a no-entry sign (when notification is necessary), expressway sign, highway sign or Residential area sign will be displayed. (→P.115)

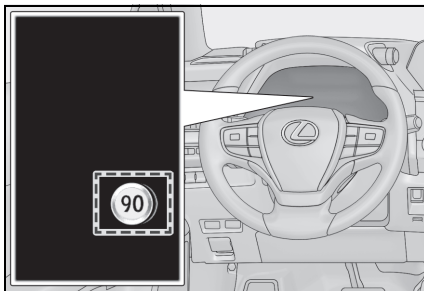

A no overtaking sign and a speed limit sign with supplemental mark are not displayed. However, if signs other than speed limit signs are recognized, they will be displayed in an overlapping stack under the current speed limit sign.

Supported types of road signs

The following types of road signs, including electronic signs and blinking signs, are recognized.

A non-official (not meeting the Vienna Convention) or a recently introduced traffic sign may not be recognized.

- Speed limit road signs

 : Speed limit begins/Maximum speed zone begins

 : Speed limit ends/Maximum speed zone ends

- Speed limit related information *

 : Expressway entrance

 : Expressway exit

 : Highway entrance

 : Highway exit

 : Urban area beginning

 : Urban area ending

 : Urban area beginning



: Urban area ending



: Residential area beginning



: Residential area ending

* : Displayed when a sign is recognized but speed limit information for the road is not available from the navigation system

- No-overtaking road signs



: No overtaking begins



: No overtaking ends

- Other road signs



: No-entry *



: All canceled



: Stop

* : For vehicles with navigation system

- Speed limit with supplemental mark^{*1}



: Wet



: Rain

: Ice^{*2}: Supplemental mark exists^{*3}: Exit ramp on right^{*3}: Exit ramp on left^{*3}

: Time

^{*1}: Displayed simultaneously with speed limit

^{*2}: Contents not recognized.

^{*3}: If the turn signal indicator is not operated when changing lanes, the mark does not display.











Warning indication

In the following situations, the RSA system will alert the driver.

- When the vehicle speed exceeds the speed warning threshold of the speed limit sign displayed, the sign display will be emphasized and a buzzer will sound.
For vehicles with navigation system: When the RSA system recognizes a no-entry sign and detects that the vehicle has entered a no-entry area based on the map information of the navigation system, the no-entry sign flashes and a buzzer will sound.
- If it is detected that your vehicle is overtaking when a no overtaking sign is displayed on the multi-information display, the displayed sign will flash and a buzzer will sound or a steering wheel will vibrate. Depending on the situation, traffic

environment (traffic direction, speed unit) may be detected incorrectly and a warning indication may not operate properly.

■ Setting procedure

- 1 Press  or  of the meter control switches and select .
- 2 Press  or  of the meter control switches and select "Vehicle Settings", then press "OK".
- 3 Press  or  of the meter control switches and select , then press "OK".
- 4 Press  or  of the meter control switches and select "RSA", then press "OK".

■ Automatic turn-off of RSA sign display

One or more signs automatically turn off in the following situations.

- A new sign is not recognized for a certain distance.
- The road changes due to a left or right turn, etc.

■ Conditions in which the function may not operate or detect correctly

In the following situations, RSA does not operate normally and may not recognize signs, display the incorrect sign, etc. However, this does not indicate a malfunction.

- The front camera is misaligned due to a strong impact being applied to the sensor, etc.
- Dirt, snow, stickers, etc. are on the windshield near the front camera.
- In inclement weather such as heavy rain, fog, snow or sand storms
- Light from an oncoming vehicle, the sun, etc. enters the front camera.
- The sign is dirty, faded, tilted or bent, and if an electronic sign, the contrast is poor.

- All or part of the sign is hidden by the leaves of a tree, a pole, etc.
- The sign is only visible to the front camera for a short amount of time.
- The driving scene (turning, lane change, etc.) is judged incorrectly.
- Even if it is a sign not appropriate for the currently traveled lane, such a sign exists directly after a freeway branches, or in an adjacent lane just before merging.
- Stickers are attached to the rear of the preceding vehicle.
- A sign resembling a system compatible sign is recognized.
- Side road speed signs may be detected and displayed (if positioned in sight of the front camera) while the vehicle is traveling on the main road.
- Roundabout exit road speed signs may be detected and displayed (if positioned in sight of the front camera) while traveling on a roundabout.
- The front of the vehicle is raised or lowered due to the carried load.
- The surrounding brightness is not sufficient or changes suddenly.
- When a sign intended for trucks, etc. is recognized.
- The vehicle is driven in a country with a different direction of traffic.
- The navigation system map data is old.*
- The navigation system is operating.*
- The speed information displayed on the meter and that displayed on the navigation system may be different due to the navigation system using map data.*

*: For vehicles with navigation system

■ Speed limit sign display

If the engine switch was last turned off while a speed limit sign was displayed on the multi-information display, the same sign displays again when the engine switch is turned to ON.

■ Customization

Some functions can be customized. (Customizable features: →P.509)

Dynamic radar cruise control with full-speed range*

*: If equipped

In vehicle-to-vehicle distance control mode, the vehicle automatically accelerates, decelerates and stops to match the speed changes of the preceding vehicle even if the accelerator pedal is not depressed. In constant speed control mode, the vehicle runs at a fixed speed.

Use the dynamic radar cruise control with full-speed range on free-ways and highways.

- Vehicle-to-vehicle distance control mode (→P.284)
- Constant speed control mode (→P.288)

System components

■ Meter display

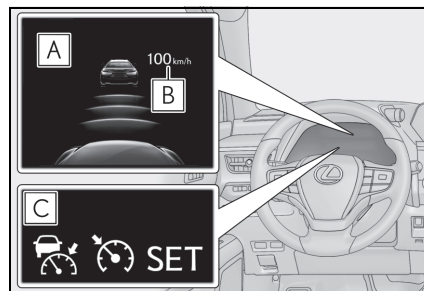

A Multi-information display

B Set speed

C Indicators

■ Operation switches

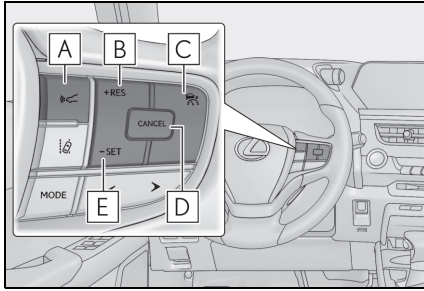

- A** Vehicle-to-vehicle distance switch
- B** "+RES" switch
- C** Cruise control main switch
- D** Cancel switch
- E** "-SET" switch

⚠ WARNING

■ Before using dynamic radar cruise control with full-speed range

- Driving safely is the sole responsibility of the driver. Do not rely solely on the system, and drive safely by always paying careful attention to your surroundings.
- The dynamic radar cruise control with full-speed range provides driving assistance to reduce the driver's burden. However, there are limitations to the assistance provided.

Read the following conditions carefully. Do not overly rely on this system and always drive carefully.

- When the sensor may not be correctly detecting the vehicle ahead: →P.290
- Conditions under which the vehicle-to-vehicle distance control mode may not function correctly: →P.291

- Set the speed appropriately depending on the speed limit, traffic flow, road conditions, weather conditions, etc. The driver is responsible for checking the set speed.
- Even when the system is functioning normally, the condition of the preceding vehicle as detected by the system may differ from the condition observed by the driver. Therefore, the driver must always remain alert, assess the danger of each situation and drive safely. Relying solely on this system or assuming the system ensures safety while driving can lead to an accident, resulting in death or serious injury.
- Switch the dynamic radar cruise control with full-speed range setting to off, using the cruise control main switch when not in use.

■ Cautions regarding the driving assist systems

Observe the following precautions, as there are limitations to the assistance provided by the system. Failure to do so may cause an accident resulting in death or serious injury.

- Assisting the driver to measure following distance
The dynamic radar cruise control with full-speed range is only intended to help the driver in determining the following distance between the driver's own vehicle and a designated vehicle traveling ahead. It is not a mechanism that allows careless or inattentive driving, and it is not a system that can assist the driver in low-visibility conditions. It is still necessary for driver to pay close attention to the vehicle's surroundings.

**WARNING**

- **Assisting the driver to judge proper following distance**
The dynamic radar cruise control with full-speed range determines whether the following distance between the driver's own vehicle and a designated vehicle traveling ahead is within a set range. It is not capable of making any other type of judgement. Therefore, it is absolutely necessary for the driver to remain vigilant and to determine whether or not there is a possibility of danger in any given situation.
- **Assisting the driver to operate the vehicle**
The dynamic radar cruise control with full-speed range does not include functions which will prevent or avoid collisions with vehicles ahead of your vehicle. Therefore, if there is ever any possibility of danger, the driver must take immediate and direct control of the vehicle and act appropriately in order to ensure the safety of all involved.

■ **Situations unsuitable for dynamic radar cruise control with full-speed range**

Do not use dynamic radar cruise control with full-speed range in any of the following situations.

Doing so may result in inappropriate speed control and could cause an accident resulting in death or serious injury.

- Roads where there are pedestrians, cyclists, etc.
- In heavy traffic
- On roads with sharp bends
- On winding roads
- On slippery roads, such as those covered with rain, ice or snow

- On steep downhills, or where there are sudden changes between sharp up and down gradients
Vehicle speed may exceed the set speed when driving down a steep hill.
- At entrances to freeways and highways
- When weather conditions are bad enough that they may prevent the sensors from detecting correctly (fog, snow, sandstorm, heavy rain, etc.)
- When there is rain, snow, etc. on the front surface of the radar or front camera
- In traffic conditions that require frequent repeated acceleration and deceleration
- When your vehicle is towing a trailer (vehicles with towing package) or during emergency towing
- When an approach warning buzzer is heard often

Driving in vehicle-to-vehicle distance control mode

This mode employs a radar to detect the presence of vehicles up to approximately 100 m (328 ft.) ahead, determines the current vehicle-to-vehicle following distance, and operates to maintain a suitable following distance from the vehicle ahead. The desired vehicle-to-vehicle distance can also be set by operating the vehicle-to-vehicle distance switch.

When driving on downhill slopes, the vehicle-to-vehicle distance may become shorter.

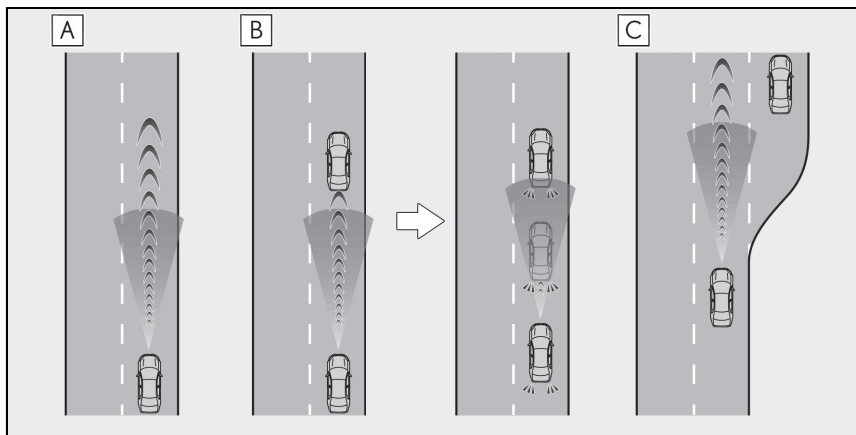

A Example of constant speed cruising

When there are no vehicles ahead

The vehicle travels at the speed set by the driver.

B Example of deceleration cruising and follow-up cruising

When a preceding vehicle driving slower than the set speed appears

When a vehicle is detected running ahead of you, the system automatically decelerates your vehicle. When a greater reduction in vehicle speed is necessary, the system applies the brakes (the stop lights will come on at this time). The system will respond to changes in the speed of the vehicle ahead in order to maintain the vehicle-to-vehicle distance set by the driver. Approach warning warns you when the system cannot decelerate sufficiently to prevent your vehicle from closing in on the vehicle ahead.

When the vehicle ahead of you stops, your vehicle will also stop (vehicle is stopped by system control). After the vehicle ahead starts off, pressing the "+RES" switch or depressing the accelerator pedal (start-off operation) will resume follow-up cruising. If the start-off operation is not performed, system control continues to keep your vehicle stopped.

When the turn signal lever is operated and your vehicle moves to a left lane while driving at 80 km/h (50 mph) or more, the vehicle will quickly accelerate to help to overtake a passing vehicle.

C Example of acceleration

When there are no longer any preceding vehicles driving slower than the set speed

The system accelerates until the set speed is reached. The system then returns to constant speed cruising.

Setting the vehicle speed (vehicle-to-vehicle distance control mode)

- 1 Press the cruise control main switch to activate the cruise control.

Dynamic radar cruise control indicator will come on and a message will be displayed on the multi-information display. Press the switch again to deactivate the cruise control.

If the cruise control main switch is pressed and held for 1.5 seconds or more, the system turns on in constant speed control mode. (→P.288)

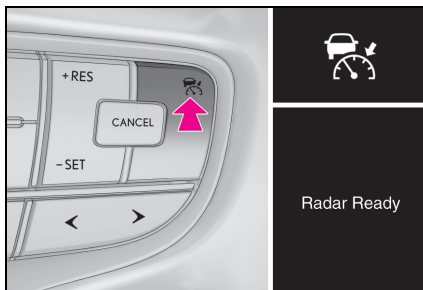

- 2 Accelerate or decelerate, with accelerator pedal operation, to the desired vehicle speed (at or above approximately 30 km/h [20 mph]) and press the "-SET" switch to set the speed.

Cruise control "SET" indicator will come on.

The vehicle speed at the moment the

switch is released becomes the set speed.

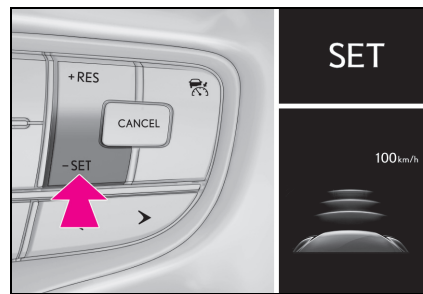

Adjusting the set speed

To change the set speed, press the "+RES" or "-SET" switch until the desired set speed is displayed.

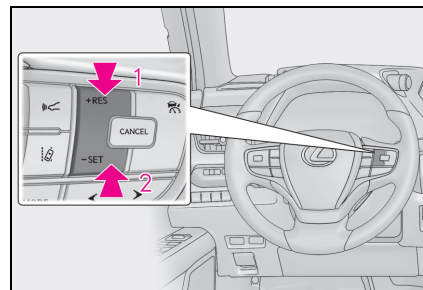

- 1 Increases the speed (Except when the vehicle has been stopped by system control in vehicle-to-vehicle distance control mode)
- 2 Decreases the speed
Fine adjustment: Press the switch.
Large adjustment: Press and hold the switch to change the speed, and release

when the desired speed is reached.

In the vehicle-to-vehicle distance control mode, the set speed will be increased or decreased as follows:

► For Europe

Fine adjustment: By 5 km/h (3.1 mph)^{*1} or 5 mph (8 km/h)^{*2} each time the switch is pressed

Large adjustment: Increases or decreases in 5 km/h (3.1 mph)^{*1} or 5 mph (8 km/h)^{*2} increments for as long as the switch is held

► Except for Europe

Fine adjustment: By 1 km/h (0.6 mph)^{*1} or 1 mph (1.6 km/h)^{*2} each time the switch is pressed

Large adjustment: Increases or decreases in 5 km/h (3.1 mph)^{*1} or 5 mph (8 km/h)^{*2} increments for as long as the switch is held

In the constant speed control mode (→P.288), the set speed will be increased or decreased as follows:

Fine adjustment: By 1 km/h (0.6 mph)^{*1} or 1 mph (1.6 km/h)^{*2} each time the switch is pressed

Large adjustment: The speed will continue to change while the switch is held.

^{*1}: When the set speed is shown in "km/h"

^{*2}: When the set speed is shown in "MPH"

Changing the vehicle-to-vehicle distance (vehicle-to-vehicle distance control mode)

Pressing the switch changes the vehicle-to-vehicle distance as follows:

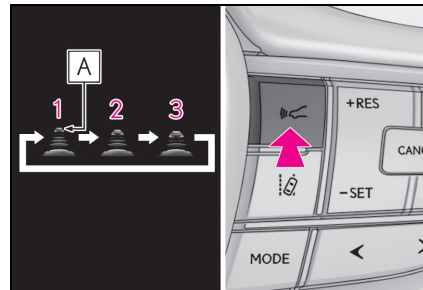

- 1 Long
- 2 Medium
- 3 Short

The vehicle-to-vehicle distance is set automatically to long mode when the engine switch is turned to ON.

If a vehicle is running ahead of you, the preceding vehicle mark **A** will also be displayed.

Vehicle-to-vehicle distance settings (vehicle-to-vehicle distance control mode)

Select a distance from the table below. Note that the distances shown correspond to a vehicle speed of 80 km/h (50 mph). Vehicle-to-vehicle distance increases/decreases in accordance with vehicle speed. When the vehicle is stopped by system control, the vehicle stops at a certain vehicle-to-vehicle distance depending on the situation.

Distance options	Vehicle-to-vehicle distance
Long	Approximately 50 m (160 ft.)
Medium	Approximately 40 m (130 ft.)
Short	Approximately 30 m (100 ft.)

Resuming follow-up cruising when the vehicle has been stopped by system control (vehicle-to-vehicle distance control mode)

After the vehicle ahead of you starts off, press the "+RES" switch.

Your vehicle will also resume follow-up cruising if the accelerator pedal is depressed after the vehicle ahead of you starts off.



Canceling and resuming the speed control

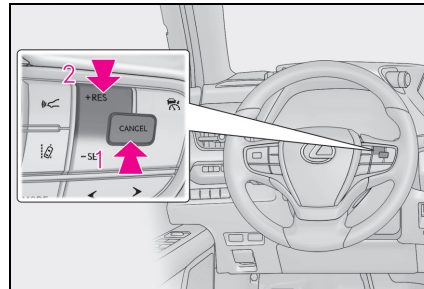

- 1 Pressing the cancel switch cancels the speed control.

The speed control is also canceled when the brake pedal is depressed. (When the vehicle has been stopped by system control, depressing the brake pedal does not cancel the setting.)

- 2 Pressing the "+RES" switch resumes the cruise control and returns vehicle speed to the set speed.

Approach warning (vehicle-to-vehicle distance control mode)

When your vehicle is too close to a vehicle ahead, and sufficient automatic deceleration via the cruise control is not possible, the display will flash and the buzzer will sound to alert the driver. An example of this would be if another driver cuts in front of you while you are following a vehicle. Depress the brake pedal to ensure an appropriate vehicle-to-vehicle distance.

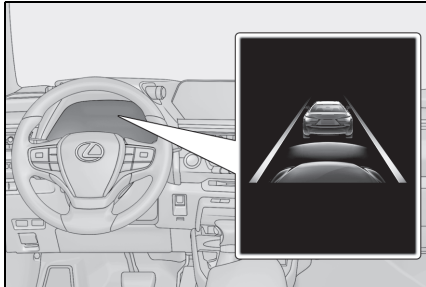

■ **Warnings may not occur when**

In the following instances, warnings may not occur even when the vehicle-to-vehicle distance is small.

- When the speed of the preceding vehicle matches or exceeds your vehicle speed
- When the preceding vehicle is traveling at an extremely slow speed
- Immediately after the cruise control speed was set
- When depressing the accelerator pedal

Selecting constant speed control mode

When constant speed control mode is selected, your vehicle will maintain a set speed without controlling the vehicle-to-vehicle distance. Select this mode only when vehicle-to-vehicle distance control mode does not function correctly due to a dirty radar, etc.

- 1 With the cruise control off, press and hold the cruise control main switch for 1.5 seconds or more.

Immediately after the switch is pressed, the dynamic radar cruise control indicator will

come on. Afterwards, it switches to the cruise control indicator.

Switching to constant speed control mode is only possible when operating the switch with the cruise control off.

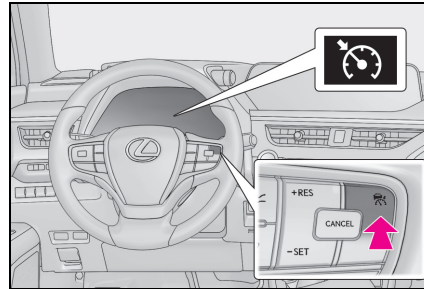

- 2 Accelerate or decelerate, with accelerator pedal operation, to the desired vehicle speed (at or above approximately 30 km/h [20 mph]) and press the "-SET" switch to set the speed.

Cruise control "SET" indicator will come on.

The vehicle speed at the moment the switch is released becomes the set speed.

Adjusting the speed setting: →P.285

Canceling and resuming the speed setting: →P.287

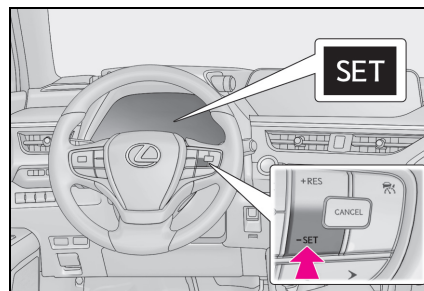

Dynamic Radar Cruise Control with Road Sign Assist

When this function is enabled and the system is operating in vehicle-to-vehicle-

cle distance control mode (→P.284), when a speed limit sign is detected, the recognized speed limit will be displayed with an up/down arrow. The set speed can be increased/reduced to the recognized speed limit by pressing and holding the “+RES”/“-SET” switch.

- When the current set speed is lower than the recognized speed limit

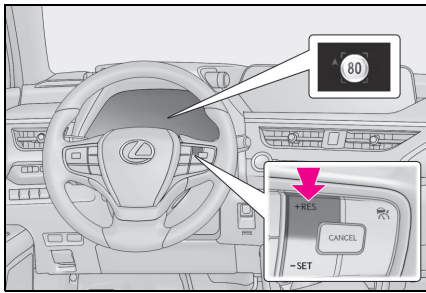

- Press and hold the “+RES” switch.
- When the current set speed is higher than the recognized speed limit

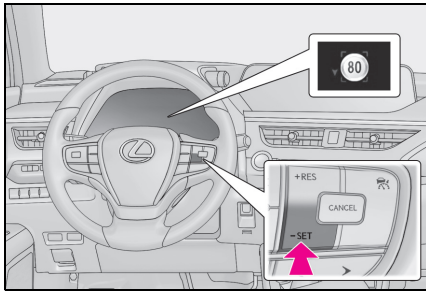

- Press and hold the “-SET” switch.

Enabling/Disabling the Dynamic Radar Cruise Control with Road Sign Assist

Dynamic Radar Cruise Control with Road Sign Assist can be enabled/dis-

abled in  on the multi-information display. (→P.115)

■ Dynamic radar cruise control with full-speed range can be set when

- The shift lever is in D.
- The desired set speed can be set when the vehicle speed is approximately 30 km/h (20 mph) or more. (However, when the vehicle speed is set while driving at below approximately 30 km/h [20 mph], the set speed will be set to approximately 30 km/h [20 mph].)

■ Accelerating after setting the vehicle speed

The vehicle can accelerate by operating the accelerator pedal. After accelerating, the set speed resumes. However, during vehicle-to-vehicle distance control mode, the vehicle speed may decrease below the set speed in order to maintain the distance to the preceding vehicle.

■ When the vehicle stops while follow-up cruising

- Pressing the “+RES” switch while the vehicle ahead stops will resume follow-up cruising if the vehicle ahead starts off within approximately 3 seconds after the switch is pressed.
- If the vehicle ahead starts off within 3 seconds after your vehicle stops, follow-up cruising will be resumed.

■ Automatic cancelation of vehicle-to-vehicle distance control mode

Vehicle-to-vehicle distance control mode is automatically canceled in the following situations.

- VSC is activated.
- TRC is activated for a period of time.
- When the VSC or TRC system is turned off.
- The sensor cannot detect correctly because it is covered in some way.
- Pre-collision braking is activated.
- The parking brake is operated.

- The vehicle is stopped by system control on a steep incline.
- The following are detected when the vehicle has been stopped by system control:
 - The driver is not wearing a seat belt.
 - The driver's door is opened.
 - The vehicle has been stopped for about 3 minutes

If vehicle-to-vehicle distance control mode is automatically canceled for any reasons other than the above, there may be a malfunction in the system. Contact any authorized Lexus retailer or Lexus authorized repairer, or any reliable repairer.

■ Automatic cancellation of constant speed control mode

Constant speed control mode is automatically canceled in the following situations:

- Actual vehicle speed is more than approximately 16 km/h (10 mph) below the set vehicle speed.
- Actual vehicle speed falls below approximately 30 km/h (20 mph).
- VSC is activated.
- TRC is activated for a period of time.
- When the VSC or TRC system is turned off.
- Pre-collision braking is activated.

If constant speed control mode is automatically canceled for any reasons other than the above, there may be a malfunction in the system. Contact any authorized Lexus retailer or Lexus authorized repairer, or any reliable repairer.

■ The Dynamic Radar Cruise Control with Road Sign Assist may not operate properly when

As the Dynamic Radar Cruise Control with Road Sign Assist may not operate properly in conditions in which RSA may not operate or detect correctly (→P.280), when using this function, make sure to check the speed limit sign displayed.

In the following situations, the set speed may not be changed to the recognized speed limit by pressing and holding the "+RES"/"-SET" switch.

- If speed limit information is not available
- When the recognized speed limit is the same as the set speed
- When the recognized speed limit is outside of the speed range that the dynamic radar cruise control system can operate

■ Brake operation

A brake operation sound may be heard and the brake pedal response may change, but these are not malfunctions.

■ Warning messages and buzzers for dynamic radar cruise control with full-speed range

Warning messages and buzzers are used to indicate a system malfunction or to inform the driver of the need for caution while driving. If a warning message is shown on the multi-information display, read the message and follow the instructions. (→P.258, 452)

■ When the sensor may not be correctly detecting the vehicle ahead

In the case of the following and depending on the conditions, operate the brake pedal when deceleration of the system is insufficient or operate the accelerator pedal when acceleration is required.

As the sensor may not be able to correctly detect these types of vehicles, the approach warning (→P.287) may not be activated.

- Vehicles that cut in suddenly
- Vehicles traveling at low speeds
- Vehicles that are not moving in the same lane
- Vehicles with small rear ends (trailers with no load on board, etc.)

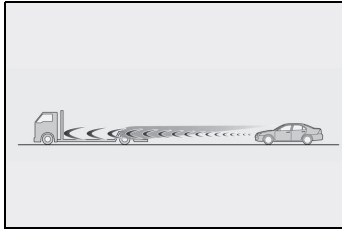

- Motorcycles traveling in the same lane
- When water or snow thrown up by the surrounding vehicles hinders the detecting of the sensor
- When your vehicle is pointing upwards (caused by a heavy load in the luggage compartment, etc.)

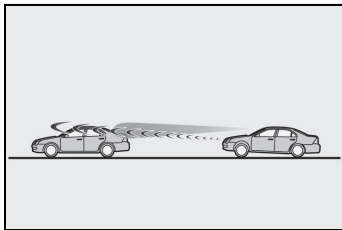

- Preceding vehicle has an extremely high ground clearance

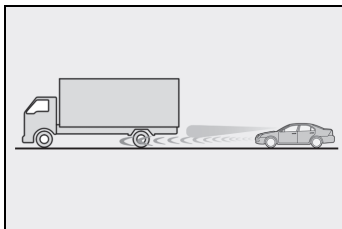

■ Conditions under which the vehicle-to-vehicle distance control mode may not function correctly

In the case of the following conditions, operate the brake pedal (or accelerator pedal, depending on the situation) as necessary.

As the sensor may not be able to correctly detect vehicles ahead, the system may not operate properly.

- When the road curves or when the lanes are narrow

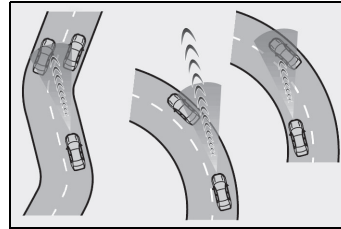

- When steering wheel operation or your position in the lane is unstable

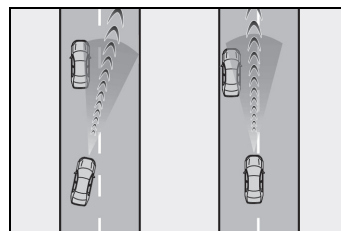

- When the vehicle ahead of you decelerates suddenly
- When driving on a road surrounded by a structure, such as in a tunnel or on a bridge
- While the vehicle speed is decreasing to the set speed after the vehicle accelerates by depressing the accelerator pedal

Cruise control*

*: If equipped

Use the cruise control to maintain a set speed without depressing the accelerator pedal.

Use the cruise control on freeways and highways.

System components

Meter display

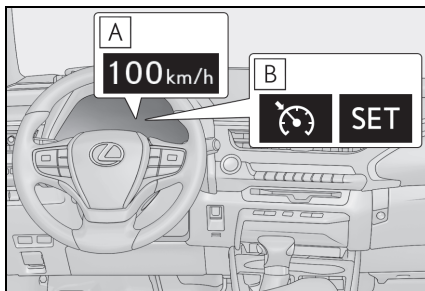

A Set speed

B Indicators

Operation switches

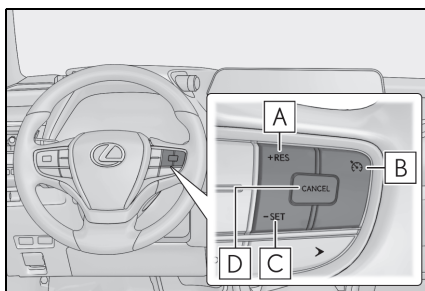

A "+RES" switch

B Cruise control main switch

C "-SET" switch

D Cancel switch

Setting the vehicle speed

- 1 Press the cruise control main switch to activate the cruise control.

Cruise control indicator will come on. Press the switch again to deactivate the cruise control.

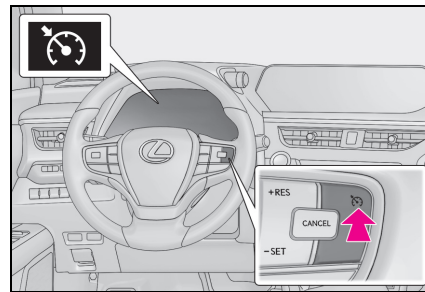

- 2 Accelerate or decelerate the vehicle to the desired speed, and press the "-SET" switch to set the speed.

Cruise control "SET" indicator will come on. The vehicle speed at the moment the switch is released becomes the set speed.

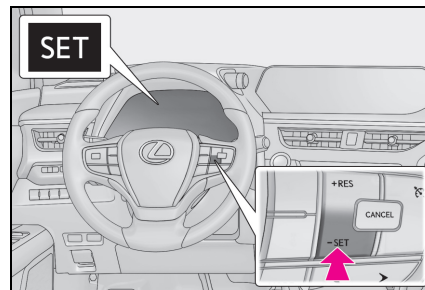

Adjusting the set speed

To change the set speed, press the "+RES" or "-SET" switch until the desired set speed is obtained.

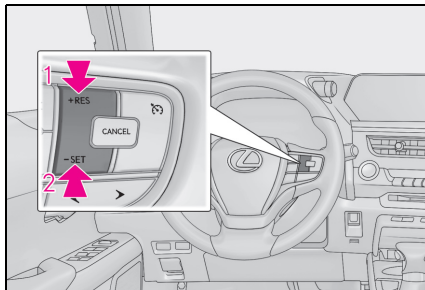

- 1 Increases the speed
- 2 Decreases the speed

Fine adjustment: Press the switch.

Large adjustment: Press and hold switch.

The set speed will be increased or decreased as follows:

Fine adjustment: By approximately 1 km/h (0.6 mph)^{*1} or 1 mph (1.6 km/h)^{*2} each time the switch is pressed.

Large adjustment: The set speed can be increased or decreased continually until the switch is released.

*1: When the set speed is shown in "km/h"

*2: When the set speed is shown in "MPH"

Canceling and resuming the constant speed control

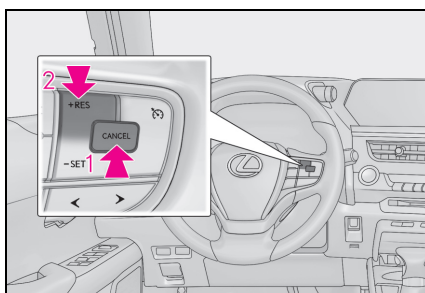

- 1 Pressing the cancel switch cancels the constant speed control.

The speed setting is also canceled when the brakes are applied.

- 2 Pressing the "+RES" switch resumes the constant speed control.

Resuming is available when the vehicle speed is more than approximately 30 km/h (20 mph).

■ Cruise control can be set when

- The shift lever is in D.
- Vehicle speed is above approximately 30 km/h (20 mph).

■ Accelerating after setting the vehicle speed

- The vehicle can be accelerated normally. After acceleration, the set speed resumes.
- Even without canceling the cruise control, the set speed can be increased by first accelerating the vehicle to the desired speed and then pressing the "-SET" switch to set the new speed.

■ Automatic cruise control cancelation

Cruise control will stop maintaining the vehicle speed in any of the following situations.

- Actual vehicle speed falls more than approximately 16 km/h (10 mph) below the preset vehicle speed.
- Actual vehicle speed is below approximately 30 km/h (20 mph).
- VSC is activated.
- TRC is activated for a period of time.
- When the VSC or TRC system is turned off.

■ If the warning message for the cruise control is shown on the multi-information display

Press the cruise control main switch once to deactivate the system, and then press the switch again to reactivate the system.

If the cruise control speed cannot be set or if the cruise control cancels immediately after being activated, there may be a malfunction in the cruise control system. Have

the vehicle inspected by authorized Lexus retailer or Lexus authorized repairer, or any reliable repairer.

⚠ WARNING

■ **To avoid operating the cruise control by mistake**

Switch the cruise control off using the cruise control main switch when not in use.

■ **Situations unsuitable for cruise control**

Do not use cruise control in any of the following situations. Doing so may result in loss of control and could cause an accident resulting in death or serious injury.

- In heavy traffic
- On roads with sharp bends
- On winding roads
- On slippery roads, such as those covered with rain, ice or snow
- On steep downhill
Vehicle speed may exceed the set speed when driving down a steep hill.
- When your vehicle is towing a trailer or during emergency towing

Stop & Start system

The Stop & Start system stops and restarts the engine according to the brake pedal or shift lever operation when the vehicle is stopped.

Stop & Start system operation

■ **When the brake hold system is not operating**

▶ Stopping the engine

While driving with the shift lever in D, depress the brake pedal and stop the vehicle.

The Stop & Start indicator will come on.

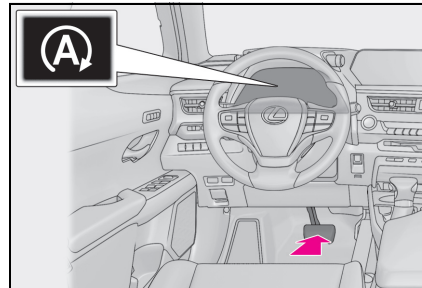

▶ Restarting the engine

Release the brake pedal.

The Stop & Start indicator will turn off.

■ **When the brake hold system is operating**

The Stop & Start system is operational when the brake hold system is operating. (→P.228)

▶ Stopping the engine

While driving with the shift lever in D, depress the brake pedal and stop the

vehicle.

The Stop & Start indicator will come on.

While the brake hold system is operating, the brake hold operated indicator will come on. If the brake pedal is released, the engine will remain stopped by the Stop & Start system.

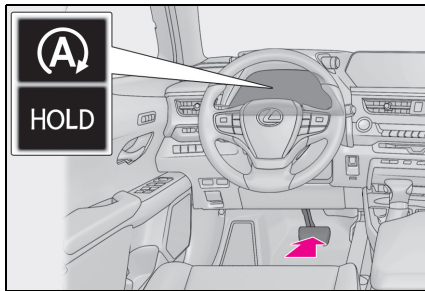

► Restarting the engine

Depress the accelerator pedal. (Releasing the brake pedal will not restart the engine.)

The Stop & Start indicator and brake hold operated indicator will turn off.

■ **When the dynamic radar cruise control with full-speed range is operating (if equipped)**

The Stop & Start system is operational during a controlled stop by the dynamic radar cruise control with full-speed range. (→P.284)

► Stopping the engine

While driving with the dynamic radar cruise control with full-speed range in vehicle-to-vehicle distance control mode, the engine will stop automatically if the vehicle comes to a complete stop through a controlled stop. (The engine will stop automatically even though the brake pedal is not

depressed.)

The Stop & Start indicator will come on.

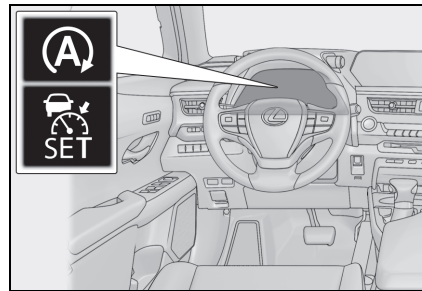

► Restarting the engine

When the preceding vehicle starts off, the engine will restart automatically.

The Stop & Start indicator will turn off.

■ **Operating conditions**

- The Stop & Start system is operational when all of the following conditions are met:
 - The brake pedal is being depressed firmly. (Except when the vehicle comes to a controlled stop while driving with the dynamic radar cruise control with full-speed range in vehicle-to-vehicle distance control mode)
 - The engine is adequately warmed up.
 - The outside temperature is -5°C (23°F) or higher.
 - The shift lever is in D.
 - When the driving mode (→P.337) is set to Normal mode or Eco drive mode.
 - The windshield defogger is off.
 - The hood is closed.
 - The driver's seat belt is fastened.
 - The driver's door is closed.
 - The accelerator pedal is not being depressed.
- In the following situations the engine may not be stopped by the Stop & Start system. This is not a malfunction of the Stop & Start system.
 - The air conditioning system is being used when the ambient temperature is high or low.

- The battery is not sufficiently charged, such as if the vehicle has been parked for a long time and the battery charge has decreased, the electric load is large, the battery fluid temperature is excessively low or the battery has deteriorated, or is undergoing a periodic recharge.
 - The brake booster vacuum is low.
 - The vehicle is stopped on a steep incline.
 - The steering wheel is being operated.
 - Due to traffic or other circumstances the vehicle is stopped repeatedly.
 - The vehicle is being driven in a high altitude area.
 - Engine coolant temperature or transmission fluid temperature is extremely low or high.
 - The battery fluid temperature is extremely low or high.
 - For a while after the battery terminals have been disconnected and reconnected.
 - For a while after the battery has been replaced.
 - The RSA system (→P.277) recognizes a stop sign and the vehicle is stopped.
 - In the following situations, the engine will restart automatically if the engine is stopped by the Stop & Start system. (To enable stopping of the engine by the Stop & Start system, drive the vehicle.)
 - The air conditioning system is turned on.
 - The pollen removal mode is turned on.
 - The windshield defogger is turned on.
 - The steering wheel is operated.
 - The shift lever is shifted to P, M, N or R from D.
 - The driver's seat belt is unfastened.
 - The driver's door is opened.
 - The accelerator pedal is depressed.
 - The Stop & Start cancel switch is pressed.
 - The vehicle starts to roll on an incline.
 - When the driving mode (→P.337) is set to other than Normal mode or Eco drive mode.
 - In the following situations, the engine may restart automatically if the engine is stopped by the Stop & Start system. (To enable stopping of the engine by the Stop & Start system, drive the vehicle.)
 - The brake pedal is pumped or strongly depressed.
 - The air conditioning system is being used.
 - The battery is not sufficiently charged.
- **Stop & Start system operation when the brake hold system is operating**
- If the engine is restarted automatically by the Stop & Start system when the brake hold system is operating, the brake hold system will continue to apply the brakes.
 - If the operation conditions of the brake hold system are no longer met (→P.228) while the engine is stopped by the Stop & Start system, the brake hold system will stop operating.
- At this time, the parking brake will be applied automatically and the engine will be restarted automatically.
- **Stop & Start system operation during a controlled stop by the dynamic radar cruise control with full-speed range (if equipped)**
- If the engine is restarted automatically by the Stop & Start system during a controlled stop by the dynamic radar cruise control with full-speed range, the controlled stop will continue. (Resuming follow-up cruising after a controlled stop:→P.287)
- **Hood**
- If the hood is opened while the engine is stopped by the Stop & Start system, the engine will stall and will not be able to be restarted by the automatic engine start function. In this case, restart the engine using the normal engine starting procedure. (→P.217)
 - Even if the hood is closed after the engine is started with the hood open, the Stop & Start system will not operate. Close the hood, turn the engine switch off, wait 30 seconds or more, and then start the engine.
- **When to use the Stop & Start system**
- When stopping the vehicle for a longer period of time, turn the engine switch off and stop the engine completely.
 - When the system does not operate, is canceled, or is malfunctioning, warning messages and a warning buzzer are used

to inform the driver. (→P.298)

- If the engine switch is pressed when the engine is stopped by the Stop & Start system, the engine will stall and will not be able to be restarted by the automatic engine start function. In this case, restart the engine using the normal engine starting procedure. (→P.217)
- When the engine is restarted by the Stop & Start system, the power outlet may be temporarily unusable, but this is not a malfunction.
- Installation and removal of electrical components and wireless devices may affect the Stop & Start system. Contact any authorized Lexus retailer or Lexus authorized repairer, or any reliable repairer for details.

■ If the windshield is fogged up while the engine is stopped by the Stop & Start system

Turn the windshield defogger on. (The engine will start due to the automatic engine start function.): →P.356

If the windshield fogs up frequently, press the Stop & Start cancel switch to disable the system.

■ Air conditioning system operation while the engine is stopped by the Stop & Start system











- If the air conditioning system is being used in automatic mode, the fan speed may be reduced or the fan may be stopped while the engine is stopped by the Stop & Start system in order to reduce changes in the cabin temperature.
- To ensure air conditioning system performance when the vehicle is stopped, disable the Stop & Start system by pressing the Stop & Start cancel switch.

■ If an odor comes from the air conditioning system while the engine is stopped by the Stop & Start system

Press the Stop & Start cancel switch to deactivate the Stop & Start system.

■ Changing the idling stop time with the air conditioning system on

The length of time the Stop & Start system will operate when the air conditioning system is on can be changed by performing the following operation. (The length of time the Stop & Start system will operate when the air conditioning system is off cannot be changed.)

- 1 Press  or  of the meter control switches and select .
- 2 Press  or  of the meter controls switches, select "Vehicle Settings", and then press "OK".
- 3 Press  or  of the meter controls switches, select  and then press "OK".
- 4 Press  or  of the meter controls switches, select "Standard" or "Extended", and then press "OK".

■ The Stop & Start system protection function

- When the volume of the audio system is excessively high, sound output from the audio system may suddenly be cut off in order to reduce battery consumption. To prevent the audio system from being cut off, keep the volume of audio system at a moderate level.
If the audio system has been cut off, turn the engine switch off, wait for 3 seconds or more and then turn it to ACC or ON to re-enable the audio system.
- The audio system may not be activated if the battery terminals are disconnected and then reconnected. If this occurs, turn the engine switch off and then repeat the following operation twice to activate the audio system normally.
 - Turn the engine switch to ON and then to off.

■ Replacing the battery

→P.484

■ **Displaying the Stop & Start system status**

→ P.109, 114

■ **Multi-information display messages**

If the following situations,  and a message may be displayed on the multi-information display.

- When the engine cannot be stopped by the Stop & Start system

 **“Press Brake More to Active”**

- The brake pedal is not depressed enough.

→ If the brake pedal is depressed further, the system will operate.

 **“For Climate Control”**

- The air conditioning system is being used when the ambient temperature is high or low.

→ If the difference between the set temperature and cabin temperature is small, the system will be enabled.

- The windshield defogger is ON.

 **“Non-Dedicated Battery”**

- A non-dedicated battery for the Stop & Start system may have been installed.

→ The Stop & Start system does not operate. Have the vehicle inspected by any authorized Lexus retailer or Lexus authorized repairer, or any reliable repairer.

 **“Battery Charging”**

- The battery charge amount may be low.

→ Engine stop is temporarily prohibited to prioritize charging of the battery, but if the engine is operated for a short while, engine stop is allowed.

- A refresh charge may be occurring, such as when the battery is undergoing a periodic recharge, for a while after the battery terminals have been disconnected and reconnected, for a while after the

battery has been replaced, etc.

→ After a refresh charge of approximately 5 to 60 minutes completes, the system can be operated.

- Continuously displayed for a long term
- The battery may be deteriorated. Contact any authorized Lexus retailer or Lexus authorized repairer, or any reliable repairer for details.

 **“Stop & Start Unavailable”**

- The Stop & Start system is temporarily disabled.

→ Operate the engine for a short while.

- The engine may have been started with the hood open.

→ Close the hood, turn the engine switch off, wait for 30 seconds or more, and then start the engine.

 **“Preparing to Operate”**

- The vehicle is being driven in a high altitude area.
- The brake booster vacuum is low.

→ When the brake booster vacuum reaches a predetermined level, the system will be enabled.

- When the engine automatically restarts while stopped by the Stop & Start system

 **“Preparing to Operate”**

- The brake pedal has been depressed further or pumped.

→ The system will be enabled after the engine runs and the brake booster vacuum reaches a predetermined level.

 **“For Climate Control”**

- The air conditioning system has been turned on or is being used.
- The windshield defogger has been turned on.

 **“Battery Charging”**

- The battery charge amount may be low.
→ The engine is restarted to prioritize battery charging. Operating the engine for a short while allows the system to recover.

■ Stop & Start system warning messages

If a system malfunction occurs, a warning message will be displayed on the multi-information display to inform the driver of the need for caution. (→P.452)

■ If the Stop & Start cancel indicator continues to flash

The system may be malfunctioning. Have the vehicle inspected by any authorized Lexus retailer or Lexus authorized repairer, or any reliable repairer.

WARNING

■ When the Stop & Start system is operating

- Depress the brake pedal and apply the parking brake when necessary while the engine is stopped by the Stop & Start system (while the Stop & Start indicator is on). (Except when the brake hold system is operating or when the vehicle comes to a controlled stop while driving with the dynamic radar cruise control with full-speed range in vehicle-to-vehicle distance control mode)
- Do not allow anyone to leave the vehicle while the engine is stopped by the Stop & Start system (while the Stop & Start indicator is on).
An accident may occur due to the automatic engine start function.
- Ensure that the engine is not stopped by the Stop & Start system while the vehicle is in a poorly ventilated area.
The engine may restart due to the automatic engine start function, causing exhaust gases to collect and enter the vehicle, possibly resulting in death or a serious health hazard.

NOTICE

■ To ensure the system operates correctly

If any of the following situations occur, the Stop & Start system may not operate correctly. Have your vehicle checked by any authorized Lexus retailer or Lexus authorized repairer, or any reliable repairer.

- While the driver's seat belt is fastened, the driver's and front passenger's seat belt reminder light flashes.
- Even though the driver's seat belt is not fastened, the driver's and front passenger's seat belt reminder light does not illuminate.
- Even though the driver's door is closed, the open door warning light is illuminated or the interior light is illuminated when the interior light switch is in the door position.
- Even though the driver's door is open, the open door warning light does not illuminate or the interior light does not illuminate when the interior light switch is in the door position.

Disabling the Stop & Start system

Press the Stop & Start cancel switch to disable the Stop & Start system.

The Stop & Start cancel indicator will come on.

Pressing the switch again will enable the Stop & Start system and the Stop & Start cancel indicator will turn off.

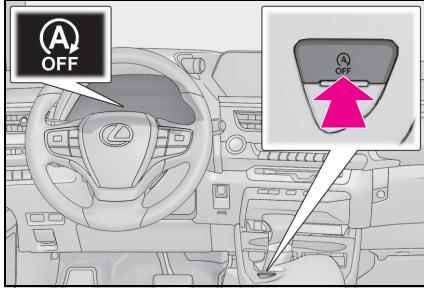

- Sound may be generated from the brakes, but this is not a malfunction.
- Brake pedal response may change and vibration may occur, but these are not malfunctions.

■ Automatic reactivation of the Stop & Start system

Even if the Stop & Start system is disabled by the Stop & Start cancel switch, it will be automatically re-enabled once the engine switch is turned off and then the engine is started.

■ If the Stop & Start cancel switch is pressed while the vehicle is stopped

- When the engine is stopped by the Stop & Start system, pressing the Stop & Start cancel switch will restart the engine.
- With the Stop & Start system disabled, pressing the Stop & Start cancel switch will re-enable the system but not stop the engine.
From the next time the vehicle is stopped (after Stop & Start system has been enabled), the engine will be stopped.

Hill-start assist control

After the engine is stopped by the Stop & Start system when the vehicle is on an incline, brake force is temporarily maintained to prevent rolling backwards until the engine is restarted and drive force is generated.

When drive force is generated, the maintained brake force is automatically canceled.

- This function operates on flat surfaces as well as steep inclines.

BSM (Blind Spot Monitor)*

*: If equipped

The Blind Spot Monitor is a system that uses rear side radar sensors installed on the inner side of the rear bumper on the left and right side to assist the driver in confirming safety when changing lanes.

! WARNING**■ Cautions regarding the use of the system**

The driver is solely responsible for safe driving. Always drive safely, taking care to observe your surroundings.

The Blind Spot Monitor is a supplementary function which alerts the driver that a vehicle is in a blind spot of the outside rear view mirrors or is approaching rapidly from behind into a blind spot. Do not overly rely on the Blind Spot Monitor. As the function cannot judge if it is safe to change lanes, over reliance could lead to an accident resulting in death or serious injury.

As the system may not function correctly under certain conditions, the driver's own visual confirmation of safety is necessary.

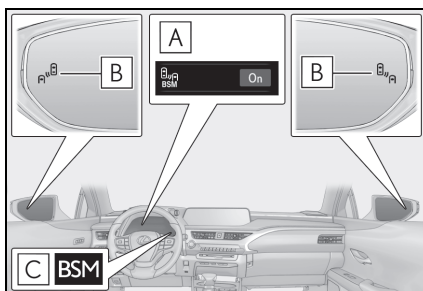
System components**A** Multi-information display

The Blind Spot Monitor can be turned on/off.

B Outside rear view mirror indicators

When a vehicle is detected in a blind spot of the outside rear view mirrors or approaching rapidly from behind into a blind spot, the outside rear view mirror indicator on the detected side will illuminate. If the turn signal lever is operated toward the detected side, the outside rear view mirror indicator flashes.

C BSM indicator

Illuminates when the Blind Spot Monitor is enabled

■ Outside rear view mirror indicator visibility

In strong sunlight, the outside rear view mirror indicator may be difficult to see.

■ When "Blind Spot Monitor Unavailable" is shown on the multi-information display

Ice, snow, mud, etc., may be attached to the rear bumper around the sensors. (→P.309) The system should return to normal operation after removing the ice, snow, mud, etc. from the rear bumper. Additionally, the sensors may not operate normally when driving in extremely hot or cold environments.

■ Customization

Some functions can be customized. (→P.510)

■ Certification

<p>Transmitter: Model: DNSRR004 Operation frequency: 24.15 GHz Maximum output power: 20 mW or less</p> <p>Manufacturer: DENSO CORPORATION</p> <p>Address: 1-1, Showa-cho, Kariya-shi, Aichi-ken, 448-8661 Japan</p>
<p>Hereby, DENSO CORPORATION declares that the radio equipment type is in compliance with Directive 2014/53/EU. The full text of the EU declaration of conformity is available at the following internet address: https://www.denso.com/global/en/contact-us/doc/</p> <p style="text-align: right;">01</p>
<p>DENSO CORPORATION vakuuttaa, että radiolaitetyyppi on direktiivin 2014/53/EU mukainen. EU-vaatimustenmukaisuusvakuutuksen täysimittainen teksti on saatavilla seuraavassa internetosoitteessa: https://www.denso.com/global/en/contact-us/doc/</p> <p style="text-align: right;">02</p>
<p>Hierbij verklaar ik, DENSO CORPORATION, dat het type radioapparatuur conform is met Richtlijn 2014/53/EU. De volledige tekst van de EU-conformiteitsverklaring kan worden geraadpleegd op het volgende internetadres: https://www.denso.com/global/en/contact-us/doc/</p> <p style="text-align: right;">03</p>
<p>Le soussigné, DENSO CORPORATION, déclare que l'équipement radioélectrique du type est conforme à la directive 2014/53/UE. Le texte complet de la déclaration UE de conformité est disponible à l'adresse internet suivante: https://www.denso.com/global/en/contact-us/doc/</p> <p style="text-align: right;">04</p>

Härmed försäkrar DENSO CORPORATION att denna typ av radioutrustning överensstämmer med direktiv 2014/53/EU. Den fullständiga texten till EU-försäkran om överensstämmelse finns på följande webbadress: https://www.denso.com/global/en/contact-us/doc/	05
Hermed erklærer DENSO CORPORATION, at radioudstyrstypen er i overensstemmelse med direktiv 2014/53/EU. EU-overensstemmelseserklæringens fulde tekst kan findes på følgende internetadresse: https://www.denso.com/global/en/contact-us/doc/	06
Hiermit erklärt DENSO CORPORATION, dass der Funkanlagentyp der Richtlinie 2014/53/EU entspricht. Der vollständige Text der EU-Konformitätserklärung ist unter der folgenden Internetadresse verfügbar: https://www.denso.com/global/en/contact-us/doc/	07
Με την παρούσα ο/η DENSO CORPORATION, δηλώνει ότι ο ραδιοεξοπλισμός πληροί την οδηγία 2014/53/ΕΕ. Το πλήρες κείμενο της δήλωσης συμμόρφωσης ΕΕ διατίθεται στην ακόλουθη ιστοσελίδα στο διαδίκτυο: https://www.denso.com/global/en/contact-us/doc/	08
Il fabbricante, DENSO CORPORATION, dichiara che il tipo di apparecchiatura radio è conforme alla direttiva 2014/53/UE. Il testo completo della dichiarazione di conformità UE è disponibile al seguente indirizzo Internet: https://www.denso.com/global/en/contact-us/doc/	09

Por la presente, DENSO CORPORATION declara que el tipo de equipo radioeléctrico es conforme con la Directiva 2014/53/UE. El texto completo de la declaración UE de conformidad está disponible en la dirección Internet siguiente:
<https://www.denso.com/global/en/contact-us/doc/>

10

O(a) abaixo assinado(a) DENSO CORPORATION declara que o presente tipo de equipamento de rádio está em conformidade com a Diretiva 2014/53/UE. O texto integral da declaração de conformidade está disponível no seguinte endereço de Internet:
<https://www.denso.com/global/en/contact-us/doc/>

11

B'dan, DENSO CORPORATION, niddikjara li dan it-tip ta' tagħmir tar-radju huwa konformi mad-Direttiva 2014/53/UE. It-test kollu tad-dikjarazzjoni ta' konformità tal-UE huwa disponibbli f'dan l-indirizz tal-Internet li ġej:
<https://www.denso.com/global/en/contact-us/doc/>

12

Käesolevaga deklareerib DENSO CORPORATION, et käesolev raadioseadme tüüp vastab direktiivi 2014/53/EL nõuetele. ELi vastavusdeklaratsiooni täielik tekst on kättesaadav järgmisel internetiaadressil:
<https://www.denso.com/global/en/contact-us/doc/>

13

DENSO CORPORATION igazolja, hogy a típusú rádióberendezés megfelel a 2014/53/EU irányelvnek. Az EU-megfelelőségi nyilatkozat teljes szövege elérhető a következő internetes címen:
<https://www.denso.com/global/en/contact-us/doc/>

14

DENSO CORPORATION týmto vyhlasuje, že rádiové zariadenie typu je v súlade so smernicou 2014/53/EÚ. Úplné EÚ vyhlásenie o zhode je k dispozícii na tejto internetovej adrese: https://www.denso.com/global/en/contact-us/doc/	15
Týmto DENSO CORPORATION prohlašuje, že typ rádiového zariadení je v souladu se směrnicí 2014/53/EU. Úplné znění EU prohlášení o shodě je k dispozici na této internetové adrese: https://www.denso.com/global/en/contact-us/doc/	16
DENSO CORPORATION potvrdzuje, da je tip radijske opreme skladen z Direktivo 2014/53/EU. Celotno besedilo izjave EU o skladnosti je na voljo na naslednjem spletnem naslovu: https://www.denso.com/global/en/contact-us/doc/	17
Aš, DENSO CORPORATION, patvirtinu, kad radijo įrenginių tipas atitinka Direktyvą 2014/53/ES. Visas ES atitikties deklaracijos tekstas prieinamas šiuo interneto adresu: https://www.denso.com/global/en/contact-us/doc/	18
Ar šo DENSO CORPORATION deklarē, ka radioiekārta atbilst Direktīvai 2014/53/ES. Pilns ES atbilstības deklarācijas teksts ir pieejams šādā interneta vietnē: https://www.denso.com/global/en/contact-us/doc/	19

<p>DENSO CORPORATION niniejszym oświadcza, że typ urządzenia radiowego jest zgodny z dyrektywą 2014/53/UE. Pełny tekst deklaracji zgodności UE jest dostępny pod następującym adresem internetowym: https://www.denso.com/global/en/contact-us/doc/</p>	20
<p>Hér með lýsir DENSO CORPORATION yfir því að er í samræmi við grunnkröfur og aðrar kröfur, sem gerðar eru í tilskipun 2014/53/EU. Samræmisýfirlýsing er einnig aðgengileg á eftirfarandi vefslóð: https://www.denso.com/global/en/contact-us/doc/</p>	21
<p>DENSO CORPORATION erklærer at er i overensstemmelse med direktiv 2014/53/EU. Samsvarserklæringen i fulltekst er tilgjengelig på følgende internettadresse: https://www.denso.com/global/en/contact-us/doc/</p>	22
<p>С настоящото DENSO CORPORATION декларира, че този тип радиосъоръжение е в съответствие с Директива 2014/53/ЕС. Цялостният текст на ЕС декларацията за съответствие може да се намери на следния интернет адрес: https://www.denso.com/global/en/contact-us/doc/</p>	23
<p>Prin prezenta, DENSO CORPORATION declară că tipul de echipamente radio este în conformitate cu Directiva 2014/53/UE. Textul integral al declarației UE de conformitate este disponibil la următoarea adresă internet: https://www.denso.com/global/en/contact-us/doc/</p>	24

<p>DENSO CORPORATION ovime izjavljuje da je radijska oprema tipa u skladu s Direktivom 2014/53/EU. Cjeloviti tekst EU izjave o sukladnosti dostupan je na sljedećoj internetskoj adresi: https://www.denso.com/global/en/contact-us/doc/</p>	25
<p>Овиме, DENSO CORPORATION изјављује да је радио опрема тип усаглашена са Директивом 2014/53/EU. Цео текст ЕУ декларације о усаглашености доступан је на следећој интернет адреси: https://www.denso.com/global/en/contact-us/doc/</p>	26
<p>Amb aquest document, DENSO CORPORATION declara que el tipus d'equipament radioelèctric es conforme a la Directiva 2014/53/UE. El text complet de la declaració UE de conformitat està disponible en la següent adreça d'Internet: https://www.denso.com/global/en/contact-us/doc/</p>	27
<p>İşbu belge; DENSO CORPORATION telsiz ekipmanı tipinin 2014/53/AB sayılı Direktif'e uygun olduğunu beyan eder. AB uygunluk beyanının tam metni aşağıdaki internet adresinde mevcuttur: https://www.denso.com/global/en/contact-us/doc/</p>	28
<p>Nepermjet kesaj, DENSO CORPORATION, deklaroj qe ky DNSRR004 eshte ne pajtim me kerkesat thelbesore dhe dispozitat e tjera perkatese te Direktives 1999/5/EC.</p>	29



The latest "DECLARATION of CONFORMITY" (DoC) is available at the following address:
<https://www.denso.com/global/en/contact-us/doc/>

For Vehicles sold in Ukraine
MODEL: DNSRR004



טויוטה מוטור אירופה נולסא, שדרות דו בורגט 60-1140 בריסל,

בלגיה www.toyota-europe.com

מוצר : חיישן נסתר
סימן רשום : DENSO
ארץ ייצור : ראה מוצר
דגם : DNSRR004
שנת ייצור : ראה מוצר

⚠ WARNING**■ Handling the rear side radar sensor**

Blind Spot Monitor sensors are installed behind the left and right sides of the rear bumper respectively. Observe the following to ensure the Blind Spot Monitor can operate correctly.

- Keep the sensors and the surrounding areas on the rear bumper clean at all times.

If a sensor or its surrounding area on the rear bumper is dirty or covered with snow, the Blind Spot Monitor may not operate and a warning message (→P.301) will be displayed. In this situation, clear off the dirt or snow and drive the vehicle with the operation conditions of the BSM function (→P.311) satisfied for approximately 10 minutes. If the warning message does not disappear, have the vehicle inspected by any authorized Lexus retailer or Lexus authorized repairer, or any reliable repairer.

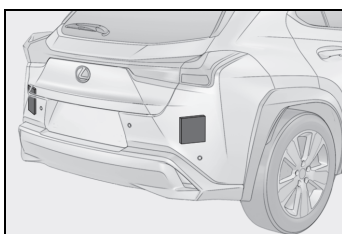

- Do not attach stickers to the sensor or surrounding area on the rear bumper.



- Do not subject a sensor or its surrounding area on the rear bumper to a strong impact.

If a sensor is moved even slightly off position, the system may malfunction and vehicles may not be detected correctly. In the following situations, have your vehicle inspected by any authorized Lexus retailer or Lexus authorized repairer, or any reliable repairer.

- A sensor or its surrounding area is subject to a strong impact.
- If the surrounding area of a sensor is scratched or dented, or part of them has become disconnected.
- Do not disassemble the sensor.
- Do not modify the sensor or surrounding area on the rear bumper.
- Do not paint the rear bumper any color other than an official Lexus color.

Turning the Blind Spot Monitor on/off

Use the meter control switches to turn on/off the function. (→P.117)

- 1 Press **<** or **>** to select .
- 2 Press **▲** or **▼** to select  and then press "OK".

Blind Spot Monitor operation

■ Vehicles that can be detected by the Blind Spot Monitor

The Blind Spot Monitor uses rear side radar sensors to detect the following vehicles traveling in adjacent lanes and advises the driver of the presence of such vehicles via the indicators on the outside rear view mirrors.

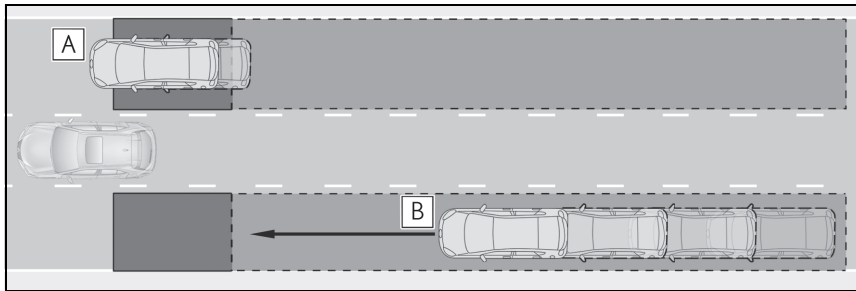

- A** Vehicles that are traveling in areas that are not visible using the outside rear view mirrors (the blind spots)
- B** Vehicles that are approaching rapidly from behind in areas that are not visible using the outside rear view mirrors (the blind spots)

■ The Blind Spot Monitor detection areas

The areas that vehicles can be detected in are outlined below.

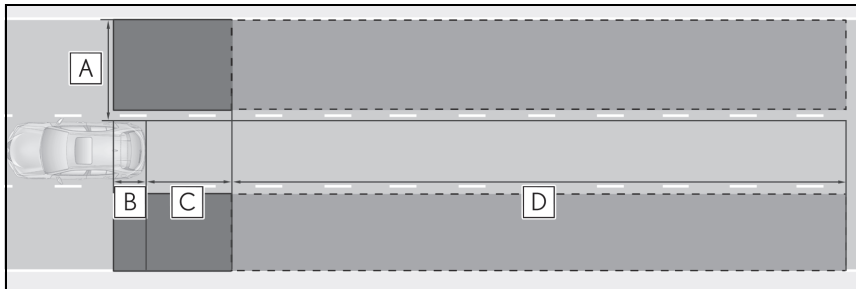

The range of each detection area is:

- A** Approximately 0.5 m (1.6 ft.) to 3.5 m (11.5 ft.) from either side of the vehicle^{*1}
- B** Approximately 1 m (3.3 ft.) forward of the rear bumper
- C** Approximately 3 m (9.8 ft.) from the rear bumper
- D** Approximately 3 m (9.8 ft.) to 60 m (197 ft.) from the rear bumper^{*2}

^{*1}: The area between the side of the vehicle and 0.5 m (1.6 ft.) from the side of the vehicle

cannot be detected.

^{*2}: The greater the difference in speed between your vehicle and the detected vehicle is, the farther away the vehicle will be detected, causing the outside rear view mirror indicator to illuminate or flash.

■ The Blind Spot Monitor is operational when

The Blind Spot Monitor is operational when all of the following conditions are met:

- The Blind Spot Monitor is on.
- The shift lever is in a position other than R.
- The vehicle speed is greater than approximately 16 km/h (10 mph).

■ The Blind Spot Monitor will detect a vehicle when

The Blind Spot Monitor will detect a vehicle present in the detection area in the following situations:

- A vehicle in an adjacent lane overtakes your vehicle.
- You overtake a vehicle in adjacent lane slowly.
- Another vehicle enters the detection area when it changes lanes.

■ Conditions under which the Blind Spot Monitor will not detect a vehicle

The Blind Spot Monitor is not designed to detect the following types of vehicles and/or objects:

- Small motorcycles, bicycles, pedestrians, etc. *
- Vehicles traveling in the opposite direction
- Guardrails, walls, signs, parked vehicles and similar stationary objects *
- Following vehicles that are in the same lane *
- Vehicles traveling 2 lanes away from your vehicle *
- Vehicles which are being overtaken rapidly by your vehicle *

* : Depending on the conditions, detection

of a vehicle and/or object may occur.

■ Conditions under which the Blind Spot Monitor may not function correctly

- The Blind Spot Monitor may not detect vehicles correctly in the following situations:
 - When the sensor is misaligned due to a strong impact to the sensor or its surrounding area
 - When mud, snow, ice, a sticker, etc. is covering the sensor or surrounding area on the rear bumper
 - When driving on a road surface that is wet with standing water during bad weather, such as heavy rain, snow, or fog
 - When multiple vehicles are approaching with only a small gap between each vehicle
 - When the distance between your vehicle and a following vehicle is short
 - When there is a significant difference in speed between your vehicle and the vehicle that enters the detection area
 - When the difference in speed between your vehicle and another vehicle is changing
 - When a vehicle enters a detection area traveling at about the same speed as your vehicle
 - As your vehicle starts from a stop, a vehicle remains in the detection area
 - When driving up and down consecutive steep inclines, such as hills, dips in the road, etc.
 - When driving on roads with sharp bends, consecutive curves, or uneven surfaces
 - When vehicle lanes are wide, or when driving on the edge of a lane, and the vehicle in an adjacent lane is far away from your vehicle
 - When an accessory (such as a bicycle carrier) is installed to the rear of the vehicle
 - When there is a significant difference in height between your vehicle and the vehicle that enters the detection area

- Immediately after the Blind Spot Monitor is turned on
- Instances of the Blind Spot Monitor unnecessarily detecting a vehicle and/or object may increase in the following situations:
 - When the sensor is misaligned due to a strong impact to the sensor or its surrounding area
 - When the distance between your vehicle and a guardrail, wall, etc. that enters the detection area is short
 - When driving up and down consecutive steep inclines, such as hills, dips in the road, etc.
 - When vehicle lanes are narrow, or when driving on the edge of a lane, and a vehicle traveling in a lane other than the adjacent lanes enters the detection area
 - When driving on roads with sharp bends, consecutive curves, or uneven surfaces
 - When the tires are slipping or spinning
 - When the distance between your vehicle and a following vehicle is short
 - When an accessory (such as a bicycle carrier) is installed to the rear of the vehicle

PKSA (Parking Support Alert)*

*: If equipped

The Parking Support Alert system consists of the following functions that operate when driving at a low speed or backing up, such as when parking. When the system determines that the possibility of a collision with a detected object, such as a wall is high, a warning operates to urge the driver to take evasive action.

PKSA (Parking Support Alert) system

- Lexus parking assist-sensor
(→P.313)
- RCTA(Rear Crossing TrafficAlert) function (if equipped)
(→P.320)





Setting the buzzer volume

■ Adjusting the buzzer volume

The buzzer volume can be adjusted on the multi-information display. The volume of buzzers for the Lexus parking assist-sensor and RCTA function will be adjusted simultaneously.

Use the meter control switches to change settings. (→P.117)

- 1 Press  or  to select .

- 2 Press  or  to select "PKSA" and then press "OK".
- 3 Press  or  to select  and then press "OK".

Each time the switch is pressed, the volume level will change between 1, 2, and 3.

■ Muting a buzzer temporarily

A mute button will be displayed on the multi-information display when an object or pedestrian is detected. To mute the buzzer, press "OK".

The buzzers for the Lexus parking assist-sensor and RCTA function will be muted simultaneously.

Mute will be canceled automatically in the following situations:

- When the shift lever is changed.
- When there is a malfunction in a sensor or the system is temporarily unavailable.
- When the operating function is disabled manually.
- When the engine switch is turned off.

Lexus parking assist-sensor*

*: If equipped

The distance from your vehicle to objects, such as a wall, when parallel parking or maneuvering into a garage is measured by the sensors and communicated via the multi-information display, head-up display (if equipped), Center Display and a buzzer. Always check the surrounding area when using this system.

System components

■ Types of sensors

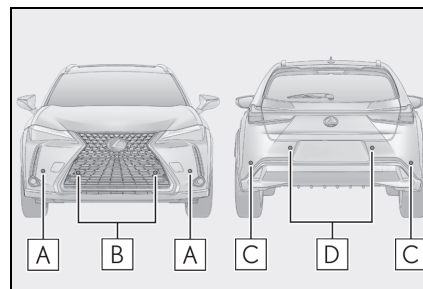

- A** Front corner sensors
- B** Front center sensors
- C** Rear corner sensors
- D** Rear center sensors

■ Display

When the sensors detect an object, such as a wall, a graphic is shown on the multi-information display, head-up display (if equipped) and Center Display (vehicles with 10.3-inch display

model) depending on the position and distance to the object.

- Multi-information display and head-up display

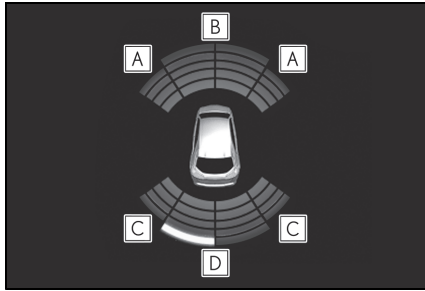

- A** Front corner sensor detection
- B** Front center sensor detection
- C** Rear corner sensor detection
- D** Rear center sensor detection

- Center Display

A graphic is shown when the Lexus parking assist monitor (if equipped) is displayed.

A simplified image is displayed on the Center Display when an object is detected.

- When the shift lever is in R

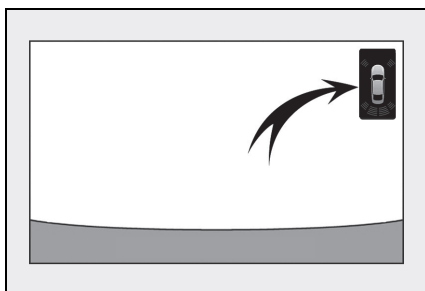

- When the shift lever is in N, M or D

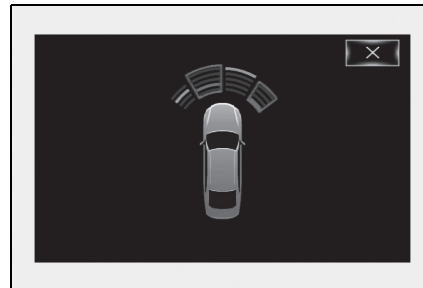

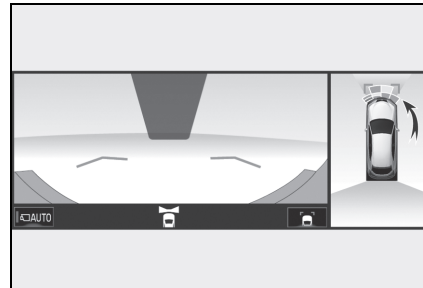

When an object is detected, a graphic will be displayed on the panoramic view monitor (if equipped).



Turning Lexus parking assist-sensor on/off

Use the meter control switches to enable/disable the Lexus parking assist-sensor. (→P.117)

- 1 Press **<** or **>** to select .
- 2 Press **▲** or **▼** to select "PKSA" and then press "OK".
- 3 Press **▲** or **▼** to select  and then press "OK".

When the Lexus parking assist-sensor function is disabled, the Lexus parking assist-sensor OFF indicator (→P.106) illuminates on the multi-information display.

When the Lexus parking assist-sensor function is turned on or off, operation of the Lexus parking assist-sensor function continues in the same condition the next time the engine is started.



WARNING

■ When using the Lexus parking assist-sensor

Observe the following precautions. Failing to do so may result in the vehicle being unable to be driven safely and possibly cause an accident.

- Do not use the sensor at speeds in excess of 10 km/h (6 mph).
- The sensors' detection areas and reaction times are limited. When moving forward or reversing, check the areas surrounding the vehicle (especially the sides of the vehicle) for safety, and drive slowly, using the brake to control the vehicle's speed.
- Do not install accessories within the sensors' detection areas.
- The area directly under the bumpers is not detected.

■ When to disable the function

In the following situations, disable the function as it may operate even though there is no possibility of a collision.

- The vehicle is equipped with a fender pole or wireless antenna.
- The front or rear bumper or a sensor receives a strong impact.
- A non-genuine Lexus suspension (lowered suspension, etc.) is installed.
- Towing eyelet is installed.
- A backlit license plate is installed.

■ When using Lexus parking assist-sensor

In the following situations, the system may not function correctly due to a sensor malfunction, etc. Have the vehicle checked by any authorized Lexus retailer or Lexus authorized repairer, or any reliable repairer.

- The Lexus parking assist-sensor operation display flashes or shows continuously, and a beep sounds when no objects are detected.
- If the area around a sensor collides with something, or is subjected to strong impact.
- If the bumper or grille collides with something.
- If the display flashes or is displayed continuously and a buzzer does not sound, except when the mute function has been turned on.
- If a display error occurs, first check the sensor.
If the error occurs even when there is no ice, snow or mud on the sensor, it is likely that the sensor is malfunctioning.

■ Notes when washing the vehicle

Do not apply intensive bursts of water or steam to the sensor area.

Doing so may result in the sensor malfunctioning.

- When using a high pressure washer to wash the vehicle, do not spray the sensors directly, as doing so may cause a sensor to malfunction.
- When using steam to clean the vehicle, do not direct steam too close to the sensors as doing so may cause a sensor to malfunction.

■ The system can be operated when

- The engine switch is in ON.
- Lexus parking assist-sensor function is on.
- The vehicle speed is less than about 10 km/h (6 mph).
- The shift lever is in other than P.

■ Setting the buzzer volume

The buzzer volume can be adjusted on the multi-information display. (→P.312)

■ If “Parking Assist Unavailable Clean Parking Assist Sensor” is displayed on the multi-information display

A sensor may be covered with ice, snow, dirt, etc. Remove the ice, snow, dirt, etc., from the sensor to return the system to normal.

Also, due to ice forming on a sensor at low temperatures, a warning message may be displayed or the sensor may not be able to detect an object. Once the ice melts, the system will return to normal.

■ Sensor detection information

- The sensor’s detection areas are limited to the areas around the vehicle’s front and rear bumpers.
- The following situations may occur during use.
 - Depending on the shape of the object and other factors, the detection distance may shorten, or detection may be impossible.
 - There will be a short delay between object detection and display. Even at low speeds, there is a possibility that the object will come within the sensor’s detection areas before the display is shown and the warning beep sounds.
 - It might be difficult to hear the buzzer due to the volume of the audio system or air flow noise of the air conditioning system.

■ Conditions under which the function may not function correctly

Certain vehicle conditions and the surrounding environment may affect the ability of a sensor to correctly detect objects. Par-

ticular instances where this may occur are listed below.

- There is dirt, snow or ice on a sensor. (Cleaning the sensors will resolve this problem.)
- A sensor is frozen. (Thawing the area will resolve this problem.)
In especially cold weather, if a sensor is frozen the sensor display may be displayed abnormally, or objects, such as a wall, may not be detected.
- A sensor is covered in any way.
- When a sensor or the area around a sensor is extremely hot or cold.
- On an extremely bumpy road, on an incline, on gravel, or on grass.
- The vicinity of the vehicle is noisy due to vehicle horns, motorcycle engines, air brakes of large vehicles, or other loud noises producing ultrasonic waves.
- There is another vehicle equipped with parking assist sensors in the vicinity.
- A sensor is coated with a sheet of spray or heavy rain.
- If a sensor is hit by a large amount of water, such as when driving on a flooded road.
- If the vehicle is significantly tilted.
- The vehicle is approaching a tall or curved curb.
- If objects draw too close to the sensor.

■ Objects which may not be properly detected

The shape of the object may prevent the sensor from detecting it. Pay particular attention to the following objects:

- Wires, fences, ropes, etc.
- Cotton, snow and other materials that absorb sound waves
- Sharply-angled objects
- Low objects
- Tall objects with upper sections projecting outwards in the direction of your vehicle

People may not be detected if they are wearing certain types of clothing.

Sensor detection display, object distance

■ **Detection range of the sensors**

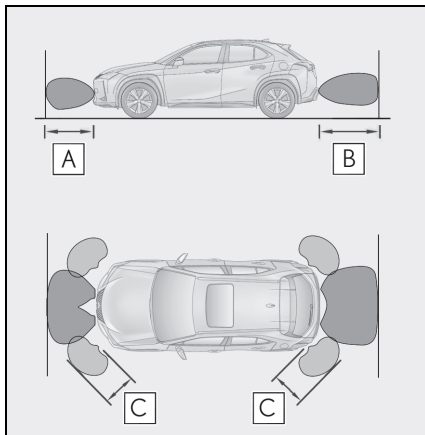

- A** Approximately 100 cm (3.3 ft.)
- B** Approximately 150 cm (4.9 ft.)
- C** Approximately 60 cm (2.0 ft.)

The diagram shows the detection range of the sensors. Note that the sensors cannot detect objects that are extremely close to the vehicle.

The range of the sensors may change depending on the shape of the object, etc.

■ **Multi-information display, head-up display (if equipped) and Center Display (vehicles with 10.3-inch display model)**



When an object is detected by a sensor, the approximate distance to the object will be displayed on the multi-information display, Center Display (vehicles with 10.3-inch display model), and head-up display (if equipped). (As the distance to the object becomes short, the distance segments may blink.)

- Approximate distance to object: 150 cm (4.9 ft.) to 60 cm (2.0 ft.)* (Rear center sensor)

Multi-information display	Center Display	Head-up display



*: Automatic buzzer mute function is enabled. (→P.319)

- Approximate distance to object: 100 cm (3.3 ft.) to 60 cm (2.0 ft.)* (Front center sensor)

Multi-information display	Center Display	Head-up display
		



*: Automatic buzzer mute function is enabled. (→P.319)

- Approximate distance to object: 60 cm (2.0 ft.) to 45 cm (1.5 ft.)*

Multi-information display	Center Display	Head-up display
		

*: Automatic buzzer mute function is enabled. (→P.319)

- Approximate distance to object: 45 cm (1.5 ft.) to 30 cm (1.0 ft.)*

Multi-information display	Center Display	Head-up display
		

*: Automatic buzzer mute function is enabled. (→P.319)



- Approximate distance to object: 30 cm (1.0 ft.) to 15 cm (0.5 ft.)^{*1}

Multi-information display ^{*2}	Center Display ^{*2}	Head-up display
		

^{*1}: Automatic buzzer mute function is disabled. (→P.319)

^{*2}: The distance segments will blink slowly.

- Approximate distance to object: Less than 15 cm (0.5 ft.)^{*1}

Multi-information display ^{*2}	Center Display ^{*2}	Head-up display
		

^{*1}: Automatic buzzer mute function is disabled. (→P.319)

^{*2}: The distance segments will blink rapidly.

■ Buzzer operation and distance to an object

A buzzer sounds when the sensors are operating.

- The buzzer beeps faster as the vehicle approaches an object. When the vehicle comes within the following distance of the object, the buzzer sounds continuously:

Approximately 30 cm (1.0 ft.)

- When 2 or more objects are detected simultaneously, the buzzer sounds for the nearest object. If one or more objects come within approximately 30 cm (1.0 ft.) of the vehicle, the buzzer will repeat a long tone, followed by fast beeps.
- Automatic buzzer mute function: After a buzzer begins sounding, if the distance between the vehicle and the detected object does not become shorter, the buzzer will be muted automatically. (However, if the distance between the vehicle and object is 30 cm (1.0 ft.) or less, this function will not operate.)

The buzzer sounds volume can be adjusted. (→P.312)

RCTA (Rear Crossing Traffic Alert) function*

*: If equipped

The RCTA function uses the BSM rear side radar sensors installed on the inner side of the rear bumper. This function is intended to assist the driver in checking areas that are not easily visible when backing up.

System components

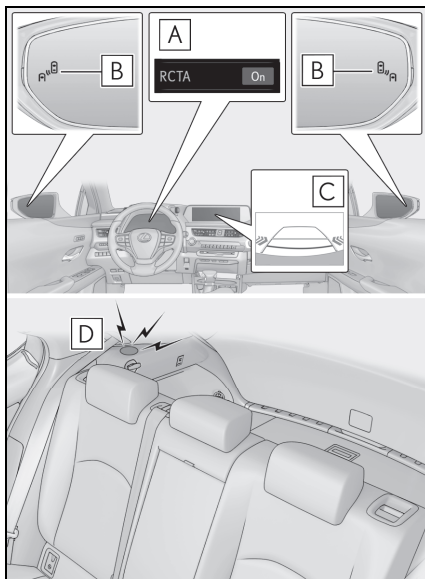

A Multi-information display

The RCTA function can be turned on/off. When the RCTA function is disabled, the RCTA OFF indicator illuminates.

B Outside rear view mirror indicators

When a vehicle approaching from the right or left at the rear of the vehicle is detected,

both outside rear view mirror indicators will flash.

C Center Display

If a vehicle approaching from the right or left at the rear of the vehicle is detected, the RCTA icon (→P.321) for the detected side will be displayed on the Center Display. This illustration shows an example of a vehicle approaching from both sides of the vehicle.

D RCTA buzzer

If a vehicle approaching from the right or left at the rear of the vehicle is detected, a buzzer will sound. The buzzer also sounds for approximately 1 second immediately after the RCTA function is turned on.

Turning the RCTA function on/off

Use the meter control switches to enable/disable the RCTA function. (→P.117)

- 1 Press **<** or **>** to select .
- 2 Press **▲** or **▼** to select "PKSA" and then press "OK".
- 3 Press **▲** or **▼** to select "RCTA" and then press "OK".

Each time the engine switch is turned off then changed to ON, the RCTA function will be enabled automatically.

⚠ WARNING**■ Cautions regarding the use of the function**

The driver is solely responsible for safe driving. Always drive safely, taking care to observe your surroundings.

The RCTA function is only a supplementary function which alerts the driver that a vehicle is approaching from the right or left at the rear of the vehicle. As the RCTA function may not function correctly under certain conditions, the driver's own visual confirmation of safety is necessary. Over reliance on this function may lead to an accident resulting death or serious injury.

■ Outside rear view mirror indicator visibility

In strong sunlight, the outside rear view mirror indicator may be difficult to see.

■ Hearing the RCTA buzzer

The RCTA buzzer may be difficult to hear over loud noises, such as if the audio system volume is high.

■ When "RCTA Unavailable" is shown on the multi-information display

Ice, water, snow, mud, etc., may be attached to the rear bumper around the sensors. (→P.309) Remove the ice, snow, mud, etc., attached to the rear bumper around the sensors to return the function to normal.

Additionally, the function may not operate normally when used in extremely hot or cold environments.

■ Rear side radar sensors

→P.309

RCTA function**■ Operation of the RCTA function**

The RCTA function uses rear side radar sensors to detect vehicles

approaching from the right or left at the rear of the vehicle and alerts the driver of the presence of such vehicles by flashing the outside rear view mirror indicators and sounding a buzzer.

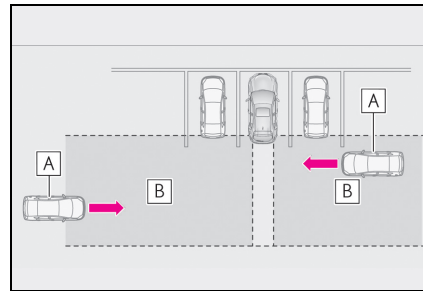

A Approaching vehicles

B Detection areas of approaching vehicles

■ RCTA icon display

When a vehicle approaching from the right or left at the rear of the vehicle is detected, the following will be displayed on the Center Display.

- Example (Lexus parking assist monitor) (if equipped): Vehicles are approaching from both sides of the vehicle

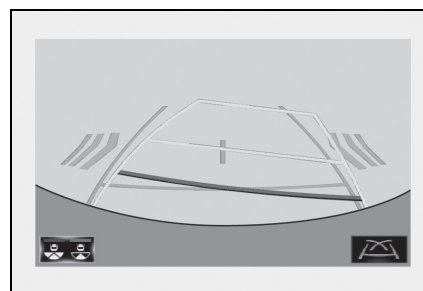
**■ RCTA function detection areas**

The areas that vehicles can be detected in are outlined below.

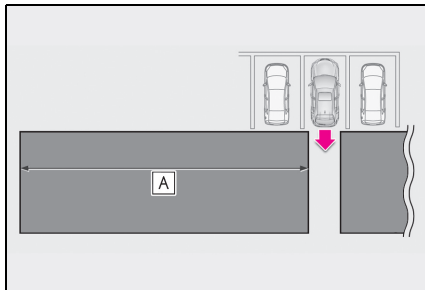

The buzzer can alert the driver of faster vehicles approaching from farther away.

Example:

Approaching vehicle speed	A Approximate alert distance
28 km/h (18 mph) (fast)	20 m (65 ft.)
8 km/h (5 mph) (slow)	5.5 m (18 ft.)

■ The RCTA function is operational when

The RCTA function operates when all of the following conditions are met:

- The engine switch is in ON.
- The RCTA function is on.
- The shift lever is in R.
- The vehicle speed is less than approximately 8 km/h (5 mph).
- The approaching vehicle speed is between approximately 8 km/h (5 mph) and 28 km/h (18 mph).

■ Setting the buzzer volume

The buzzer volume can be adjusted on the multi-information display. (→P.312)

■ Conditions under which the RCTA function will not detect a vehicle

The RCTA function is not designed to detect the following types of vehicles and/or objects:

- Vehicles approaching from directly behind
- Vehicles backing up in a parking space next to your vehicle
- Vehicles that the sensors cannot detect due to obstructions

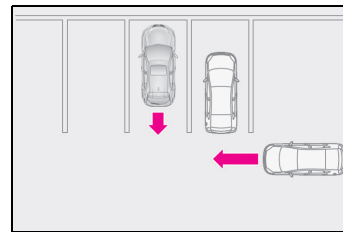

- Guardrails, walls, signs, parked vehicles and similar stationary objects*
- Small motorcycles, bicycles, pedestrians, etc.*
- Vehicles moving away from your vehicle
- Vehicles approaching from the parking spaces next to your vehicle*

*: Depending on the conditions, detection of a vehicle and/or object may occur.

■ Conditions under which the RCTA function may not function correctly

- The RCTA function may not detect vehicles correctly in the following situations:
 - When a sensor is misaligned due to a strong impact to the sensor or its surrounding area
 - When mud, snow, ice, a sticker, etc. is covering a sensor or its surrounding area on the rear bumper
 - When driving on a road surface that is wet with standing water during bad weather, such as heavy rain, snow, or fog
 - When multiple vehicles are approaching with only a small gap between each vehicle
 - If a vehicle is approaching the rear of your vehicle rapidly
 - When a towing eyelet is installed to the rear of the vehicle.
 - When backing up on a slope with a sharp change in grade

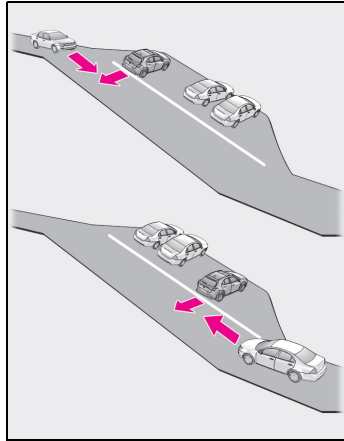

- When backing out of a shallow angle parking spot

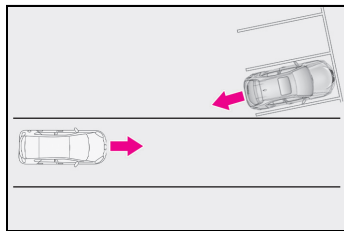

- Immediately after the RCTA function is turned on
- Immediately after the engine is started with the RCTA function on
- When the sensors cannot detect a vehicle due to obstructions

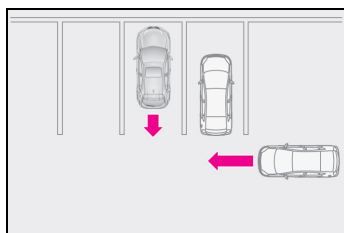

- Instances of the RCTA function unnecessarily detecting a vehicle and/or object may increase in the following situations:
 - When a vehicle passes by the side of your vehicle
 - When the parking space faces a street and vehicles are being driven on the street

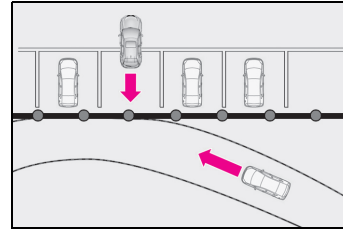

- When the distance between your vehicle and metal objects, such as a guardrail, wall, sign, or parked vehicle, which may reflect electrical waves toward the rear of the vehicle, is short
- When a towing eyelet is installed to the rear of the vehicle
- When a detected vehicle turns while approaching the vehicle

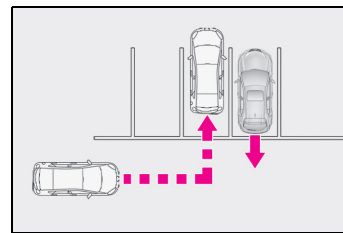

- When a vehicle passes by the side of your vehicle

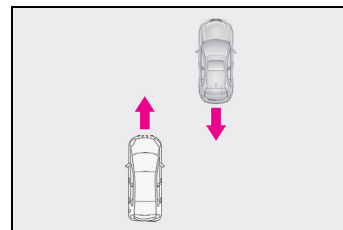

- When the distance between your vehicle and metal objects, such as a guardrail, wall, sign, or parked vehicle, which may reflect electrical waves toward the rear of the vehicle, is short

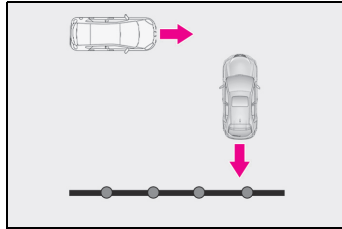

- When there are spinning objects near your vehicle such as the fan of an air conditioning unit
- When water is splashed or sprayed toward the rear bumper, such as from a sprinkler

PKSB (Parking Support Brake)*

*: If equipped

The Parking Support Brake system consists of the following functions that operate when driving at a low speed or backing up, such as when parking. When the system determines that the possibility of a collision with a detected object is high, a warning operates to urge the driver to take evasive action. If the system determines that the possibility of a collision with a detected object is extremely high, the brakes are automatically applied to help avoid the collision or help reduce the impact of the collision.

PKSB (Parking Support Brake) system

- Parking Support Brake function (static objects)
→P.328
- Parking Support Brake function (rear-crossing vehicles)
→P.333

WARNING

■ Limitations of the Parking Support Brake system

Do not overly rely on the system, as doing so may lead to an accident.

⚠ WARNING

- The driver is solely responsible for safe driving. Always drive carefully, taking care to observe your surroundings. The Parking Support Brake system is designed to provide support to lessen the severity of collisions. However, it may not operate in some situations.
- The Parking Support Brake system is not designed to stop the vehicle completely. Additionally, even if the system has stopped the vehicle, it is necessary to depress the brake pedal immediately as brake control will be canceled after approximately 2 seconds.

⚠ NOTICE







- If "Parking Support Brake Unavailable" is displayed on the multi-information display and the PKSB OFF indicator is flashing

If this message is displayed immediately after the engine switch is changed to ON, operate the vehicle carefully, paying attention to your surroundings.

Enabling/Disabling the Parking Support Brake

The Parking Support Brake can be enabled/disabled on the multi-information display. All of the Parking Support Brake functions (static objects and rear crossing vehicles) are enabled/disabled simultaneously.

Use the meter control switches to enable/disable the parking support brake. (→P.117)

- 1 Press  or  to select .
- 2 Press  or  to select  and then press "OK".

When the Parking Support Brake is disabled, the PKSB OFF indicator (→P.106) illuminates on the multi-information display.

When the Parking Support Brake is turned on or off, operation of the Parking Support Brake continues in the same condition the next time the engine is started.

Displays and buzzers for engine output restriction control and brake control

If the engine output restriction control or brake control operates, a buzzer will sound and a message will be displayed on the Center Display (Panoramic view monitor) and multi-information display, to alert the driver. On vehicles with head-up display, the head-up display will display the same message as the multi-information display.

Depending on the situation, engine output restriction control will operate to either limit acceleration or restrict output as much as possible.

- Engine output restriction control is operating (acceleration restriction)

Acceleration greater than a certain amount is restricted by the system.

Center Display (Panoramic view monitor): No warning displayed

Multi-information display: "Object Detected Acceleration Reduced"

PKSB OFF indicator: Not illuminated

Buzzer: Does not sound

- Engine output restriction control is operating (output restricted as much as possible)

The system has determined that stronger-than-normal brake operation is necessary.

Center Display (Panoramic view monitor):
"BRAKE!"

Multi-information display: "BRAKE!"

PKSB OFF indicator: Not illuminated

Buzzer: Short beep

- Brake control is operating

The system determined that emergency braking is necessary.

Center Display (Panoramic view monitor):
"BRAKE!"

Multi-information display: "BRAKE!"

PKSB OFF indicator: Not illuminated

Buzzer: Short beep

- Vehicle stopped by system operation

The vehicle has been stopped by brake control operation.

Center Display (Panoramic view monitor):
"Press Brake Pedal"

Multi-information display: "Switch to Brake" (If the accelerator pedal is not depressed, "Press Brake Pedal" will be displayed.)

PKSB OFF indicator: Illuminated

Buzzer: Short beep

System overview

If the Parking Support Brake determines that a collision with a detected object or pedestrian is possible, the engine output will be restricted to restrain any increase in the vehicle speed. (Engine output restriction control: See figure 2 below.)

Additionally, if the accelerator pedal continues to be depressed, the brakes

will be applied automatically to reduce the vehicle speed. (Brake control: See figure 3 below.)

- Figure 1 When the PKSB (Parking Support Brake) is disabled

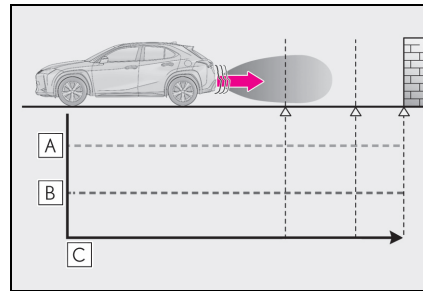

A Engine output

B Braking force

C Time

- Figure 2 When engine output restriction control operates

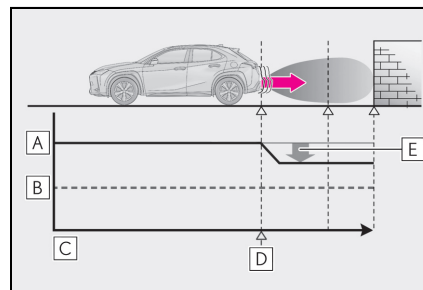

A Engine output

B Braking force

C Time

- D** Engine output restriction control begins operating (The system determines that possibility of collision with detected object is high)

"BRAKE!" is displayed on the multi-infor-

mation display.

E Engine output reduced

- Figure 3 When brake control operates

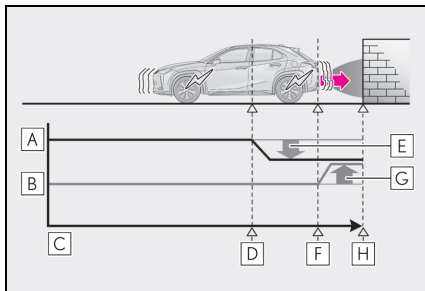

A Engine output

B Braking force

C Time

D Engine output restriction control begins operating (The system determines that possibility of collision with detected object is high)

"BRAKE!" is displayed on the multi-information display.

E Engine output reduced

F Brake control begins operating (the system determines that possibility of collision with detected object is extremely high)

G Brake control strength increased

H "Switch to Brake" is displayed on the multi-information display

■ If the Parking Support Brake has operated

If the vehicle is stopped due to operation of the Parking Support Brake, the Parking Support Brake will be disabled and the PKSBB OFF indicator will illuminate. If the

Parking Support Brake operates unnecessarily, brake control can be canceled by depressing the brake pedal or waiting for approximately 2 seconds for it to automatically be canceled. Then, the vehicle can be operated by depressing the accelerator pedal.

■ Re-enabling the Parking Support Brake

To re-enable the Parking Support Brake when it is disabled due to operation of the Parking Support Brake, either enable the system again (→P.325), or turn the engine switch off and then back to ON. Additionally, if the object becomes no longer in the traveling direction of the vehicle or if the traveling direction of the vehicle changes (such as changing from moving forward to backing up, or from backing up to moving forward), the system will be re-enabled automatically.

■ If "Parking Support Brake Unavailable" is displayed on the multi-information display and the PKSBB OFF indicator is flashing

If the vehicle is stopped due to operation of the Parking Support Brake, the Parking Support Brake will be disabled and the PKSBB OFF indicator will illuminate.

- A sensor may be covered with ice, snow, dirt, etc. Remove the ice, snow, dirt, etc., from the sensor to return the system to normal.

Also, due to ice forming on a sensor at low temperatures, a warning message may be displayed or the sensor may not be able to detect an object. Once the ice melts, the system will return to normal.

- The surrounding area of the sensors on the bumper may be dirty, or a sensor may be covered with ice, snow, dirt, etc. In this case, remove the ice, snow, dirt, etc. from the sensor or its surrounding area on the bumper to return the system to a normal state. At a low temperature, a warning message may be displayed or an object may not be detected due to freezing of the sensor. Once the ice melts, the system will return to normal.

- If this message continues to be displayed even after cleaning the sensor, or is dis-

played even though the sensor is clean, have the vehicle inspected by any authorized Lexus retailer or Lexus authorized repairer, or any reliable repairer.

- Initialization may not have been performed after a battery terminal was disconnected and reconnected. Initialize the system. (→P.328)
If this message continues to be displayed even after initialization, have the vehicle inspected by any authorized Lexus retailer or Lexus authorized repairer, or any reliable repairer.

■ **If a battery terminal has been disconnected and reconnected**

The system needs to be initialized. To initialize the system, drive the vehicle straight ahead for 5 seconds or more at a speed of approximately 35 km/h (22 mph) or more.

Parking Support Brake function (static objects)*

*: If equipped

If the sensors detect a static object, such as a wall, in the traveling direction of the vehicle and the system determines that a collision may occur due to the vehicle suddenly moving forward due to an accidental accelerator pedal operation, the vehicle moving the unintended direction due to the wrong shift position being selected, or while parking or traveling at low speeds, the system will operate to lessen the impact with the detected static object and reduce the resulting damage.

Examples of function operation

This function will operate in situations such as the following if an object is detected in the traveling direction of the vehicle.

- When traveling at a low speed and the brake pedal is not depressed, or is depressed late

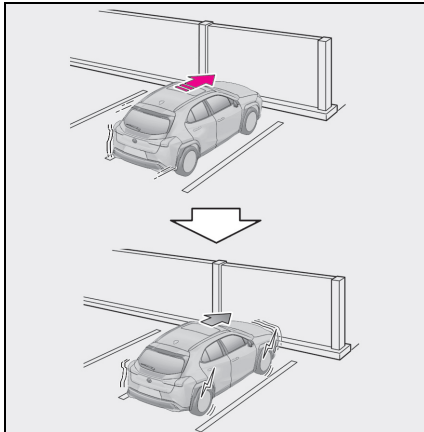

- When the accelerator pedal is depressed excessively

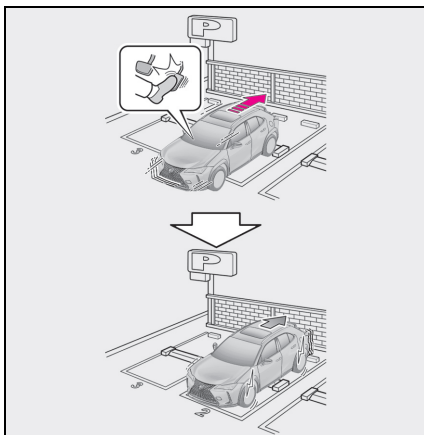

- When the vehicle moves in the unintended direction due to the wrong shift position being selected

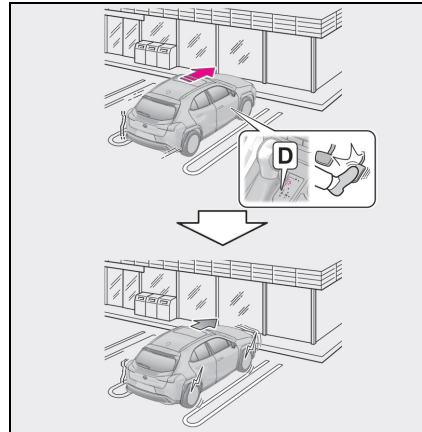

Types of sensors

→P.313

⚠ WARNING

- To ensure the Parking Support Brake can operate properly

Observe the following precautions regarding the sensors (→P.313). Failure to do so may cause a sensor to not operate properly, and may cause an accident.

- Do not modify, disassemble or paint the sensors.
- Do not replace a sensor with a part other than a genuine part.
- Do not subject a sensor or its surrounding area to a strong impact.
- Do not damage the sensors, and always keep them clean.

**WARNING**

- If the area around a radar sensor is subjected to an impact, the system may not operate properly due to a sensor malfunction. Have the vehicle inspected by any authorized Lexus retailer or Lexus authorized repairer, or any reliable repairer.

■ Handling the suspension

Do not modify the suspension, as changes to the height or inclination of the vehicle may prevent the sensors from detecting objects correctly or cause the system to not operate or operate unnecessarily.

■ If the Parking Support Brake function (static objects) operates unnecessarily, such as at a railroad crossing

In the event that the Parking Support Brake function (static objects) operates unnecessarily, such as at a railroad crossing, brake control will be canceled after approximately 2 seconds, allowing you to proceed forward and leave the area, brake control can also be canceled by depressing the brake pedal. Depressing the accelerator pedal after brake control is canceled will allow you to proceed forward and leave the area.

■ Notes when washing the vehicle

Do not apply intensive bursts of water or steam to the sensor area.

Doing so may result in the sensor malfunctioning.

- When using a high pressure washer to wash the vehicle, do not spray the sensors directly, as doing so may cause a sensor to malfunction.
- When using steam to clean the vehicle, do not direct steam too close to the sensors as doing so may cause a sensor to malfunction.

■ When to disable the Parking Support Brake (static objects)

In the following situations, disable the Parking Support Brake (static objects) as the system may operate even though there is no possibility of a collision.

- When inspecting the vehicle using a chassis roller, chassis dynamo or free roller
- When loading the vehicle onto a boat, truck or other transport vessel
- If the suspension has been modified or tires of a size other than specified are installed
- If the front of the vehicle is raised or lowered due to the carried load
- When equipment that may obstruct a sensor is installed, such as a towing eyelet, bumper protector (an additional trim strip, etc.), bicycle carrier, or snow plow
- When using an automatic car wash

■ The Parking Support Brake function (static object) will operate when

The function will operate when the PKSB OFF indicator is not illuminated or flashing (→P.105, 106) and all of the following conditions are met:

- Engine output restriction control
 - The Parking Support Brake is enabled.
 - The vehicle speed is 15 km/h (10 mph) or less.
 - There is a static object in the traveling direction of the vehicle and 2 to 4 m (6 to 13 ft.) away.
 - The Parking Support Brake determines that a stronger-than-normal brake operation is necessary to avoid a collision.
- Brake control
 - The Parking Support Brake determines that an immediate brake operation is necessary to avoid a collision.

■ The Parking Support Brake function (static objects) will stop operating when

The function will stop operating if any of the following conditions are met:

- Engine output restriction control
 - The Parking Support Brake is disabled.
 - The system determines that the collision has become avoidable with normal brake operation.
 - The static object is no longer 2 to 4 m (6 to 13 ft.) away from the vehicle or in the traveling direction of the vehicle.
- Brake control
 - The Parking Support Brake is disabled.
 - Approximately 2 seconds have elapsed since the vehicle was stopped by brake control.
 - The brake pedal is depressed after the vehicle is stopped by brake control.
 - The static object is no longer 2 to 4 m (6 to 13 ft.) away from the vehicle or in the traveling direction of the vehicle.

■ Detection range of the Parking Support Brake function (static objects)

The detection range of the Parking Support Brake function (static objects) differs from the detection range of the Lexus parking assist-sensor. (→P.317) Therefore, even if the Lexus parking assist-sensor detects an object and provides a warning, the Parking Support Brake function (static objects) may not start operating.

■ Objects that the Parking Support Brake function (static objects) may not detect

The sensors may not be able to detect certain objects, such as the following:

- Pedestrian
- Cotton cloth, snow, and other materials that are poor reflectors of ultrasonic waves
- Objects which are not perpendicular to the ground, are not perpendicular to the traveling direction of the vehicle, are uneven or are waving
- Low objects
- Thin objects such as wires, fences, ropes and signposts

- Objects that are extremely close to the bumper

■ Situations in which the Parking Support Brake function (static objects) may not operate

When driving with the shift lever in N

■ Lexus parking assist-sensor buzzer

Regardless of whether the Lexus parking assist-sensor function is enabled or not (→P.314), if the Parking Support Brake function (static objects) is enabled (→P.325), the front or rear sensors detect an object and engine output restriction control or brake control is performed, the Lexus parking assist-sensor buzzer will sound to notify the driver of the approximate distance to the object.

■ Situations in which the Parking Support Brake function (static objects) may operate even if there is no possibility of a collision

In some situations, such as the following, the Parking Support Brake function (static objects) may operate even though there is no possibility of a collision.

- Vehicle surroundings
 - When driving on a narrow road

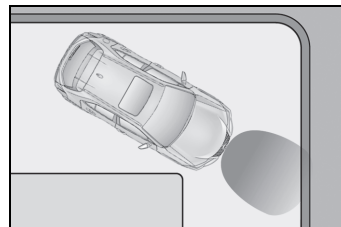

- When driving on a gravel road or in an area with tall grass

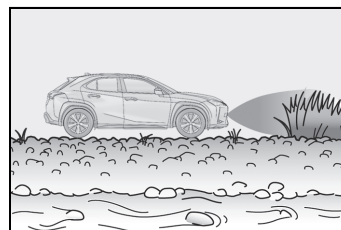

- When driving toward a banner, flag, low-

hanging branch or boom barrier (such as those used at railroad crossings, toll gates and parking lots)

- When driving on a narrow path surrounded by a structure, such as in a tunnel or on an iron bridge
- When parallel parking
- When there is a rut or hole in the surface of the road
- When driving on a metal cover (grating), such as those used for drainage ditches
- When driving on a steep slope
- If a sensor is hit by a large amount of water, such as when driving on a flooded road
- Weather
 - If a sensor is covered with ice, snow, dirt, etc. (when cleared, the system will return to normal)
 - If heavy rain or water strikes a sensor
 - When driving in inclement weather such as fog, snow or a sandstorm
- Other ultrasonic wave sources
 - When vehicle horns, vehicle detectors, motorcycle engines, air brakes of large vehicles, the clearance sonar of other vehicles or other devices which produce ultrasonic waves are near the vehicle
 - If a sticker or an electronic component, such as a backlit license plate (especially fluorescent type), fog lights, fender pole or wireless antenna is installed near a sensor
- Changes in the vehicle posture
 - If the vehicle is significantly tilted
 - If the front of the vehicle is raised or lowered due to the carried load
 - If the orientation of a sensor has been changed due to a collision or other impact

■ **Situations in which the Parking Support Brake function (static objects) may not operate properly**

In some situations, such as the following, this function may not operate properly.

- Weather
 - When a sensor or the area around a sensor is extremely hot or cold

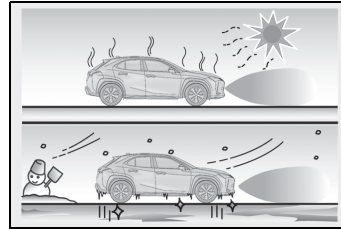

- When strong winds are blowing

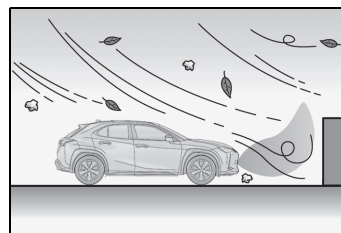

- If a sensor is covered with ice, snow, dirt, etc. (when cleared, the system will return to normal)
- If heavy rain or water strikes a sensor
- When driving in inclement weather such as fog, snow or a sandstorm
- Vehicle surroundings
 - When an object that cannot be detected is between the vehicle and a detected object
 - If an object such as a vehicle, motorcycle, bicycle or pedestrian cuts in front of the vehicle or runs out from the side of the vehicle
- Other ultrasonic waves sources
 - When vehicle horns, vehicle detectors, motorcycle engines, air brakes of large vehicles, the clearance sonar of other vehicles or other devices which produce ultrasonic waves are near the vehicle
 - If a sticker or an electronic component, such as a backlit license plate (especially fluorescent type), fog lights, fender pole or wireless antenna is installed near a sensor
- Changes in the vehicle posture
 - If the vehicle is significantly tilted
 - If the front of the vehicle is raised or lowered due to the carried load
 - If the orientation of a sensor has been changed due to a collision or other

impact

Parking Support Brake function (rear-crossing vehicles)*

*: If equipped

If a rear radar sensor detects a vehicle approaching from the right or left at the rear of the vehicle and the system determines that the possibility of a collision is high, this function will perform brake control to reduce the likelihood of an impact with the approaching vehicle.

Examples of function operation

This function will operate in situations such as the following if a vehicle is detected in the traveling direction of the vehicle.

- When reversing, a vehicle is approaching and the brake pedal is not depressed, or is depressed late

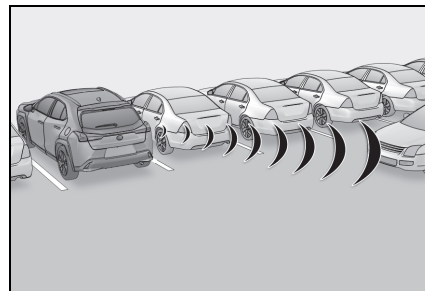

Types of sensors

→P.309

4

Driving

**WARNING****■ To ensure the Parking Support Brake (rear-crossing vehicles) can operate properly**

Observe the following precautions regarding the rear radar sensors (→P.309). Failure to do so may cause a sensor to not operate properly, and may cause an accident.

- Do not modify, disassemble or paint the sensors.
- Do not replace a rear radar sensor with a part other than a genuine part.
- Do not damage the rear radar sensors, and always keep the radar sensors and their surrounding area on the bumper clean.

■ To prevent a rear radar sensor from malfunctioning

- If the area around a rear radar sensor is subjected to an impact, the system may not operate properly due to a sensor malfunction. Have the vehicle inspected by any authorized Lexus retailer or Lexus authorized repairer, or any reliable repairer.
- Observe the rear radar sensor handling precautions. (→P.309)

■ The Parking Support Brake function (rear-crossing vehicles) will operate when

The function will operate when the PKSB OFF indicator is not illuminated or flashing (→P.105, 106) and all of the following conditions are met:

- Engine output restriction control
- The Parking Support Brake is enabled.
- The vehicle speed is 15 km/h (10 mph) or less.
- Vehicles which are approaching from the right or left at the rear of the vehicle at a traveling speed of more than approximately 8 km/h (5 mph)
- The shift lever is in R.

- The Parking Support Brake determines that a stronger than normal brake operation is necessary to avoid a collision with an approaching vehicle.

● Brake control

- The Parking Support Brake determines that an emergency brake operation is necessary to avoid a collision with an approaching vehicle.

■ The Parking Support Brake function (rear-crossing vehicles) will stop operating when

The function will stop operating if any of the following conditions are met:

- Engine output restriction control
 - The Parking Support Brake is disabled.
 - The collision becomes avoidable with normal brake operation.
 - A vehicle is no longer approaching from the right or left at the rear of the vehicle.
- Brake control
 - The Parking Support Brake is disabled.
 - Approximately 2 seconds have elapsed since the vehicle was stopped by brake control.
 - The brake pedal is depressed after the vehicle is stopped by brake control.
 - A vehicle is no longer approaching from the right or left at the rear of the vehicle.

■ Detection area of the Parking Support Brake function (rear-crossing vehicles)

The detection area of the Parking Support Brake function (rear-crossing vehicles) differs from the detection area of the RCTA function (→P.321). Therefore, even if the RCTA function detects a vehicle and provides an alert, the Parking Support Brake function (rear-crossing vehicles) may not start operating.

■ Conditions under which the Parking Support Brake function (rear-crossing vehicles) will not detect a vehicle

The Parking Support Brake function (rear-crossing vehicles) is not designed to detect the following types of vehicles and/or objects:

- Vehicles approaching from directly behind

- Vehicles backing up in a parking space next to your vehicle
- Vehicles that the sensors cannot detect due to obstructions

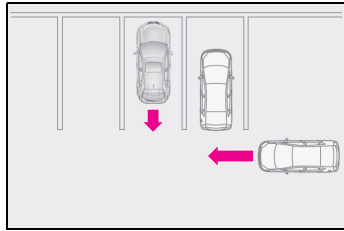

- Vehicles which suddenly accelerate or decelerate near your vehicle
- Guardrails, walls, signs, parked vehicles and similar stationary objects*
- Small motorcycles, bicycles, pedestrians, etc.*
- Vehicles moving away from your vehicle
- Vehicles approaching from the parking spaces next to your vehicle*
- Objects which are extremely close to a radar sensor*
- Vehicles which are approaching from the right or left at the rear of the vehicle at a traveling speed of less than approximately 8 km/h (5 mph)
- Vehicles which are approaching from the right or left at the rear of the vehicle at a traveling speed of more than approximately 24 km/h (15 mph)

*: Depending on the conditions, detection of a vehicle and/or object may occur.

■ RCTA buzzer

Regardless of whether the RCTA function is enabled or not (→P.320), if the Parking Support Brake function is enabled (→P.325) and brake control is performed, a buzzer will sound to notify the driver.

■ Situations in which the system may operate even though there is no possibility of a collision

In some situations such as the following, the Parking Support Brake function (rear-

crossing vehicles) may operate even though there is no possibility of a collision.

- When the parking space faces a street and vehicles are being driven on the street

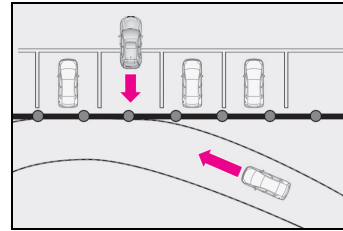

- When a detected vehicle turns while approaching the vehicle

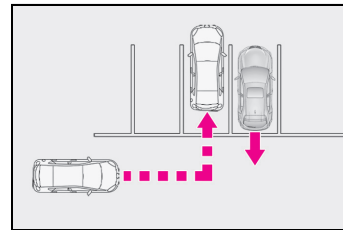

- When a vehicle passes by the side of your vehicle

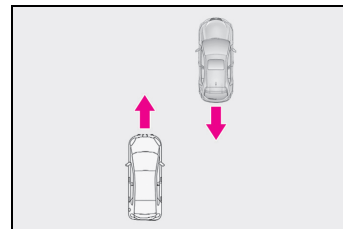

- When the distance between your vehicle and metal objects, such as a guardrail, wall, sign, or parked vehicle, which may reflect electrical waves toward the rear of the vehicle, is short

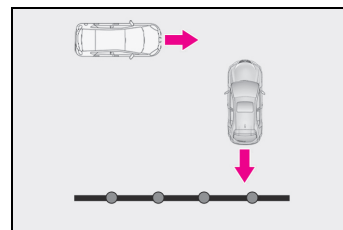

- When there are spinning objects near your vehicle such as the fan of an air conditioning unit
- When water is splashed or sprayed toward the rear bumper, such as from a sprinkler

■ **Situations in which the Parking Support Brake function (rear-crossing vehicles) may not operate properly**

In some situations, such as the following, the radar sensors may not detect an object and this function may not operate properly

- Stationary objects
- When a sensor or the area around a sensor is extremely hot or cold
- If the rear bumper is covered with ice, snow, dirt, etc.
- When it is raining heavily or water strikes the vehicle
- If the vehicle is significantly tilted
- When equipment that may obstruct a sensor is installed, such as a towing eyelet, bumper protector (an additional trim strip, etc.), bicycle carrier, or snow plow
- If the suspension has been modified or tires of a size other than specified are installed
- If the front of the vehicle is raised or lowered due to the carried load
- If a sticker or an electronic component, such as a backlit license plate (especially fluorescent type), fog lights, fender pole or wireless antenna is installed near a radar sensor
- If the orientation of a radar sensor has been changed
- When multiple vehicles are approaching with only a small gap between each vehicle
- If a vehicle is approaching the rear of your vehicle rapidly
- Situations in which the radar sensor may not detect a vehicle
- When a vehicle approaches from the right or left at the rear of the vehicle while you are turning while backing up

- When turning while backing up

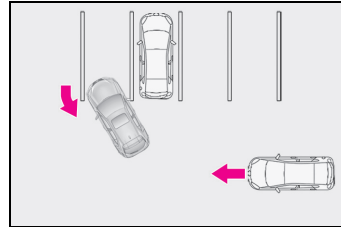

- When backing out of a shallow angle parking spot

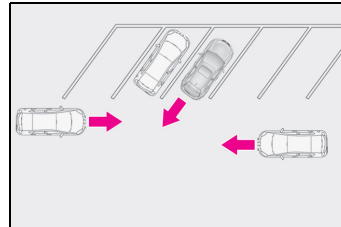

- When backing up on a slope with a sharp change in grade

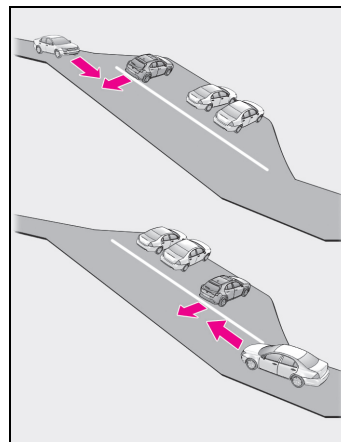

- When a vehicle turns into the detection area

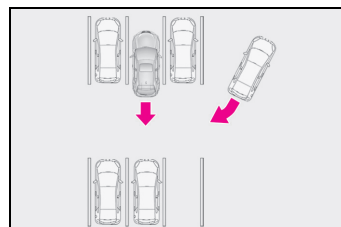

Driving mode select switch

The driving modes can be selected to suit driving conditions.

Selecting the driving mode

- ▶ Vehicles without Adaptive Variable Suspension system

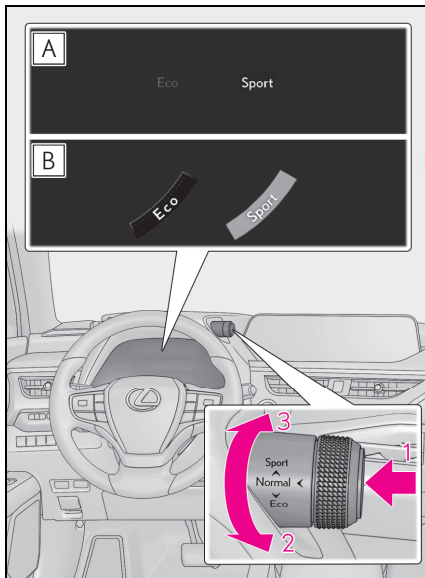

A Except F SPORT models

B F SPORT models

- 1** Normal mode
Provides an optimal balance of fuel economy, quietness, and dynamic performance. Suitable for city driving.

Press the switch to change the Normal mode when not in Normal mode.

- 2** Eco drive mode
Helps the driver accelerate in an eco-friendly manner and improve fuel economy

through moderate throttle characteristics and by controlling the operation of the air conditioning system (heating/cooling).
When not in Eco drive mode, if the driving mode select switch is turned toward you, the “Eco” indicator comes on.

3 Sport mode

Assists acceleration response by controlling the transmission, engine and steering. Suitable for when precise handling is desirable, for example when driving on mountain roads.

When not in Sport mode, if the driving mode select switch is turned backward, the “Sport” indicator comes on.

- ▶ Vehicles with Adaptive Variable Suspension system

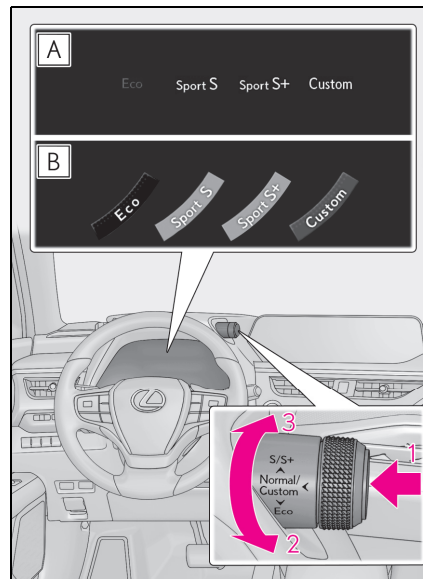

A Except F SPORT models

B F SPORT models

- 1** Normal mode/Custom mode
Normal mode and Custom mode are selected by pressing the driving mode

select switch. Each time the switch is pressed, the driving mode changes between Normal mode and Custom mode. When Custom mode is selected, the “Custom” indicator comes on.

Press the switch to change the driving mode to Normal mode when not in Normal mode.

- Normal mode

Provides an optimal balance of fuel economy, quietness, and dynamic performance.

Suitable for city driving.

- Custom mode

Allows you to drive with the power train, chassis and air conditioning system functions set to your preferred settings.

Custom mode settings can only be changed on the drive mode customization display of Center Display. (→P.351)

2 Eco drive mode

Helps the driver accelerate in an eco-friendly manner and improve fuel economy through moderate throttle characteristics and by controlling the operation of the air conditioning system (heating/cooling).

When not in Eco drive mode, if the driving mode select switch is turned toward you, the “Eco” indicator comes on.

3 Sport mode

- SPORT S mode

Assists acceleration response by controlling the transmission and engine.

When not in Sport S mode, if the driving mode select switch is turned away from you, the “Sport S” indicator comes on.

- SPORT S+ mode

Helps to ensure superior vehicle stability by simultaneously controlling the steering and suspension in addition to the transmission and engine. Suitable for sportier driving.

When in SPORT S mode, if the driving mode select switch is turned backward, the “Sport S+” indicator comes on.

■ Operation of the air conditioning system in Eco drive mode

Eco drive mode controls the heating/cooling operations and fan speed of the air conditioning system to enhance fuel efficiency. To improve air conditioning performance, perform the following operations:

- Turn off eco air conditioning mode (→P.360)
- Adjust the fan speed (→P.359)
- Turn off Eco drive mode

■ Automatic deactivation of Sport mode and Custom mode

If the engine switch is turned off after driving in Sport mode or Custom mode, the driving mode will be changed to Normal mode.

■ Driving mode pop-up display (vehicles with 10.3-inch display model)

When the driving mode is changed, the selected driving mode will be temporarily displayed on the side display. (→P.353)

For Custom mode, select “Setting” on the display to customize the driving mode.

■ Customization

The Custom mode can be changed. (Customizable features: →P.511)

Exhaust Gas Filter system*

*: If equipped

The Exhaust Gas Filter system is designed to collect particulate matter in the exhaust gases using an exhaust gas filter installed to the exhaust pipes.



NOTICE

- To prevent the Exhaust Gas Filter system from failing
- Do not use fuel other than the specified type
- Do not modify the exhaust pipes

Driving assist systems

To keep driving safety and performance, the following systems operate automatically in response to various driving situations. Be aware, however, that these systems are supplementary and should not be relied upon too heavily when operating the vehicle.

Summary of the driving assist systems

■ ABS (Anti-lock Brake System)

Helps to prevent wheel lock when the brakes are applied suddenly, or if the brakes are applied while driving on a slippery road surface

■ Brake assist

Generates an increased level of braking force after the brake pedal is depressed when the system detects a panic stop situation

■ VSC (Vehicle Stability Control)

Helps the driver to control skidding when swerving suddenly or turning on slippery road surfaces

■ VSC + (Vehicle Stability Control +)

Provides cooperative control of the ABS, TRC, VSC and EPS.
Helps to maintain directional stability when swerving on slippery road surfaces by controlling steering performance.

■ **Secondary Collision Brake (if equipped)**

When the airbag sensor detects a collision, the brakes and brake lights are automatically controlled to reduce the vehicle speed and that helps reduce the possibility of further damage due to a secondary collision.

■ **TRC (Traction Control)**

Helps to maintain drive power and prevent the drive wheels from spinning when starting the vehicle or accelerating on slippery roads

■ **Active Cornering Assist (ACA)**

Helps to prevent the vehicle from drifting to the outer side by performing inner wheel brake control when attempting to accelerate during cornering

■ **Hill-start assist control**

Helps to reduce the backward movement of the vehicle when starting on an uphill

■ **EPS (Electric Power Steering)**

Employs an electric motor to reduce the amount of effort needed to turn the steering wheel

■ **AVS (Adaptive Variable Suspension system) (if equipped)**

By independently controlling the damping force of the shock absorbers for each of the 4 wheels according to the road and driving conditions, this system helps riding comfort with superior vehicle stability, and helps good vehicle posture. If Sport S+ mode is

selected using the driving mode select switch, the damping force will become more suitable for sporty driving. (→P.337)

■ **Emergency brake signal**

When the brakes are applied suddenly, the stop lights automatically flash to alert the vehicle behind.

■ **When the TRC/VSC systems are operating**

The slip indicator light will flash while the TRC/VSC systems are operating.

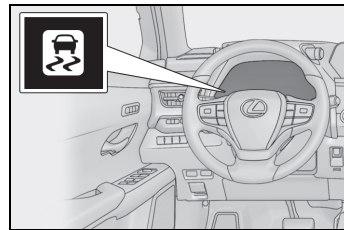

■ **Disabling the TRC system**

If the vehicle gets stuck in mud, dirt or snow, the TRC system may reduce power from the engine to the wheels. Pressing the > OFF switch to turn the system off may make it easier for you to rock the vehicle in order to free it.

To turn the TRC system off, quickly press and release the > OFF switch.

The "Traction Control Turned Off" will be shown on the multi-information display.

Press the > OFF switch again to turn the system back on.

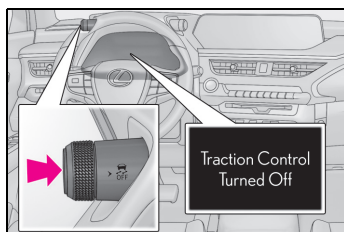

■ Turning off both TRC and VSC systems

To turn the TRC and VSC systems off, press and hold the  switch for more than 3 seconds while the vehicle is stopped.

The VSC OFF indicator light will come on and the “Traction Control Turned Off” will be shown on the multi-information display.*

Press the  switch again to turn the systems back on.

*: On vehicles with PCS (Pre-Collision System), PCS will also be disabled (only Pre-Collision warning is available). The PCS warning light will come on and a message will be displayed on the multi-information display. (→P.267)

■ When the message is displayed on the multi-information display showing that

TRC has been disabled even if the  switch has not been pressed

TRC is temporarily deactivated. If the information continues to show, contact any authorized Lexus retailer or Lexus authorized repairer, or any reliable repairer.

■ Operating conditions of hill-start assist control

When the following four conditions are met, the hill-start assist control will operate:

- The shift lever is in a position other than P or N (when starting off forward/backward on an upward incline)
- The vehicle is stopped
- The accelerator pedal is not depressed
- The parking brake is not engaged

■ Automatic system cancelation of hill-start assist control

The hill-start assist control will turn off in any of the following situations:

- The shift lever is shifted to P or N
- The accelerator pedal is depressed
- The parking brake is engaged
- 2 seconds at maximum elapsed after the brake pedal is released

■ Sounds and vibrations caused by the ABS, brake assist, VSC, TRC and hill-start assist control systems

- A sound may be heard from the engine compartment when the brake pedal is depressed repeatedly, when the engine is started or just after the vehicle begins to move. This sound does not indicate that a malfunction has occurred in any of these systems.
- Any of the following conditions may occur when the above systems are operating. None of these indicates that a malfunction has occurred.
 - Vibrations may be felt through the vehicle body and steering.
 - A motor sound may be heard also after the vehicle comes to a stop.
 - The brake pedal may pulsate slightly after the ABS is activated.
 - The brake pedal may move down slightly after the ABS is activated.

■ Active Cornering Assist operation sounds and vibrations

When Active Cornering Assist is operated, operation sounds and vibrations may be generated from the brake system, but this is not a malfunction.

■ EPS operation sound

When the steering wheel is operated, a motor sound (whirring sound) may be heard.

This does not indicate a malfunction.

■ Reduced effectiveness of the EPS system

The effectiveness of the EPS system is reduced to prevent the system from over-

heating when there is frequent steering input over an extended period of time. The steering wheel may feel heavy as a result. Should this occur, refrain from excessive steering input or stop the vehicle and turn the engine off. The EPS system should return to normal within 10 minutes.

■ **Automatic reactivation of TRC and VSC systems**

After turning the TRC and VSC systems off, the systems will be automatically re-enabled in the following situations:

- When the engine switch is turned off
- If only the TRC system is turned off, the TRC will turn on when vehicle speed increases. If both the TRC and VSC systems are turned off, automatic re-enabling will not occur when vehicle speed increases.

■ **Secondary Collision Brake operating conditions**

The vehicle speed is approximately 10 km/h (6 mph) or more and the airbag sensor detects a collision. (The Secondary Collision Brake will not operate when the vehicle speed is below approximately 10 km/h [6 mph].)

■ **Secondary Collision Brake automatic cancellation**

The Secondary Collision Brake is automatically canceled in the following situations:

- The vehicle speed drops below approximately 10 km/h (6 mph)
- A certain amount of time elapses during operation
- The accelerator pedal is depressed a large amount

■ **Operating conditions of emergency brake signal**

When the following three conditions are met, the emergency brake signal will operate:

- The emergency flashers are off
- Actual vehicle speed is over 55 km/h (35 mph)
- The brake pedal is depressed in a manner

that cause the system to judge from the vehicle deceleration that this is a sudden braking operation

■ **Automatic system cancelation of emergency brake signal**

The emergency brake signal will turn off in any of the following situations:

- The emergency flashers are turned on
- The brake pedal is released
- The system judges from the vehicle deceleration that is not a sudden braking operation

■ **Operating conditions of Active Cornering Assist**

The system operates in the following situations.

- TRC/VSC can operate
- The system determines that the vehicle is drifting to the outer side when attempting to accelerate during cornering
- The brake pedal is released

 **WARNING**

■ **The ABS does not operate effectively when**

- The limits of tire gripping performance have been exceeded (such as excessively worn tires on a snow covered road).
- The vehicle hydroplanes while driving at high speed on wet or slick roads.

■ **Stopping distance when the ABS is operating may exceed that of normal conditions**

The ABS is not designed to shorten the vehicle's stopping distance. Always maintain a safe distance from the vehicle in front of you, especially in the following situations:

- When driving on dirt, gravel or snow-covered roads
- When driving with tire chains

⚠ WARNING

- When driving over bumps in the road
- When driving over roads with potholes or uneven surfaces

■ TRC/VSC may not operate effectively when

Directional control and power may not be achievable while driving on slippery road surfaces, even if the TRC/VSC system is operating.

Drive the vehicle carefully in conditions where stability and power may be lost.

■ Active Cornering Assist does not operate effectively when

- Do not rely solely upon Active Cornering Assist. Active Cornering Assist may not operate effectively when accelerating down slopes or driving on slippery road surfaces.
- When Active Cornering Assist frequently operates, Active Cornering Assist may temporarily stop operating to ensure proper operation of the brakes, TRC, VSC.

■ Hill-start assist control does not operate effectively when

- Do not overly rely on hill-start assist control. Hill-start assist control may not operate effectively on steep inclines and roads covered with ice.
- Unlike the parking brake, hill-start assist control is not intended to hold the vehicle stationary for an extended period of time. Do not attempt to use hill-start assist control to hold the vehicle on an incline, as doing so may lead to an accident.

■ When the TRC/VSC is activated

The slip indicator light flashes. Always drive carefully. Reckless driving may cause an accident. Exercise particular care when the indicator light flashes.

■ When the TRC/VSC systems are turned off

Be especially careful and drive at a speed appropriate to the road conditions. As these are the systems to help ensure vehicle stability and driving force, do not turn the TRC/VSC systems off unless necessary.

■ Secondary Collision Brake

Do not overly rely on the Secondary Collision Brake. This system is designed to help reduce the possibility of further damage due to a secondary collision, however, that effect changes according to various conditions. Overly relying on the system may result in death or serious injury.

■ Replacing tires

Make sure that all tires are of the specified size, brand, tread pattern and total load capacity. In addition, make sure that the tires are inflated to the recommended tire inflation pressure level. The ABS, TRC and VSC systems will not function correctly if different tires are installed on the vehicle.

Contact any authorized Lexus retailer or Lexus authorized repairer, or any reliable repairer for further information when replacing tires or wheels.

■ Handling of tires and the suspension

Using tires with any kind of problem or modifying the suspension will affect the driving assist systems, and may cause a system to malfunction.

Winter driving tips

Carry out the necessary preparations and inspections before driving the vehicle in winter. Always drive the vehicle in a manner appropriate to the prevailing weather conditions.

Preparation for winter

- Use fluids that are appropriate to the prevailing outside temperatures.
 - Engine oil
 - Engine coolant
 - Washer fluid
- Have a service technician inspect the condition of the battery.
- Vehicles without run-flat tires: Have the vehicle fitted with four snow tires or purchase a set of tire chains for the front tires.

Ensure that all tires are the same size and brand, and that chains match the size of the tires.

- Vehicles with run-flat tires: It is recommended that the vehicle is fitted with four snow run-flat tires or purchase a set of tire chains for the front tires.

Ensure that all tires are the same size and brand, and that chains match the size of the tires.

WARNING

■ Driving with snow tires

Observe the following precautions to reduce the risk of accidents. Failure to do so may result in a loss of vehicle control and cause death or serious injury.

- Use tires of the specified size.
- Maintain the recommended level of air pressure.
- Do not drive at speeds in excess of the speed limit or the speed limit specified for the snow tires being used.
- Use snow tires on all, not just some wheels.

■ Driving with tire chains

Observe the following precautions to reduce the risk of accidents. Failure to do so may result in the vehicle being unable to be driven safely, and may cause death or serious injury.

- Do not drive in excess of the speed limit specified for the tire chains being used, or 50 km/h (30 mph), whichever is lower.
- Avoid driving on bumpy road surfaces or over potholes.
- Avoid sudden acceleration, abrupt steering, sudden braking and shifting operations that cause sudden engine braking.
- Slow down sufficiently before entering a curve to ensure that vehicle control is maintained.
- Do not use LTA (Lane Tracing Assist) (if equipped).

**NOTICE****■ Repairing or replacing snow tires**

Request repairs or replacement of snow tires from any authorized Lexus retailer or Lexus authorized repairer, or any reliable repairer or legitimate tire retailers. This is because the removal and attachment of snow tires affects the operation of the tire pressure warning valves and transmitters.

Before driving the vehicle

Perform the following according to the driving conditions:

- Do not try to forcibly open a window or move a wiper that is frozen. Pour warm water over the frozen area to melt the ice. Wipe away the water immediately to prevent it from freezing.
- To ensure proper operation of the climate control system fan, remove any snow that has accumulated on the air inlet vents in front of the windshield.
- Check for and remove any excess ice or snow that may have accumulated on the exterior lights, vehicle's roof, chassis, around the tires or on the brakes.
- Remove any snow or mud from the bottom of your shoes before getting in the vehicle.

When driving the vehicle

Accelerate the vehicle slowly, keep a safe distance between you and the

vehicle ahead, and drive at a reduced speed suitable to road conditions.

When parking the vehicle

- Park the vehicle and shift the shift lever to P without setting the parking brake. The parking brake may freeze up, preventing it from being released. If the vehicle is parked without setting the parking brake, make sure to block the wheels. Failure to do so may be dangerous because it may cause the vehicle to move unexpectedly, possibly leading to an accident.

When the parking brake is in automatic mode, release the parking brake after shifting the shift lever to P. (→P.225)

- If the vehicle is left parked with the brakes damp in cold temperatures, there is a possibility of the brakes freezing.
- If the vehicle is parked without setting the parking brake, confirm that the shift lever cannot be moved out of P*.

*: The shift lever will be locked if it is attempted to be shifted from P to any other position without depressing the brake pedal. If the shift lever can be shifted from P, there may be a problem with the shift lock system. Have the vehicle inspected by any authorized Lexus retailer or Lexus authorized repairer, or any reliable repairer.

⚠ WARNING

■ **When parking the vehicle**

When parking the vehicle without applying the parking brake, make sure to chock the wheels. If you do not chock the wheels, the vehicle may move unexpectedly, possibly resulting in an accident.

Selecting tire chains

Use the correct tire chain size when mounting the tire chains. Chain size is regulated for each tire size.

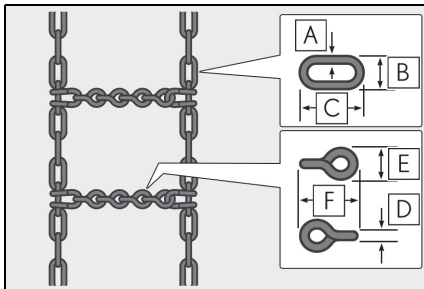

Side chain:

- A** 3 mm (0.12 in.) in diameter
- B** 10 mm (0.39 in.) in width
- C** 25 mm (0.98 in.) in length

Cross chain:

- D** 4 mm (0.16 in.) in diameter
- E** 14 mm (0.55 in.) in width
- F** 25 mm (0.98 in.) in length

Regulations on the use of tire chains

Regulations regarding the use of tire chains vary depending on location and type of road. Always check local regu-

lations before installing chains.

■ **Tire chain installation**

Observe the following precautions when installing and removing chains:

- Install and remove tire chains in a safe location.
- Install tire chains on the front tires only. Do not install tire chains on the rear tires.
- Install tire chains on front tires as tightly as possible. Retighten chains after driving 0.5 - 1.0 km (1/4 - 1/2 mile).
- Install tire chains following the instructions provided with the tire chains.

⚠ NOTICE

■ **Fitting tire chains**

The tire pressure warning valves and transmitters may not function correctly when tire chains are fitted.

Windshield wipers

To enable the windshield wipers to be lifted when heavy snow or icy conditions are expected, change the rest position of the windshield wipers from the retracted position below the hood to the service position using the wiper lever. (→P.243)

Utility vehicle precautions

This vehicle belongs to the utility vehicle class, which has higher ground clearance and narrower tread in relation to the height of its center of gravity.

Utility vehicle feature

- Specific design characteristics give it a higher center of gravity than ordinary passenger cars. This vehicle design feature causes this type of vehicle to be more likely to roll-over. Utility vehicles have a significantly higher rollover rate than other types of vehicles.
- An advantage of the higher ground clearance is a better view of the road allowing you to anticipate problems.
- It is not designed for cornering at the same speeds as ordinary passenger cars any more than low-slung sports cars designed to perform satisfactorily under off-road conditions. Therefore, sharp turns at excessive speeds may cause roll-over.

⚠ WARNING**Utility vehicle precautions**

Always observe the following precautions to minimize the risk of death or serious injury or damage to your vehicle:

- In a rollover crash, an unbelted person is significantly more likely to die than a person wearing a seat belt. Therefore, the driver and all passengers should always fasten their seat belts.
- Avoid sharp turns or abrupt maneuvers, if at all possible. Failure to operate this vehicle correctly may result in loss of control or vehicle rollover causing death or serious injury.
- Loading cargo on the roof luggage carrier (if equipped) will make the center of the vehicle gravity higher. Avoid high speeds, sudden starts, sharp turns, sudden braking or abrupt maneuvers, otherwise it may result in loss of control or vehicle rollover due to failure to operate this vehicle correctly.
- Always slow down in gusty crosswinds. Because of its profile and higher center of gravity, your vehicle is more sensitive to side winds than an ordinary passenger car. Slowing down will allow you to have better control.
- Do not drive horizontally across steep slopes. Driving straight up or straight down is preferred. Your vehicle (or any similar off-road vehicle) can tip over sideways much more easily than forward or backward.

Off-road driving

When driving your vehicle off-road, please observe the following precautions to ensure your driving enjoyment and to help prevent the closure of areas to off-road vehicles.

- Drive your vehicle only in areas where off-road vehicles are permitted to travel.
- Respect private property. Get owner's permission before entering private property.
- Do not enter areas that are closed. Honor gates, barriers and signs that restrict travel.
- Stay on established roads. When conditions are wet, driving techniques should be changed or travel delayed to prevent damage to roads.



WARNING

■ **Off-road driving precautions**

Always observe the following precautions to minimize the risk of death or serious injury or damage to your vehicle:

- Drive carefully when off the road. Do not take unnecessary risks by driving in dangerous places.
- Do not grip the steering wheel spokes when driving off-road. A bad bump could jerk the wheel and injure your hands. Keep both hands and especially your thumbs on the outside of the rim.
- Always check your brakes for effectiveness immediately after driving in sand, mud, water or snow.
- After driving through tall grass, mud, rock, sand, water, etc., check that there is no grass, bush, paper, rags, stone, sand, etc. adhering or trapped to the underbody. Clear off any such matter from the underbody. If the vehicle is used with these materials trapped or adhering to the underbody, a breakdown or fire could occur.

- When driving off-road or in rugged terrain, do not drive at excessive speeds, jump, make sharp turns, strike objects, etc. This may cause loss of control or vehicle rollover causing death or serious injury. You are also risking expensive damage to your vehicle's suspension and chassis.



NOTICE

■ **To prevent water damage**

Take all necessary safety measures to ensure that water damage to the engine or other components does not occur.

- Water entering the engine air intake will cause severe engine damage.
- Water entering the transmission will cause deterioration in shift quality, locking up of your transmission accompanied by vibration, and ultimately damage.
- Water can wash the grease from wheel bearings, causing rusting and premature failure, and may also enter the differentials and transmission reducing the gear oil's lubricating qualities.

■ **When you drive through water**

If driving through water, such as when crossing shallow streams, first check the depth of the water and the bottom of the riverbed for firmness. Drive slowly and avoid deep water.

■ **Inspection after off-road driving**

- Sand and mud that has accumulated around brake discs may affect braking efficiency and may damage brake system components.
- Always perform a maintenance inspection after each day of off-road driving that has taken you through rough terrain, sand, mud, or water.

- 5-1. Remote Touch
 - Remote Touch.....350
- 5-2. Lexus Climate Concierge
 - Lexus Climate Concierge.....354
- 5-3. Using the air conditioning system and defogger
 - Automatic air conditioning system356
 - Heated steering wheel/seat heaters/seat ventilators.....365
- 5-4. Using the interior lights
 - Interior lights list.....369
- 5-5. Using the storage features
 - List of storage features372
 - Luggage compartment features375
- 5-6. Using the other interior features
 - Other interior features380

Remote Touch

The Remote Touch can be used to operate Center Display. Owners of models equipped with a navigation system should refer to the “NAVIGATION AND MULTIMEDIA SYSTEM OWNER’S MANUAL”.

Remote Touch operation

■ Switches

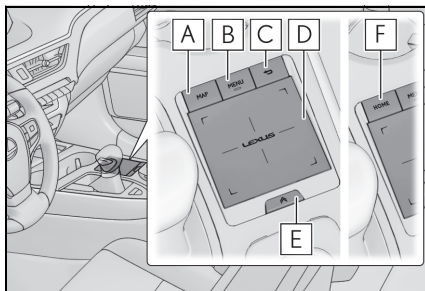

A “MAP” button (10.3-inch display model)

Press this button to display the vehicle’s current position.

B “MENU” button

Press this button to display the menu screen.

C Back button

Press this button to display the previous screen.

D Touchpad

Slide your finger on the touchpad and move the pointer to select a function, letter and screen button.

Press the touchpad to enter the selected function, letter or screen button. Certain finger movements on the touchpad can

perform functions, such as changing map scalings and scrolling list screens.

E Sub function button

When  is displayed on the screen, a function screen assigned to the screen can be displayed.

F “HOME” button (7-inch display model)

Press this button to display the menu screen.

■ Using the touchpad

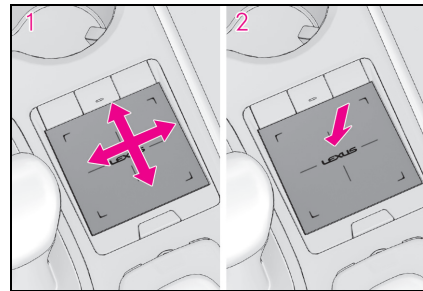

1 Select: Touch the touchpad to select the desired button on the screen.

2 Enter: The buttons on the screen can be selected by either depressing or double tapping on the touchpad. Once a button has been selected, the screen will change.

■ Touch operation

Operations are performed by touching the touchpad with your finger.

● Trace

Trace the pad surface while maintaining contact with the touch pad. Moving the cursor and the pointer.

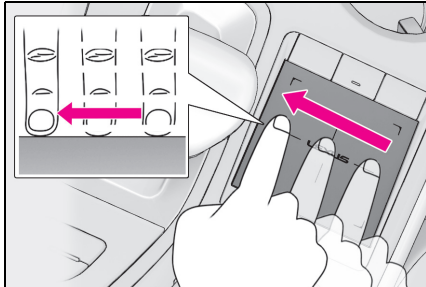

- Double tap

Tap the touchpad twice, quickly. Select the button on the screen.

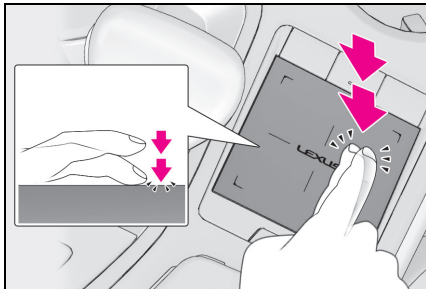

- Flick

Quick and long movement along the touchpad with your finger. Move the list screen.

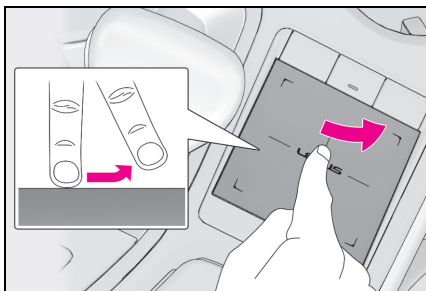

- Pinch in/Pinch out

Slide fingers toward each other or apart on the touchpad. Change the scale of the map.

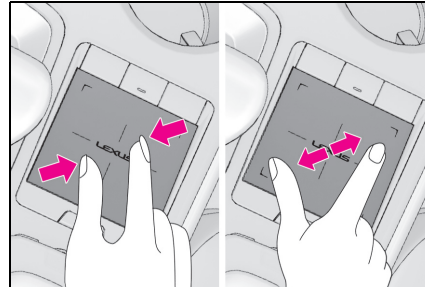

 NOTICE

■ To prevent damage to the Remote Touch

Observe the following precautions. Failure to do so may cause damage to the Remote Touch.

- Do not allow the Remote Touch to come into contact with food, liquid, stickers or lit cigarettes.
- Do not subject the Remote Touch to excessive pressure or strong impact.
- Do not push the touchpad with a strong force or use a sharp pointed object to operate the pad.

Center Display overview

■ Menu screen

Press the "MENU" button on the Remote Touch to display the menu screen.



The display may differ depending on the type of the system.







▶ 10.3-inch display model



▶ 7-inch display model



Switch	Function
	Select to display the "Destination" screen. *1
	Select to display the radio control screen. *1

Switch	Function
	Select to display the media control screen. *1
	Select to display the hands-free control screen. *1
	Select to display the "Apps" screen. *1,2
	Select to display the information screen. *1
	Select to display the "Setup" screen.
	Select to display the air conditioning control screen. (→P.359)
	Select to adjust the contrast and brightness of the screens, turn the screen off, etc. *1,2

*1: Refer to the "NAVIGATION AND MULTIMEDIA SYSTEM OWNER'S MANUAL".

*2: This function is not made available on some models.

■ Split-screen display (10.3-inch display model)

Different information can be displayed on the left and right of the screen. For example, the air conditioning system screen can be displayed and operated while the fuel consumption information screen is being displayed. The large screen on the left of the display is called the main display, and the small screen to the right is called the side display.

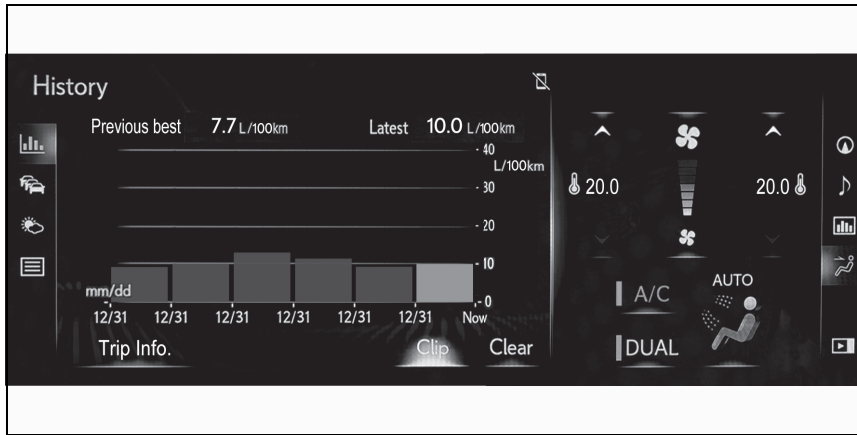

■ Main display

For details about the functions and operation of the main display, refer to the respective section and "NAVIGATION AND MULTIMEDIA SYSTEM OWNER'S MANUAL".

■ Side display (10.3-inch display model)

The following functions can be displayed and operated on the side display.

Select **<** or **>** to display the desired screen.

C Vehicle information

D Air conditioning system (→P.359)

E Show/hide the side display.

* : Refer to the "NAVIGATION AND MULTIMEDIA SYSTEM OWNER'S MANUAL".

■ Screen display during low temperatures

When the ambient temperature is extremely low, screen response may be delayed even if the Remote Touch is operated.

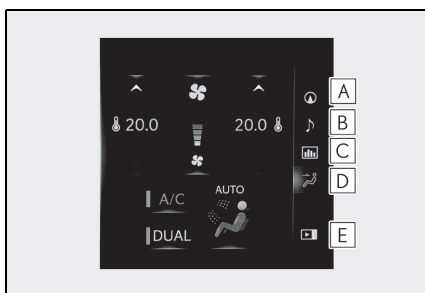

A Navigation system *

B Audio *

Lexus Climate Concierge

The seat heaters (if equipped), seat ventilators (if equipped) and heated steering wheel (if equipped) are each automatically controlled according to the set temperature of the air conditioning system, the outside and cabin temperature, etc. Lexus Climate Concierge allows a comfortable condition to be maintained without adjusting each system.

Press the “MENU” button on the Remote Touch and select “Climate” to display the air conditioning control screen. Then, select  to display the Lexus Climate Concierge control screen.

Turning on Lexus Climate Concierge

Select 

The indicator on the Lexus Climate Concierge control screen illuminates, and the automatic air conditioning system, seat heaters and ventilators (if equipped), and heated steering wheel (if equipped) operate in automatic mode.

If any of the system is operated manually, the indicator turns off. However, all other functions continue to operate in automatic mode.



■ When using the Lexus Climate Concierge

Lexus Climate Concierge can be operated on the sub function menu or option control screen. (→P.359)

Operation of each system

■ Automatic air conditioning system (→P.356)

The temperature can be adjusted independently for the driver seat and passenger seat.

■ Seat heaters and ventilators (if equipped) (→P.365)

Heating or ventilation is automatically selected according to the set temperature of the air conditioning system, the outside temperature, etc.

The seat heater and ventilator of the front passenger seat operate in automatic mode if a passenger is detected.

■ Heated steering wheel (if equipped) (→P.365)

Heated steering wheel operates automatically according to the set temperature of the air conditioning system, the outside temperature, etc.

■ **Seat heater/ventilator operation**

When automatic mode is selected using the seat heater/ventilator switch, passenger detection is not performed.

Automatic air conditioning system

Air outlets and fan speed are automatically adjusted according to the temperature setting.

Press the "MENU" button on the Remote Touch, then select "Climate" to display the air conditioning control screen. (→P.359)

10.3-inch display model: The air conditioning system can be displayed and operated on the side display.

The illustrations below are for left-hand drive vehicles.

The button positions will differ for right-hand drive vehicles.

Air conditioning controls

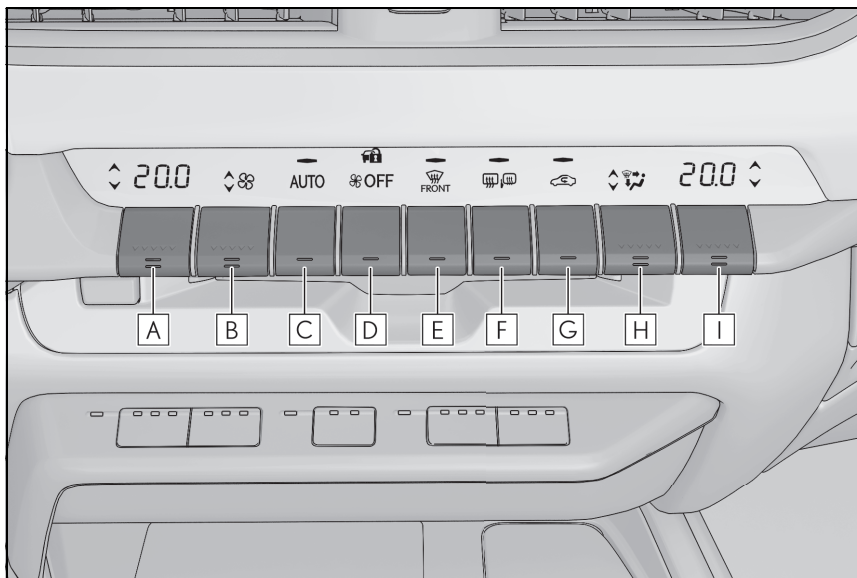

- A** Left-hand side temperature control switch
- B** Fan speed control switch
- C** Automatic mode switch
- D** Off switch
- E** Windshield defogger switch
- F** Rear window and outside rear view mirror defoggers switch

G Outside/recirculated air mode switch

H Airflow mode control switch

I Right-hand side temperature control switch

■ Adjusting the temperature

Operate the temperature control switch upwards to increase the temperature and downwards to decrease the temperature.

■ Setting the fan speed

Operate the fan speed control switch upwards to increase the fan speed and downwards to decrease the fan speed.

Press the off switch to turn the fan off.

■ Change the airflow mode

Operate the airflow mode control switch upwards or downwards.

The mode changes as follows each time the switch is operated.

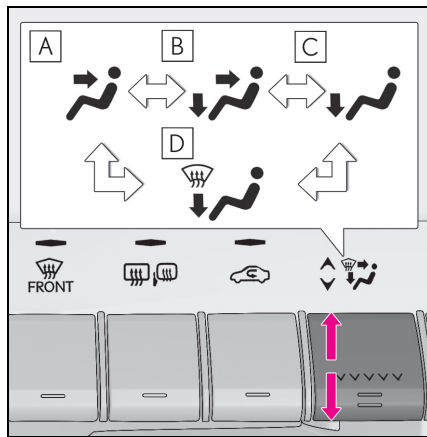

A Air flows to the upper body.

B Air flows to the upper body and feet.

C Air flows to the feet.

D Air flows to the feet and the windshield defogger operates.

■ Switching between outside air and recirculated air modes

Press the outside/recirculated air mode switch.

The mode switches between outside air mode (the indicator is off) and recirculated air mode (the indicator is on) each time the switch is pressed.

■ Defogging the windshield

Defoggers are used to defog the windshield and front side windows.

Press the windshield defogger switch.

Set the outside/recirculated air mode switch to outside air mode if the recirculated air mode is used. (It may switch automatically.)

To defog the windshield and the side windows early, turn the air flow and temperature up.

To return to the previous mode, press the windshield defogger switch again when the windshield is defogged.

■ Defogging the rear window and outside rear view mirrors

Defoggers are used to defog the rear window and to remove raindrops, dew and frost from the outside rear view mirrors.

Press the rear window and outside rear view mirror defoggers switch.

The defoggers will automatically turn off

after a period of time.

■ **Windshield wiper de-icer (if equipped)**

→P.361

■ **Fogging up of the windows**

- The windows will easily fog up when the humidity in the vehicle is high. Pressing "A/C" button or selecting "A/C" will dehumidify the air from the outlets and defog the windshield effectively.
- If you turn "A/C" off, the windows may fog up more easily.
- The windows may fog up if the recirculated air mode is used.

■ **Outside/recirculated air mode**

- When driving on dusty roads such as tunnels or in heavy traffic, set the outside/recirculated air mode switch to the recirculated air mode. This is effective in preventing outside air from entering the vehicle interior. During cooling operation, setting the recirculated air mode will also cool the vehicle interior effectively.
- Outside/recirculated air mode may automatically switch depending on the temperature setting or the inside temperature.

■ **Registering air conditioning settings to electronic keys (vehicles with driving position memory)**

- Unlocking the vehicle using an electronic key and turning the engine switch to ON will recall that key's registered air conditioning settings.
- When the engine switch is turned off, the current air conditioning settings will automatically be registered to the electronic key that was used to unlock the vehicle.
- The system may not operate correctly if more than one electronic key is in the vicinity or if the smart entry & start system is used to unlock a passenger door.
- The doors that can recall the air conditioning setting when unlocked using the smart entry & start system can be

changed.* For details, contact any authorized Lexus retailer or Lexus authorized repairer, or any reliable repairer.

* : The doors that can recall the driving position memory are changed at the same time.

■ **Operation of the air conditioning system in Eco drive mode**

- In Eco drive mode, the air conditioning system is controlled as follows to prioritize fuel efficiency
 - Engine speed and compressor operation controlled to restrict heating/cooling capacity
 - Fan speed restricted when automatic mode is selected
- To improve air conditioning performance, perform the following operations
 - Turn off eco air conditioning mode (→P.361)
 - Adjust the fan speed
 - Turn off Eco drive mode

■ **Air conditioning system operation while the engine is stopped by the Stop & Start system (if equipped)**

→P.297

■ **Changing the idling stop time with the air conditioning system on (if equipped)**

→P.297

■ **When the outside temperature is low**

The dehumidification function may not operate even when "A/C" is pressed or "A/C" is selected.

■ **Ventilation and air conditioning odors**

- To let fresh air in, set the air conditioning system to the outside air mode.
- During use, various odors from inside and outside the vehicle may enter into and accumulate in the air conditioning system. This may then cause odor to be emitted from the vents.
- To reduce potential odors from occurring:
 - It is recommended that the air conditioning system be set to outside air mode prior to turning the vehicle off.

- The start timing of the blower may be delayed for a short period of time immediately after the air conditioning system is started in automatic mode.

■ **Air conditioning filter**

→P.426

■ **Customization**

Settings (e.g. A/C automatic mode switch operation) can be changed.
(Customizable features: →P.512)

⚠ WARNING

■ **To prevent the windshield from fogging up**

Do not use the windshield defogger switch during cool air operation in extremely humid weather. The difference between the temperature of the outside air and that of the windshield can cause the outer surface of the windshield to fog up, blocking your vision.

■ **When the outside rear view mirror defoggers are operating**

Do not touch the outside rear view mirror surfaces, as they can become very hot and burn you.

⚠ NOTICE

■ **To prevent battery discharge**

Do not leave the air conditioning system on longer than necessary when the engine is off.

Air conditioning control screen

■ **Main control screen**

Using the touchpad of the Remote Touch, select the button on the screen.

B to **E** can be adjusted by performing the following operations.

Flick operation: Move the pointer to

the desired item and flick the touchpad up or down.

The item can be adjusted by one level.

Trace operation: After selecting the desired item, slide your finger up or down.

The item can be adjusted by the amount that you trace.

Trace operation cannot be used while driving.

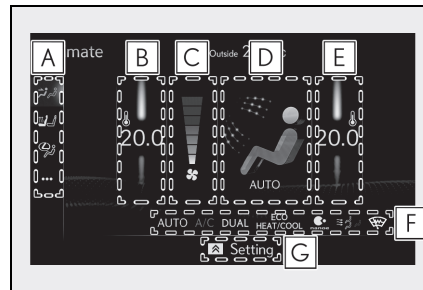

A Sub menu

Selecting the sub menu item to switch the main screen.

: Display the air conditioning control screen

: Display the heated steering wheel/seat heater/seat ventilator control screen (if equipped)

: Display the Lexus Climate Concierge control screen

: Display the option control screen

B Adjust the left-hand side temperature setting

C Adjust the fan speed setting

D Select the air flow mode



: Air flows to the upper body



: Air flows to the upper body and feet



: Air flows to the feet



: Air flows to the feet and the windshield defogger operates

E Adjust the right-hand side temperature setting

F Function on/off indicators

When the function is on, the indicator illuminates on the control screen.

G Sub function menu

When the sub function button on the Remote Touch is pressed, the following functions can be switched on and off.



: Set Lexus Climate Concierge (→P.354)

"AUTO": Set automatic mode on/off (→P.362)

"OFF": Turn the fan off

"A/C": Set cooling and dehumidification function

"DUAL": Adjust the temperature for driver and front passenger seats separately ("DUAL" mode) (→P.363)



: Changing the fan speed setting during the automatic mode operation (Blower customization)



: Set eco air conditioning mode

■ Option control screen

Select  on the sub menu to display the option control screen.

The functions can be switched on and off.

When the function is on, the indicator illuminates on the screen.

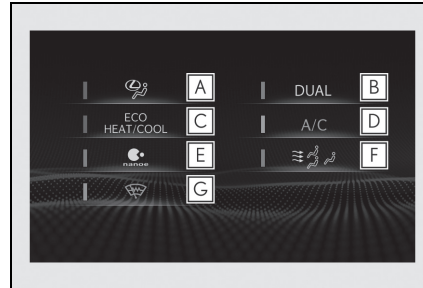

A Set Lexus Climate Concierge (→P.354)

B Adjusting the temperature for driver and front passenger seats separately ("DUAL" mode) (→P.363)

C Set eco air conditioning mode
Air conditioning and heater output is limited to prioritize fuel economy.

D Cooling and dehumidification function

E nanoe™* system on/off

F Select S-FLOW mode (→P.363)

G Prevent ice from building up on the windshield and wiper blades (Windshield wiper de-icer) (if equipped)

*: nanoe™ and the nanoe™ mark are trademarks of Panasonic Corporation.

■ Side display (10.3-inch display model)

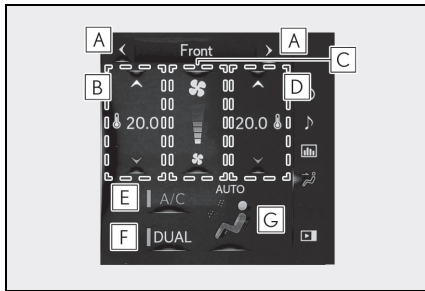

- A** Display the heated steering wheel/seat heaters/seat ventilators control screen (if equipped) (→P.365)
- B** Adjust the left-hand side temperature setting
- C** Adjust the fan speed setting
- D** Adjust the right-hand side temperature setting
- E** Set cooling and dehumidification function on/off
- F** Adjust the temperature for the driver's and front passenger's seats separately ("DUAL" mode) (→P.363)
- G** Select the air flow mode

■ Windshield wiper de-icer (if equipped)

This feature is used to prevent ice from building up on the windshield and wiper blades.

The windshield wiper de-icer will automatically turn off after a period of time.

■ Eco air conditioning mode

When Eco drive mode is selected using the driving mode select switch, eco air condi-

tioning mode turns on.

When a driving mode other than Eco drive mode is selected, eco air conditioning mode may turn off.



■ nanoe™ system

This vehicle incorporates a biocidal product.

Ionised air generated by a device incorporated in the vehicle purifies the air in the cabin by suppressing bacteria.

Active substance: Free radicals generated in situ from ambient air or water

nanoe™ helps to provide purified air by emitting electrically charged water particles through the side vent on the driver's side*.

- When the fan is turned on and nanoe™ on the option control screen is selected, the nanoe™ system is activated.
- When the fan is operated in the following conditions, system performance will be maximized. If the following conditions are not met, performance will be limited.
 - The , , or  air outlets are being used.
 - The side vent on driver's side is open.
- When nanoe™ is generated, a small amount of ozone is emitted and may be faintly smelled in some situations. However, this is approximately the same as the amount that already exists in nature, such as in forests, and it has no affect on the human body.
- A slight noise may be heard during operation. This is not a malfunction.

*: According to temperature and humidity conditions, fan speed and direction of the air flow, the nanoe™ system may not operate at full capacity.

■ Blower customization

Fan speed setting during the automatic mode operation can be customized.

To change the fan speed setting mode, select  on the air conditioning con-

trol screen.

Each time  is selected, the fan speed setting mode changes as follows.

“NORMAL” → “ECO” → “FAST” → “NORMAL”

⚠ WARNING

■ **To prevent burns (vehicles with windshield wiper de-icer)**
Do not touch the glass at lower part of the windshield or to the side of the front pillars when the windshield wiper de-icer is on.

■ **nanoe™ generator**
Do not disassemble or repair the generator because it contains high voltage parts. Contact any authorized Lexus retailer or Lexus authorized repairer, or any reliable repairer if the generator needs repair.

⚠ NOTICE

■ **To prevent damage to the nanoe™**
Do not insert anything into the driver’s side vent, attach anything to it, or use sprays around the driver’s side vent. These things may cause the generator not to work properly.

Using automatic mode

- 1 Press the automatic mode switch or select “AUTO” on the sub function menu. (→P.359)
- 2 Adjust the temperature setting.
- 3 To stop the operation, press the off switch or select “Off” on the sub function menu.

If the fan speed setting or air flow modes are operated, the automatic mode indicator goes off. However,

automatic mode for functions other than that operated is maintained.

■ **Using automatic mode**

Fan speed is adjusted automatically according to the temperature setting and the ambient conditions.

Therefore, the fan may stop for a while until warm or cool air is ready to flow immediately after the automatic mode switch is pressed or “AUTO” is selected.

Cool air may blow around the upper body even when the heater is on due to sunlight.

■ **Windshield fog detection function**

When automatic mode is set, the humidity sensor detects fog on the windshield and controls the air conditioning system to prevent fog.

⚠ NOTICE

■ **Humidity sensor**
In order to detect fog on the windshield, a sensor which monitors the temperature of the windshield, the surround humidity, etc., is installed. Follow these points to avoid damaging the sensor:

- Do not disassemble the sensor
- Do not spray the glass cleaner on the sensor or subject it to strong impacts
- Do not stick anything on the sensor

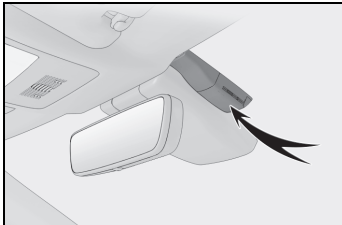

S-FLOW mode

In S-FLOW mode, priority for the airflow is given to the front seats, reducing the airflow and air conditioning effect on the rear seats.

The following S-FLOW modes are available:

▶ Automatic S-FLOW mode

When a rear passenger is determined to be in the vehicle, S-FLOW mode will be automatically disabled.

The indicator will illuminate on the air conditioning control screen when S-FLOW mode is enabled.

To enable/disable S-FLOW mode and enter manual S-FLOW mode, select the S-FLOW mode switch. (→P.360)

▶ Manual S-FLOW mode

When the S-FLOW mode switch is selected, S-FLOW mode will be manually enabled/ disabled.

The indicator will illuminate on the air conditioning control screen when S-FLOW mode is enabled.

The system does not determine whether a passenger is in the rear seats by the opening and closing of a rear door, so S-FLOW mode cannot be automatically disabled.

To automatically disable S-FLOW mode by opening and closing a rear door, switch to automatic S-FLOW mode.

■ S-FLOW air conditioning control

Operation of S-FLOW mode changes

according to the following conditions. However, depending on the set temperature and air conditioning load is high, the operation may not change.

● Front seat priority:

When the system determines there are no passengers in the rear seats

● S-FLOW disabled:

When the system determines there is a passenger in the rear seats

■ Passenger presence determination in S-FLOW mode

The system determines that there is a passenger when a rear door is opened and closed.

If a passenger is judged to be in the vehicle, the system will retain the judgment for a certain amount of time after the engine switch is turned off.

■ Operation of automatic S-FLOW mode

When the system is operating in S-FLOW mode, if a rear door is opened and then closed, S-FLOW mode will be disabled. To enable S-FLOW mode, select the S-FLOW mode switch. In this case, the system switches to manual S-FLOW mode.

■ Changing from manual S-FLOW mode to automatic S-FLOW mode

- 1 Select the S-FLOW mode switch to disable S-FLOW mode
- 2 Turn the engine switch off.
- 3 After 60 minutes have elapsed, change the engine switch to ON.

Adjusting the temperature for driver and front passenger seats separately ("DUAL" mode)

To turn on the "DUAL" mode, perform any of the following procedures:

- Select "DUAL" on the sub function

menu. (→P.359)

- Select "DUAL" on the option control screen.
- Adjust the front passenger's side temperature setting.

The indicator comes on when the "DUAL" mode is on.

Air outlet layout and operations

■ Location of air outlets

The air outlets and air volume changes according to the selected air flow mode.

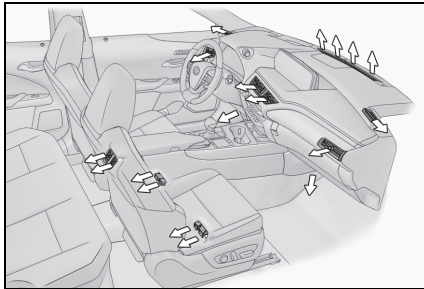

■ Adjusting the position of and opening and closing the air outlets

► Front

Direct air flow to the left or right, up or down

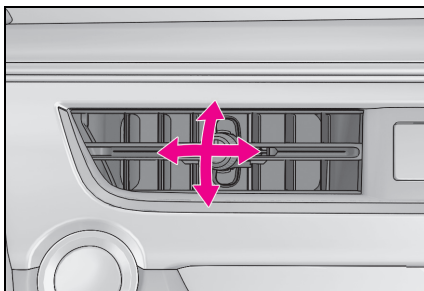

Turn the knob to open or close the vent

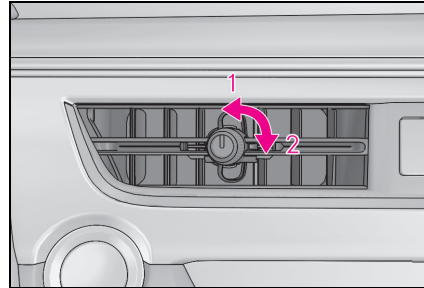

- 1 Open the outlet
- 2 Close the outlet

► Rear

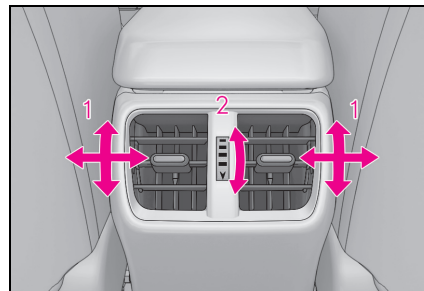

- 1 Direct air flow to the left or right, up or down
- 2 Turn the knob to open or close the vent

⚠ WARNING**■ To prevent the windshield defogger from operating improperly**

Do not place anything on the instrument panel which may cover the air outlets. Otherwise, air flow may be obstructed, preventing the windshield defoggers from defogging.

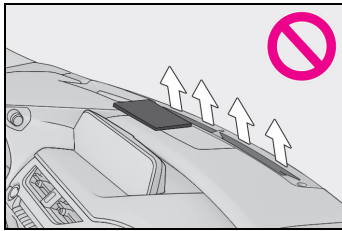
**Heated steering wheel* / seat heaters* / seat ventilators***

*: If equipped

● Heated steering wheel

Warms up the grip of the steering wheel

● Seat heaters

Warm up the seat upholstery

● Seat ventilators

Maintain good airflow on the seat upholstery by sucking air into the seats

Press the "MENU" button on the Remote Touch and select "Climate" to display the air conditioning control screen. Then, select  on the sub menu (→P.359) to display the heated steering wheel/seat heaters/seat ventilators control screen.

⚠ WARNING**■ To prevent minor burn injuries**

Care should be taken if anyone in the following categories comes in contact with the steering wheel or seats when the heater is on:

- Babies, small children, the elderly, the sick and the physically challenged
- Persons with sensitive skin
- Persons who are fatigued
- Persons who have taken alcohol or drugs that induce sleep (sleeping drugs, cold remedies, etc.)

**NOTICE**

■ **To prevent damage to the seat heaters and seat ventilators**

Do not put heavy objects that have an uneven surface on the seat and do not stick sharp objects (needles, nails, etc.) into the seat.

■ **To prevent battery discharge**

Do not use the functions when the engine is off.

Heated steering wheel

Turns the heated steering wheel on/off

Each time the switch is pressed, the operation condition changes as follows.

AUTO (lit) → Hi (2 segments lit) → Lo (1 segment lit) → Off

The AUTO indicator **A** and/or level indicator **B** illuminates during operation.

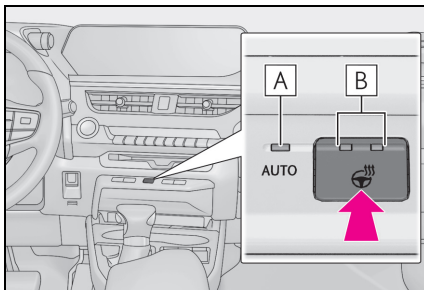

■ **The heated steering wheel can be used when**

The engine switch is in ON.

■ **Customization**

Steering wheel heating preference in automatic mode can be changed. (Customizable features: →P.512)

Seat heaters and ventilators (front seats)

■ **Seat heaters**

Turns the seat heaters on/off

Each time the switch is pressed, the operation condition changes as follows.

AUTO (lit) → Hi (3 segments lit) → Mid (2 segments lit) → Lo (1 segment lit) → Off

The AUTO indicator **A** and/or level indicator **B** illuminates during operation.

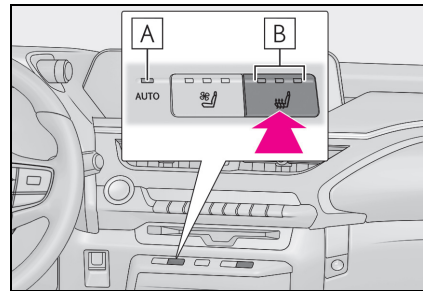

■ **Seat ventilators**

Turns the seat ventilators on/off

Each time the switch is pressed, the operation condition changes as follows.

AUTO (lit) → Hi (3 segments lit) → Mid (2 segments lit) → Lo (1 segment lit) → Off

The AUTO indicator **A** and/or level indicator **B** illuminates during operation.

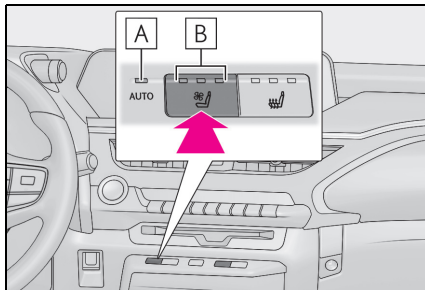

■ The seat ventilators can be used when

The engine switch is in ON.

■ Air conditioning system-linked control mode

When the seat ventilator fan speed level is Hi, the seat ventilator fan speed becomes higher according to the fan speed of the air conditioning system.

■ Customization

Settings for the seat heaters and ventilators can be changed. (Customizable features: →P.512)

⚠ WARNING

■ To prevent causes of overheating and minor burn injuries

Observe the following precautions when using the seat heaters.

- Do not cover the seat with a blanket or cushion when using the seat heater.
- Do not use seat heater more than necessary.

Control screen

■ Main display

Using the touchpad of the Remote Touch, select the button on the screen.

A to **C** can be adjusted by performing the following operations.

Flick operation: Move the pointer to

the desired item and flick the touchpad up or down.

The item can be adjusted by one level.

Trace operation: After selecting the desired item, trace the pad surface.

The item can be adjusted by the amount that you trace.

Trace operation cannot be used while driving.

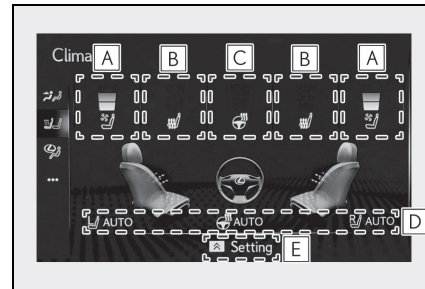

A Adjust the seat ventilator fan speed level

The seat ventilator can be adjusted in 3 levels.

When the seat ventilator is operated, the fan speed level is displayed on the screen.

B Adjust the seat heater temperature level

The seat heater can be adjusted in 3 levels. When the seat heater is operated, the temperature level is displayed on the screen.

C Adjust the heated steering wheel temperature level

The heated steering wheel can be adjusted in 2 levels.

When the heated steering wheel is operated, the temperature level is displayed on the screen.

D Automatic mode on/off indicators

When the automatic mode is on, the indicator illuminates on the screen.

E Sub function menu

When the sub function button on the Remote Touch is pressed, the following functions can be set to automatic mode.

 **AUTO**: Left-hand side seat heater/seat ventilator

 **AUTO**: Heated steering wheel

 **AUTO**: Right-hand side seat heater/seat ventilator

■ **Side display (10.3-inch display model)**

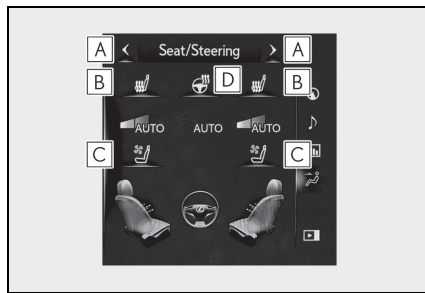

A Display the air conditioning control screen (→P.359)

B Adjust the seat heater temperature level

Each time the switch is selected, the temperature level and level indicator (orange) change as follows:

AUTO → Hi → Mid → Lo → Off

C Adjust the seat ventilator fan speed level

Each time the switch is selected, the fan speed level and level indicator (blue) change as follows:

AUTO → Hi → Mid → Lo → Off

D Adjust the heated steering wheel

temperature level

Each time the switch is selected, the temperature level and level indicator change as follows:

AUTO → Hi → Lo → Off

Interior lights list

Location of the interior lights

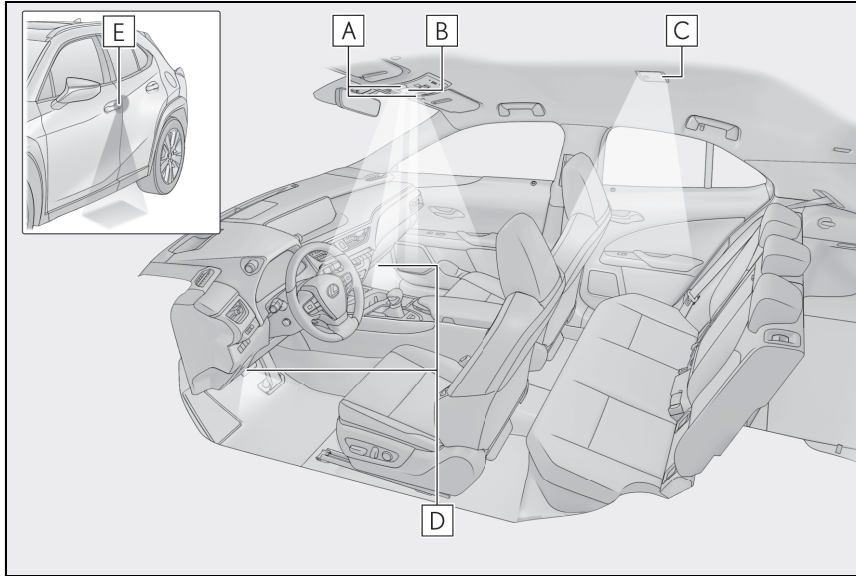

A Personal lights (→P.371)

B Front interior light (→P.370)

C Rear interior light (→P.370)

D Footwell lights

- When the engine switch is in ON, the footwell lights will turn on. However, if the instrument panel light control switch is turned to minimum, the footwell lights will turn off. (→P.110, 114)
- When the shift lever is in a position other than P, the brightness of the footwell light will reduce intensity.

E Outside door handle lights (vehicles with entry function)

■ Personal lights/interior lights automatic on/off

- Illuminated entry system: The lights automatically turn on/off according to engine switch mode, the presence of the electronic key, whether the doors are locked/unlocked, and whether the doors are opened/closed.

- If the interior lights remain on when the engine switch is turned off, the lights will go off automatically after 20 minutes.

■ When front interior light and personal lights do not respond as normal

- When water, dirt, etc., have adhered to the lens surface
- When operated with a wet hand

- When wearing gloves, etc.
- **Automatic turning on of the interior lights**

If any of the SRS airbags deploy (inflate) or in the event of a strong rear impact, the interior lights will turn on automatically. The interior lights will turn off automatically after approximately 20 minutes.

The interior lights can be turned off manually. However, in order to help prevent further collisions, it is recommended that they be left on until safety can be ensured.

(The interior lights may not turn on automatically depending on the force of the impact and conditions of the collision.)

■ **Customization**

Setting (e.g. the time elapsed before the lights turn off) can be changed. (Customizable features: →P.513)

 **NOTICE**

■ **Removing light lenses**
Never remove the lens for the front interior light and personal lights. Otherwise, the lights will be damaged. If the lens need to remove, contact any authorized Lexus retailer or Lexus authorized repairer, or any reliable repairer.

■ **To prevent battery discharge**
Do not leave the lights on longer than necessary when the engine is off.

Operating the interior lights

■ **Turning the door position on**

Press the door-linked interior light switch

The lights are turned on and off according to whether the doors are opened/closed.

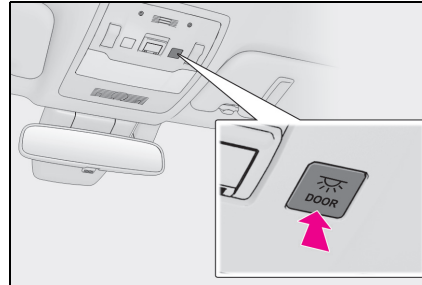

■ **Turning the lights on/off**

▶ **Front**

Turns the lights on/off (touch the light)

When a door is opened while the door position is on, the lights turn on.

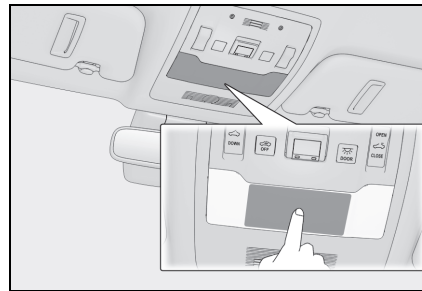

▶ **Rear**

On/off

The rear interior light turns on/off together with the front interior light.

When a door is opened while the door position is on, the lights turn on.

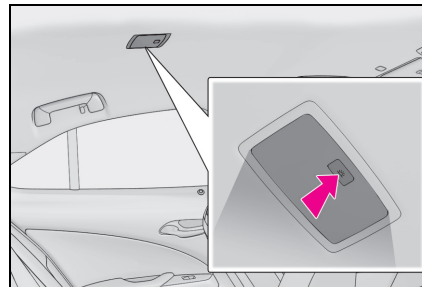

Operating the personal lights

■ Turning the lights on/off

Turns the lights on/off (touch the light)

When a door is opened while the door position is on, the lights turn on.

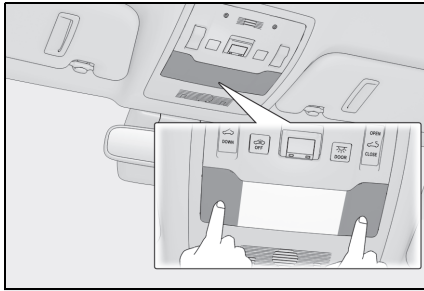

List of storage features

Location of the storage features

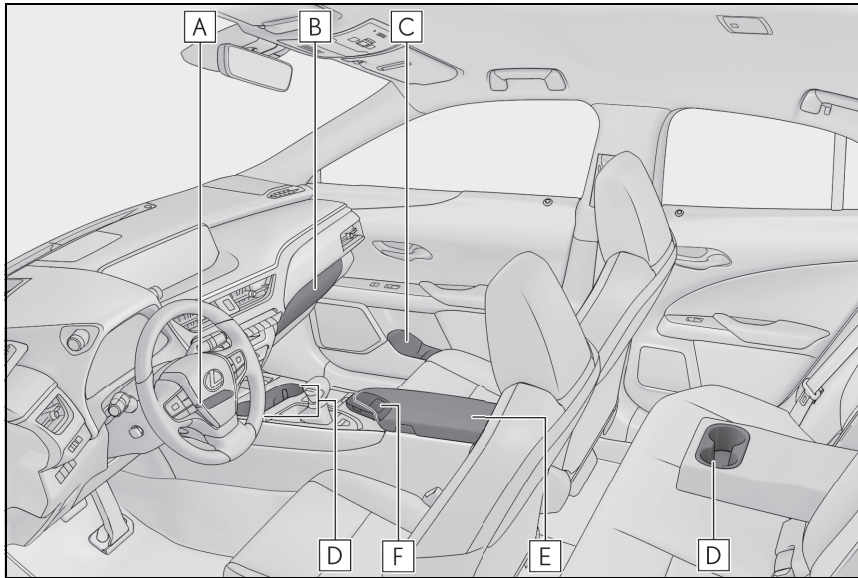

- A** Auxiliary tray/Wireless charger (if equipped) (→P.382)
- B** Glove box (→P.373)
- C** Bottle holders (→P.374)
- D** Cup holders (→P.373)
- E** Console box (→P.373)
- F** Coin holder (→P.374)

⚠ WARNING**■ Items that should not be left in the vehicle**

Do not leave glasses, lighters or spray cans in the storage spaces, as this may cause the following when cabin temperature becomes high:

- Glasses may be deformed by heat or cracked if they come into contact with other stored items.
- Lighters or spray cans may explode. If they come into contact with other stored items, the lighter may catch fire or the spray can may release gas, causing a fire hazard.

■ When storage compartments are not in use

When driving or when the glove box and the console box are not in use, keep it closed.

In the event of sudden braking or sudden swerving, an accident may occur due to an occupant being struck by an open lid or the items stored inside.

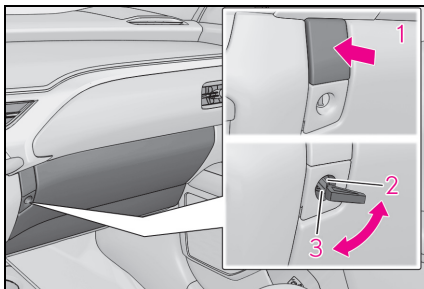
Glove box

- 1** Open (press the button)
- 2** Unlock with the mechanical key
- 3** Lock with the mechanical key

■ Glove box light

The glove box light turns on when the tail lights are on.

■ Removing the partition

The partition inside the glove box can be removed by pulling it.

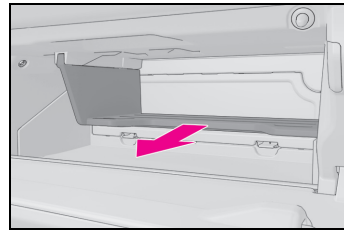
**Console box**

Lift the lid while pushing the button to release the lock.

The console box can be opened from either side.

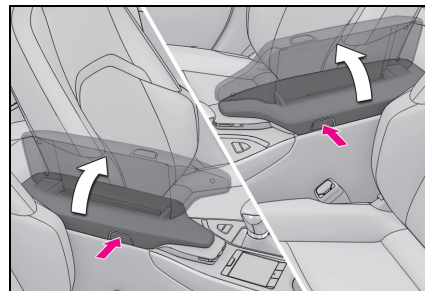
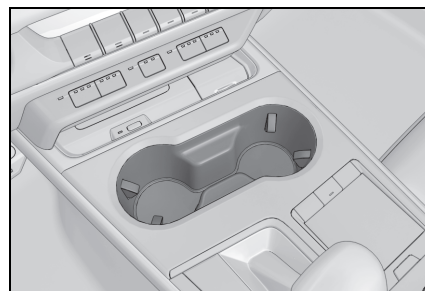
**Cup holders****■ Front**

■ Rear

Pull down the armrest.

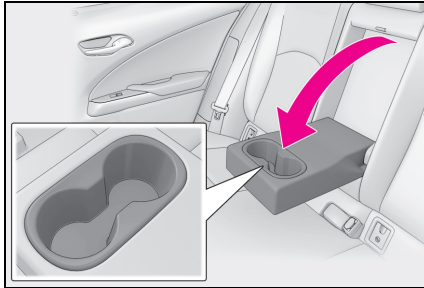

! WARNING

■ Items unsuitable for the cup holders

Do not place anything other than cups or aluminum cans in the cup holders. Other items may be thrown out of the holders in the event of an accident or sudden braking, causing injury. If possible, cover hot drinks to prevent burns.

Bottle holders

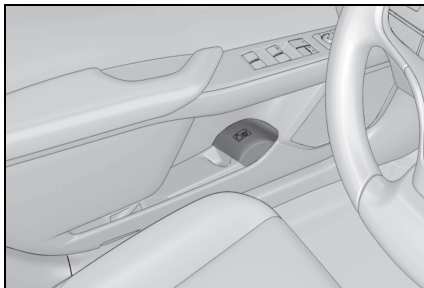

■ Bottle holders

- When storing a bottle, close the cap.
- The bottle may not be stored depending on its size or shape.

! NOTICE

■ Items that should be not stowed in the bottle holders

Do not place open bottles or glass and paper cups containing liquid in the bottle holders. The contents may spill and glasses may break.

Coin holder

Open the console box. (→P.373)

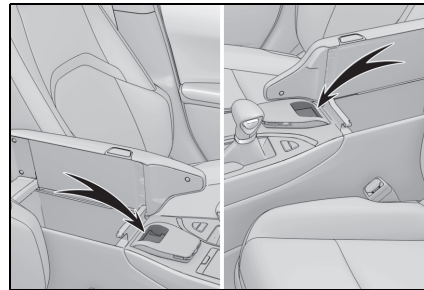

! NOTICE

■ Coin holder

Do not insert coins exceeding the height of the tray. Doing so may prevent opening and closing of the lid.

Luggage compartment features

Cargo hooks

Raise the hooks to use.

The cargo hooks are provided for securing loose items.

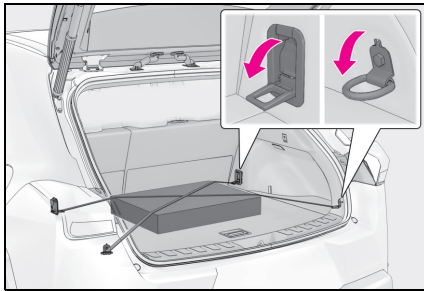

⚠ WARNING

■ When cargo hooks are not in use

To avoid injury, always return the hooks to their stowed positions when not in use.

Grocery bag hooks

When using the hooks, press the bottom side to lift it up.

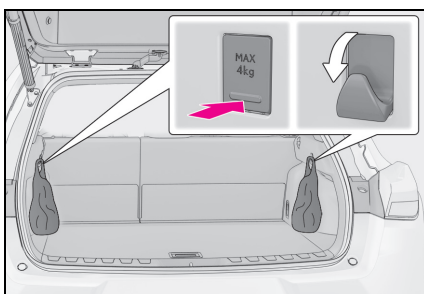

⚠ NOTICE

■ To prevent damage to the grocery bag hooks

Do not hang any object heavier than 4kg (9 lb.) on the grocery bag hooks.

Deck under tray

Lift the deck board and attach the string. (→P.376) The following items can be stowed.

▶ Vehicles without compact spare tire

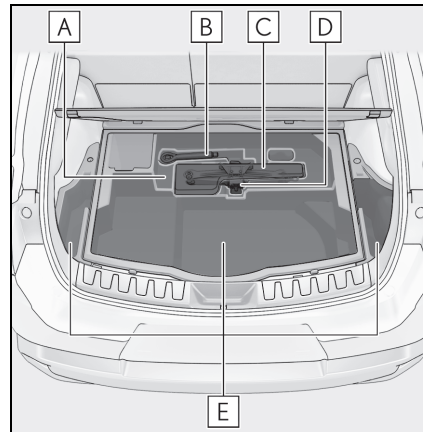

A Warning reflector*

B Towing eyelet

C Tool bag (if equipped)

D Jack (if equipped)

E Accessories

*: The warning reflector itself is not included as an original equipment.

► Vehicles with compact spare tire

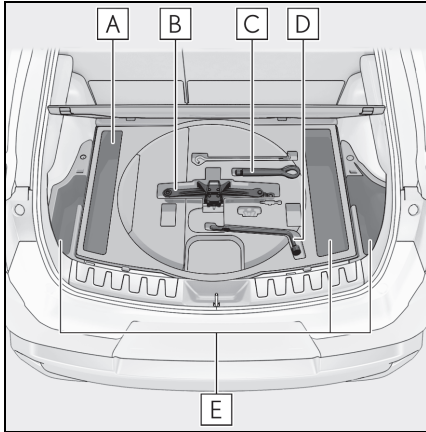

- A** Warning reflector *
- B** Jack
- C** Towing eyelet
- D** Wheel nut wrench
- E** Accessories

*: The warning reflector itself is not included as an original equipment.

■ **Warning reflector**

Depending on the size and shape of the warning reflector case, you may not be able to store it.

Deck board

► Center

- 1 Open the back door.

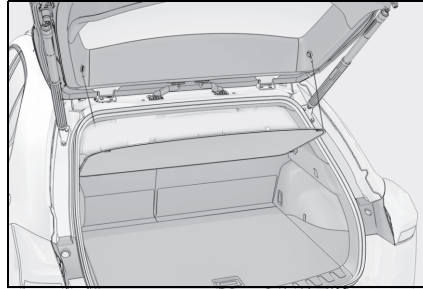

- 2 Pull the lever upwards and open the deck board.

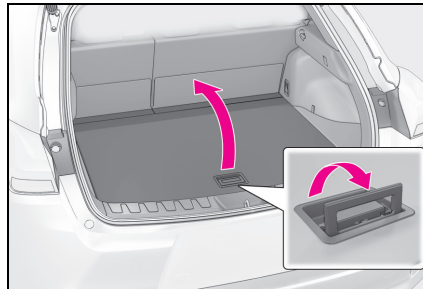

- 3 Unhook the string on the backside of the deck board.

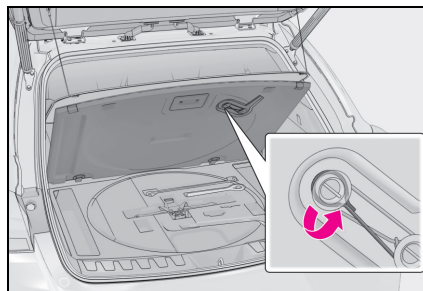

- 4 Attach the string to the luggage cover hook on the back door.

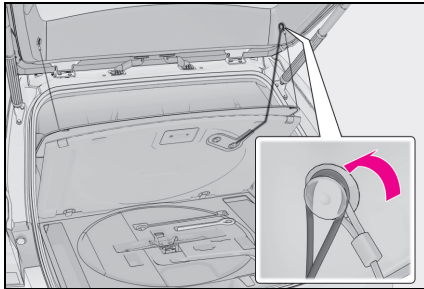

► Side

Pull the strap upwards to lift the side deck board and remove it.

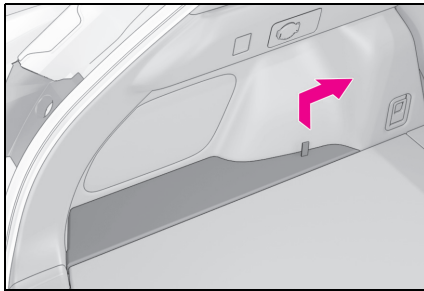

■ When installing the side deck board

Insert the claw of the side deck board and install it.

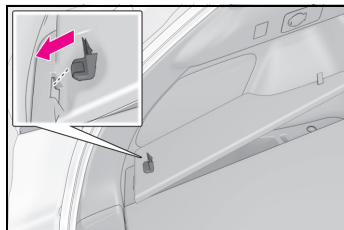

! WARNING

■ If the deck boards are opened or removed

Return them to their original positions before driving. In the event of sudden braking, an accident may occur due to an occupant being struck by the deck boards or the items stored in the deck under tray.

! NOTICE

■ To prevent damage to the deck board

When closing the back door, do not leave the deck board string attached to the hook.

Luggage cover

■ Installing the luggage cover

- 1 Take out the luggage cover from the bag.
- 2 Slowly unfold the luggage cover.
- 3 Attach the strings to the luggage cover hooks.

Make sure that the side the strings are

sewn faces down.

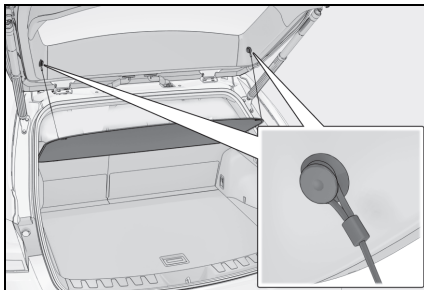
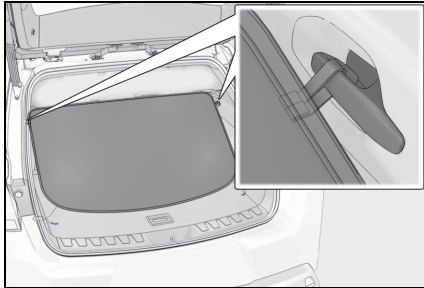

■ **Stowing the luggage cover**

1 Hold the luggage cover corners of the side with the long strings.

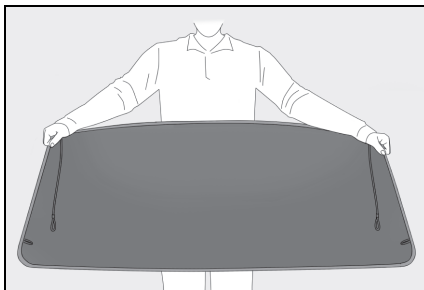

2 Fold it in half.

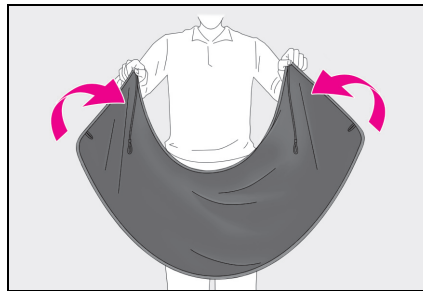

3 Turn your wrists to fold it.

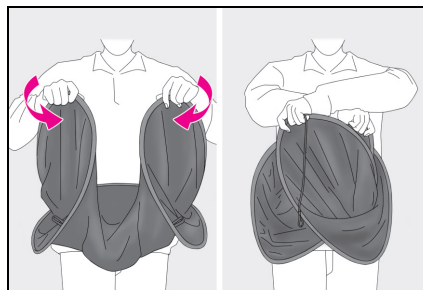

4 Put it in the bag.

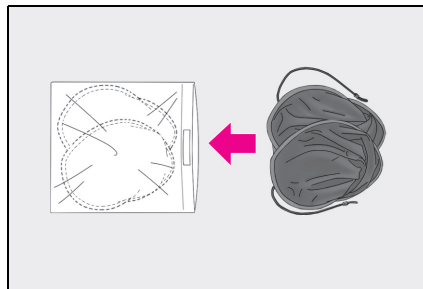

■ **When removing the luggage cover**

Pull the short strings toward you and unhook them.

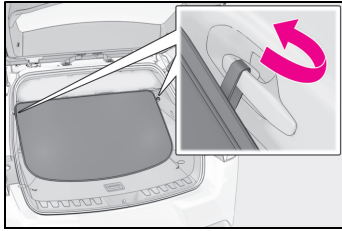

⚠ WARNING

■ When removing and unfolding the luggage cover

Observe the following precautions. Failure to do so may cause the luggage cover to suddenly unfold, resulting in injury.

- When taking out the luggage cover from the bag, securely hold the edges of the luggage cover and slowly take it out.
- When unfolding the luggage cover, hold it securely in both hands and slowly unfold it.
- Do not unfold the luggage cover near your face.
- When unfolding the luggage cover, do not release your hand from the cover.
- Do not unfold the luggage cover near other people.

■ When installing the luggage cover

Observe the following precautions. Failure to do so may cause an accident.

- Make sure that the rear edge of the luggage cover is laying flat to prevent the driver's view from being obstructed.
- Make sure to attach the strings correctly.

⚠ NOTICE

■ When using the luggage cover

- Do not place anything on the luggage cover. Doing so may deform the luggage cover.
- Do not open or close the back door with the strings unhooked. Doing so may cause damage to the luggage cover.
- Do not hook anything other than the luggage cover and deck board strings on the luggage cover hooks. The hooks and back door may be damaged.

Other interior features

Sun visors

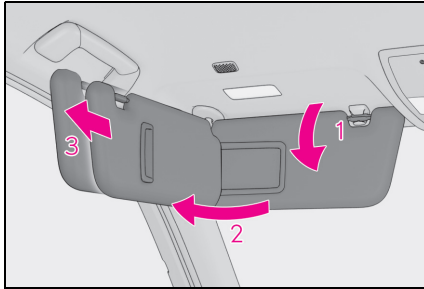

- 1 To set the visor in the forward position, flip it down.
- 2 To set the visor in the side position, flip down, unhook, and swing it to the side.
- 3 To use the side extender, place the visor in the side position, then slide it backward.

When adjusting the inside rear view mirror

Adjust the inside rear view mirror to enable sufficient confirmation of the rear view without interfering with the sun visor.

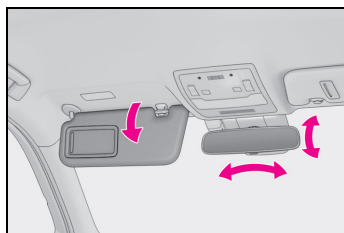

NOTICE

To prevent damage to the sun visors
When using the side extender, do not swing the visor to the front.

Vanity mirrors

Slide the cover to open.

The light turns on when the cover is opened.

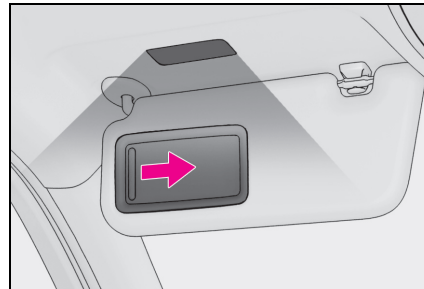

Vanity lights

If the vanity lights remain on when the engine switch is turned off, the lights will go off automatically after 20 minutes.

NOTICE

To prevent battery discharge
Do not leave the vanity lights on for extended periods while the engine is off.

Clock

The GPS clock's time is automatically adjusted by utilizing GPS time information.

For details, refer to the "NAVIGATION AND MULTIMEDIA SYSTEM OWNER'S MANUAL".

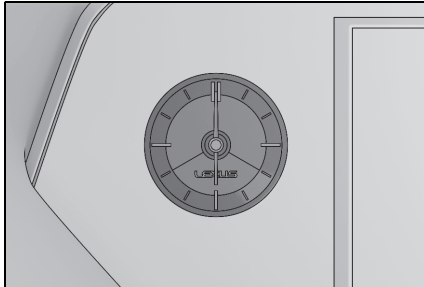

Power outlet

Please use a power supply for electronic goods that use less than 12 VDC/10 A (power consumption of 120 W).

When using electronic goods, make sure that the power consumption of all the connected power outlets is less than 120 W.

► Front

Press down the lid to open it.

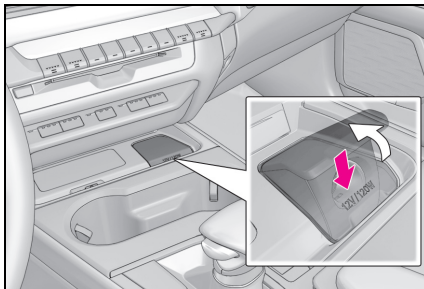

► Rear

Open the lid.

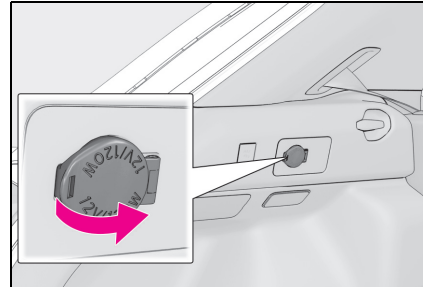

■ The power outlet can be used when

The engine switch is in ACC or ON.

⚠ NOTICE

■ When power outlet is not in use

To avoid damaging the power outlet, close the power outlet lid when the power outlet is not in use. Foreign objects or liquids that enter the power outlet may cause a short circuit.

■ To prevent battery discharge

Do not use the power outlet longer than necessary when the engine is off.

■ To prevent incorrect operation of the vehicle

When turning the engine switch off, make sure to disconnect accessories designed for charging, such as portable chargers, power banks, etc. from the power outlets.

If such an accessory is left connected, the following may occur:

- The doors will not be able to be locked.
- The opening screen will be displayed on the multi-information display.
- The interior lights, instrument panel lights, etc. will illuminate.

USB charging ports

The USB charging ports are used to supply 2.1 A of electricity at 5 V to external devices.

The USB charging ports are for charging only. They are not designed for data transfer or other purposes. Depending on the external device, it may not charge properly. Refer to the manual included with the device before using a USB charging port.

■ Using the USB charging ports

Open the lid.

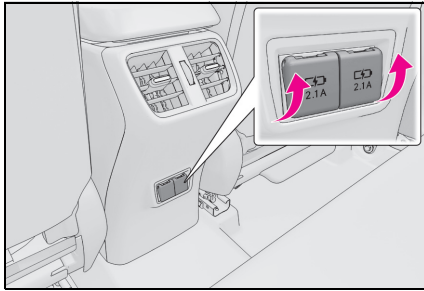

■ The USB charging ports can be used when

The engine switch is in ACC or ON.

■ Situations in which the USB charging ports may not operate correctly

- If a device which consumes more than 2.1 A at 5 V is connected
- If a device designed to communicate with a personal computer, such as a USB memory device, is connected
- If the connected external device is turned off (depending on device)
- If the temperature inside the vehicle is high, such as after the vehicle has been parked in the sun

■ About connected external devices

Depending on the connected external

device, charging may occasionally be suspended and then start again. This is not a malfunction.

⚠ NOTICE

■ To prevent damage to the USB charging ports

- Do not insert foreign objects into the ports.
- Do not spill water or other liquids into the ports.
- When the USB charging ports are not in use, close the lids. If a foreign object or liquid enters a port may cause a short circuit.
- Do not apply excessive force to or impact the USB charging ports.
- Do not disassemble or modify the USB charging ports.

■ To prevent damage to external devices

- Do not leave external devices in the vehicle. The temperature inside the vehicle may become high, resulting in damage to an external device.
- Do not push down on or apply unnecessary force to an external device or the cable of an external device while it is connected.

■ To prevent battery discharge

Do not use the USB charging ports for a long period of time with the engine stopped.

Wireless charger (if equipped)

A portable device, such as a smartphone or mobile battery, can be charged by just placing it on the charging area, provided the device is compatible with the Qi wireless charging standard created by the

Wireless Power Consortium.

The wireless charger cannot be used with a portable device that is larger than the charging area. Additionally, depending on the portable device, the wireless charger may not operate properly. Refer to the operation manual of the portable device.

■ The “Qi” symbol

The “Qi” symbol is a trademark of the Wireless Power Consortium.



■ Name for all parts

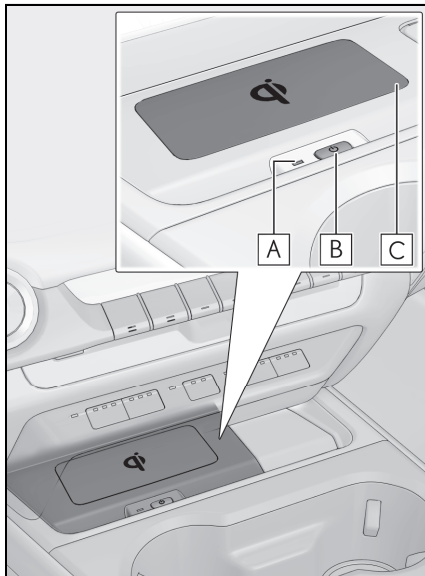

A Operation indicator light

B Power supply switch

C Charge area

■ Using the wireless charger

- 1 Press the power supply switch of the wireless charger.

Pressing the switch again turns the wireless charger off.

When turned on, the operation indicator light (green) comes on.

When the engine switch is turned off, the on/off state of the wireless charger will be memorized.

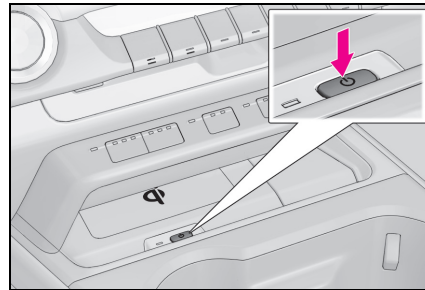

- 2 Place a portable device on the charging area with its charging surface facing down.

While charging, the operation indicator light (orange) will be illuminated.

If charging does not begin, move the portable device as close to the center of the charging area as possible.

When charging is complete, the operation indicator light (green) will illuminate.

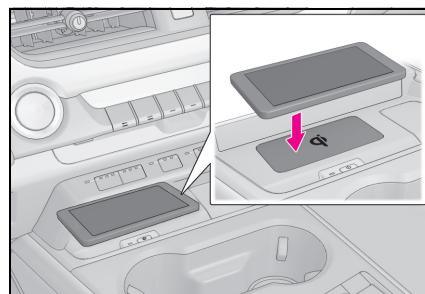

■ Recharging function

- If a certain amount of time has elapsed since charging completed

and the portable device has not been moved, the wireless charger will restart charging.

- If the portable device is moved within the charging area, charging will stop temporarily then restart.

■ **Operation indicator light status**

Operation indicator light	State
Off	The Wireless charger is off
Green (illuminated)	Standby (charging is possible)
	Charging is complete*
Orange (illuminated)	A portable device has been placed on the charging area (identifying the portable device)
	Charging in progress

*: Depending on the portable device, the operation indicator light may stay illuminated (orange) after charging has completed.

- If the operation indicator light blinks

If an error is detected, the operation indicator light will blink (orange). Take the appropriate measures according to the table below.

- Blinks (orange) at a one second interval continuously

Suspected causes	Measure
Vehicle to charger communication failure.	Contact any authorized Lexus retailer or Lexus authorized repairer, or any reliable repairer.

- Blinks (orange) 3 times repeatedly

Suspected causes	Measure
A foreign object exists between the portable device and charging area.	Remove the foreign object.
Portable device is not positioned properly on the charging area.	Move the portable device toward the center of the charging area.

- Blinks (orange) 4 times repeatedly

Suspected causes	Measure
The temperature of the wireless charger is excessively high.	Stop charging immediately and continue charging after a while.

■ **The wireless charger can be operated when**

The engine switch is in ACC or ON.

■ **Portable devices that can be charged**

- Portable devices compatible with the Qi wireless charging standard can be charged by the wireless charger. However, compatibility with all devices which meet the Qi wireless charging standard is not guaranteed.
- The wireless charger is designed to supply low power electricity (5 W or less) to a cellular phone, smartphone, or other portable device.

■ If a cover or accessory is attached to the portable device

Do not charge a portable device if a cover or accessory which is not Qi compatible is attached. Depending on the type of cover and/or accessory attached, it may not be possible to charge the portable device. If the portable device is placed on the charging area and does not charge, remove the cover and/or accessories.

■ If interference is heard in AM radio broadcasts while charging

Turn off the wireless charger and check if the noise is reduced. If noise is reduced, press and hold the power supply switch of the wireless charger for 2 seconds. The frequency of the wireless charger is changed and noise may be reduced. When the frequency is changed, the operation indicator light will blink (orange) 2 times.

■ Charging precautions

- If the electronic key cannot be detected in the cabin, charging cannot be performed. When a door is opened and closed, charging may be temporarily suspended.
- While charging, the wireless charger and the portable device will become warm. This is not a malfunction.
If a portable device becomes warm while charging and charging stops due to the protection function of the portable device, wait until the portable device cools down and charge it again.

■ Sound generated during operation

When the power supply switch is turned on or while a portable device is being identified, operation sounds may be heard. This is not a malfunction.

■ Cleaning the wireless charger

→P.393

■ Label indicating precautions for using the wireless charger

There is a label on the vehicle front side of the wireless charger. Follow the instructions on the label.

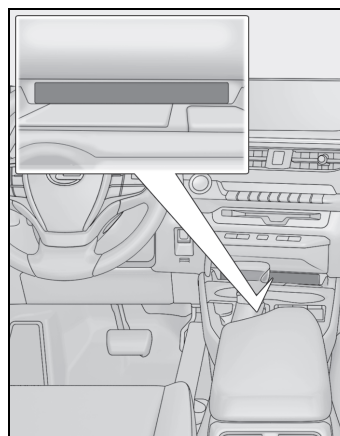

⚠ WARNING

■ Caution while driving

When charging a portable device while driving, for safety reasons, the driver should not operate the portable device.

■ Caution regarding interference with electronic devices

People who use cardiac pacemakers should use the wireless charger separated from the installation part of the cardiac pacemaker by 22 cm (8.7 in.) or more.

■ To prevent damage or burns

Observe the following precautions.

Failure to do so may result in the possibility of fire, equipment failure or damage, or burns due to heat.

- Do not put any metallic objects between the charging area and the portable device while charging.
- Do not place containers with liquid such as water on the wireless charger.
- Do not attach metallic objects, such as aluminum stickers, to the charging area.
- Do not cover the wireless charger with a cloth or other object while charging.

 **WARNING**

- Do not attempt to charge portable devices which are not compatible with the Qi wireless charging standard.
- Do not disassemble, modify or remove the wireless charger.
- Do not apply force or impact to the wireless charger.

 **NOTICE**

■ **Conditions in which the wireless charger may not operate correctly**

In the following situations, the wireless charger may not operate correctly:

- When a portable device is fully charged
- When there is a foreign object between the charging area and portable device
- When a portable device becomes hot while charging
- When a portable device is placed on the charging area with its charging surface facing up
- When a portable device is not centered on the charging area
- When the vehicle is near a TV tower, electric power plant, gas station, radio station, large display, airport or other facility that generates strong radio waves or electrical noise
- When the portable device is in contact with, or is covered by any of the following metallic objects
 - Cards to which aluminum foil is attached
 - Cigarette boxes that have aluminum foil inside
 - Metallic wallets or bags

- Coins
- Metal hand warmers
- Media such as CDs and DVDs
- When wireless keys (that emit radio waves) other than those of your vehicle are being used nearby.

If in situations other than above the wireless charger does not operate properly or the operation indicator light is blinking, the wireless charger may be malfunctioning. Contact any authorized Lexus retailer or Lexus authorized repairer, or any reliable repairer.

■ **To prevent failure or damage to data**

- Do not bring magnetic cards, such as a credit card, or magnetic recording media, close to the wireless charger while charging. Otherwise, data may be erased due to the influence of magnetism. Additionally, do not bring precision instruments such as wrist watches, close to the wireless charger, as such objects may malfunction.

- Do not leave portable devices in the cabin. The temperature inside the cabin may become high when parked in the sun, and cause damage to the device.

■ **To prevent battery discharge**

Do not use the wireless charger for a long period of time with the engine is stopped.

Armrest

Fold down the armrest for use.

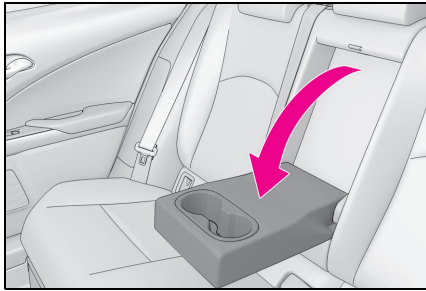

⚠ NOTICE

- **To prevent damage to the armrest**
Do not apply too much load on the armrest.

Coat hooks

The coat hooks are provided with the rear assist grips.

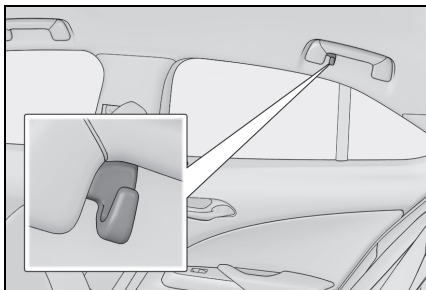

⚠ WARNING

- **Items that must not be hung on the hook**
Do not hang coat hangers or other hard or sharp objects on the hook. If the SRS curtain shield airbags deploy, these items may become projectiles, causing death or serious injury.

Assist grips

An assist grip installed on the ceiling can be used to support your body while sitting on the seat.

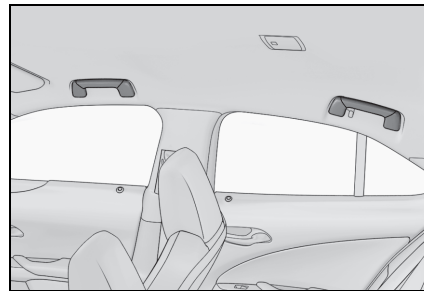

⚠ WARNING

- **Assist grips**
Do not use the assist grip when getting in or out of the vehicle or rising from your seat.

⚠ NOTICE

- **To prevent damage to the assist grip**
Do not hang any heavy object or put a heavy load on the assist grip.

- 6-1. Maintenance and care**
 - Cleaning and protecting the vehicle exterior **390**
 - Cleaning and protecting the vehicle interior **393**
- 6-2. Maintenance**
 - Maintenance requirements.. **396**
- 6-3. Do-it-yourself maintenance**
 - Do-it-yourself service precautions **398**
 - Hood **400**
 - Positioning a floor jack..... **401**
 - Engine compartment..... **402**
 - Tires **409**
 - Tire inflation pressure..... **424**
 - Wheels **425**
 - Air conditioning filter..... **426**
 - Electronic key battery **428**
 - Checking and replacing fuses **430**
 - Light bulbs..... **432**

Cleaning and protecting the vehicle exterior

Perform cleaning in a manner appropriate to each component and its material.

Cleaning instructions

- Working from top to bottom, liberally apply water to the vehicle body, wheel wells and underside of the vehicle to remove any dirt and dust.
- Wash the vehicle body using a sponge or soft cloth, such as a chamois.
- For hard-to-remove marks, use car wash soap and rinse thoroughly with water.
- Wipe away any water.
- Wax the vehicle when the waterproof coating deteriorates.

If water does not bead on a clean surface, apply wax when the vehicle body is cool.

■ Self-restoring coat

The vehicle body has a self-restoring coating that is resistant to small surface scratches caused in a car wash, etc.

- The coating lasts for 5 to 8 years from when the vehicle is delivered from the plant.
- The restoration time differs depending on the depth of the scratch and outside temperature. The restoration time may become shorter when the coating is warmed by applying warm water.
- Deep scratches caused by keys, coins, etc., cannot be restored.

- Do not use wax that contain abrasives.

■ Automatic car washes

- Before washing the vehicle:
 - Fold the mirrors
 - Turn off the power back door (if equipped)

Start washing from the front of the vehicle.

Extend the mirrors before driving.

- Brushes used in automatic car washes may scratch the vehicle surface and harm your vehicle's paint.
- Rear spoiler may not be washable in some automatic car washes. There may also be an increased risk of damage to vehicle.

■ High pressure car washes

- Do not allow the nozzles of the car wash to come within close proximity of opening and closing part of the doors or side windows, and do not continuously let water hit at the same place.
- Before using the car wash, check that the fuel filler door on your vehicle is closed properly.

■ Note for a smart entry & start system (if equipped)

- If the door handle becomes wet while the electronic key is within the effective range, the door may lock and unlock repeatedly. In that case, follow the following correction procedures to wash the vehicle:
 - Place the key in a position 2 m (6 ft.) or more separate from the vehicle while the vehicle is being washed. (Take care to ensure that the key is not stolen.)
 - Set the electronic key to battery-saving mode to disable the smart entry & start system. (→P.152)
- If the electronic key is inside the vehicle and a door handle becomes wet during a car wash, a buzzer may sound outside the vehicle and "Key Detected in Vehicle" may be shown on the multi-information display. To turn off the alarm, lock all the doors.

■ Aluminum wheels

- Remove any dirt immediately by using a neutral detergent.
- Wash detergent off with water immediately after use.
- To protect the paint from damage, make sure to observe the following precautions.
 - Do not use acidic, alkaline or abrasive detergent.
 - Do not use hard brushes.
 - Do not use detergent on the wheels when they are hot, such as after driving or parking in hot weather.

■ Bumpers

Do not scrub with abrasive cleaners.

■ Front side windows water-repellent coating

- The following precautions can extend the effectiveness of the water-repellent coating.
 - Remove any dirt, etc., from the front side windows regularly.
 - Do not allow dirt and dust to accumulate on the windows for a long period.

Clean the windows with a soft, damp cloth as soon as possible.

- Do not use wax or glass cleaners that contain abrasives when cleaning the windows.
- Do not use any metallic objects to remove condensation build up.
- When the water-repellent performance has become insufficient, the coating can be repaired. Contact any authorized Lexus retailer or Lexus authorized repairer, or any reliable repairer.



WARNING

■ When washing the vehicle

Do not apply water to the inside of the engine compartment. Doing so may cause the electrical components, etc. to catch fire.

■ When cleaning the windshield (vehicles with rain-sensing windshield wipers)

Set the wiper switch to off. If the wiper switch is in AUTO, the wipers may operate unexpectedly in the following situations, and may result in hands being caught or other serious injuries and cause damage to the wiper blades.

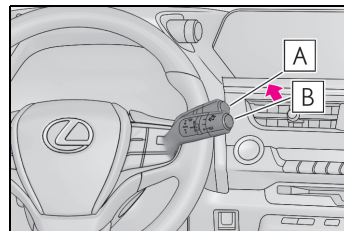

A Off

B AUTO

- When the upper part of the windshield where the raindrop sensor is located is touched by hand
- When a wet rag or similar is held close to the raindrop sensor
- If something bumps against the windshield
- If you directly touch the raindrop sensor body or if something bumps into the raindrop sensor

■ Precautions regarding the exhaust pipe

Exhaust gasses cause the exhaust pipe to become quite hot.

When washing the vehicle, be careful not to touch the pipe and the muffler cutter (if equipped) until it has cooled sufficiently, as touching a hot exhaust pipe can cause burns.

**WARNING****■ Precaution regarding the rear bumper**

If the paint of the rear bumper is chipped or scratched, the following systems may not function correctly. If this occurs, consult any authorized Lexus retailer or Lexus authorized repairer, or any reliable repairer.

- Lexus Safety System+ (if equipped)
- BSM (if equipped)
- RCTA (if equipped)
- PKSB (if equipped)

**NOTICE****■ To prevent paint deterioration and corrosion on the body and components (aluminum wheels, etc.)**

- Wash the vehicle immediately in the following cases:
 - After driving near the sea coast
 - After driving on salted roads
 - If coal tar or tree sap is present on the paint surface
 - If dead insects, insect droppings or bird droppings are present on the paint surface
 - After driving in an area contaminated with soot, oily smoke, mine dust, iron powder or chemical substances
 - If the vehicle becomes heavily soiled with dust or mud
 - If liquids such as benzene and gasoline are spilled on the paint surface
- If the paint is chipped or scratched, have it repaired immediately.
- To prevent the wheels from corroding, remove any dirt and store in a place with low humidity when storing the wheels.

■ Cleaning the exterior lights

- Wash carefully. Do not use organic substances or scrub with a hard brush. This may damage the surfaces of the lights.
- Do not apply wax to the surfaces of the lights. Wax may cause damage to the lenses.

■ When using an automatic car wash (vehicles with rain-sensing windshield wipers)

Set the wiper switch to the off position. If the wiper switch is in AUTO, the wipers may operate and the wiper blades may be damaged.

■ When using a high pressure car wash

- When washing the vehicle, do not let water of the high pressure washer hit directly or the vicinity of the camera. Due to the shock from the high pressure water, it is possible the device may not operate as normal.
- Do not bring the nozzle tip close to boots (rubber or resin manufactured cover), connectors or the following parts. The parts may be damaged if they come into contact with high-pressure water.
 - Traction related parts
 - Steering parts
 - Suspension parts
 - Brake parts
- Keep the cleaning nozzle at least 30 cm (11.9 in.) away from the vehicle body. Otherwise resin section, such as molding and bumpers, may be deformed and damaged. Also, do not continuously hold the nozzle in the same place.
- Do not continuously let water hit at the lower part of the windshield. As there is the air inlet vents, the air conditioning system may not operate properly.

Cleaning and protecting the vehicle interior

Perform cleaning in a manner appropriate to each component and its material.

Protecting the vehicle interior

- Remove dirt and dust using a vacuum cleaner. Wipe dirty surfaces with a cloth dampened with lukewarm water.
- If dirt cannot be removed, wipe it off with a soft cloth dampened with neutral detergent diluted to approximately 1%.
Wring out any excess water from the cloth and thoroughly wipe off remaining traces of detergent and water.

■ Shampooing the carpets

There are several commercial foaming-type cleaners available. Use a sponge or brush to apply the foam. Rub in overlapping circles. Do not use water. Wipe dirty surfaces and let them dry. Excellent results are obtained by keeping the carpet as dry as possible.

■ Handling the seat belts

Clean with mild soap and lukewarm water using a cloth or sponge. Also check the belts periodically for excessive wear, fraying or cuts.

■ Front side windows with UV protective coating (vehicles with UV protective coating)

The front side windows have UV protective coating. To prevent any damage to the UV protective coating, observe the following:

- If the windows are dirty, gently wipe them with a cloth soaked in water or lukewarm water as soon as possible.
- If the windows are very dirty, do not open and close them repeatedly.

WARNING

■ Water in the vehicle

- Do not splash or spill liquid in the vehicle.
Doing so may cause electrical components, etc., to malfunction or catch fire.
- Do not get any of the SRS components or wiring in the vehicle interior wet. (→P.38)
An electrical malfunction may cause the airbags to deploy or not function properly, resulting in death or serious injury.
- Vehicles with wireless charger: Do not let the wireless charger (→P.382) get wet. Failure to do so may cause the charger to become hot and cause burns or could cause electric shock resulting in death or serious injury.

■ Cleaning the interior (especially instrument panel)

Do not use a polish wax or polish cleaner. The instrument panel may reflect off the windshield, obstructing the driver's view and leading to an accident, resulting in death or serious injury.

**NOTICE****■ Cleaning detergents**

- Do not use the following types of detergent, as they may discolor the vehicle interior or cause streaks or damage to painted surfaces:
 - Non-seat portions: Organic substances such as benzene or gasoline, alkaline or acidic solutions, dye, and bleach
 - Seats: Alkaline or acidic solutions, such as thinner, benzene, and alcohol
- Do not use a polish wax or polish cleaner. The instrument panel's or other interior part's painted surface may be damaged.

■ Water on the floor

Do not wash the vehicle floor with water. Vehicle systems such as the audio system may be damaged if water comes into contact with electrical components such as the audio system above or under the floor of the vehicle. Water may also cause the body to rust.

■ When cleaning the inside of the windshield (vehicles with Lexus Safety System+)

Do not allow glass cleaner to contact the lens. Also, do not touch the lens. (→P.249)

■ Cleaning the inside of the rear window

- Do not use a glass cleaner to clean the rear window, as this may cause damage to the rear window defogger heater wires or antenna. Use a cloth dampened with lukewarm water to gently wipe the window clean. Wipe the window in strokes running parallel to the heater wires or antenna.
- Be careful not to scratch or damage the heater wires or antenna.

■ Cleaning the front side windows

Do not use any compound or abrasive product (e.g., glass cleaner, detergent, wax) to clean the windows. It may damage the coating.

Cleaning the areas with satin-finish metal accents

- Remove dirt using a water-dampened soft cloth or synthetic chamois.
- Wipe the surface with a dry soft cloth to remove any remaining moisture.

■ Cleaning the areas with satin-finish metal accents

The metal areas use a layer of real metal for the surface. It is necessary to clean them regularly. If dirty areas are left uncleaned for long periods of time, they may be difficult to clean.

Cleaning the leather areas**■ Cleaning the leather**

- Remove dirt and dust using a vacuum cleaner.
- Wipe off any excess dirt and dust with a soft cloth dampened with diluted detergent. Use a diluted water solution of approximately 5% neutral wool detergent.
- Wring out any excess water from the cloth and thoroughly wipe off all remaining traces of detergent.
- Wipe the surface with a dry, soft cloth to remove any remaining moisture.

Allow the leather to dry in a shaded and ventilated area.

■ Cleaning the synthetic leather

- Remove dirt and dust using a vacuum cleaner.
- If the area gets dirty, wipe it off with a soft cloth dampened with water and wrung out.
- If dirt cannot be removed by wiping with water, wipe it off using cleaner for leather.

■ Caring for leather areas

Lexus recommends cleaning the interior of the vehicle at least twice a year to maintain the quality of the vehicle's interior.

■ Dirt on the synthetic leather areas

Ingrained dirt which has been left uncleaned for long periods of time is difficult to clean. Lexus recommends cleaning the area regularly.



NOTICE

■ Preventing damage to leather surfaces

Observe the following precautions to avoid damage to and deterioration of leather surfaces:

- Remove any dust or dirt from leather surfaces immediately.
- Do not expose the vehicle to direct sunlight for extended periods of time. Park the vehicle in the shade, especially during summer.
- Do not place items made of vinyl, plastic, or containing wax on the upholstery, as they may stick to the leather surface if the vehicle interior heats up significantly.

Maintenance requirements

To ensure safe and economical driving, day-to-day care and regular maintenance are essential. Lexus recommends the following maintenance:

■ Where to go for maintenance service?

In order to maintain your vehicle in the best possible condition, Lexus recommends that maintenance service operations as well as other inspections and repairs be carried out by authorized Lexus retailers or Lexus authorized repairers, or any reliable repairers. For repairs and services covered by your warranty, please visit an authorized Lexus retailer or repairer, who will use genuine Lexus parts in repairing any difficulties you may encounter. There can also be advantages in utilizing authorized Lexus retailers or repairers for non-warranty repairs and services, as members of the Lexus network will be able to expertly assist you with any difficulties you may encounter. Your Lexus retailer or Lexus authorized repairer, or any reliable repairer will perform all of the scheduled maintenance on your vehicle reliably and economically due to their experience with Lexus vehicles.

WARNING

■ If your vehicle is not properly maintained

Improper maintenance could result in serious damage to the vehicle and possible serious injury or death.

■ Handling of the battery

Battery posts, terminals and related accessories contain lead and lead compounds which are known to cause brain damage. Wash your hands after handling. (→P.406)

Scheduled maintenance

Scheduled maintenance should be performed at specified intervals according to the maintenance schedule.

For full details of your maintenance schedule, refer to the “Lexus Service Booklet” or “Lexus Warranty Booklet”.

Do-it-yourself maintenance

What about do-it-yourself maintenance?

Many maintenance items are easy to do yourself if you have a little mechanical ability and a few basic automotive tools.

Note, however, that some maintenance tasks require special tools and skills. These are best performed by qualified technicians. Even if you're an experienced do-it-yourself mechanic, we recommend that repairs and maintenance be conducted by any authorized Lexus retailer or Lexus authorized repairer, or any reliable repairer. Any authorized Lexus retailer or repairer will keep a record of maintenance, which could be useful should you ever require Warranty Service. Should you choose to select a qualified and equipped professional other than an authorized Lexus repairer to service or maintain your vehicle, we recommend that you request that a record of maintenance be kept.

■ Does your vehicle need repairs?

Be on the alert for changes in performance and sounds, and visual tip-offs that indicate service is needed. Some important clues are:

- Engine missing, stumbling or pinging
- Appreciable loss of power

- Strange engine noises
- A fluid leak under the vehicle (However, water dripping from the air conditioning system after use is normal.)
- Change in exhaust sound (This may indicate a dangerous carbon monoxide leak. Drive with the windows open and have the exhaust system checked immediately.)
- Flat-looking tires, excessive tire squeal when cornering, uneven tire wear
- Vehicle pulls to one side when driven straight on a level road
- Strange noises related to suspension movement
- Loss of brake effectiveness, spongy feeling brake pedal, pedal almost touches the floor, vehicle pulls to one side when braking
- Engine coolant temperature continually higher than normal (→P.108, 111)

If you notice any of these clues, take your vehicle to any authorized Lexus retailer or Lexus authorized repairer, or any reliable repairer as soon as possible. Your vehicle may need adjustment or repair.

Do-it-yourself service precautions

If you perform maintenance by yourself, be sure to follow the correct procedure as given in these sections.

Maintenance

Items	Parts and tools
Battery condition (→P.406)	<ul style="list-style-type: none"> • Warm water • Baking soda • Grease • Conventional wrench (for terminal clamp bolts)
Engine coolant level (→P.404)	<ul style="list-style-type: none"> • “Toyota Super Long Life Coolant” or a similar high quality ethylene glycol-based non-silicate, non-amine, non-nitrite and non-borate coolant with long-life hybrid organic acid technology • “Toyota Super Long Life Coolant” is pre-mixed with 50% coolant and 50% deionized water. • Funnel (used only for adding coolant)
Engine oil level (→P.402)	<ul style="list-style-type: none"> • “Toyota Genuine Motor Oil” or equivalent • Rag or paper towel • Funnel (used only for adding engine oil)

Items	Parts and tools
Fuses(→P.430)	<ul style="list-style-type: none"> • Fuse with same amperage rating as original
Light bulbs (→P.432)	<ul style="list-style-type: none"> • Bulb with same number and wattage rating as original
Radiator and condenser (→P.405)	–
Tire inflation pressure (→P.424)	<ul style="list-style-type: none"> • Tire pressure gauge • Compressed air source
Washer fluid (→P.408)	<ul style="list-style-type: none"> • Water or washer fluid containing antifreeze (for winter use) • Funnel (used only for adding water or washer fluid)

⚠ WARNING

The engine compartment contains many mechanisms and fluids that may move suddenly, become hot, or become electrically energized. To avoid death or serious injury, observe the following precautions.

■ **When working on the engine compartment**

- Keep hands, clothing and tools away from the moving fan and engine drive belt.
- Be careful not to touch the engine, radiator, exhaust manifold, etc., right after driving as they may be hot. Oil and other fluids may also be hot.
- Do not leave anything that may burn easily, such as paper and rags, in the engine compartment.
- Do not smoke, cause sparks or expose an open flame to fuel or the battery. Fuel and battery fumes are flammable.
- Be extremely cautious when working on the battery. It contains poisonous and corrosive sulfuric acid.
- Take care because brake fluid can harm your hands or eyes and damage painted surfaces. If fluid gets on your hands or in your eyes, flush the affected area with clean water immediately. If you still experience discomfort, consult a doctor.

■ **When working near the electric cooling fan or radiator grille**

Be sure the engine switch is OFF. With the engine switch in ON, the electric cooling fan may automatically start to run if the air conditioning is on and/or the coolant temperature is high. (→P.405)

■ **Safety glasses**

Wear safety glasses to prevent flying or falling material, fluid spray, etc., from getting in your eyes.

⚠ NOTICE

■ **If you remove the air cleaner filter**

Driving with the air cleaner filter removed may cause excessive engine wear due to dirt in the air.

■ **If the fluid level is low or high**

It is normal for the brake fluid level to go down slightly as the brake pads wear or when the fluid level in the accumulator is high.

If the reservoir needs frequent refilling, it may indicate a serious problem.

Hood

Opening the hood

- 1 Pull the hood lock release lever.
The hood will pop up slightly.

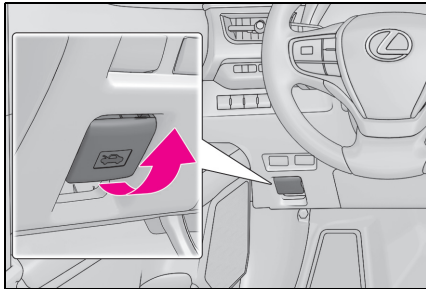

- 2 Pull up the auxiliary catch lever and lift the hood.

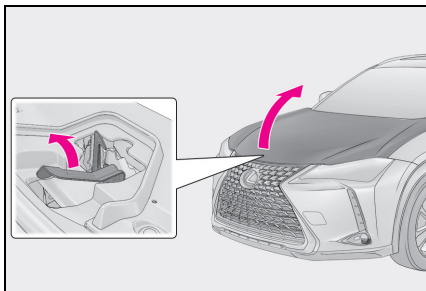

- 3 Hold the hood open by inserting the supporting rod into the slot.

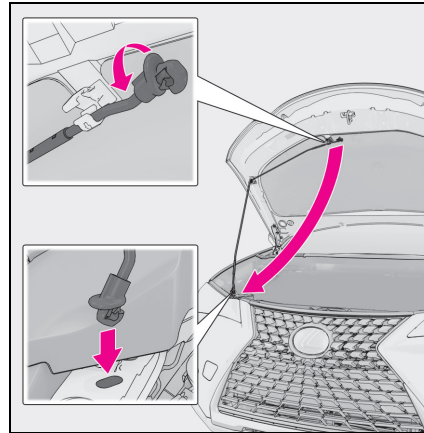

⚠ WARNING

■ Pre-driving check

Check that the hood is fully closed and locked.
If the hood is not locked properly, it may open while the vehicle is in motion and cause an accident, which may result in death or serious injury.

■ After installing the support rod into the slot

Make sure the rod is properly inserted into the slot to prevent the hood from shutting on your head or body.

⚠ NOTICE

■ When closing the hood

Be sure to return the support rod to its clip before closing the hood. Closing the hood without returning the support rod properly may cause the hood to be damaged.

Positioning a floor jack

When using a floor jack, follow the instructions in the manual provided with the jack and perform the operation safely.

When raising your vehicle with a floor jack, position the jack correctly. Improper placement may damage your vehicle or cause injury.

Location of the jack point

■ Front

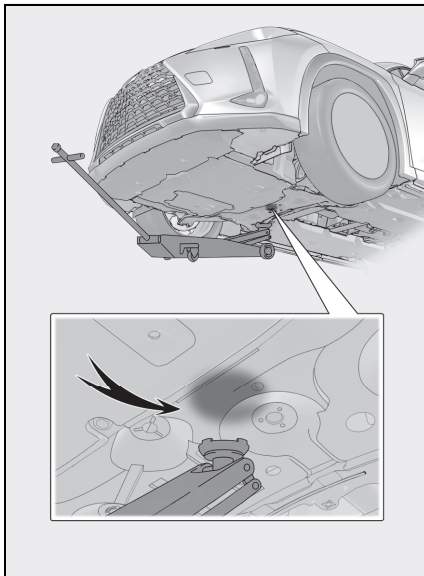

■ Rear

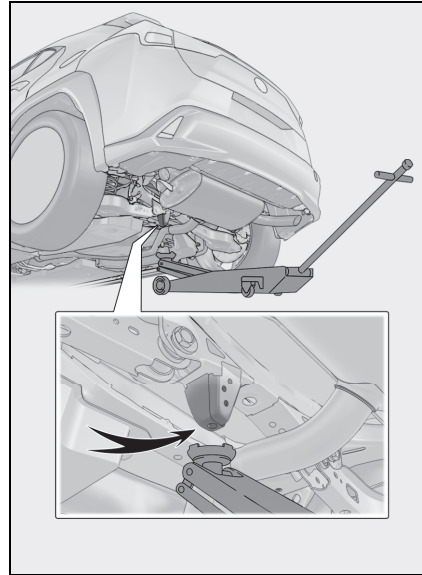

Engine compartment

Components

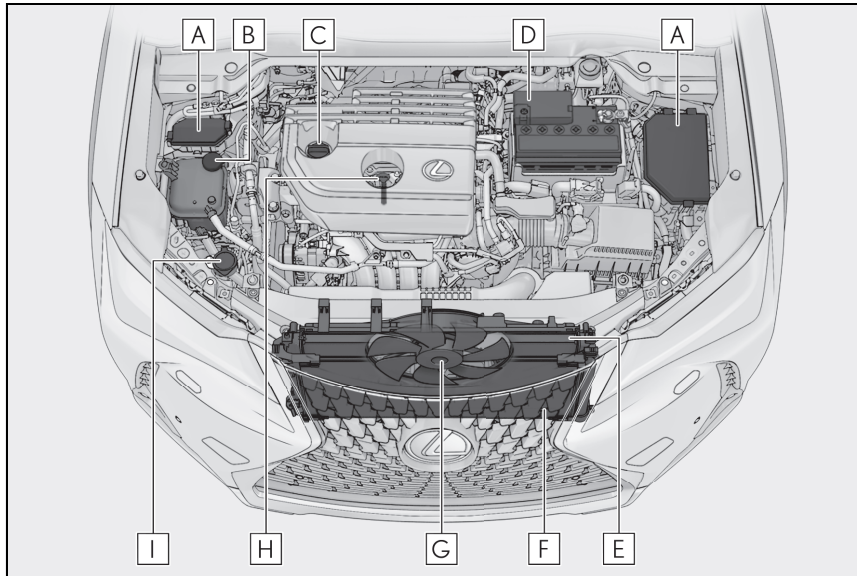

- A** Fuse boxes (→P.430)
- B** Engine coolant reservoir (→P.405)
- C** Engine oil filler cap (→P.403)
- D** Battery (→P.406)
- E** Radiator (→P.405)
- F** Condenser (→P.405)
- G** Electric cooling fan
- H** Engine oil level dipstick (→P.402)
- I** Washer fluid tank (→P.408)

Checking and adding the engine oil

With the engine at operating temperature and turned off, check the oil level

on the dipstick.

■ Checking the engine oil

- 1** Park the vehicle on level ground. After warming up the engine and turning off the engine, wait more

than 5 minutes for the oil to drain back into the bottom of the engine.

- 2 Holding a rag under the end, pull the dipstick out.

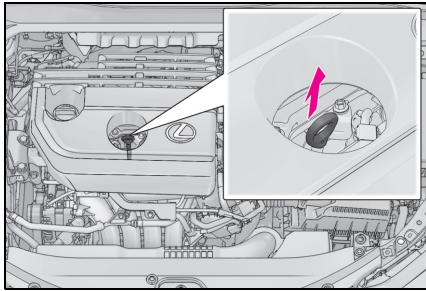

- 3 Wipe the dipstick clean.
- 4 Reinsert the dipstick fully.
- 5 Holding a rag under the end, pull the dipstick out and check the oil level.

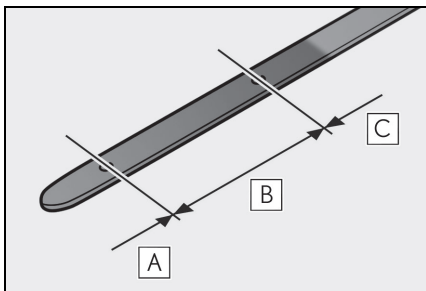

- A** Low
- B** Normal
- C** Excessive

The shape of the dipstick may differ depending on the type of vehicle or engine.

- 6 Wipe the dipstick and reinsert it fully.

■ Checking the oil type and preparing the items needed

Make sure to check the oil type and prepare the items needed before adding oil.

- Engine oil selection

→P.493

- Oil quantity (Low → Full)

1.5 L (1.6 qt., 1.3 Imp.qt.)

- Item

Clean funnel

■ Adding engine oil

If the oil level is below or near the low level mark, add engine oil of the same type as that already in the engine.

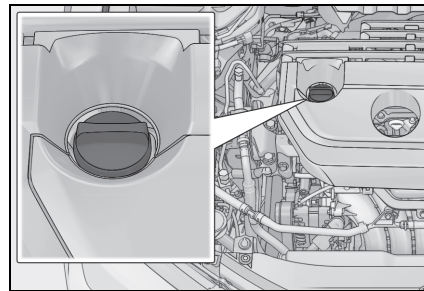

- 1 Remove the oil filler cap by turning it counterclockwise.
- 2 Add engine oil slowly, checking the dipstick.
- 3 Install the oil filler cap by turning it clockwise.

■ Engine oil consumption

A certain amount of engine oil will be consumed while driving. In the following situations, oil consumption may increase, and engine oil may need to be refilled in between oil maintenance intervals.

- When the engine is new, for example directly after purchasing the vehicle or after replacing the engine
- If low quality oil or oil of an inappropriate viscosity is used
- When driving at high engine speeds or with a heavy load, when towing, or when driving while accelerating or decelerating frequently
- When leaving the engine idling for a long time, or when driving frequently through heavy traffic

■ **After changing the engine oil**

The engine oil maintenance data should be reset. Perform the following procedures:

- 1 Press **<** or **>** of the meter control switches and select .
- 2 Press **▲** or **▼** of the meter control switches, select the "Vehicle Settings" and then press "OK".
- 3 Press **▲** or **▼** of the meter control switches, select the "Oil Maintenance" and then press and hold the "OK".
- 4 Select the "Yes" and press "OK".

"Reset Complete" will be displayed when the reset procedure has been completed.

 **WARNING**

- **Used engine oil**
- Used engine oil contains potentially harmful contaminants which may cause skin disorders such as inflammation and skin cancer, so care should be taken to avoid prolonged and repeated contact. To remove used engine oil from your skin, wash thoroughly with soap and water.

- Dispose of used oil and filters only in a safe and acceptable manner. Do not dispose of used oil and filters in household trash, in sewers or onto the ground. Call any authorized Lexus retailer or Lexus authorized repairer, or any reliable repairer, service station or auto parts store for information concerning recycling or disposal.
- Do not leave used engine oil within the reach of children.

 **NOTICE**

■ **To prevent serious engine damage**

Check the oil level on a regular basis.

■ **When replacing the engine oil**

- Be careful not to spill engine oil on the vehicle components.
- Avoid overfilling, or the engine could be damaged.
- Check the oil level on the dipstick every time you refill the vehicle.
- Be sure the engine oil filler cap is properly tightened.

Checking the engine coolant

The coolant level is satisfactory if it is between the "FULL" and "LOW" lines on the reservoir when the engine is cold.

■ Engine coolant reservoir

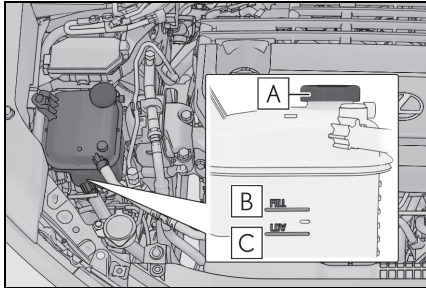

A Reservoir cap

B "FULL" line

C "LOW" line

If the level is on or below the "LOW" line, add coolant up to the "FULL" line. (→P.485)

■ Coolant selection

Only use "Toyota Super Long Life Coolant" or a similar high quality ethylene glycol based non-silicate, non-amine, non-nitrite, and non-borate coolant with long-life hybrid organic acid technology.

"Toyota Super Long Life Coolant" is a mixture of 50% coolant and 50% deionized water. (Minimum temperature: -35°C [-31°F])

For more details about coolant, contact any authorized Lexus retailer or Lexus authorized repairer, or any reliable repairer.

■ If the coolant level drops within a short time of replenishing

Visually check the radiator, hoses, engine coolant reservoir caps, drain cock and water pump.

If you cannot find a leak, have any authorized Lexus retailer or Lexus authorized repairer, or any reliable repairer, test the cap and check for leaks in the cooling system.

⚠ WARNING

■ When the engine is hot

Do not remove the engine coolant reservoir cap. The cooling system may be under pressure and may spray hot coolant if the cap is removed, causing serious injuries, such as burns.

⚠ NOTICE

■ When adding coolant

Coolant is neither plain water nor straight antifreeze. The correct mixture of water and antifreeze must be used to provide proper lubrication, corrosion protection and cooling. Be sure to read the antifreeze or coolant label.

■ If you spill coolant

Be sure to wash it off with water to prevent it from damaging parts or paint.

Checking the radiator and condenser

Check the radiator and condenser, and clear away any foreign objects.

If either of the above parts is extremely dirty or you are not sure of their condition, have your vehicle inspected by any authorized Lexus retailer or Lexus authorized repairer, or any reliable repairer.

⚠ WARNING

■ When the engine is hot

Do not touch the radiator or condenser as they may be hot and cause serious injuries, such as burns.

⚠ WARNING

■ **When the electric cooling fan is operating**

Do not touch the engine compartment. With the engine switch in ON, the electric cooling fan may automatically start to run if the air conditioning is on and/or the coolant temperature is high. Be sure the engine switch is OFF when working near the electric cooling fan or radiator grille.

Checking the battery

Check the battery as follows.

■ **Battery exterior**

Make sure that the battery terminals are not corroded and that there are no loose connections, cracks, or loose clamps.

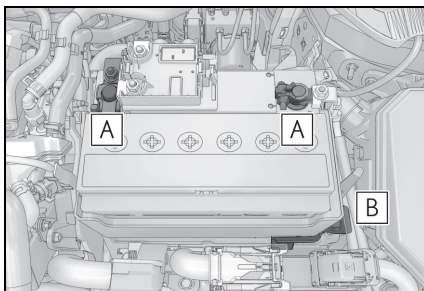

A Terminals

B Hold-down clamp

■ **Checking battery fluid**

Check that the level is between the "UPPER LEVEL" and "LOWER LEVEL" lines.

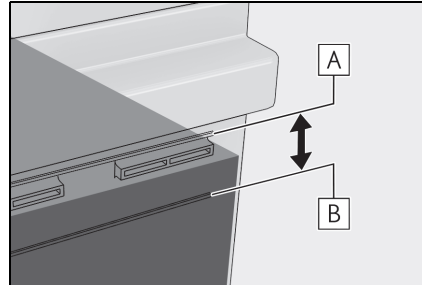

A "UPPER LEVEL" line

B "LOWER LEVEL" line

If the fluid level is at or below the "LOWER LEVEL" line, add distilled water.

■ **Adding distilled water**

- 1 Remove the vent plug.
- 2 Add distilled water.

If the "UPPER LEVEL" line cannot be seen, check the fluid level by looking directly at the cell.

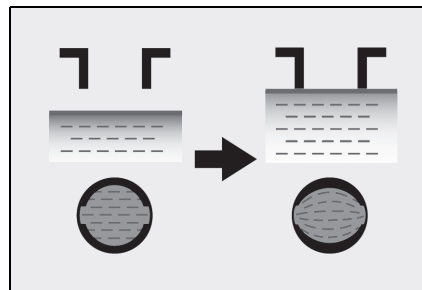

- 3 Put the vent plug back on and close it securely.

■ **Before recharging**

When recharging, the battery produces hydrogen gas which is flammable and explosive. Therefore, observe the following precautions before recharging:

- If recharging with the battery installed on the vehicle, be sure to disconnect the ground cable.
- Make sure the power switch on the char-

ger is off when connecting and disconnecting the charger cables to the battery.

■ **After recharging/reconnecting the battery**

- The engine may not start. Follow the procedure below to initialize the system.
 - 1 Shift the shift lever to P.
 - 2 Open and close any of the doors.
 - 3 Restart the engine.
- Unlocking the doors using the smart entry & start system may not be possible immediately after reconnecting the battery. If this happens, use the wireless remote control or the mechanical key to lock/unlock the doors.
- Start the engine with the engine switch in ACC. The engine may not start with the engine switch turned off. However, the engine will operate normally from the second attempt.
- The engine switch mode is recorded by the vehicle. If the battery is reconnected, the vehicle will return the engine switch mode to the status it was in before the battery was disconnected. Make sure to turn off the engine switch before disconnecting the battery. Take extra care when connecting the battery if the engine switch mode prior to the battery being disconnected is unknown.

If the system will not start even after multiple attempts at all the methods above, contact any authorized Lexus retailer or Lexus authorized repairer, or any reliable repairer.



WARNING

■ **Chemicals in the battery**

Battery contains poisonous and corrosive sulfuric acid and may produce hydrogen gas which is flammable and explosive. To reduce the risk of death or serious injury, take the following precautions while working on or near the battery:

- Do not cause sparks by touching the battery terminals with tools.

- Do not smoke or light a match near the battery.

- Avoid contact with eyes, skin and clothes.

- Never inhale or swallow electrolyte.

- Wear protective safety glasses when working near the battery.

- Keep children away from the battery.

■ **Where to safely charge the battery**

Always charge the battery in an open area. Do not charge the battery in a garage or closed room where there is insufficient ventilation.

■ **Emergency measures regarding electrolyte**

- If electrolyte gets in your eyes
Flush your eyes with clean water for at least 15 minutes and get immediate medical attention. If possible, continue to apply water with a sponge or cloth while traveling to the nearest medical facility.

- If electrolyte gets on your skin
Wash the affected area thoroughly. If you feel pain or burning, get medical attention immediately.

- If electrolyte gets on your clothes
It can soak through clothing on to your skin. Immediately take off the clothing and follow the procedure above if necessary.

- If you accidentally swallow electrolyte
Drink a large quantity of water or milk. Get emergency medical attention immediately.

■ **When there is insufficient battery fluid**

Do not use if there is insufficient fluid in the battery. There is a possible danger that the battery may explode.

 NOTICE

■ **When recharging the battery**

Never recharge the battery while the engine is running. Also, be sure all accessories are turned off.

■ **When adding distilled water**

Avoid overfilling. Water spilled during battery recharging may cause corrosion.

Adding the washer fluid

If none of the washer do not work or the “Windshield Washer Fluid Low” appears on the multi-information display, the washer tank may be empty. Add washer fluid.

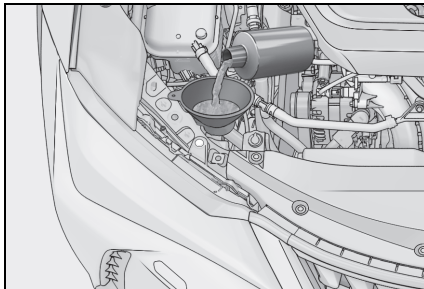

 WARNING

■ **When adding washer fluid**

Do not add washer fluid when the engine is hot or operating as washer fluid contains alcohol and may catch fire if spilled on the engine, etc.

 NOTICE

■ **Do not use any fluid other than washer fluid**

Do not use soapy water or engine anti-freeze instead of washer fluid. Doing so may cause streaking on the vehicle’s painted surfaces, as well as damaging the pump leading to problems of the washer fluid not spraying.

■ **Diluting washer fluid**

Dilute washer fluid with water as necessary. Refer to the freezing temperatures listed on the label of the washer fluid bottle.

Tires

Replace or rotate tires in accordance with maintenance schedules and treadwear.

Checking tires

Check if the treadwear indicators are showing on the tires. Also check the tires for uneven wear, such as excessive wear on one side of the tread.

Check the spare tire condition and pressure if not rotated.

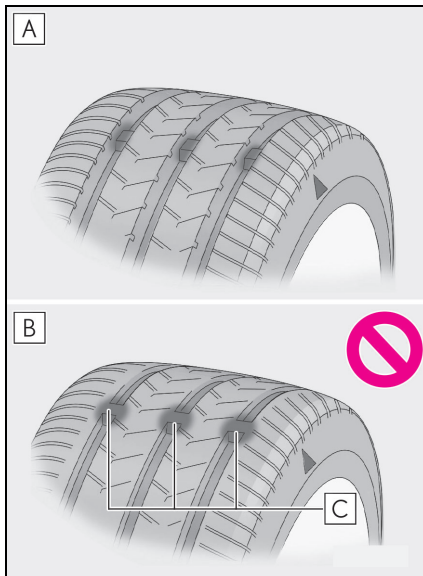

- A** New tread
- B** Worn tread
- C** Treadwear indicator

The location of treadwear indicators is shown by a "TWI" or "△" mark, etc., molded into the sidewall of each tire.

Replace the tires if the treadwear indicators are showing on a tire.

When to replace your vehicle's tires

Tires should be replaced if:

- The treadwear indicators are showing on a tire.
- You have tire damage such as cuts, splits, cracks deep enough to expose the fabric, and bulges indicating internal damage
- A tire goes flat repeatedly or cannot be properly repaired due to the size or location of a cut or other damage

If you are not sure, consult any authorized Lexus retailer or Lexus authorized repairer, or any reliable repairer.

Tire life

Any tire over 6 years old must be checked by a qualified technician even if it has seldom or never been used or damage is not obvious.

If the tread on snow tires wears down below 4 mm (0.16 in.)

The effectiveness of the tires as snow tires is lost.

Replacing tires (vehicles with run-flat tires)

Your vehicle may not be equipped with the following tools and jack for replacing a tire. In this case, when replacing tires with tires that are not run-flat tires, purchase tools and jack. Tools and jack can be purchased at any authorized Lexus retailer or Lexus authorized repairer, or any reliable repairer.

- Wheel nut wrench
- Jack
- Jack handle

⚠ WARNING**■ When inspecting or replacing tires**

Observe the following precautions to prevent accidents. Failure to do so may cause damage to parts of the drivetrain as well as dangerous handling characteristics, which may lead to an accident resulting in death or serious injury.

- Do not mix tires of different makes, models or tread patterns. Also, do not mix tires of remarkably different treadwear.
- Do not use tire sizes other than those recommended by Lexus.
- Do not mix differently constructed tires (radial, bias-belted or bias-ply tires).
- Do not mix summer, all season and snow tires.
- Do not use tires that have been used on another vehicle. Do not use tires if you do not know how they were used previously.
- Vehicles with compact spare tire: Do not tow if your vehicle has a compact spare tire installed.
- Vehicles with emergency tire puncture repair kit: Do not tow anything if a tire that has been repaired using the emergency tire puncture repair kit is installed. The load on the tire may cause unexpected damage to the tire.

⚠ NOTICE**■ Driving on rough roads**

Take particular care when driving on roads with loose surfaces or potholes. These conditions may cause losses in tire inflation pressure, reducing the cushioning ability of the tires. In addition, driving on rough roads may cause damage to the tires themselves, as well as the vehicle's wheels and body.

■ If tire inflation pressure of each tire becomes low while driving (vehicles without run-flat tires)

Do not continue driving, or your tires and/or wheels may be ruined.

Tire rotation

Rotate the tires in the order shown.

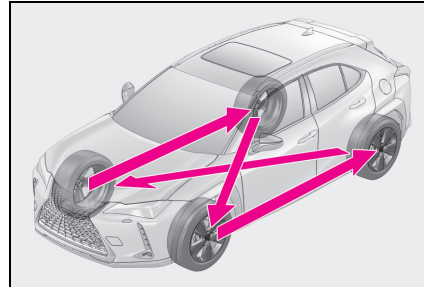

To equalize tire wear and help extend tire life, Lexus recommends that tire rotation is carried out approximately every 10000 km (6000 miles).

Do not fail to initialize the tire pressure warning system after tire rotation.

■ When rotating the tires

Make sure that the engine switch is OFF. If the tires are rotated while the engine switch is in ON, the tire position information will not be updated.

If this accidentally occurs, either turn the engine switch to OFF and then to ON, or initialize the tire pressure warning system

after checking that the tire pressure is properly adjusted.

Run-flat tires (if equipped)

When run-flat tires are installed, the vehicle can be driven for a maximum of 160 km (100 miles) at a speed below 80 km/h (50 mph) after any tire goes flat. (However, the vehicle speed may not increase to near 80 km/h [50 mph] depending on weather or driving conditions.)

A run-flat tire has a  mark on the sidewall.

Make sure to replace the flat tire before the vehicle has been driven for near 160 km (100 miles). Also, do not use a repaired tire.

Run-flat tires

- The run-flat tires are for only this vehicle. Do not use the tires on other vehicles.
- Do not mix run-flat tires and normal tires.
- If non-genuine Lexus wheels are used, it may be impossible to sufficiently demonstrate the performance of run-flat tires.

Tire pressure warning system

Your vehicle is equipped with a tire pressure warning system that uses tire pressure warning valves and transmitters to detect low tire inflation pressure before serious problems arise.

- If the tire pressure drops below a predetermined level, the driver is warned by a screen display and a warning light. (→P.445, 452)
- The tire pressure detected by the

tire pressure warning system can be displayed on the multi-information display. (→P.115)

The illustration used is intended as an example, and may differ from the image that is actually displayed on the multi-information display.



Routine tire inflation pressure checks

The tire pressure warning system does not replace routine tire inflation pressure checks. Make sure to check tire inflation pressure as part of your routine of daily vehicle checks.

Tire inflation pressure

- It may take a few minutes to display the tire inflation pressure after the engine switch is turned to ON. It may also take a few minutes to display the tire inflation pressure after inflation pressure has been adjusted.
- Tire inflation pressure changes with temperature. The displayed values may also be different from the values measured using a tire pressure gauge.

Situations in which the tire pressure warning system may not operate properly

- In the following cases, the tire pressure warning system may not operate properly.
 - If non-genuine Lexus wheels are used.
 - A tire has been replaced with a tire that is not an OE (Original Equipment) tire.
 - A tire has been replaced with a tire that is not of the specified size.

- Tire chains etc. are equipped.
- An auxiliary-supported run-flat tire is equipped.
- If a window tint that affects the radio wave signals is installed.
- If there is a lot of snow or ice on the vehicle, particularly around the wheels or wheel housings.
- If the tire inflation pressure is extremely higher than the specified level.
- If wheels without tire pressure warning valves and transmitters are used.
- If the ID code on the tire pressure warning valves and transmitters is not registered in the tire pressure warning computer.
- Performance may be affected in the following situations.
 - Near a TV tower, electric power plant, gas station, radio station, large display, airport or other facility that generates strong radio waves or electrical noise
 - When carrying a portable radio, cellular phone, cordless phone or other wireless communication device

If tire position information is not correctly displayed due to the radio wave conditions, the display may be corrected by driving and changing the radio wave conditions.

- When the vehicle is parked, the time taken for the warning to start or go off could be extended.
- When tire inflation pressure declines rapidly for example when a tire has burst, the warning may not function.

■ Warning performance of the tire pressure warning system

The warning of the tire pressure warning system will change in accordance with the conditions under which it was initialized. For this reason, the system may give a warning even if the tire pressure does not reach a low enough level, or if the pressure is higher than the pressure that was adjusted to when the system was initialized.

■ Certification for tire pressure warning system

• Manufacturer's name: PACIFIC INDUSTRIAL CO.,LTD.

• Registered trademark:



This trademark is registered in the following countries:
UK, Italy, Austria, Greece, Germany, France, Belgium,
the Netherlands, Luxembourg, Portugal.

• Manufacturer's address:

1300-1 Yokoi, Godo-cho, Anpachi-gun, Gifu, 503-2397 JAPAN

• Operating frequency band: 433.05 — 434.79MHz

• Maximum radio-frequency power: 100dBμV/m@3m(Radiated)

Hereby, PACIFIC INDUSTRIAL CO.,LTD. declares that the radio equipment type PMV-C215 is in compliance with Directive 2014/53/EU.

The full text of the EU declaration of conformity is available at the following internet address:

<http://www.pacific-ind.co.jp/eng/products/car/tpms/doc/>

PACIFIC INDUSTRIAL CO.,LTD. vakuuttaa, että radiolaitetyyppi PMV-C215 on direktiivin 2014/53/EU mukainen.

EU-vaatimustenmukaisuusvakuutuksen täysimittainen teksti on saatavilla seuraavassa internetosoitteessa:

<http://www.pacific-ind.co.jp/eng/products/car/tpms/doc/>

<p>Hierbij verklaar ik, PACIFIC INDUSTRIAL CO.,LTD., dat het type radioapparatuur PMV-C215 conform is met Richtlijn 2014/53/EU.</p> <p>De volledige tekst van de EU-conformiteitsverklaring kan worden geraadpleegd op het volgende internetadres: http://www.pacific-ind.co.jp/eng/products/car/tpms/doc/</p>
<p>Le soussigné, PACIFIC INDUSTRIAL CO.,LTD., déclare que l'équipement radioélectrique du type PMV-C215 est conforme à la directive 2014/53/UE.</p> <p>Le texte complet de la déclaration UE de conformité est disponible à l'adresse internet suivante: http://www.pacific-ind.co.jp/eng/products/car/tpms/doc/</p>
<p>Härmed försäkrar PACIFIC INDUSTRIAL CO.,LTD. att denna typ av radioutrustning PMV-C215 överensstämmer med direktiv 2014/53/EU.</p> <p>Den fullständiga texten till EU-försäkran om överensstämmelse finns på följande webbadress: http://www.pacific-ind.co.jp/eng/products/car/tpms/doc/</p>
<p>Hermed erklærer PACIFIC INDUSTRIAL CO.,LTD., at radioudstyrstypen PMV-C215 er i overensstemmelse med direktiv 2014/53/EU.</p> <p>EU-overensstemmelseserklæringens fulde tekst kan findes på følgende internetadresse: http://www.pacific-ind.co.jp/eng/products/car/tpms/doc/</p>
<p>Hiermit erklährt PACIFIC INDUSTRIAL CO.,LTD. , dass der Funkanlagentyp PMV-C215 der Richtlinie 2014/53/EU entspricht.</p> <p>Der vollständige Text der EU-Konformitätserklärung ist unter der folgenden Internetadresse verfügbar: http://www.pacific-ind.co.jp/eng/products/car/tpms/doc/</p>

Με την παρούσα ο/η PACIFIC INDUSTRIAL CO.,LTD., δηλώνει ότι ο ραδιοεξοπλισμός PMV-C215 πληροί την οδηγία 2014/53/ΕΕ. Το πλήρες κείμενο της δήλωσης συμμόρφωσης ΕΕ διατίθεται στην ακόλουθη ιστοσελίδα στο διαδίκτυο:

<http://www.pacific-ind.co.jp/eng/products/car/tpms/doc/>

Il fabbricante, PACIFIC INDUSTRIAL CO.,LTD. , dichiara che il tipo di apparecchiatura radio PMV-C215 è conforme alla direttiva 2014/53/UE.

Il testo completo della dichiarazione di conformità UE è disponibile al seguente indirizzo Internet:

<http://www.pacific-ind.co.jp/eng/products/car/tpms/doc/>

Por la presente, PACIFIC INDUSTRIAL CO.,LTD.declara que el tipo de equipo radioeléctrico PMV-C215 es conforme con la Directiva 2014/53/UE.

El texto completo de la declaración UE de conformidad está disponible en la dirección Internet siguiente:

<http://www.pacific-ind.co.jp/eng/products/car/tpms/doc/>

O(a) abaixo assinado(a) PACIFIC INDUSTRIAL CO.,LTD. declara que o presente tipo de equipamento de rádio PMV-C215 está em conformidade com a Diretiva 2014/53/UE.

O texto integral da declaração de conformidade está disponível no seguinte endereço de Internet:

<http://www.pacific-ind.co.jp/eng/products/car/tpms/doc/>

B'dan, PACIFIC INDUSTRIAL CO.,LTD., niddikjara li dan it-tip ta' tagħmir tar-radju PMV-C215 huwa konformi mad-Direttiva 2014/53/UE.

It-test kollu tad-dikjarazzjoni ta' konformità tal-UE huwa disponibbli f'dan l-indirizz tal-Internet li ġej:

<http://www.pacific-ind.co.jp/eng/products/car/tpms/doc/>

Käesolevaga deklareerib PACIFIC INDUSTRIAL CO.,LTD., et käesolev raadioseadme tüüp PMV-C215 vastab direktiivi 2014/53/EL nõuetele.

ELi vastavusdeklaratsiooni täielik tekst on kättesaadav järgmisel internetiaadressil:

<http://www.pacific-ind.co.jp/eng/products/car/tpms/doc/>

PACIFIC INDUSTRIAL CO.,LTD. igazolja, hogy a PMV-C215 típusú rádióberendezés megfelel a 2014/53/EU irányelvnek.

Az EU-megfelelőségi nyilatkozat teljes szövege elérhető a következő internetes címen:

<http://www.pacific-ind.co.jp/eng/products/car/tpms/doc/>

PACIFIC INDUSTRIAL CO.,LTD. týmto vyhlasuje, že rádiové zariadenie typu PMV-C215 je v súlade so smernicou 2014/53/EÚ.

Úplné EÚ vyhlásenie o zhode je k dispozícii na tejto internetovej adrese:

<http://www.pacific-ind.co.jp/eng/products/car/tpms/doc/>

Týmto PACIFIC INDUSTRIAL CO.,LTD. prohlašuje, že typ rádiového zařízení PMV-C215 je v souladu se směrnicí 2014/53/EU.

Úplné znění EU prohlášení o shodě je k dispozici na této internetové adrese:

<http://www.pacific-ind.co.jp/eng/products/car/tpms/doc/>

<p>PACIFIC INDUSTRIAL CO.,LTD. potrjuje, da je tip radijske opreme PMV-C215 skladen z Direktivo 2014/53/EU.</p> <p>Celotno besedilo izjave EU o skladnosti je na voljo na naslednjem spletnem naslovu: http://www.pacific-ind.co.jp/eng/products/car/tpms/doc/</p>
<p>Aš, PACIFIC INDUSTRIAL CO.,LTD. , patvirtinu, kad radijo i renginių tipas PMV-C215 atitinka Direktyvą 2014/53/ES. Visas ES atitikties deklaracijos tekstas prieinamas šiuo interneto adresu: http://www.pacific-ind.co.jp/eng/products/car/tpms/doc/</p>
<p>Ar šoPACIFIC INDUSTRIAL CO.,LTD. deklarē, ka radioiekārta PMV-C215 atbilst Direktīvai 2014/53/ES.</p> <p>Pilns ES atbilstības deklarācijas teksts ir pieejams šādā interneta vietnē: http://www.pacific-ind.co.jp/eng/products/car/tpms/doc/</p>
<p>PACIFIC INDUSTRIAL CO.,LTD. niniejszym oświadcza, że typ urządzenia radiowego PMV-C215 jest zgodny z dyrektywą 2014/53/UE.</p> <p>Pełny tekst deklaracji zgodności UE jest dostępny pod następującym adresem internetowym: http://www.pacific-ind.co.jp/eng/products/car/tpms/doc/</p>
<p>Hér með lýsir PACIFIC INDUSTRIAL CO.,LTD. yfir því að PMV-C215 er í samræmi við grunnkröfur og aðrar kröfur, sem gerðar eru í tilskipun 2014/53/EU.</p> <p>Samræmisýfirlýsing er einnig aðgengileg á eftirfarandi vefslóð: http://www.pacific-ind.co.jp/eng/products/car/tpms/doc/</p>

PACIFIC INDUSTRIAL CO.,LTD. erklærer at PMV-C215 er i overensstemmelse med direktiv 2014/53/EU.

Samsvarserklæringen i fulltekst er tilgjengelig på følgende internettadresse:

<http://www.pacific-ind.co.jp/eng/products/car/tpms/doc/>

С настоящото PACIFIC INDUSTRIAL CO.,LTD. декларира, че този тип радиосъоръжение PMV-C215 е в съответствие с Директива 2014/53/ЕС.

Цялостният текст на ЕС декларацията за съответствие може да се намери на следния интернет адрес:

<http://www.pacific-ind.co.jp/eng/products/car/tpms/doc/>

Prin prezenta, PACIFIC INDUSTRIAL CO.,LTD. declară că tipul de echipamente radio PMV-C215 este în conformitate cu Directiva 2014/53/UE.

Textul integral al declarației UE de conformitate este disponibil la următoarea adresă internet:

<http://www.pacific-ind.co.jp/eng/products/car/tpms/doc/>

Ovim, PACIFIC INDUSTRIAL CO.,LTD. , izjavljuje da ovaj PMV-C215 je usklađen sa bitnim zahtjevima i drugim relevantnim odredbama Direktive 1999/5/EC.

<http://www.pacific-ind.co.jp/eng/products/car/tpms/doc/>

Ovim, PACIFIC INDUSTRIAL CO.,LTD. , deklarirše da je PMV-C215 u skladu sa osnovnim zahtevima i ostalim relevantnim odredbama Direktive 1999/5/EC.

<http://www.pacific-ind.co.jp/eng/products/car/tpms/doc/>

PACIFIC INDUSTRIAL CO.,LTD. ovime izjavljuje da je radijska oprema tipa PMV-C215 u skladu s Direktivom 2014/53/EU.

Cjeloviti tekst EU izjave o sukladnosti dostupan je na sljedećoj internetskoj adresi:

<http://www.pacific-ind.co.jp/eng/products/car/tpms/doc/>

Nepermjet kesaj, PACIFIC INDUSTRIAL CO.,LTD. , deklaroi qe ky PMV-C215 eshte ne pajtim me kerkesat thelbesore dhe dispozitat e tjera perkatese te Direktives 1999/5/EC.

<http://www.pacific-ind.co.jp/eng/products/car/tpms/doc/>

Installing tire pressure warning valves and transmitters

When replacing tires or wheels, tire pressure warning valves and transmitters must also be installed.

When new tire pressure warning valves and transmitters are installed, new ID codes must be registered in the tire pressure warning computer and the tire pressure warning system must be initialized. (→P.422)

■ When replacing the tires and wheels

If the ID code of the tire pressure warning valve and transmitter is not registered, the tire pressure warning system will not work properly. After driving for about 10 minutes, the tire pressure warning light blinks for 1 minute and stays on to indicate a system malfunction.

NOTICE

■ Repairing or replacing tires, wheels, tire pressure warning valves, transmitters and tire valve caps

- When removing or fitting the wheels, tires or the tire pressure warning valves and transmitters, contact any authorized Lexus retailer or Lexus authorized repairer, or any reliable repairer as the tire pressure warning valves and transmitters may be damaged if not handled correctly.
- Make sure to install the tire valve caps. If the tire valve caps are not installed, water could enter the tire pressure warning valves and the tire pressure warning valves could be bound.
- When replacing tire valve caps, do not use tire valve caps other than those specified. The cap may become stuck.



NOTICE

■ **To avoid damage to the tire pressure warning valves and transmitters**

When a tire is repaired with liquid sealants, the tire pressure warning valve and transmitter may not operate properly. If a liquid sealant is used, contact any authorized Lexus retailer or Lexus authorized repairer, or any reliable repairer or other qualified service shop as soon as possible. After use of liquid sealant, make sure to replace the tire pressure warning valve and transmitter when repairing or replacing the tire.

Initializing the tire pressure warning system

■ **The tire pressure warning system must be initialized in the following circumstances:**

- When rotating the tires.
- When the tire inflation pressure is changed such as when changing tire size. (When there are multiple specified pressures)
- After registering the ID codes. (→P.422)

When the tire pressure warning system is initialized, the current tire inflation pressure is set as the benchmark pressure.

■ **How to initialize the tire pressure warning system**

- 1 Park the vehicle in a safe place and stop the engine for 20 minutes or more.

Initialization cannot be performed while the vehicle is moving.

- 2 Adjust the tire inflation pressure to the specified cold tire inflation pressure level.

Make sure to adjust the tire pressure to the specified cold tire inflation pressure level. The tire pressure warning system will operate based on this pressure level.

- 3 Turn the engine switch to ON. (→P.217)
- 4 Press **<** or **>** of the meter control switches and select .
- 5 Press **▲** or **▼** of the meter control switches and select "Vehicle Settings", and then press "OK".
- 6 Press **▲** or **▼** of the meter control switches and select "TPWS", and then press "OK".
- 7 Press **▲** or **▼** of the meter control switches and select "Set Pressure", and then press and hold "OK" until the tire pressure warning light starts blinking.

A message is displayed on the multi-information display. Also, "--" is displayed for inflation pressure of each tire on the multi-information display while the tire pressure warning system determines the position.

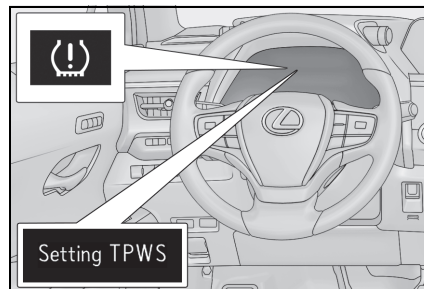

- 8 Drive at approximately 40 km/h (25 mph) or more for approximately 10 to 30 minutes.

When initialization is complete, the inflation pressure of each tire will be displayed on the multi-information display.

Even if the vehicle is not driven at approximately 40 km/h (25 mph) or more, initialization can be completed by driving for a long time. However, if initialization does not complete after driving for 1 hour or more, park the vehicle in a safe place for approximately 20 minutes and then drive the vehicle again.

■ When initializing

- Initialization is performed while driving at a vehicle speed of approximately 40 km/h (25 mph) or more.
- Make sure to carry out initialization after adjusting the tire inflation pressure. Also, make sure the tires are cold before carrying out initialization or tire inflation pressure adjustment.
- The tire pressure warning system can be initialized by yourself, but depending on the driving conditions and driving environment, initialization may take some time to complete.

■ The initialization operation

- If you have accidentally turned the engine switch off during initialization, it is not necessary to manually restart the initialization again, as initialization will restart automatically the next time the engine switch is turned to ON.
- If you accidentally perform initialization when initialization is not necessary, adjust the tire inflation pressure to the specified level when the tires are cold, and conduct initialization again.
- While the position of each tire is being determined and the inflation pressures are not being displayed on the multi-information display, if the inflation pressure of a tire drops, the tire pressure warning light will come on.

■ If the tire pressure warning system is not initialized properly

- In the following situations, initialization may take longer than usual to be completed or may not be possible. Normally, initialization completes within approximately 30 minutes.
 - Vehicle is not driven at approximately 40 km/h (25 mph) or more
 - Vehicle is driven on unpaved roads
 - Vehicle is driven near other vehicles and system cannot recognize tire pressure warning valve and transmitters of your vehicle over those of other vehicles

If initialization does not complete after driving for 1 hour or more, park the vehicle in a safe place for approximately 20 minutes and then drive the vehicle again.

- If the vehicle is reversed during initialization, the data up to that point is reset, so perform the initialization procedure again from the beginning.
- In the following situations, initialization will not be started or was not completed properly and the system will not operate properly. Perform the initialization procedure again.
 - If, when attempting to start initialization, the tire pressure warning light does not blink 3 times.
 - If, when the vehicle has been driven for about 20 minutes after performing initialization, the tire pressure warning light blinks for approximately 1 minute and then illuminates.

If the inflation pressure of each tire is still not displayed, have the vehicle inspected by any authorized Lexus retailer or Lexus authorized repairer, or any reliable repairer.

⚠ WARNING**■ When initializing the tire pressure warning system**

Do not initialize tire inflation pressure without first adjusting the tire inflation pressure to the specified level. Otherwise, the tire pressure warning light may not come on even if the tire inflation pressure is low, or it may come on when the tire inflation pressure is actually normal.

Registering ID codes

The tire pressure warning valve and transmitter is equipped with a unique ID code. When replacing a tire pressure warning valve and transmitter, it is necessary to register the ID code.

When registering the ID codes, perform the following procedure.

- 1 Park the vehicle in a safe place, wait for approximately 20 minutes, and then start the engine. (→P.217)
- 2 Press **<** or **>** of the meter control switches and select .
- 3 Press **▲** or **▼** of the meter control switches and select "Vehicle Settings", and then press "OK".
- 4 Press **▲** or **▼** of the meter control switches and select "TPWS", and then press "OK".
- 5 Press **▲** or **▼** of the meter control switches and select "Change Wheel Set", and then press and hold "OK" until the tire pressure warning light starts slowly blinking 3 times.

The change wheel set mode is activated and registration is started.

A message is displayed on the multi-information display, and "--" is displayed for inflation pressure of each tire. Then, the tire pressure warning light blinks rapidly for approximately 1 minute and stays on.

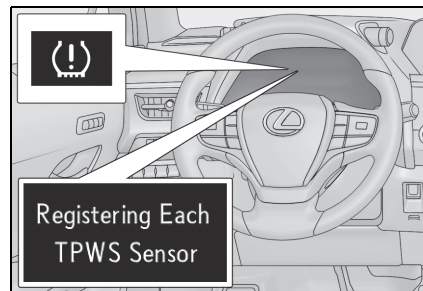

- 6 Drive at approximately 40 km/h (25 mph) or more for approximately 10 to 30 minutes.

Registration is complete when the tire pressure warning light turns off and the inflation pressure of each tire is displayed on the multi-information display.

Even if the vehicle is not driven at approximately 40 km/h (25 mph) or more, registration can be completed by driving for a long time. However, if registration does not complete after driving for 1 hour or more, perform the procedure again from the beginning.

- 7 Initialize the tire pressure warning system. (→P.420)

■ When registering ID codes

- ID code registration is performed while driving at a vehicle speed of approximately 40 km/h (25 mph) or more.
- Before performing ID code registration, make sure that no wheels with tire pressure warning valve and transmitters installed are near the vehicle.

- Make sure to initialize the tire pressure warning system after registering the ID codes. If the system is initialized before registering the ID codes, the initialized values will be invalid.
 - ID codes can be registered by yourself, but depending on the driving conditions and driving environment, registration may take some time to complete.
- **Canceling the change wheel set mode**
- If turning the engine switch off when in the change wheel set mode before driving, the change wheel set mode is canceled.
 - After driving when in the change wheel set mode, the change wheel set mode cannot be canceled. To cancel the mode, perform the procedure for ID code registration again and turn the engine switch off before driving.
 - If the change wheel set mode is canceled, the ID codes that have already been registered are communicated. When communication is finished, the tire pressure warning light will turn off.
- **If ID codes are not registered properly**
- In the following situations, ID code registration may take longer than usual to be completed or may not be possible. Normally, registration completes within approximately 30 minutes.
 - Vehicle is not parked for approximately 20 minutes or more before driving
 - Vehicle is not driven at approximately 40 km/h (25 mph) or more
 - Vehicle is driven on unpaved roads
 - Vehicle is driven near other vehicles and system cannot recognize tire pressure warning valves and transmitters of your vehicle over those of other vehicles
 - Wheel with tire pressure warning valve and transmitter installed is inside or near the vehicle
- If registration does not complete after driving for 1 hour or more, perform the ID code registration procedure again from the beginning.
- If the vehicle is reversed during registration, the data up to that point is reset, so perform the registration procedure again from the beginning.
 - In the following situations, ID code registration will not be started or was not completed properly and the system will not operate properly. Perform the ID code registration procedure again.
 - If, when attempting to start ID code registration, the tire pressure warning light does not blink slowly 3 times.
 - If, when the vehicle has been driven for about 20 minutes after performing ID code registration, the tire pressure warning light blinks for approximately 1 minute and then illuminates.
 - If ID code registration cannot be completed after performing the above procedure, contact any authorized Lexus retailer or Lexus authorized repairer, or any reliable repairer.

Tire inflation pressure

Make sure to maintain proper tire inflation pressure. Tire inflation pressure should be checked at least once per month. However, Lexus recommends that tire inflation pressure be checked once every two weeks.

■ Effects of incorrect tire inflation pressure

Driving with incorrect tire inflation pressure may result in the following:

- Reduced fuel economy
- Reduced driving comfort and poor handling
- Reduced tire life due to wear
- Reduced safety
- Damage to the drive train

If a tire needs frequent inflating, have it checked by any authorized Lexus retailer or Lexus authorized repairer, or any reliable repairer.

■ Instructions for checking tire inflation pressure

When checking tire inflation pressure, observe the following:

- Check only when the tires are cold. If your vehicle has been parked for at least 3 hours or has not been driven for more than 1.5 km or 1 mile, you will get an accurate cold tire inflation pressure reading.
- Always use a tire pressure gauge. It is difficult to judge if a tire is properly inflated based only on its appearance.
- It is normal for the tire inflation pressure to be higher after driving as heat is generated in the tire. Do not reduce tire inflation pressure after driving.
- Passengers and luggage weight should be placed so that the vehicle is balanced.

WARNING

■ Proper inflation is critical to save tire performance

Keep your tires properly inflated. If the tires are not properly inflated, the following conditions may occur which could lead to an accident resulting in death or serious injury:

- Excessive wear
- Uneven wear
- Poor handling
- Possibility of blowouts resulting from overheated tires
- Air leaking from between tire and wheel
- Wheel deformation and/or tire damage
- Greater possibility of tire damage while driving (due to road hazards, expansion joints, sharp edges in the road, etc.)

NOTICE

■ When inspecting and adjusting tire inflation pressure

Be sure to put the tire valve caps back on. If a valve cap is not installed, dirt or moisture may get into the valve and cause an air leak, resulting in decreased tire inflation pressure.

Wheels

If a wheel is bent, cracked or heavily corroded, it should be replaced. Otherwise, the tire may separate from the wheel or cause a loss of handling control.

Wheel selection

When replacing wheels, care should be taken to ensure that they are equivalent to those removed in load capacity, diameter, rim width and inset*. Replacement wheels are available at any authorized Lexus retailer or Lexus authorized repairer, or any reliable repairer.

*: Conventionally referred to as offset.

Lexus does not recommend using the following:

- Wheels of different sizes or types
- Used wheels
- Bent wheels that have been straightened

■ When replacing wheels

The wheels of your vehicle are equipped with tire pressure warning valves and transmitters that allow the tire pressure warning system to provide advance warning in the event of a loss in tire inflation pressure. Whenever wheels are replaced, tire pressure warning valves and transmitters must be installed. (→P.419)

⚠ WARNING

■ When replacing wheels

- Do not use wheels that are a different size from those recommended in the Owner's Manual, as this may result in a loss of handling control.
- Never use an inner tube in a leaking wheel which is designed for a tubeless tire. Doing so may result in an accident, causing death or serious injury.

■ Use of defective wheels prohibited

Do not use cracked or deformed wheels. Doing so could cause the tire to leak air during driving, possibly causing an accident.

⚠ NOTICE

■ Replacing tire pressure warning valves and transmitters

- Because tire repair or replacement may affect the tire pressure warning valves and transmitters, make sure to have tires serviced by any authorized Lexus retailer or Lexus authorized repairer, or any reliable repairer or other qualified service shop. In addition, make sure to purchase your tire pressure warning valves and transmitters at any authorized Lexus retailer or Lexus authorized repairer, or any reliable repairer.
- Ensure that only genuine Lexus wheels are used on your vehicle. Tire pressure warning valves and transmitters may not work properly with non-genuine wheels.

Aluminum wheel precautions

- Use only Lexus wheel nuts and wrenches designed for use with your aluminum wheels.
- When rotating, repairing or chang-

ing your tires, check that the wheel nuts are still tight after driving 1600 km (1000 miles).

- Be careful not to damage the aluminum wheels when using tire chains.
- Use only Lexus genuine balance weights or equivalent and a plastic or rubber hammer when balancing your wheels.

Air conditioning filter

The air conditioning filter must be changed regularly to maintain air conditioning efficiency.

Removing the air conditioning filter

- 1 Turn the engine switch off.
- 2 Open the glove box. Remove the partition. (→P.373)
- 3 Remove the panel.

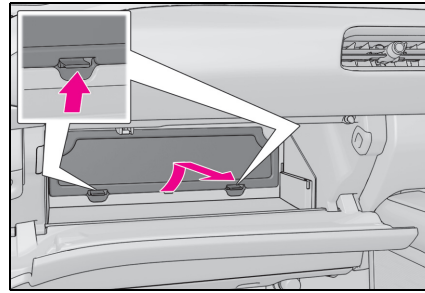

- 4 Unlock the filter cover (A), pull the filter cover out of the claws (B), and remove the filter cover.

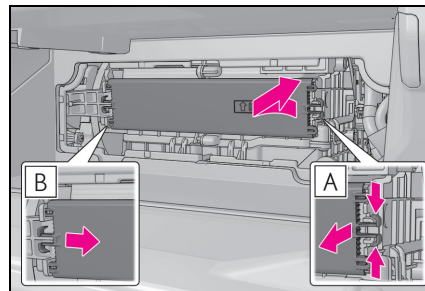

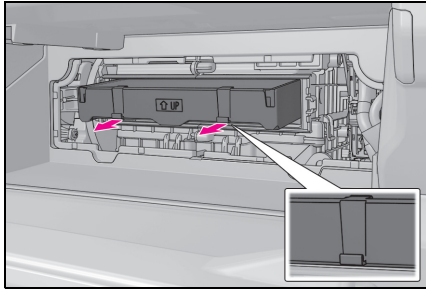
5 Remove the filter case.**6** Remove the air conditioning filter from the filter case and replace it with a new one.

The “↑ UP” marks shown on the filter and the filter case should be pointing up.

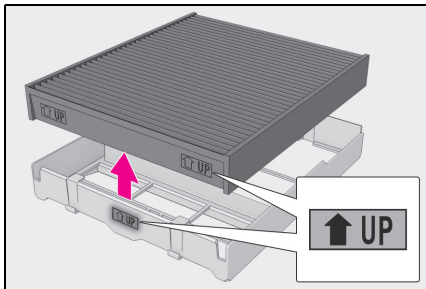
**■ Checking interval**

Inspect and replace the air conditioning filter according to the maintenance schedule. In dusty areas or areas with heavy traffic flow, early replacement may be required. (Except for India: For scheduled maintenance information, please refer to the “Lexus Service Booklet” or “Lexus Warranty Booklet”.)

■ If air flow from the vents decreases dramatically

The filter may be clogged. Check the filter and replace if necessary.

■ Air conditioning filter with deodorizing function

When fragrances are placed in your vehicle, the deodorizing effect may become

significantly weakened in a short period. When an air conditioning odor comes out continuously, replace the air conditioning filter.

⚠ NOTICE**■ When using the air conditioning system**

Make sure that a filter is always installed. Using the air conditioning system without a filter may cause damage to the system.

■ To prevent damage to the filter cover

When moving the filter cover in the direction of arrow to release the fitting, pay attention not to apply excessive force to the claws. Otherwise, the claws may be damaged.

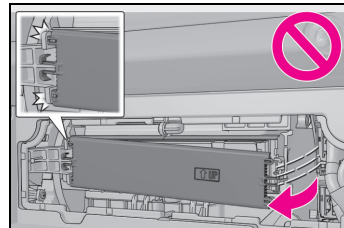

Electronic key battery

Replace the battery with a new one if it is depleted.

■ If the electronic key battery is depleted

The following symptoms may occur:

- The smart entry & start system and wireless remote control will not function properly.
- The operational range will be reduced.

■ When the card key battery needs to be replaced (if equipped)

The battery for the card key is available only at any authorized Lexus retailer or Lexus authorized repairer, or any reliable repairer. Your authorized Lexus retailer or Lexus authorized repairer, or any reliable repairer can replace the battery for you.

Items to prepare

Prepare the following before replacing the battery:

- Flathead screwdriver
- Small flathead screwdriver
- Lithium battery CR2032

■ Use a CR2032 lithium battery

- Batteries can be purchased at any authorized Lexus retailer or Lexus authorized repairer, or any reliable repairer, local electrical appliance shops or camera stores.
- Replace only with the same or equivalent type recommended by the manufacturer.
- Dispose of used batteries according to the local laws.

Replacing the battery

- 1 Take out the mechanical key.

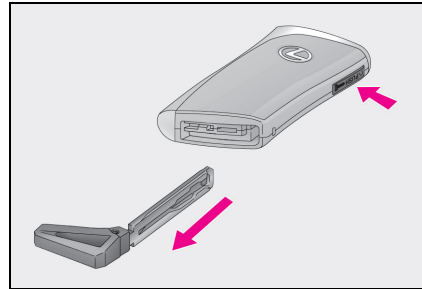

- 2 Remove the cover.

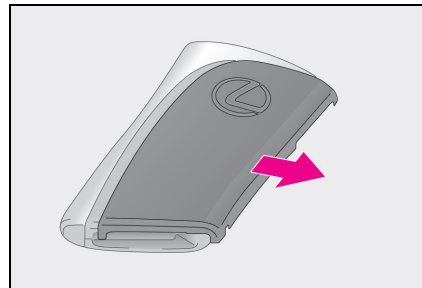

- 3 Remove the battery cover.

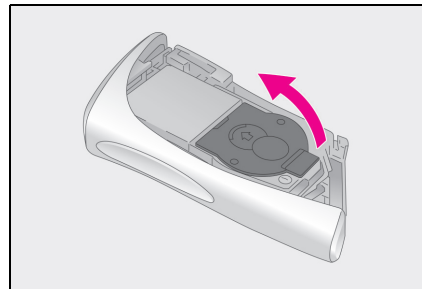

- 4 Remove the depleted battery using the small flathead screwdriver.

Insert a new battery with the "+" terminal

facing up.

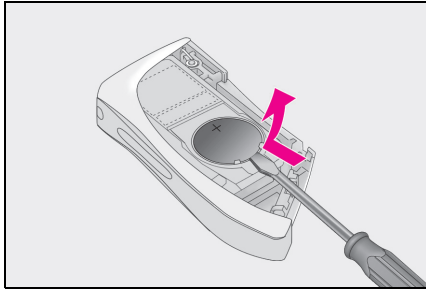

● Do not bend either of the battery terminals.

⚠ WARNING

■ **Removed battery and other parts**

These parts are small and if swallowed by a child, they can cause choking. Keep away from children. Failure to do so could result in death or serious injury.

■ **Certification for the electronic key battery**

CAUTION
RISK OF EXPLOSION IF BATTERY IS REPLACED BY AN INCORRECT TYPE.
DISPOSE OF USED BATTERIES ACCORDING TO THE INSTRUCTIONS.

⚠ NOTICE

■ **When replacing the battery**

Use a screwdriver of appropriate size. Applying excessive force may deform or damage the cover.

■ **For normal operation after replacing the battery**

Observe the following precautions to prevent accidents:

- Always work with dry hands. Moisture may cause the battery to rust.
- Do not touch or move any other component inside the remote control.

Checking and replacing fuses

If any of the electrical components do not operate, a fuse may have blown. If this happens, check and replace the fuses as necessary.

Checking and replacing fuses

- 1 Turn the engine switch off.
- 2 Open the fuse box cover.
 - ▶ Engine compartment: type A fuse box

Push the tab in and lift the lid off.

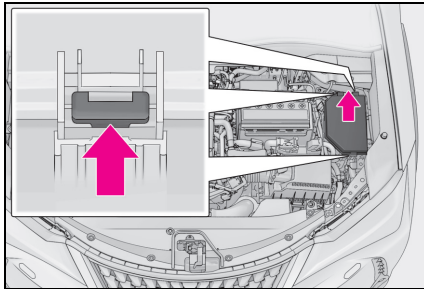

- ▶ Engine compartment: type B fuse box

Push the tab in and lift the lid off.

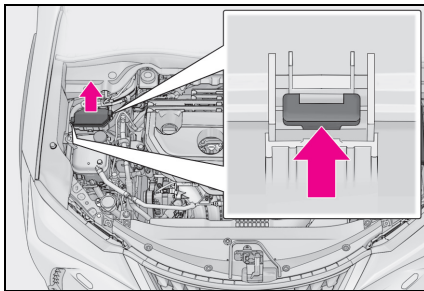

- ▶ Left side instrument panel (left-hand drive vehicles)

Remove the lid.

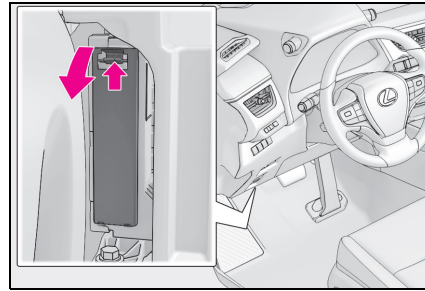

- ▶ Left side instrument panel (right-hand drive vehicles)

Remove the cover **A** and then remove the connector **B**.

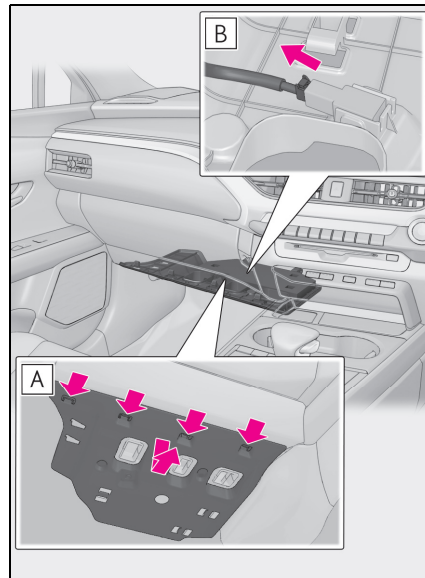

Remove the lid.

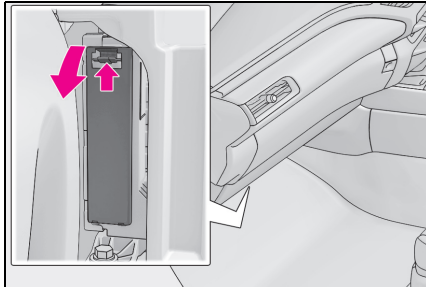

3 Remove the fuse.

Only type A fuse can be removed using the pullout tool.

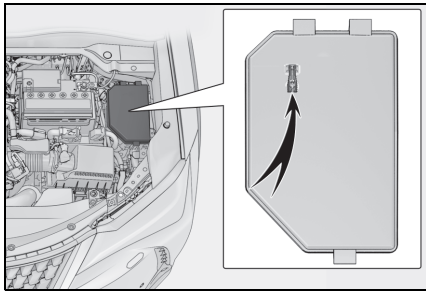

4 Check if the fuse is blown.

Replace the blown fuse with a new fuse of an appropriate amperage rating. The amperage rating can be found on the fuse box lid.

► Type A

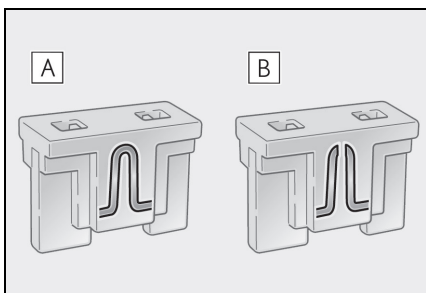

A Normal fuse

B Blown fuse

► Type B

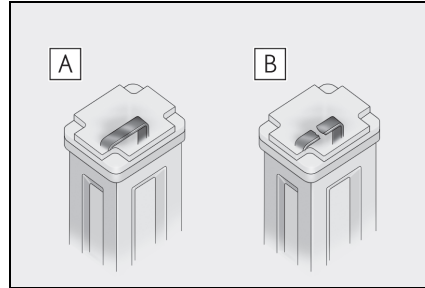

A Normal fuse

B Blown fuse

► Type C

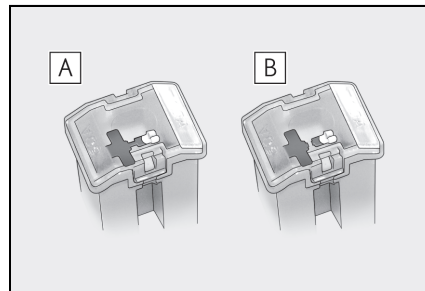

A Normal fuse

B Blown fuse

► Type D

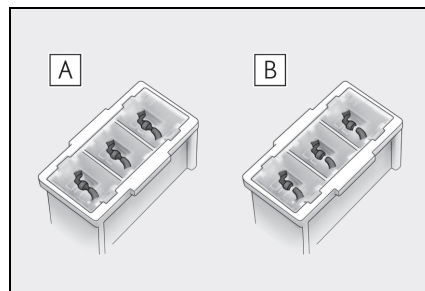

A Normal fuse

B Blown fuse

■ **After a fuse is replaced**

- When installing the lid, make sure that the tab is installed securely.
- If the lights do not turn on even after the fuse has been replaced, a bulb may need replacement.
- If the replaced fuse blows again, have the vehicle inspected by any authorized Lexus retailer or Lexus authorized repairer, or any reliable repairer.

■ **If there is an overload in a circuit**

The fuses are designed to blow, protecting the wiring harness from damage.

■ **When replacing light bulbs**

Lexus recommends that you use genuine Lexus products designed for this vehicle. Because certain bulbs are connected to circuits designed to prevent overload, non-genuine parts or parts not designed for this vehicle may be unusable.

⚠ WARNING

■ **To prevent system breakdowns and vehicle fire**

Observe the following precautions. Failure to do so may cause damage to the vehicle, and possibly a fire or injury.

- Never use a fuse of a higher amperage rating than that indicated, or use any other object in place of a fuse.
- Always use a genuine Lexus fuse or equivalent. Never replace a fuse with a wire, even as a temporary fix.
- Do not modify the fuses or fuse boxes.

⚠ NOTICE

■ **Before replacing fuses**

Have the cause of electrical overload determined and repaired by any authorized Lexus retailer or Lexus authorized repairer, or any reliable repairer as soon as possible.

Light bulbs

You may replace the following bulbs by yourself. Before replacing, check the wattage of the light bulb to be replaced. As there is a danger that components may be damaged, we recommend that replacement is carried out by any authorized Lexus retailer or Lexus authorized repairer, or any reliable repairer.

Bulb location

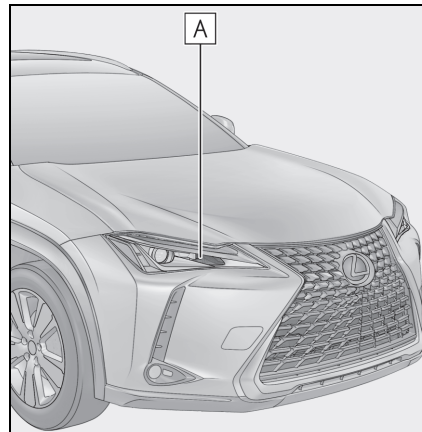

A Front turn signal light (vehicles with single-beam headlights)

■ **Bulbs that need to be replaced by any authorized Lexus retailer or Lexus authorized repairer, or any reliable repairer**

- Headlights
- Front position lights and daytime running lights
- Front turn signal lights (vehicles with

triple-beam headlights)

- Front fog lights (if equipped)
- Cornering lights (if equipped)
- Side turn signal lights
- Tail lights
- Stop lights
- Tail lights/stop lights
- Rear turn signal lights
- Rear fog lights
- Back-up lights
- High mounted stoplight
- License plate lights

■ LED lights

Vehicles with single-beam headlights:

The lights other than the front turn signal light each consist of a number of LEDs. If any of the LEDs burn out, take your vehicle to any authorized Lexus retailer or Lexus authorized repairer, or any reliable repairer to have the light replaced.

Vehicles with triple-beam headlights: The lights consist of a number of LEDs. If any of the LEDs burn out, take your vehicle to any authorized Lexus retailer or Lexus authorized repairer, or any reliable repairer to have the light replaced.

■ Condensation build-up on the inside of the lens

Temporary condensation build-up on the inside of the headlight lens does not indicate a malfunction. Contact any authorized Lexus retailer or Lexus authorized repairer, or any reliable repairer for more information in the following situations:

- Large drops of water have built up on the inside of the lens.
- Water has built up inside the headlight.

■ When replacing light bulbs

→P.432

Replacing light bulb

■ Front turn signal lights (vehicles with single-beam headlights)

- 1 Turn the bulb base counterclockwise.

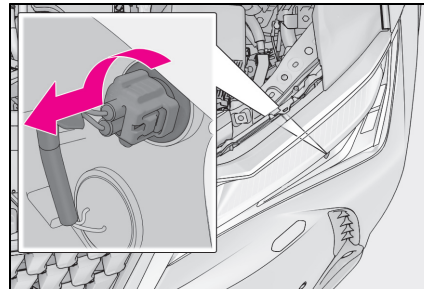

- 2 Remove the light bulb.

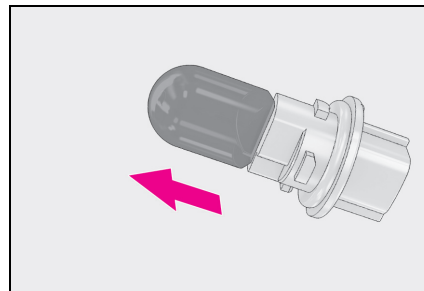

- 3 When installing, reverse the steps listed.

⚠ WARNING

■ Replacing light bulb

- Turn off the light. Do not attempt to replace the bulb immediately after turning off the light. The bulb become very hot and may cause burns.



WARNING

- Do not touch the glass portion of the light bulb with bare hands. When it is unavoidable to hold the glass portion, use and hold with a clean dry cloth to avoid getting moisture and oils on the bulb.
Also, if the bulb is scratched or dropped, it may blow out or crack.
- Fully install light bulb and any parts used to secure it. Failure to do so may result in heat damage, fire, or water entering the light unit. This may damage the light or cause condensation to build up on the lens.
- **To prevent damage or fire**
- Make sure bulb is fully seated and locked.
- Check the wattage of the bulb before installing to prevent heat damage.

When trouble arises

7

7-1. Essential information

Emergency flashers 436

If your vehicle has to be stopped in
an emergency..... 436

If the vehicle is trapped in rising
water..... 437

7-2. Steps to take in an emergency

If your vehicle needs to be towed
..... 439

If you think something is wrong
..... 442

Fuel pump shut off system 443

If a warning light turns on or a
warning buzzer sounds 444

If a warning message is displayed
..... 452

If you have a flat tire (vehicles with
emergency tire puncture repair
kit)..... 455

If you have a flat tire (vehicles with
spare tire) 467

If you have a flat tire (vehicles with
run-flat tires)..... 476

If the engine will not start 477

If you lose your keys 479

If the fuel filler door cannot be
opened 479

If the electronic key does not
operate properly 480

If the vehicle battery is discharged
..... 482

If your vehicle overheats 485

If the vehicle becomes stuck 487

Emergency flashers

The emergency flashers are used to warn other drivers when the vehicle has to be stopped in the road due to a breakdown, etc.

Operating instructions

Press the switch.

All the turn signal lights will flash. To turn them off, press the switch once again.

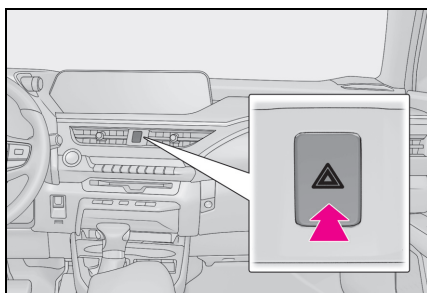

Emergency flashers

- If the emergency flashers are used for a long time while the engine is not running, the battery may discharge.
- If any of the SRS airbags deploy (inflate) or in the event of a strong rear impact, the emergency flashers will turn on automatically. The emergency flashers will turn off automatically after operating for approximately 20 minutes. To manually turn the emergency flashers off, press the switch twice. (The emergency flashers may not turn on automatically depending on the force of the impact and conditions of the collision.)

If your vehicle has to be stopped in an emergency

Only in an emergency, such as if it becomes impossible to stop the vehicle in the normal way, stop the vehicle using the following procedure:

Stopping the vehicle

- 1 Steadily step on the brake pedal with both feet and firmly depress it.

Do not pump the brake pedal repeatedly as this will increase the effort required to slow the vehicle.

- 2 Shift the shift lever to N.
 - ▶ If the shift lever is shifted to N
- 3 After slowing down, stop the vehicle in a safe place by the road.
- 4 Stop the engine.
 - ▶ If the shift lever cannot be shifted to N
- 3 Keep depressing the brake pedal with both feet to reduce vehicle speed as much as possible.
- 4 To stop the engine, press and hold the engine switch for 2 consecutive

seconds or more, or press it briefly 3 times or more in succession.

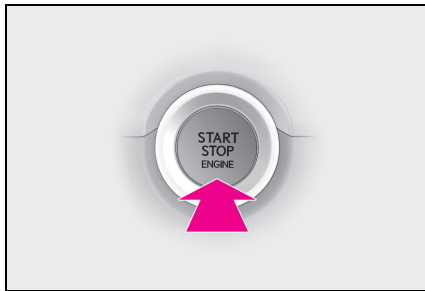

- 5 Stop the vehicle in a safe place by the road.

⚠ WARNING

■ **If the engine has to be turned off while driving**

Power assist for the steering wheel will be lost, making the steering wheel heavier to turn. Decelerate as much as possible before turning off the engine.

If the vehicle is trapped in rising water

In the event the vehicle is submerged in water, remain calm and perform the following.

- Remove the seat belt first.
- If the door can be opened, open the door and exit the vehicle.
- If the door can not be opened, open the window using the power window switch and exit the vehicle through the window.
- If the window can not be opened using the power window switch, remain calm, wait until the water level inside the vehicle rises to the point that the water pressure inside of the vehicle equals the water pressure outside of the vehicle, and then open the door and exit the vehicle.

⚠ WARNING

■ **Using an emergency hammer ^{*1} for emergency escape**

The rear side windows and rear window of this vehicle can be shattered by an emergency hammer ^{*1} used for emergency escape, however, since the windshield and front side windows ^{*2} are laminated glass they can not be shattered by an emergency hammer ^{*1}.

^{*1}: Contact any authorized Lexus retailer or Lexus authorized repairer, or any reliable repairer, or aftermarket accessory manufacturer for further information about an emergency hammer.

^{*2}: Vehicles with laminated glass

■ **Escaping the vehicle from the window**

There are cases where escaping the vehicle from the window is not possible due to seating position, passenger body type, etc.

When using an emergency hammer, consider your seat location and the size of the window opening to ensure that the opening is accessible and large enough to escape.

■ **How to distinguish laminated glass**

When looking from the cross-sectional view point, laminated glass is two sheets of glass pasted together.

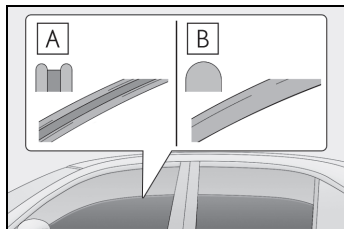

A Laminated glass

B Tempered glass

If your vehicle needs to be towed

If towing is necessary, we recommend having your vehicle towed by any authorized Lexus retailer or Lexus authorized repairer, or any reliable repairer or commercial towing service, using a wheel-lift type truck or flatbed truck.

Use a safety chain system for all towing, and abide by all state/provincial and local laws.

WARNING

Observe the following precautions. Failure to do so may result in death or serious injury.

■ When towing the vehicle

Be sure to transport the vehicle with the front wheels raised or with all four wheels raised off the ground. If the vehicle is towed with the front wheels contacting the ground, the drivetrain and related parts may be damaged.

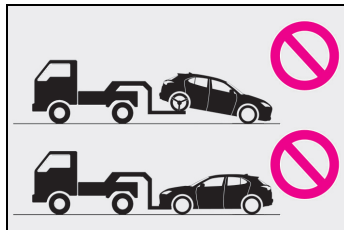

■ While towing

- When towing using cables or chains, avoid sudden starts, etc., which place excessive stress on the towing eyelets, cables or chains. The towing eyelets, cables or chains may become damaged, broken debris may hit people, and cause serious damage.

- Do not turn the engine switch off. There is a possibility that the steering wheel is locked and cannot be operated.

■ Installing towing eyelet to the vehicle

Make sure that towing eyelet is installed securely. If not securely installed, towing eyelet may come loose during towing.

NOTICE

■ To prevent damage to the vehicle when towing using a wheel-lift type truck

- Do not tow the vehicle from the rear when the engine switch is OFF. The steering lock mechanism is not strong enough to hold the front wheels straight.

- When raising the vehicle, ensure adequate ground clearance for towing at the opposite end of the raised vehicle. Without adequate clearance, the vehicle could be damaged while being towed.

■ To prevent damage to the vehicle when towing with a sling-type truck

Do not tow with a sling-type truck, either from the front or rear.

■ To prevent damage to the vehicle during emergency towing

Do not secure cables or chains to the suspension components.

■ Towing vehicles with Stop & Start system

If it is necessary to tow the vehicle with all 4 tires in contact with the ground, temporarily turn the engine switch OFF before towing to protect the system. After towing, start the engine or turn the switch to ON.

Situations when it is necessary to contact dealers before towing

The following may indicate a problem with your transmission. Contact any authorized Lexus retailer or Lexus authorized repairer, or any reliable repairer or commercial towing service before towing.

- The engine is running but the vehicle does not move.
- The vehicle makes an abnormal sound.

Towing with a sling-type truck

Do not tow with a sling-type truck to prevent body damage.

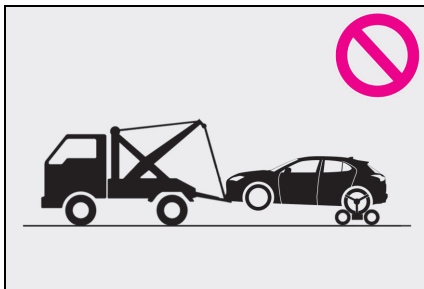

Towing with a wheel-lift type truck

- ▶ From the front
- Release the parking brake.

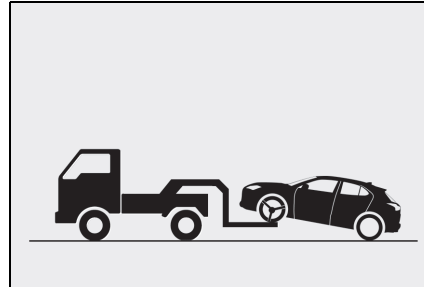

- ▶ From the rear
- Use a towing dolly under the front wheels.

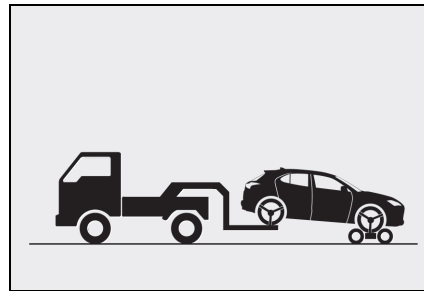

Using a flatbed truck

If your vehicle is transported by a flatbed truck, it should be tied down at the locations shown in the illustration.

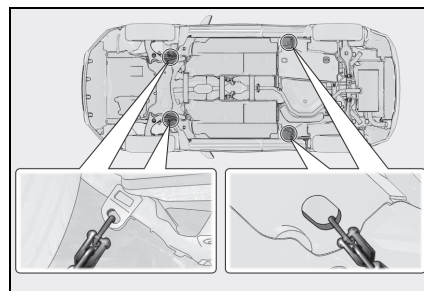

If you use chains or cables to tie down your vehicle, the angles shaded in black must be 45°.

Do not overly tighten the tie downs or

the vehicle may be damaged.

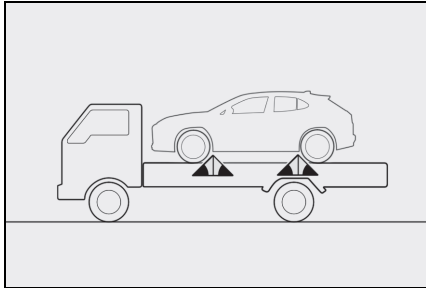

Emergency towing

If a tow truck is not available in an emergency, your vehicle may be temporarily towed using cables or chains secured to the emergency towing eyelets. This should only be attempted on hard surfaced roads for at most 80 km (50 miles) at under 30 km/h (18 mph).

A driver must be in the vehicle to steer and operate the brakes. The vehicle's wheels, drivetrain, axles, steering and brakes must be in good condition.

Emergency towing procedure

To have your vehicle towed by another vehicle, the towing eyelet must be installed to your vehicle. Install the towing eyelet by following the specified procedure.

- 1 Take out the towing eyelet. (→P.375)
- 2 Remove the eyelet cover using a flathead screwdriver.

To protect the bodywork, place a rag between the screwdriver and the vehicle

body as shown in the illustration.

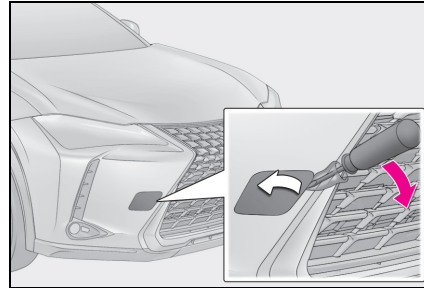

- 3 Insert the towing eyelet into the hole and tighten partially by hand.

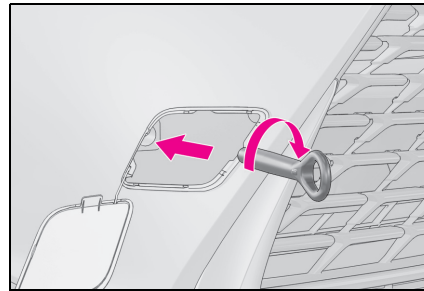

- 4 Tighten down the towing eyelet securely using a wheel nut wrench* or hard metal bar.

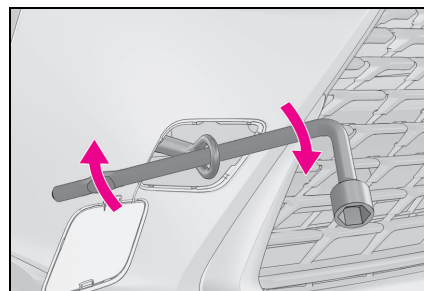

* If a wheel nut wrench is not equipped, a wheel nut wrench can be purchased at any authorized Lexus retailer or Lexus authorized repairer, or any reliable repairer.

- 5 Securely attach cables or chains to the towing eyelet.

Take care not to damage the vehicle body.

- 6 Enter the vehicle being towed and start the engine.

If the engine does not start, turn the engine switch to ON.

- 7 Shift the shift lever to N and release the parking brake.

When the shift lever cannot be shifted:
→P.222

■ While towing

If the engine is not running, the power assist for the brakes and steering will not function, making steering and braking more difficult.

■ Wheel nut wrench

Vehicles without wheel nut wrench: Wheel nut wrench can be purchased at any authorized Lexus retailer or Lexus authorized repairer, or any reliable repairer. Vehicles with wheel nut wrench:

Wheel nut wrench is installed in luggage compartment. (→P.375)

If you think something is wrong

If you notice any of the following symptoms, your vehicle probably needs adjustment or repair. Contact any authorized Lexus retailer or Lexus authorized repairer, or any reliable repairer as soon as possible.

Visible symptoms

- Fluid leaks under the vehicle (Water dripping from the air conditioning after use is normal.)
- Flat-looking tires or uneven tire wear
- Engine coolant temperature gauge needle continually points higher than normal

Audible symptoms

- Changes in exhaust sound
- Excessive tire squeal when cornering
- Strange noises related to the suspension system
- Pinging or other noises related to the engine

Operational symptoms

- Engine missing, stumbling or running roughly
- Appreciable loss of power

- Vehicle pulls heavily to one side when braking
- Vehicle pulls heavily to one side when driving on a level road
- Loss of brake effectiveness, spongy feeling, pedal almost touches the floor

Fuel pump shut off system

To minimize the risk of fuel leakage when the engine stalls or when an airbag inflates upon collision, the fuel pump shut off system stops the supply of fuel to the engine.

Restarting the engine

Follow the procedure below to restart the engine after the system is activated.

- 1 Turn the engine switch to ACC or turn it off.
- 2 Restart the engine.



NOTICE

■ Before starting the engine

Inspect the ground under the vehicle. If you find that fuel has leaked onto the ground, the fuel system has been damaged and is in need of repair. Do not restart the engine.

If a warning light turns on or a warning buzzer sounds

Calmly perform the following actions if any of the warning lights comes on or flashes. If a light comes on or flashes, but then goes off, this does not necessarily indicate a malfunction in the system. However, if this continues to occur, have the vehicle inspected by any authorized Lexus retailer or Lexus authorized repairer, or any reliable repairer.

Actions to the warning lights or warning buzzers

■ **Brake system warning light (warning buzzer)**

Warning light	Details/Actions
 <p>(red)</p>	<p>Indicates that:</p> <ul style="list-style-type: none"> ● The brake fluid level is low; or ● The brake system is malfunctioning <p>→ Immediately stop the vehicle in a safe place and contact any authorized Lexus retailer or Lexus authorized repairer, or any reliable repairer. Continuing to drive the vehicle may be dangerous.</p>

■ **Charging system warning light* (warning buzzer)**

Warning light	Details/Actions
	<p>Indicates a malfunction in the vehicle's charging system</p> <p>→ Immediately stop the vehicle in a safe place and contact any authorized Lexus retailer or Lexus authorized repairer, or any reliable repairer.</p>

*: This light illuminates on the multi-information display.

■ **Low engine oil pressure warning light* (warning buzzer)**

Warning light	Details/Actions
	<p>Indicates that the engine oil pressure is too low</p> <p>→ Immediately stop the vehicle in a safe place and contact any authorized Lexus retailer or Lexus authorized repairer, or any reliable repairer.</p>

*: This light illuminates on the multi-information display.

■ Malfunction indicator lamp (warning buzzer)

Warning light	Details/Actions
	<p>Indicates a malfunction in:</p> <ul style="list-style-type: none"> ● The emission control system (on some models); ● The electronic engine control system; ● The electronic throttle control system; or ● The electronic automatic transmission control system <p>→ Immediately stop the vehicle in a safe place and contact any authorized Lexus retailer or Lexus authorized repairer, or any reliable repairer.</p>

■ High coolant temperature warning light* (warning buzzer)

Warning light	Details/Actions
	<p>Indicates that the engine coolant temperature is too high</p> <p>→ Immediately stop the vehicle in a safe place.</p> <p>Handling method (→P.485)</p>

* : This light illuminates on the multi-information display.

■ Tire pressure warning light

Warning light	Details/Actions
	<p>When the light comes on after blinking for approximately 1 minute: Malfunction in the tire pressure warning system → Have the system checked by any authorized Lexus retailer or Lexus authorized repairer, or any reliable repairer.</p> <p>When the light comes on: Low tire inflation pressure such as</p> <ul style="list-style-type: none"> ● Natural causes ● Flat tire <p>Vehicles without run-flat tires → Immediately stop the vehicle in a safe place. (→P.450)</p> <p>Vehicles with run-flat tires → P.450</p>

■ Brake system warning light (warning buzzer)

Warning light	Details/Actions
 <p>(yellow)</p>	<p>Indicates a malfunction in the parking brake system</p> <p>→ Have the vehicle inspected by any authorized Lexus retailer or Lexus authorized repairer, or any reliable repairer immediately.</p>



■ SRS warning light (warning buzzer)

Warning light	Details/Actions
	<p>Indicates a malfunction in:</p> <ul style="list-style-type: none"> ● The SRS airbag system; or ● The seat belt pretensioner system <p>→ Have the vehicle inspected by any authorized Lexus retailer or Lexus authorized repairer, or any reliable repairer immediately.</p>

■ ABS warning light (warning buzzer)

Warning light	Details/Actions
	<p>Indicates a malfunction in:</p> <ul style="list-style-type: none"> ● The ABS; or ● The brake assist system <p>→ Have the vehicle inspected by any authorized Lexus retailer or Lexus authorized repairer, or any reliable repairer immediately.</p>

■ Electric power steering system warning light (warning buzzer)

Warning light	Details/Actions
 <p>(red)</p> <p>or</p>  <p>(yellow)</p>	<p>Indicates a malfunction in the EPS (Electric Power Steering) system</p> <p>→ Have the vehicle inspected by any authorized Lexus retailer or Lexus authorized repairer, or any reliable repairer immediately.</p>

■ Stop & Start cancel indicator (warning buzzer)

Warning light	Details/Actions
 <p>(flashes)</p>	<p>Indicates a malfunction in the Stop & Start system</p> <p>→ Have the vehicle inspected by any authorized Lexus retailer or Lexus authorized repairer, or any reliable repairer immediately.</p>

■ Slip indicator

Warning light	Details/Actions
	Indicates a malfunction in: <ul style="list-style-type: none"> ● The VSC system; ● The TRC system; or ● The hill-start assist control system → Have the vehicle inspected by any authorized Lexus retailer or Lexus authorized repairer, or any reliable repairer immediately.

■ Parking brake indicator

Warning light	Details/Actions
 (flashes)	Indicates a malfunction in the parking brake system → Have the vehicle inspected by any authorized Lexus retailer or Lexus authorized repairer, or any reliable repairer immediately.

■ Brake hold operated indicator (warning buzzer)

Warning light	Details/Actions
 (flashes)	Indicates a malfunction in the brake hold system → Have the vehicle inspected by any authorized Lexus retailer or Lexus authorized repairer, or any reliable repairer immediately.

■ Lexus parking assist-sensor OFF indicator (warning buzzer)

Warning light	Details/Actions
 (flashes) (if equipped)	When a buzzer sounds: Indicates a malfunction in the Lexus parking assist-sensor function → Have the vehicle inspected by any authorized Lexus retailer or Lexus authorized repairer, or any reliable repairer immediately. When a buzzer does not sound: Indicates that the system is temporarily unavailable, possibly due to a sensor being dirty or covered with ice, etc. → Follow the instructions displayed on the multi-information display. (→P.316)

■ RCTA OFF indicator (warning buzzer)

Warning light	Details/Actions
 (flashes) (if equipped)	Indicates a malfunction in the RCTA (Rear Crossing Traffic Alert) function → Have the vehicle inspected by any authorized Lexus retailer or Lexus authorized repairer, or any reliable repairer immediately.

■ PKSB OFF indicator (warning buzzer)

Warning light	Details/Actions
 (flashes) (if equipped)	When a buzzer sounds: Indicates a malfunction in the PKSB (Parking Support Brake) system → Have the vehicle inspected by any authorized Lexus retailer or Lexus authorized repairer, or any reliable repairer immediately. When a buzzer does not sound: Indicates that the system is temporarily unavailable, possibly due to a sensor being dirty or covered with ice, etc. → Follow the instructions displayed on the multi-information display. (→P.327, 452)

■ Low fuel level warning light

Warning light	Details/Actions
	Indicates that remaining fuel is approximately 7.1L (1.9 gal., 1.6 Imp.gal.) or less → Refuel the vehicle.

■ Driver's and front passenger's seat belt reminder light (warning buzzer)*

Warning light	Details/Actions
	Warns the driver and/or front passenger to fasten their seat belts → Fasten the seat belt. If the front passenger's seat is occupied, the front passenger's seat belt also needs to be fastened to make the warning light (warning buzzer) turn off.

* : Driver's and front passenger's seat belt warning buzzer:

The driver's and front passenger's seat belt warning buzzer sounds to alert the driver and front passenger that his or her seat belt is not fastened. The buzzer sounds for 24 seconds after the vehicle reaches a speed of 20 km/h (12 mph). Then, if the seat belt is still unfastened,

tened, the buzzer will sound in a different tone for 100 more seconds.

■ Rear passengers' seat belt reminder lights ^{*1}(warning buzzer)^{*2}

Warning light	Details/Actions
	Warns the rear passengers to fasten their seat belts → Fasten the seat belt.

^{*1}: This light illuminates on the multi-information display.

^{*2}: Rear passengers' seat belt warning buzzer:

The rear passengers' seat belt warning buzzer sounds to alert the rear passenger that his or her seat belt is not fastened. The buzzer sounds for approximately 25 seconds after the vehicle reaches a speed of 20 km/h (12 mph). If the seat belt is still unfastened, the buzzer will sound in a different tone for 100 more seconds.

■ Brake Override System warning light/Drive-Start Control warning light/PKSB warning light ^{*} (warning buzzer)

Warning light	Details/Actions
	When a buzzer sounds: <ul style="list-style-type: none"> ● Brake Override System is malfunctioning; ● Drive-Start Control is operating; ● Drive-Start Control is malfunctioning; or ● Parking Support Brake function (for static objects) (if equipped) is operating → Follow the instructions displayed on the multi-information display and head-up display (if equipped). <p>When a buzzer does not sound: Brake Override System is operating → Release the accelerator pedal and depress the brake pedal.</p>

^{*}: This light illuminates on the multi-information display.

■ LTA indicator ^{*} (warning buzzer)

Warning light	Details/Actions
 (orange) (if equipped)	Indicates a malfunction in the LTA (Lane Tracing Assist) → Follow the instructions displayed on the multi-information display. (→P.277)

^{*}: This light illuminates on the multi-information display.

■ PCS warning light (warning buzzer)

Warning light	Details/Actions
 <p>(flashes or illuminates) (if equipped)</p>	<p>When a buzzer sounds simultaneously: Indicates a malfunction has occurred in the PCS (Pre-Collision System). → Have the vehicle inspected by any authorized Lexus retailer or Lexus authorized repairer, or any reliable repairer immediately.</p> <p>If a buzzer does not sound: The PCS (Pre-Collision System) has become temporarily unavailable, corrective action may be necessary. → Follow the instructions displayed on the multi-information display. (→P.258, 452, 454)</p> <p>If the PCS (Pre-Collision System) or VSC (Vehicle Stability Control) system is disabled, the PCS warning light will illuminate. → P.267</p>

■ Warning buzzer

In some cases, the buzzer may not be heard due to being in a noisy location or audio sound.

■ Front passenger detection sensor, seat belt reminder and warning buzzer

- If luggage is placed on the front passenger seat, the front passenger detection sensor may cause the warning light to flash and the warning buzzer to sound even if a passenger is not sitting in the seat.
- If a cushion is placed on the seat, the sensor may not detect a passenger, and the warning light may not operate properly.

■ If the malfunction indicator lamp comes on while driving

The malfunction indicator lamp will come on if the fuel tank becomes completely empty. If the fuel tank is empty, refuel the vehicle immediately. The malfunction indicator lamp will go off after several trips.

If the malfunction indicator lamp does not go off, contact any authorized Lexus retailer or Lexus authorized repairer, or any reliable repairer as soon as possible.

■ Electric power steering system warning light (warning buzzer)

When the battery charge becomes insufficient or the voltage temporarily drops, the electric power steering system warning light may come on and the warning buzzer may sound.

■ When the tire pressure warning light comes on

Inspect the tires to check if a tire is punctured.

If a tire is punctured: →P.455, 467, 476

If none of the tires are punctured:
Turn the engine switch off then turn it to ON. Check if the tire pressure warning light comes on or blinks.

- ▶ If the tire pressure warning light blinks for approximately 1 minute then stays on

There may be a malfunction in the tire pressure warning system. Have the vehicle inspected by any authorized Lexus retailer or Lexus authorized repairer, or any reliable repairer immediately.

- ▶ If the tire pressure warning light comes on

- 1 After the temperature of the tires has lowered sufficiently, check the inflation

pressure of each tire and adjust them to the specified level.

- 2** If the warning light does not turn off even after several minutes have elapsed, check that the inflation pressure of each tire is at the specified level and perform initialization. (→P.420)

■ **The tire pressure warning light may come on due to natural causes**

The tire pressure warning light may come on due to natural causes such as natural air leaks and tire inflation pressure changes caused by temperature. In this case, adjusting the tire inflation pressure will turn off the warning light (after a few minutes).

■ **When a tire is replaced with a spare tire (vehicles with spare tire)**

The compact spare tire is not equipped with a tire pressure warning valve and transmitter. If a tire goes flat, the tire pressure warning light will not turn off even though the flat tire has been replaced with the spare tire. Replace the spare tire with the repaired tire and adjust the tire inflation pressure. The tire pressure warning light will go off after a few minutes.

■ **Conditions that the tire pressure warning system may not function properly**

→P.411



WARNING

■ **If both the ABS and the brake system warning lights remain on**

Stop your vehicle in a safe place immediately and contact any authorized Lexus retailer or Lexus authorized repairer, or any reliable repairer.

The vehicle will become extremely unstable during braking, and the ABS system may fail, which could cause an accident resulting in death or serious injury.

■ **When the electric power steering system warning light comes on**

When the light comes on yellow, the assist to the power steering is restricted. When the light comes on red, the assist to the power steering is lost and handling operations of the steering wheel become extremely heavy.

When steering wheel operations are heavier than usual, grip the steering wheel firmly and operate it using more force than usual.

■ **If the tire pressure warning light comes on (vehicles without run-flat tires)**

Be sure to observe the following precautions.

Failure to do so could cause a loss of vehicle control and result in death or serious injury.

- Stop your vehicle in a safe place as soon as possible. Check and adjust the tire inflation pressure immediately.

- If the tire pressure warning light comes on even after tire inflation pressure adjustment, it is probable that you have a flat tire. Check the tires. If a tire is flat, change it with the spare tire and have the flat tire repaired by the nearest any authorized Lexus retailer or Lexus authorized repairer, or any reliable repairer.

- Avoid abrupt maneuvering and braking. If the vehicle tires deteriorate, you could lose control of the steering wheel or the brakes.

■ **If the tire pressure warning light comes on (vehicles with run-flat tires)**

Be sure to observe the following precautions.

Failure to do so could cause a loss of vehicle control and result in death or serious injury.

⚠ WARNING

- Decelerate to the lowest appropriate speed as soon as possible. Do not drive over 80 km/h (50 mph).
- Check and adjust the tire inflation pressure immediately.
- If the tire pressure warning light comes on even after tire inflation pressure adjustment, it is probable that you have a flat tire. Have the flat tire replaced by the nearest any authorized Lexus retailer or Lexus authorized repairer, or any reliable repairer.
- Avoid abrupt maneuvering and braking. If the vehicle tires deteriorate, you could lose control of the steering wheel or the brakes.

■ **If a blowout or sudden air leakage should occur**

The tire pressure warning system may not activate immediately.

⚠ NOTICE

■ **To ensure the tire pressure warning system operates properly**

Do not install tires with different specifications or makers, as the tire pressure warning system may not operate properly.

If a warning message is displayed

The multi-information display shows warnings of system malfunctions, incorrectly performed operations, and messages that indicate a need for maintenance. When a message is shown, perform the correction procedure appropriate to the message.

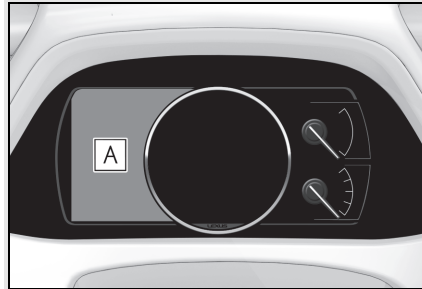

A Multi-information display

Follow the instructions of the message on the multi-information display.

If any of the warning messages are shown again after the following actions have been performed, contact any authorized Lexus retailer or Lexus authorized repairer, or any reliable repairer.

Messages and warnings

The warning lights and warning buzzers operate as follows depending on the content of the message. If a message indicates the need for inspection by a dealer, have the vehicle inspected by any authorized Lexus retailer or Lexus authorized repairer, or any reliable repairer immediately.

Warning light	Warning buzzer *	Warning
—	Sounds	<ul style="list-style-type: none"> Indicates an important situation, such as when a system related to driving is malfunctioning or that danger may result if the correction procedure is not performed Indicates a situation, such as when damage to the vehicle or danger may result
Comes on or flashes	Sounds	Indicates an important situation, such as when the systems shown on the multi-information display may be malfunctioning
—	Does not sound	<ul style="list-style-type: none"> Indicates a condition, such as malfunction of electrical components, their condition, or indicates the need for maintenance Indicates a situation, such as when an operation has been performed incorrectly, or indicates how to perform an operation correctly

* : A buzzer sounds the first time a message is shown on the multi-information display.

■ Warning messages

The warning messages explained below may differ from the actual messages according to operation conditions and vehicle specifications.

■ Warning buzzer

In some cases, the buzzer may not be heard due to being in a noisy location or audio sound.

■ If "Engine Oil Level Low Add or Replace" is displayed

The engine oil level is low. Check the level of the engine oil, and add if necessary.

This message may appear if the vehicle is stopped on a slope. Move the vehicle to a

level surface and check to see if the message disappears.

■ If "Engine Stopped Steering Power Low" is displayed

This message is displayed if the engine is stopped while driving.

When steering wheel operations are heavier than usual, grip the steering wheel firmly and operate it using more force than usual.

■ If "Auto Power Off To Conserve Battery" is displayed

Power was turned off due to the automatic power off function. Next time when starting the engine, increase the engine speed slightly and maintain that level for approximately 5 minutes to recharge the battery.

■ If “High Power Consumption Power to Climate Temporarily Limited” is displayed

Turn off unnecessary electronic equipment to reduce power consumption.

Please wait until the power supply returns to normal.

■ If “Headlight System Malfunction Visit Your Dealer” is displayed

The following systems may be malfunctioning. Have the vehicle inspected by any authorized Lexus retailer or Lexus authorized repairer, or any reliable repairer immediately.

- The LED headlight system
- The automatic headlight leveling system
- AHS (Adaptive High-beam System) (if equipped)
- Automatic High Beam (if equipped)

■ If “Radar Cruise Control Unavailable” is shown

The dynamic radar cruise control with full-speed range system cannot be used temporarily. Use the system when it becomes available again.

■ If “Front Camera Unavailable” or “Front Camera Temporarily Unavailable See Owner’s Manual” is displayed

The following systems may be suspended until the problem shown in the message is resolved. (→P.258, 450)

- PCS (Pre-Collision System) (if equipped)
- LTA (Lane Tracing Assist) (if equipped)
- AHS (Adaptive High-beam System) (if equipped)
- Automatic High Beam (if equipped)
- RSA (Road Sign Assist) (if equipped)
- Dynamic radar cruise control with full-speed range (if equipped)

■ If “Oil Maintenance Required Soon” is displayed

Indicates that the engine oil should be scheduled to be changed.

Check the engine oil and change it if neces-

sary. After changing the engine oil, make sure to reset the message. (→P.404)

■ If “Oil Maintenance Required” is displayed

Indicates that the engine oil should be changed.

Check and change the engine oil, and oil filter by any authorized Lexus retailer or Lexus authorized repairer, or any reliable repairer. After changing the engine oil, make sure to reset the message. (→P.404)

■ If a message that indicates the need for visiting any authorized Lexus retailer or Lexus authorized repairer, or any reliable repairer is displayed

The system or part shown on the multi-information display is malfunctioning. Have the vehicle inspected any authorized Lexus retailer or Lexus authorized repairer, or any reliable repairer immediately.

■ If a message that indicates the need for referring to Owner’s Manual is displayed

- If any of the following messages are shown on the multi-information display, follow the instructions.
 - “Engine Coolant Temp High” (→P.485)
 - “Exhaust Filter Full” (→P.339)
 - “Transmission Oil Temp. High” (→P.220)
 - “Front Camera Temporarily Unavailable” (→P.258)
 - “Radar Cruise Control Temporarily Unavailable” (→P.258)
- If “Entry & Start System Malfunction” is shown on the multi-information display, it may indicate a malfunction. Have the vehicle inspected by any authorized Lexus retailer or Lexus authorized repairer, or any reliable repairer immediately.
- If any of the following messages are shown on the multi-information display, it may indicate a malfunction. Immediately stop the vehicle and contact any authorized Lexus retailer or Lexus authorized repairer, or any reliable repairer.
 - “Braking Power Low”
 - “Charging System Malfunction”
 - “Oil Pressure Low”

**NOTICE**

- If “High Power Consumption Power to Climate Temporarily Limited” is displayed frequently

There is a possible malfunction relating to the charging system or the battery may be deteriorating. Have the vehicle inspected by any authorized Lexus retailer or Lexus authorized repairer, or any reliable repairer.

If you have a flat tire (vehicles with emergency tire puncture repair kit)

Your vehicle is not equipped with a spare tire, but instead is equipped with an emergency tire puncture repair kit.

A puncture caused by a nail or screw passing through the tire tread can be repaired temporarily using the emergency tire puncture repair kit. (The kit contains a bottle of sealant. The sealant can be used only once to temporarily repair one tire without removing the nail or screw from the tire.) Depending on the damage condition of the flat tire, it may not be able to repaired with the emergency tire puncture repair kit.

After temporarily repairing the tire with the kit, have the tire repaired or replaced by any authorized Lexus retailer or Lexus authorized repairer, or any reliable repairer.

**WARNING**

- If you have a flat tire

Do not continue driving with a flat tire. Driving even a short distance with a flat tire can damage the tire and the wheel beyond repair, which could result in an accident.

Before repairing the vehicle

- Stop the vehicle in a safe place on a

hard, flat surface.

- Set the parking brake.
- Shift the shift lever to P.
- Stop the engine.
- Turn on the emergency flashers.
- Check the degree of the tire damage.

A tire should only be repaired with the emergency tire puncture repair kit if the damage is caused by a nail or screw passing through the tire tread.

- Do not remove the nail or screw from the tire. Removing the object may widen the opening and make emergency repair with the repair kit impossible.
- To avoid sealant leakage, move the vehicle until the area of the puncture, if known, is positioned at the top of the tire.

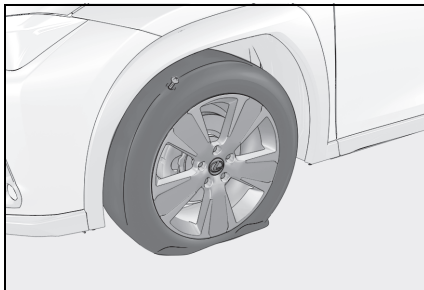

■ **A flat tire that cannot be repaired with the emergency tire puncture repair kit**

In the following cases, the tire cannot be repaired with the emergency tire puncture repair kit. Contact any authorized Lexus retailer or Lexus authorized repairer, or any reliable repairer.

- When the tire is damaged due to driving without sufficient air pressure
- When there are any cracks or damage at any location on the tire, such as on the side wall, except the tread
- When the tire is visibly separated from the wheel
- When the cut or damage to the tread is 4 mm (0.16 in.) long or more
- When the wheel is damaged
- When two or more tires have been punctured
- When more than one sharp objects such as nails or screws have passed through the tread on a single tire

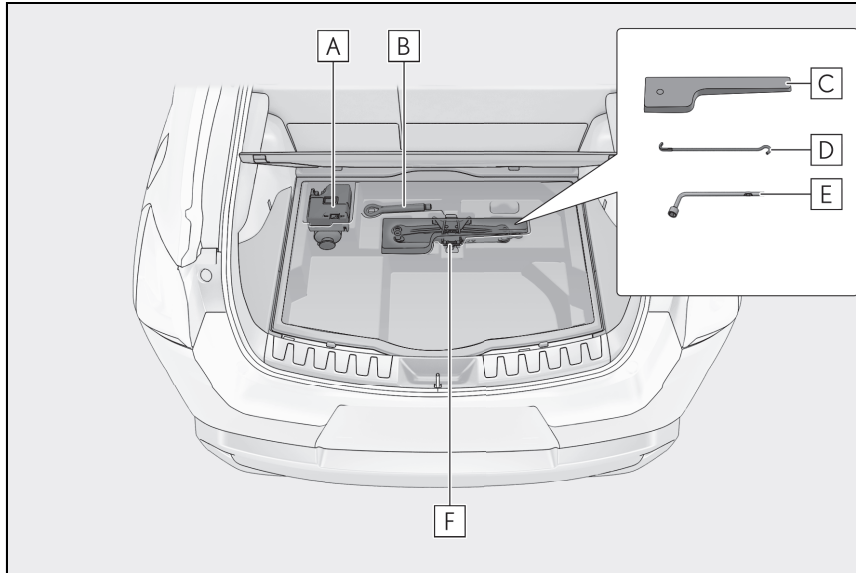
Location of the emergency tire puncture repair kit and tools

- A** Emergency tire puncture repair kit
 - B** Towing eyelet
 - C** Tool bag
 - D** Jack handle
 - E** Wheel nut wrench
 - F** Jack
- (Use of the jack: →P.470)

Emergency tire puncture repair kit components

■ **Bottle**

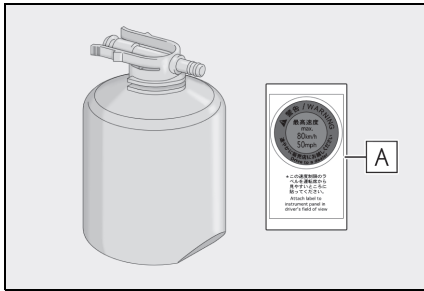

A Sticker

■ **Compressor**

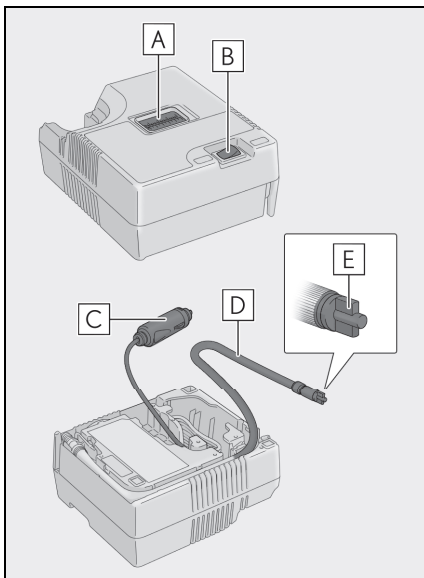

A Air pressure gauge

B Compressor switch

C Power plug

D Hose

E Air release cap

■ **Emergency tire puncture repair kit**

- The sealant stored in the emergency tire puncture repair kit can be used only once to temporarily repair a single tire. If the sealant in the bottle and other parts of the kit have been used and need to be replaced, contact any authorized Lexus retailer or Lexus authorized repairer, or any reliable repairer.
 - The compressor can be used repeatedly.
 - The sealant can be used when the outside temperature is from -30°C (-22°F) to 60°C (140°F).
 - The kit is exclusively designed for size and type of tires originally installed on your vehicle. Do not use it for tires that a different size than the original ones, or for any other purposes.
 - If the sealant gets on your clothes, it may stain.
 - If the sealant adheres to a wheel or the surface of the vehicle body, the stain may not be removable if it is not cleaned at once. Immediately wipe away the sealant with a wet cloth.
 - During operation of the repair kit, a loud operation noise is produced. This does not indicate a malfunction.
 - Do not use to check or to adjust the tire pressure.
- **Note for checking the emergency tire puncture repair kit**
- Check the sealant expiry date occasionally. The expiry date is shown on the bottle.
 - Do not use sealant whose expiry date has already passed. Otherwise, repairs conducted using the emergency tire puncture repair kit may not be performed properly.
 - The sealant should be replaced before the expiry date. Contact any authorized Lexus retailer or Lexus authorized repairer, or any reliable repairer for replacement.

⚠ WARNING**■ If you have a flat tire**

Driving even a short distance with a flat tire can damage the tire and the wheel beyond repair.

Driving with a flat tire may cause a circumferential groove on the side wall. In such a case, the tire may explode when using a repair kit.

■ Caution while driving

- Store the repair kit in the luggage compartment. Injuries may result in the event of an accident or sudden braking.
- The repair kit is exclusively only for your vehicle. Do not use repair kit on other vehicles, which could lead to an accident causing death or serious injury.
- Do not use repair kit for tires that are different size than the original ones, or for any other purpose. If the tires have not been completely repaired, it could lead to an accident causing death or serious injury.
- **Precautions for use of the sealant**
 - Ingesting the sealant is hazardous to your health. If you ingest sealant, consume as much water as possible, then immediately consult a doctor.
 - If sealant gets in eyes or adheres to skin, immediately wash it off with water. If discomfort persists, consult a doctor.

Taking out the emergency tire puncture repair kit

- 1 Pull the lever upwards and open the deck board.

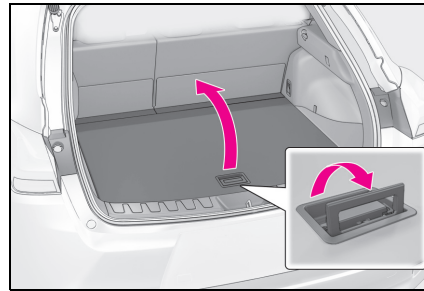

- 2 Unhook the string on the backside of the deck board.

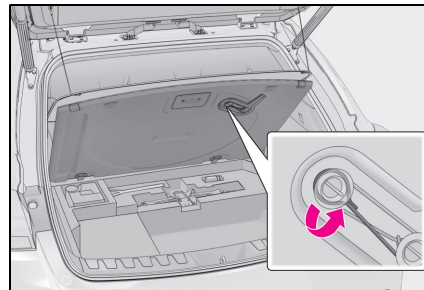

- 3 Attach the string to the luggage cover hook on the back door.

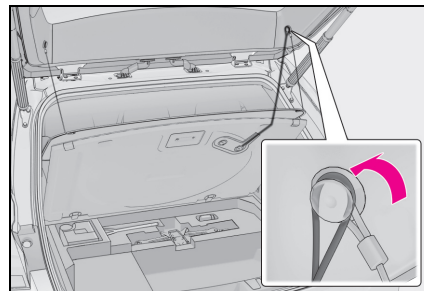

- 4 Take out the emergency tire puncture repair kit.

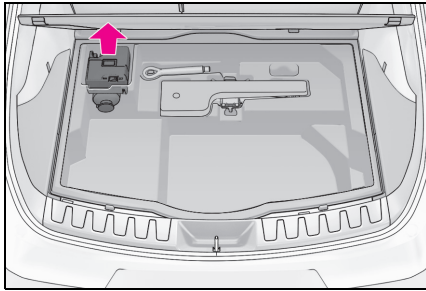

Taking out the jack

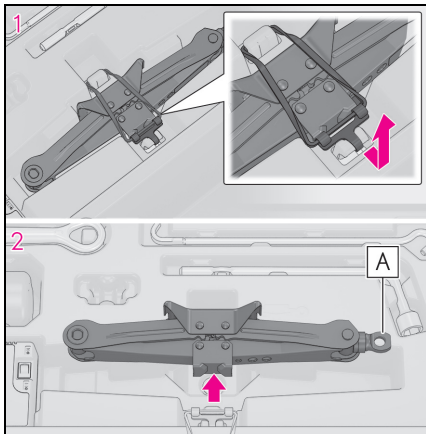

- 1 Unhook the rubber band.
 2 Take out the jack.
 Remove the tool bag, and then take out the jack.
 Use of the jack: →P.470
 When stowing the jack, close it by turning the handle indicated by **A** until it does not move anymore, place the jack and fix it with the rubber band.

Emergency repair procedure

- 1 Take out the repair kit from the plastic bag.

Attach the sticker enclosed with the bottle on the specified locations. (See step 10.)

- 2 Remove the hose and take out the power plug from the compressor.

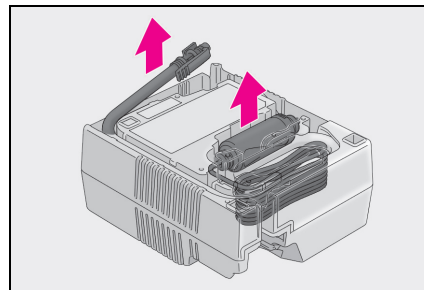

- 3 Connect the bottle to the compressor.

Insert and connect the bottle straight into the compressor as shown in the illustration, and check that the claws of the bottle are concealed in the holes.

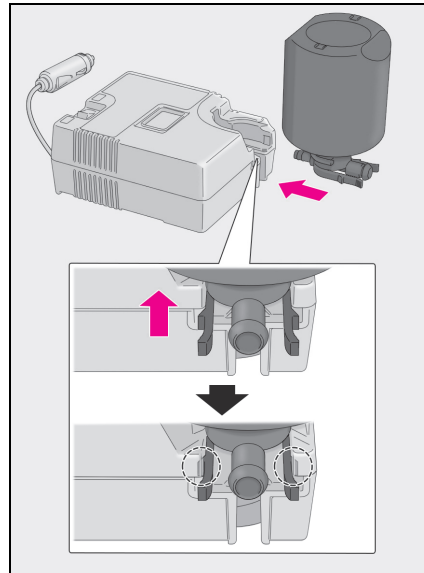

4 Connect the hose to the bottle.

As shown in the illustration, make sure the hose is connected securely to the bottle.

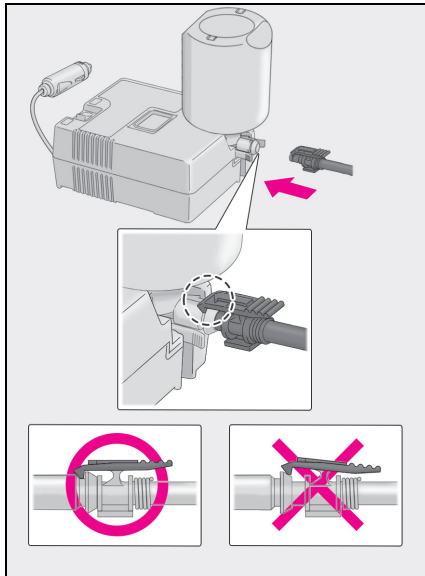
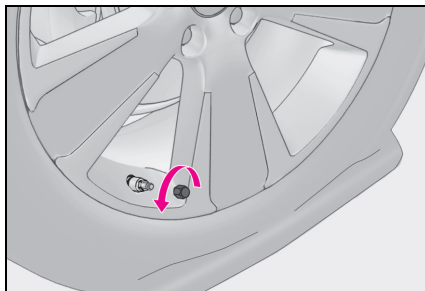
**5** Remove the valve cap from the valve of the punctured tire.**6** Extend the hose. Remove the air release cap from the hose.

You will use the air release cap again.

Therefore keep it in a safe place.

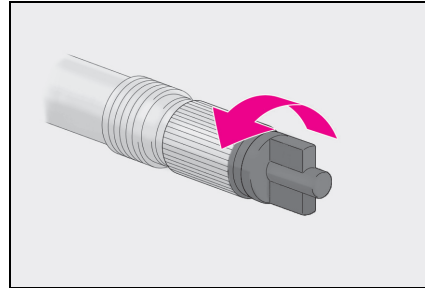
**7** Connect the hose to the valve.

Screw the end of the hose clockwise as far as possible.

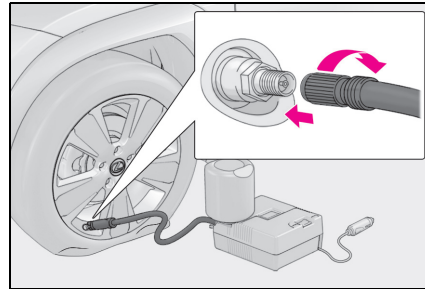
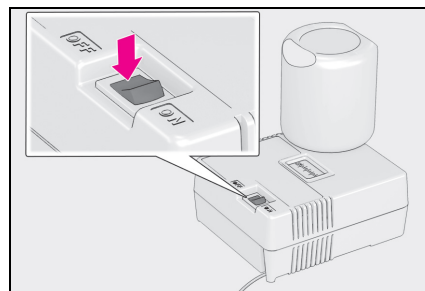
**8** Make sure that the compressor switch is off.**9** Connect the power plug to the power outlet socket. (→P.381)

▶ Front

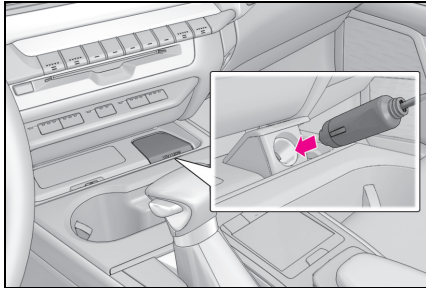

▶ Rear

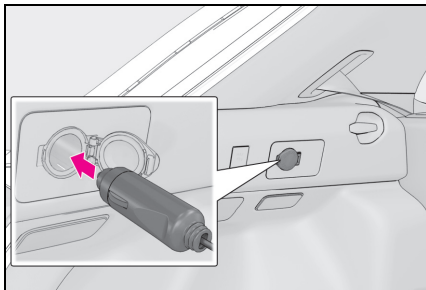

10 Attach the sticker provided with the tire puncture repair kit to a position easily seen from the driver's seat.

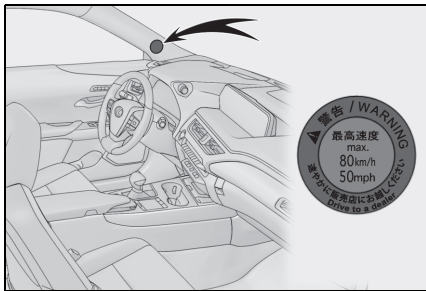

11 Check the specified tire inflation pressure.

Tire inflation pressure is specified on the label as shown. (→P.496)

▶ Left-hand drive vehicles

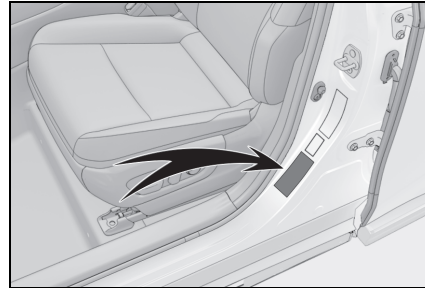

▶ Right-hand drive vehicles

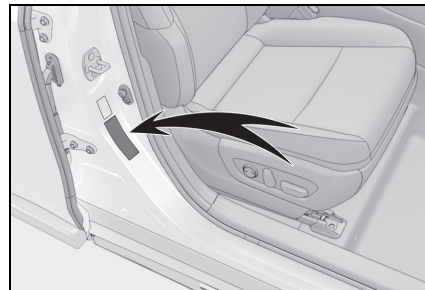

12 Start the engine. (→P.217)

13 To inject the sealant and inflate the tire, turn the compressor switch on.

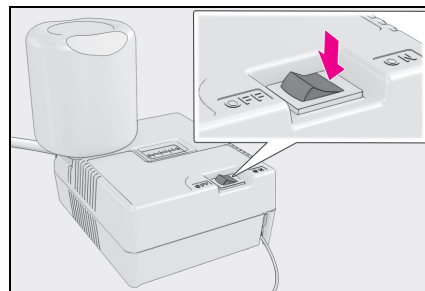

- 14** Inflate the tire until the recommended pressure is reached.

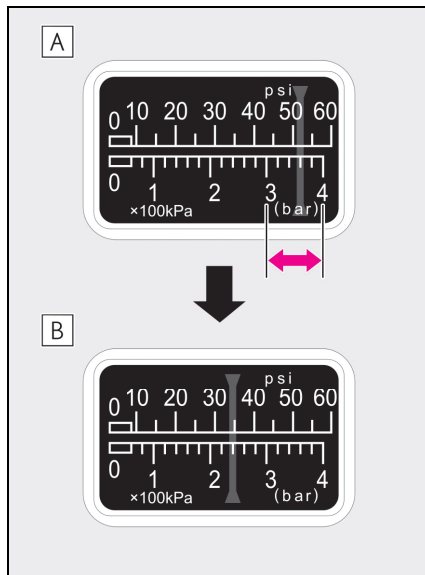

A The sealant will be injected and the pressure will spike to 300 kPa (3.0 kgf/cm² or bar, 44 psi) or 400 kPa (4.0 kgf/cm² or bar, 58 psi), then gradually decrease.

B The air pressure gauge will display the actual tire inflation pressure about 1 to 5 minutes after the switch is turned on.

- Turn the compressor switch off and then check the tire inflation pressure. Being careful not to over inflate, check and repeat the inflation procedure until the specified tire inflation pressure is reached.
- The tire can be inflated for about 5 to 20 minutes (depending on the outside temperature). If the tire inflation pressure is still lower than the specified point after inflation for 25 minutes, the tire is too

damaged to be repaired. Turn the compressor switch off and contact any authorized Lexus retailer or Lexus authorized repairer, or any reliable repairer.

- If the tire inflation pressure exceeds the specified air pressure, let out some air to adjust the tire inflation pressure. (→P.465)

15 pull out the power plug from the power outlet socket and then disconnect the hose from the valve on the tire.

Some sealant may leak when the hose is removed.

16 Install the valve cap onto the valve of the emergency repaired tire.

17 Attach the air release cap to the end of the hose.

If the air release cap is not attached, the sealant may leak and the vehicle may get dirty.

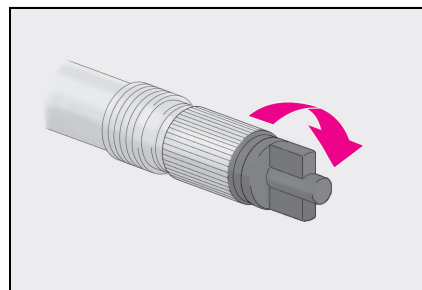

18 Temporarily store the bottle in the luggage compartment while it is connected to the compressor.

19 To spread the liquid sealant evenly within the tire, immediately drive safely for about 5 km (3 miles) below 80 km/h (50 mph).

20 After driving, stop your vehicle in a safe place on a hard, flat surface and reconnect the repair kit.

Remove the air release cap from the hose before reconnecting the hose.

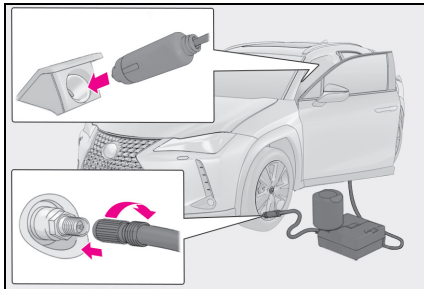

21 Turn the compressor switch on and wait for several seconds, then turn it off. Check the tire inflation pressure.

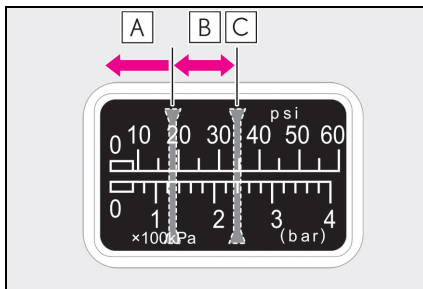

A If the tire inflation pressure is under 130 kPa (1.3 kgf/cm² or bar, 19 psi): The puncture cannot be repaired. Contact any authorized Lexus retailer or Lexus authorized repairer, or any reliable repairer.

B If the tire inflation pressure is 130 kPa (1.3 kgf/cm² or bar, 19 psi) or higher, but less than the specified air pressure: Proceed to step **22**.

C If the tire inflation pressure is the

specified air pressure (→P.496): Proceed to step **23**.

22 Turn the compressor switch on to inflate the tire until the specified air pressure is reached. Drive for about 5 km (3 miles) and then perform step **20**.

23 Attach the air release cap to the end of the hose.

If the air release cap is not attached, the sealant may leak and the vehicle may get dirty.

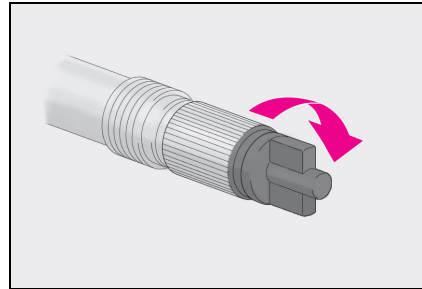

24 Store the bottle in the luggage compartment while it is connected to the compressor.

25 Taking precautions to avoid sudden braking, sudden acceleration and sharp turns, drive carefully at under 80 km/h (50 mph) to the nearest authorized Lexus retailer or Lexus authorized repairer, or any reliable repairer that is less than 100 km (62 miles) away for tire repair or replacement.

For repair and replacement of a tire or disposal of the tire puncture repair kit, contact any authorized Lexus retailer or Lexus authorized repairer, or any reliable repairer.

When having the tire repaired or replaced, make sure to tell any authorized Lexus

retailer or Lexus authorized repairer, or any reliable repairer that the sealant is injected.

■ **If the tire is inflated to more than the specified air pressure**

- 1 Disconnect the hose from the valve.
- 2 Install the air release cap to the end of the hose and push the protrusion on the air release cap into the valve to let some air out.

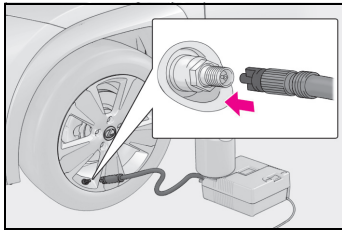

- 3 Disconnect the hose from the valve, remove the air release cap from the hose and then reconnect the hose.
- 4 Turn the compressor switch on and wait for several seconds, then turn it off. Check that the air pressure indicator shows the specified air pressure is reached. (→P.496)
If the air pressure is under the designated pressure, turn the compressor switch on again and repeat the inflation procedure until the specified air pressure is reached.

■ **After a tire is repaired with the emergency tire puncture repair kit**

- The tire pressure warning valve and transmitter should be replaced.
- Even if the tire inflation pressure is at the recommended level, the tire pressure warning light may come on/flash.

⚠ WARNING

■ **When fixing the flat tire**

- Stop your vehicle in a safe and flat area.

- Do not touch the wheels or the area around the brakes immediately after the vehicle has been driven. After the vehicle has been driven, the wheels and the area around the brakes may be extremely hot. Touching these areas with hands, feet or other body parts may result in burns.

- Connect the valve and hose securely with the tire installed on the vehicle.

If the hose is not properly connected to the valve, air leakage may occur as sealant may be sprayed out.

- If the hose comes off the valve while inflating the tire, there is a risk that the hose will move abruptly due to air pressure.

- After inflation of the tire has completed, the sealant may splatter when the hose is disconnected or some air is let out of the tire.

- Follow the operation procedure to repair the tire. If the procedures not followed, the sealant may spray out.

- Keep back from the tire while it is being repaired, as there is a chance of it bursting while the repair operation is being performed. If you notice any cracks or deformation of the tire, turn off the compressor switch and stop the repair operation immediately.

- The repair kit may overheat if operated for a long period of time. Do not operate the compressor continuously for more than 40 minutes.

- Parts of the repair kit become hot during operation. Be careful handling the repair kit during and after operation. Do not touch the metal part connecting the bottle and the compressor. It will be extremely hot.

**WARNING**

- Do not attach the vehicle speed warning sticker to an area other than the one indicated. If the sticker is attached to an area where an SRS airbag is located, such as the pad of the steering wheel, it may prevent the SRS air bag from operating properly.
- **Driving to spread the liquid sealant evenly**
 - Drive the vehicle carefully at a low speed. Be especially careful when turning and cornering.
 - If the vehicle does not drive straight or you feel a pull through the steering wheel, stop the vehicle and check the following:
 - Tire condition. The tire may have separated from the wheel.
 - Tire inflation pressure. If the tire inflation pressure is 130 kPa (1.3 kgf/cm² or bar, 19 psi) or less, the tire may be severely damaged.

**NOTICE**

- **When performing an emergency repair**
 - Perform the emergency repair without removing the nail or screw that has punctured the tread of the tire. If the object that has punctured the tire is removed, repair by the emergency tire puncture repair kit may not be possible.
 - The repair kit is not waterproof. Make sure that the repair kit is not exposed to water, such as when it is being used in the rain.
 - Do not put the repair kit directly onto dusty ground such as sand at the side of the road. If the repair kit vacuums up dust, etc., a malfunction may occur.

- Make sure the sealant bottle of the repair kit is in a vertical position. The repair kit does not operate properly when it is laid.

- **Precautions for the emergency tire puncture repair kit**

- The repair kit power source should be 12 V DC suitable for vehicle use. Do not connect the repair kit to any other source.
- If fuel splatters on the repair kit, the repair kit may deteriorate. Take care not to allow fuel to contact it.
- Place the repair kit in a storage to prevent it from being exposed to dirt or water.
- Store the repair kit in the luggage compartment out of reach of children.
- Do not disassemble or modify the repair kit. Do not subject parts such as the air pressure indicator to impacts. This may cause a malfunction.

- **To avoid damage to the tire pressure warning valves and transmitters**

When a tire is repaired with liquid sealants, the tire pressure warning valve and transmitter may not operate properly. If a liquid sealant is used, contact any authorized Lexus retailer or Lexus authorized repairer, or any reliable repairer or other qualified service shop as soon as possible. After use of liquid sealant, make sure to replace the tire pressure warning valve and transmitter when repairing or replacing the tire. (→P.419)

If you have a flat tire (vehicles with spare tire)

Your vehicle is equipped with a spare tire. The flat tire can be replaced with the spare tire.

For details about tires: →P.409

WARNING

■ If you have a flat tire

Do not continue driving with a flat tire. Driving even a short distance with a flat tire can damage the tire and the wheel beyond repair, which could result in an accident.

Before jacking up the vehicle

- Stop the vehicle in a safe place on a hard, flat surface.
- Set the parking brake.
- Shift the shift lever to P.
- Stop the engine.
- Turn on the emergency flashers. (→P.436)

Location of the spare tire, jack and tools

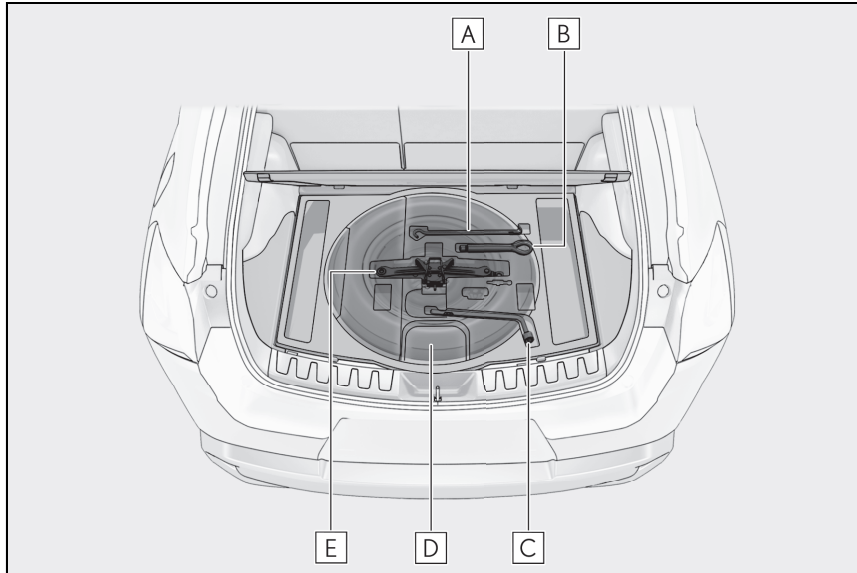

- A** Jack handle
- B** Towing eyelet
- C** Wheel nut wrench
- D** Spare tire
- E** Jack

⚠ WARNING

■ Using the tire jack

Observe the following precautions. Improper use of the tire jack may cause the vehicle to suddenly fall off the jack, leading to death or serious injury.

- Do not use the tire jack for any purpose other than replacing tires or installing and removing tire chains.
- Only use the tire jack that comes with this vehicle for replacing a flat tire. Do not use it on other vehicles, and do not use other tire jacks for replacing tires on this vehicle.

- Put the jack properly in its jack point.
- Do not put any part of your body under the vehicle while it is supported by the jack.
- Do not start the engine or drive the vehicle while the vehicle is supported by the jack.
- Do not raise the vehicle while someone is inside.
- When raising the vehicle, do not put an object on or under the jack.

⚠ WARNING

- Do not raise the vehicle to a height greater than that required to replace the tire.
- Use a jack stand if it is necessary to get under the vehicle.
- When lowering the vehicle, make sure that there is no-one near the vehicle. If there are people nearby, warn them vocally before lowering.

Taking out the jack

- 1 Pull the lever upwards and open the deck board.

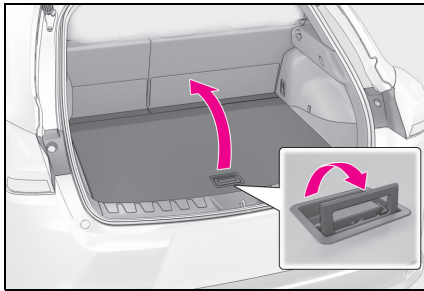

- 2 Remove the deck board.

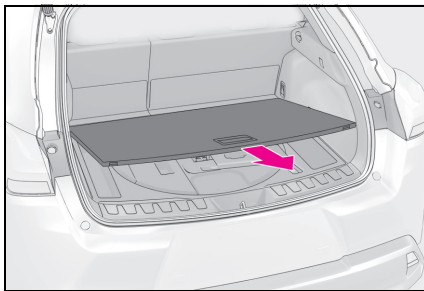

- 3 Remove the Jack.

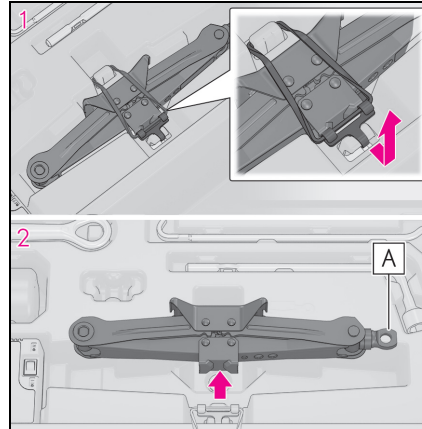

- 1 Unhook the rubber band.
- 2 Take out the jack.

When stowing the jack, close it by turning the handle indicated by **A** until it does not move anymore, place the jack and fix it with the rubber band.

Taking out the spare tire

- 1 Remove the side deck boards. (→P.376)
- 2 Remove deck under tray.

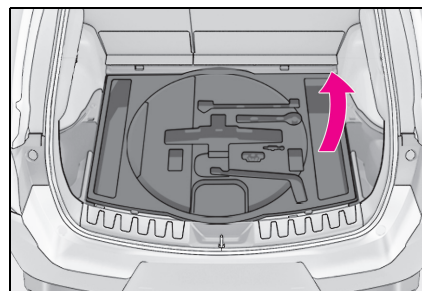

- 3 Loosen the center fastener that secures the spare tire.

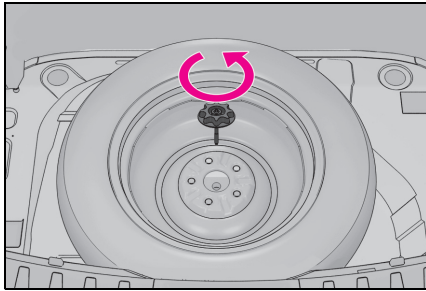

⚠ WARNING

■ **When storing the spare tire**

Be careful not get fingers or other body parts caught between the spare tire and the body of the vehicle.

Replacing a flat tire

- 1 Check the tires.

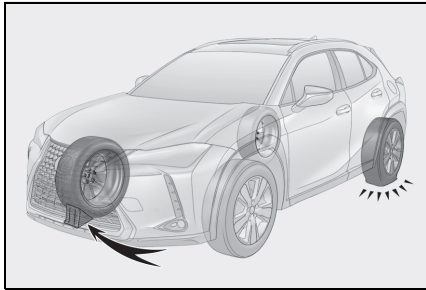

Flat tire	Wheel chock positions
Front left-hand side	Behind the rear right-hand side tire
Front right-hand side	Behind the rear left-hand side tire
Rear left-hand side	In front of the front right-hand side tire
Rear right-hand side	In front of the front left-hand side tire

- 2 Slightly loosen the wheel nuts (one turn).

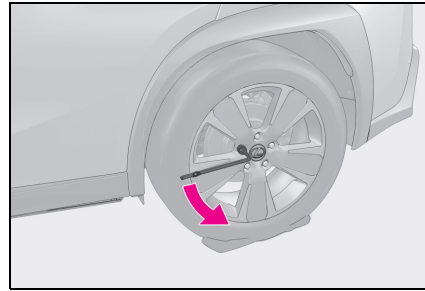

- 3 Turn the tire jack portion **A** by hand until the notch of the jack is in contact with the jack point.

The jack point guides are located under the rocker panel. They indicate the jack point positions.

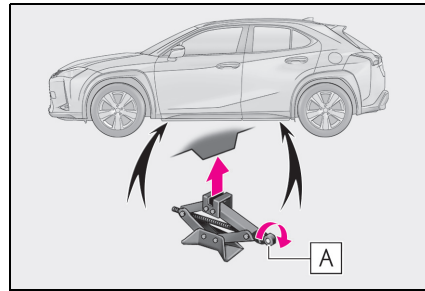

- 4 Install the wheel nut wrench in jack handle.

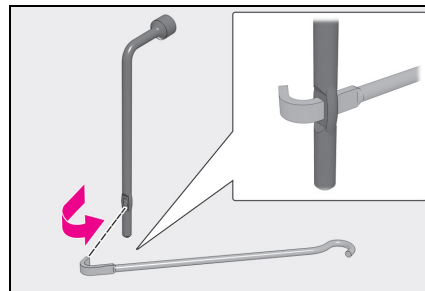

- 5 Raise the vehicle until the tire is slightly raised off the ground.

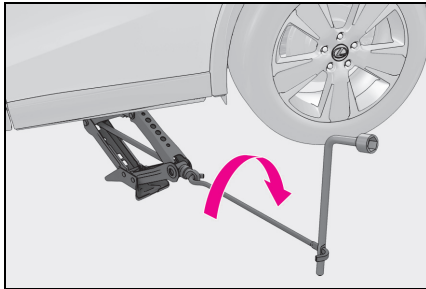

- 6 Remove all the wheel nuts and the tire.

When resting the tire on the ground, place the tire so that the wheel design faces up to avoid scratching the wheel surface.

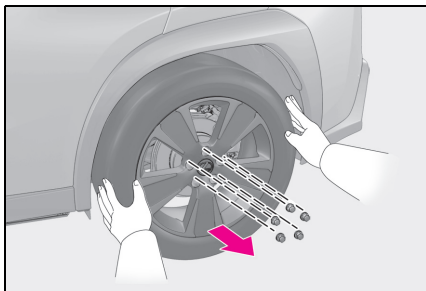

⚠ WARNING

■ Replacing a flat tire

- Do not touch the disc wheels or the area around the brakes immediately after the vehicle has been driven. After the vehicle has been driven the disc wheels and the area around the brakes will be extremely hot. Touching these areas with hands, feet or other body parts while changing a tire, etc., may result in burns.
- Failure to follow these precautions could cause the wheel nuts to loosen and the tire to fall off, resulting in death or serious injury.

- Never use oil or grease on the wheel bolts or wheel nuts. Oil and grease may cause the wheel nuts to be excessively tightened, leading to bolt or disc wheel damage. In addition, the oil or grease can cause the wheel nuts to loosen and the wheel may fall off, causing a serious accident. Remove any oil or grease from the wheel bolts or wheel nuts.
- Have the wheel nuts tightened with a torque wrench to 103 N•m (10.5 kgf•m, 76 ft•lbf) as soon as possible after changing wheels.
- When installing a tire, only use wheel nuts that have been specifically designed for that wheel.
- If there are any cracks or deformations in the bolt screws, nut threads or bolt holes of the wheel, have the vehicle inspected by any authorized Lexus retailer or Lexus authorized repairer, or any reliable repairer.
- Do not attach a heavily damaged wheel ornament, as it may fly off the wheel while the vehicle is moving.

■ Replacing a flat tire for vehicles with power back door

In cases such as when replacing tires, make sure to cancel the power back door system (→P.149). Failure to do so may cause the back door to operate unintentionally if the power back door switch is accidentally touched, resulting in hands and fingers being caught and injured.

Installing the spare tire

- 1 Remove any dirt or foreign matter from the wheel contact surface.

If foreign matter is on the wheel contact surface, the wheel nuts may loosen while the vehicle is in motion, causing the tire to

come off.

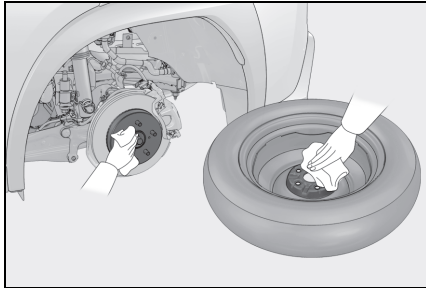

2 Install the spare tire and loosely tighten each wheel nut by hand by approximately the same amount.

Tighten the wheel nuts until the tapered portion **A** comes into loose contact with the disc wheel seat **B**.

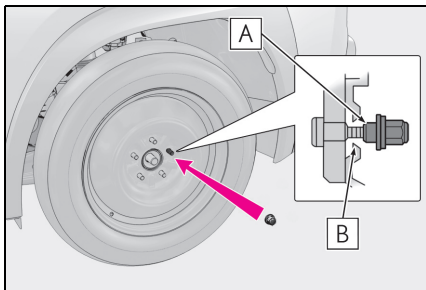

3 Lower the vehicle.

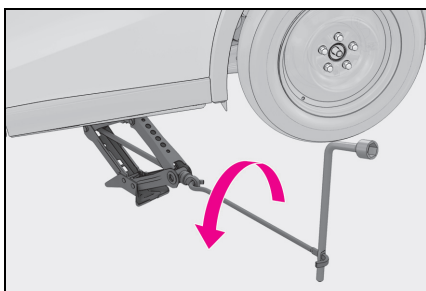

4 Firmly tighten each wheel nut two or three times in the order shown in the illustration.

Tightening torque:

103 N•m (10.5 kgf•m, 76 ft•lb)

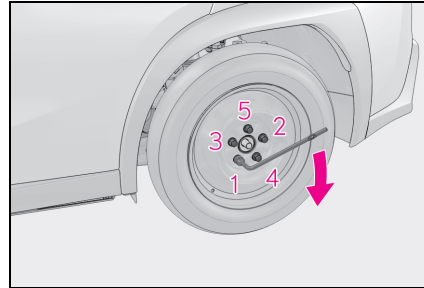

5 Stow the flat tire, tire jack and all tools.

■ **The compact spare tire**

- The compact spare tire is identified by the label "TEMPORARY USE ONLY" on the tire sidewall. Use the compact spare tire temporarily, and only in an emergency.
- Make sure to check the tire inflation pressure of the compact spare tire. (→P.496)

■ **After completing the tire change**

The tire pressure warning system must be reset. (→P.420)

■ **When using the compact spare tire**

As the compact spare tire is not equipped with a tire pressure warning valve and transmitter, low inflation pressure of the spare tire will not be indicated by the tire pressure warning system. Also, if you replace the compact spare tire after the tire pressure warning light comes on, the light remains on.

■ **When the compact spare tire is equipped**

The vehicle becomes lower when driving with the compact spare tire compared to when driving with standard tires.

■ **If you have a flat front tire on a road covered with snow or ice**

Install the compact spare tire on one of the rear wheels of the vehicle. Perform the following steps and fit tire chains to the front tires:

- 1 Replace a rear tire with the compact spare tire.
- 2 Replace the flat front tire with the tire removed from the rear of the vehicle.
- 3 Fit tire chains to the front tires.

■ Certification for the jack



Manufacturer's Declaration of Conformity

Manufacturer:

Kawasaki Industrial Co., Ltd.
1131 Kamo Kikugawa, Shizuoka, Japan

The EU Directives covered by this Declaration

2006/42/EC Machinery Directive

The product covered by this declaration

JACK SUB-ASSY,PANTOGRAPH

model

0.8ton , 1.1ton , 1.35ton , 1.4ton , 1.5ton

The basis on which conformity is being declared

The product identified above complies with the requirements of
the Machinery Directive
Directive above by meeting following standards

JIS D 8103

The technical documentation required to demonstrate that the product
meets the requirement the Machinery Directive has been compiled by
the signatory below and is available for inspection by the relevant
enforcement authorities.

A sample of the product has been tested by the manufacturer

Technical File No: KSF-201-00-04

The CE mark was first applied in:2010

Done at Shizuoka, Japan

Signature:

A handwritten signature in black ink, appearing to read 'Koji Kawasaki', is written over a horizontal line.

Koji Kawasaki
PRESIDENT ,Kawasaki Industrial Co., Ltd.

Date of Issue: 1 MARCH ,2018

 **WARNING****■ When using the compact spare tire**

- Remember that the spare tire provided is specifically designed for use with your vehicle. Do not use your spare tire on another vehicle.
- Do not use more than one spare tire simultaneously.
- Replace the spare tire with a standard tire as soon as possible.
- Avoid sudden acceleration, abrupt steering, sudden braking and shifting operations that cause sudden engine braking.

■ When the compact spare tire is attached

The vehicle speed may not be correctly detected, and the following systems may not operate correctly:

- ABS & Brake assist
- VSC
- TRC
- Cruise control (if equipped)
- Dynamic radar cruise control with full-speed range (if equipped)
- PCS (Pre-Collision System) (if equipped)
- EPS
- AVS (if equipped)
- LTA (Lane Tracing Assist) (if equipped)
- Panoramic view monitor (if equipped)
- Lexus parking assist monitor (if equipped)
- Lexus parking assist-sensor (if equipped)
- Navigation system (if equipped)
- BSM (Blind Spot Monitor) (if equipped)
- Automatic High Beam (if equipped)
- AHS (Adaptive High-beam System) (if equipped)

■ Speed limit when using the compact spare tire

Do not drive at speeds in excess of 80 km/h (50 mph) when a compact spare tire is installed on the vehicle.

The compact spare tire is not designed for driving at high speeds. Failure to observe this precaution may lead to an accident causing death or serious injury.

■ After using the tools and jack

Before driving, make sure all the tools and jack are securely in place in their storage location to reduce the possibility of personal injury during a collision or sudden braking.

 NOTICE

■ **Be careful when driving over bumps with the compact spare tire installed on the vehicle**

The vehicle becomes lower when driving with the compact spare tire compared to when driving with standard tires. Be careful when driving over uneven road surfaces.

■ **Driving with tire chains and the compact spare tire**

Do not fit tire chains to the compact spare tire. Tire chains may damage the vehicle body and adversely affect driving performance.

■ **When replacing the tires**

When removing or fitting the wheels, tires or the tire pressure warning valve and transmitter, contact any authorized Lexus retailer or Lexus authorized repairer, or any reliable repairer as the tire pressure warning valve and transmitter may be damaged if not handled correctly.

If you have a flat tire (vehicles with run-flat tires)

Your vehicle is not equipped with a spare tire and emergency tire puncture repair kit, but instead you can continue driving the vehicle with run-flat tires even if any tire goes flat.

In this case, slow down and drive with extra caution.

Run-flat tires

Take your vehicle to the nearest authorized Lexus retailer or Lexus authorized repairer, or any reliable repairer, or authorized tire dealer as soon as possible if any tire goes flat.

The vehicle can be driven for a maximum of 160 km (100 miles) at a speed below 80 km/h (50 mph) after the tire pressure warning light comes on. (→P.445)

A run-flat tire has a  mark on the sidewall.

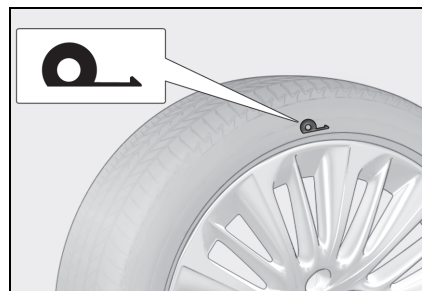

■ **In some conditions (such as at high temperatures)**

You cannot continue driving for up to 160 km (100 miles).

■ For the detailed information on run-flat tires

→P.411

 NOTICE

■ When replacing the tires

When removing or fitting the wheels, tires or the tire pressure warning valve and transmitter, contact any authorized Lexus retailer or Lexus authorized repairer, or any reliable repairer as the tire pressure warning valve and transmitter may be damaged if not handled correctly.

■ When driving over bumps

If a vehicle has a flat tire, the vehicle height will be lower than usual. Ensure that nothing strikes the bottom of the vehicle.

■ To avoid damage to the tire pressure warning valves and transmitters

When a tire is repaired with liquid sealants, the tire pressure warning valve and transmitter may not operate properly. If a liquid sealant is used, contact any authorized Lexus retailer or Lexus authorized repairer, or any reliable repairer or other qualified service shop as soon as possible. Make sure to replace the tire pressure warning valve and transmitter when replacing the tire. (→P.419)

If the engine will not start

If the engine will not start even though correct starting procedures are being followed (→P.217), consider each of the following points:

The engine will not start even though the starter motor operates normally

One of the following may be the cause of the problem:

- There may not be sufficient fuel in the vehicle's tank.
Refuel the vehicle.
- The engine may be flooded.
Try to restart the engine again following correct starting procedures. (→P.217)
- There may be a malfunction in the engine immobilizer system. (→P.84)

The starter motor turns over slowly, the interior lights and headlights are dim, or the horn does not sound or sounds at a low volume.

One of the following may be the cause of the problem:

- The battery terminal connections may be loose or corroded.
- The battery may be discharged. (→P.482)

The starter motor does not turn over

The engine starting system may be malfunctioning due to an electrical problem such as electronic key battery depletion or a blown fuse. However, an interim measure is available to start the engine. (→P.478)

The starter motor does not turn over, the interior lights and headlights do not turn on, or the horn does not sound.

One of the following may be the cause of the problem:

- One or both of the battery terminals may be disconnected.
- The battery may be discharged. (→P.482)
- There may be a malfunction in the steering lock system.

Contact any authorized Lexus retailer or Lexus authorized repairer, or any reliable repairer if the problem cannot be repaired, or if repair procedures are unknown.

Starting the engine in an emergency

When the engine does not start, the following steps can be used as an interim measure to start the engine if the engine switch is functioning normally:

- 1 Press the parking brake switch to check that the parking brake is set. (→P.225)

Parking brake indicator will come on.

- 2 Shift the shift lever to P.
- 3 Turn the engine switch to ACC.
- 4 Press and hold the engine switch for about 15 seconds while depressing the brake pedal firmly.

Even if the engine can be started using the above steps, the system may be malfunctioning. Have the vehicle inspected by any authorized Lexus retailer or Lexus authorized repairer, or any reliable repairer.

If you lose your keys

New genuine mechanical keys can be made by any authorized Lexus retailer or Lexus authorized repairer, or any reliable repairer using another mechanical key and the key number stamped on your key number plate. Keep the plate in a safe place such as your wallet, not in the vehicle.

NOTICE

■ When an electronic key is lost

If the electronic key remains lost, the risk of vehicle theft increases significantly. Visit any authorized Lexus retailer or Lexus authorized repairer, or any reliable repairer immediately with all remaining electronic keys and the card key that were provided with your vehicle.

If the fuel filler door cannot be opened

If the fuel filler door opener switch cannot be operated, the following procedure can be used to open the fuel filler door.

Opening the fuel filler door

- 1 Remove the cover inside the luggage compartment by inserting a screwdriver. When removing the cover, to prevent damage, cover the tip of the screwdriver with a rag.

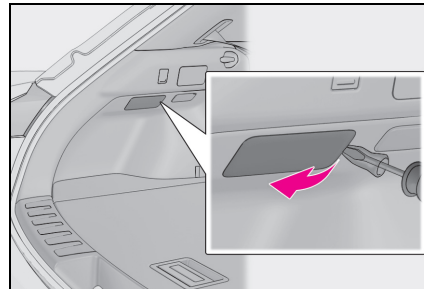

- 2 Pull the lever.

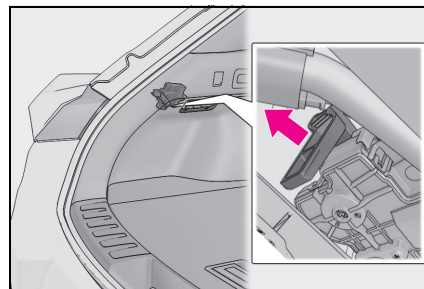

If the electronic key does not operate properly

If communication between the electronic key and vehicle is interrupted (→P.153) or the electronic key cannot be used because the battery is depleted, the smart entry & start system and wireless remote control cannot be used. In such cases, the doors can be opened and the engine can be started by following the procedure below.

■ **When the electronic key does not work properly**

- Make sure that the smart entry & start system has not been deactivated using the Remote Touch or at any authorized Lexus retailer or Lexus authorized repairer, or any reliable repairer. If it is off, turn the function on.
- Check if battery-saving mode is set. If it is set, cancel the function. (→P.152)

 **NOTICE**

■ **In case of a smart entry & start system malfunction or other key related problems**

Take your vehicle with all the electronic keys provided with your vehicle, including the card key, to any authorized Lexus retailer or Lexus authorized repairer, or any reliable repairer.

Locking and unlocking the doors

■ **Unlocking the door**

Use the mechanical key to perform the following operations. (→P.132)

- 1 Insert the mechanical key while pulling on the driver's door handle.

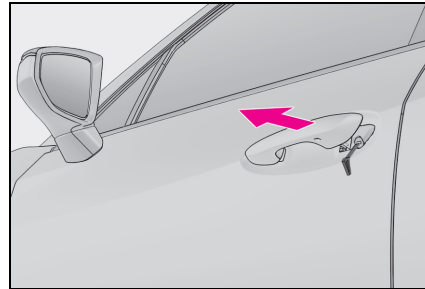

- 2 Unlock the door.

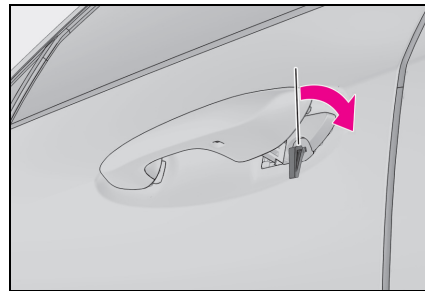

- 3 Remove the key, return the handle, and then pull the handle again.

■ **Locking the door**

- 1 With the door open, push down the inside lock button.

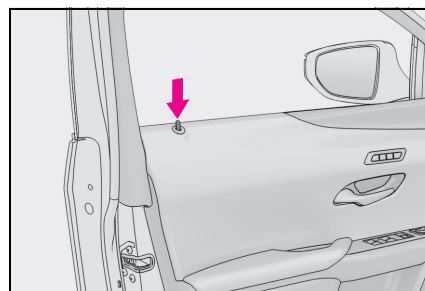

- ▶ For the front doors

- 2 Close the door while pulling the door handle.

- ▶ For the rear doors
- 2 Close the door.

■ Key linked functions

The opening and closing of the power windows and moon roof can be linked to key operation by a customized setting.

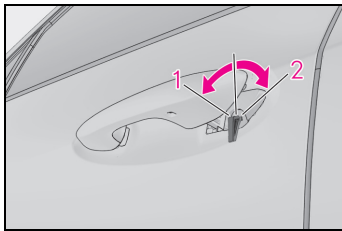

- 1 Closes the windows and moon roof (turn and hold)
- 2 Opens the windows and moon roof (turn and hold)

⚠ WARNING

■ When using the mechanical key and operating the power windows or moon roof (if equipped)

Operate the power window or moon roof after checking to make sure that there is no possibility of any passenger having any of their body parts caught in the window or moon roof. Also, do not allow children to operate the wireless remote control or mechanical key. It is possible for children and other passengers to get caught in the power window or moon roof.

Starting the engine

- 1 Ensure that the shift lever is in P and depress the brake pedal.
- 2 Touch the Lexus emblem side of the electronic key to the engine switch.

When the electronic key is detected, a buzzer sounds and the engine switch will

turn to ON.

When the smart entry & start system is deactivated in customization setting, the engine switch will turn to ACC.

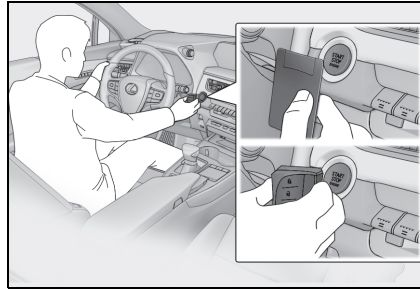

- 3 Firmly depress the brake pedal and check that  is shown on the multi-information display.
- 4 Press the engine switch.

In the event that the engine still cannot be started, contact any authorized Lexus retailer or Lexus authorized repairer, or any reliable repairer.

■ Stopping the engine

Shift the shift lever to P, set the parking brake and press the engine switch as you normally do when stopping the engine.

■ Electronic key battery

As the above procedure is a temporary measure, it is recommended that the electronic key battery be replaced immediately when the battery is depleted. (→P.428)

■ Alarm (if equipped)

Using the mechanical key to lock the doors will not set the alarm system. If a door is unlocked using the mechanical key when the alarm system is set, the alarm may be triggered. (→P.97)

■ Changing engine switch modes

Release the brake pedal and press the engine switch in step 3 above. The engine does not start and modes will be changed each time the switch is pressed. (→P.219)

If the vehicle battery is discharged

The following procedures may be used to start the engine if the vehicle's battery is discharged. You can also call any authorized Lexus retailer or Lexus authorized repairer, or any reliable repairer.

Restarting the engine

If you have a set of jumper (or booster) cables and a second vehicle with a battery, you can jump start your vehicle by following the steps below.

- 1 Confirm that the electronic key is being carried.

When connecting the jumper (or booster) cables, depending on the situation, the alarm may activate and the doors may lock.

- 4 Connect a positive jumper cable clamp to **A** on your vehicle and connect the clamp on the other end of the positive cable to **B** on the second vehicle. Then, connect a negative cable clamp to **C** on the second vehicle and connect the clamp at the other end of the negative cable to **D**.

(→P.98)

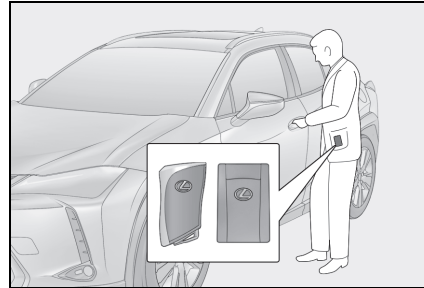

- 2 Open the hood (→P.400).

- 3 Open the positive (+) battery terminal cover.

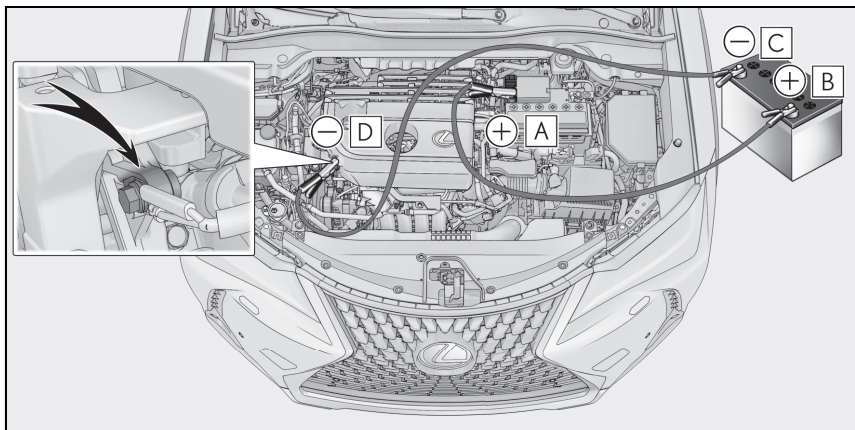
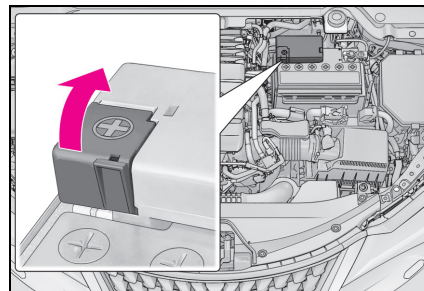

- A** Positive (+) battery terminal (your vehicle)
 - B** Positive (+) battery terminal (second vehicle)
 - C** Negative (-) battery terminal (second vehicle)
 - D** Solid, stationary, unpainted metallic point away from the battery and any moving parts as shown in the illustration
- 5** Start the engine of the second vehicle. Increase the engine speed slightly and maintain at that level for approximately 5 minutes to recharge the battery of your vehicle.
 - 6** Open and close any of the doors of your vehicle with the engine switch OFF.
 - 7** Maintain the engine speed of the second vehicle and start the engine of your vehicle by turning the engine switch to ON.
 - 8** Once the vehicle's engine has started, remove the jumper cables in the exact reverse order from which they were connected.

Once the engine starts, have the vehicle inspected at any authorized Lexus retailer or Lexus authorized repairer, or any reliable repairer as soon as possible.

■ Starting the engine when the battery is discharged

The engine cannot be started by push-starting.

■ To prevent battery discharge

- Turn off the headlights, the air conditioning system, the audio system, etc. while the engine is off.
- Turn off any unnecessary electrical com-

ponents when the vehicle is running at a low speed for an extended period, such as in heavy traffic.

■ Charging the battery

The electricity stored in the battery will discharge gradually even when the vehicle is not in use, due to natural discharge and the draining effects of certain electrical appliances. If the vehicle is left for a long time, the battery may discharge, and the engine may be unable to start. (The battery recharges automatically during driving.)

■ When the battery is removed or discharged

- Information stored in the ECU is cleared. When the battery is depleted, have the vehicle inspected at any authorized Lexus retailer or Lexus authorized repairer, or any reliable repairer.
- In some cases, it may not be possible to unlock the doors using the smart entry & start system when the battery is discharged. Use the wireless remote control or the mechanical key to lock or unlock the doors.
- The engine may not start on the first attempt after the battery has recharged but will start normally after the second attempt. This is not a malfunction.
- The engine switch mode is memorized by the vehicle. When the battery is reconnected, the system will return to the mode it was in before the battery was discharged. Before disconnecting the battery, turn the engine switch off. If you are unsure what mode the engine switch was in before the battery discharged, be especially careful when reconnecting the battery.
- The power back door must be initialized.

(→P.146)

- Vehicle with Stop & Start system: For a while after the battery terminals have been disconnected and reconnected, for a while after the battery has been replaced, the Stop & Start system may not automatically stop the engine for approximately 5 to 60 minutes.

■ Replacing the battery

Vehicle with Stop & Start system: Use a genuine battery specifically designed for use with the Stop & Start system or a battery with equivalent specifications to a genuine battery.

If an unsupported battery is used, Stop & Start system functions may be restricted to protect the battery. Also, battery performance may decrease and the engine may not be able to restart. Contact any authorized Lexus retailer or Lexus authorized repairer, or any reliable repairer for details.

■ When replacing the battery

Use a genuine battery (European Regulations) specifically designed for use with the Stop & Start system.

- If an improper battery is used, the Stop & Start system may not be operated, or the engine may not even be able to restart after the engine is stopped by the Stop & Start system.
- Use a battery that the case size is same as the previous one (LN3), 20 hour rate capacity (20HR) is equivalent (70Ah) or greater, and performance rating (CCA) is equivalent (592A) or greater.
 - If the sizes differ, the battery cannot be properly secured.
 - If an improper battery is used, battery performance may decrease and the engine may not be able to restart.
 - If the 20 hour rate capacity is low, even if the time period where the vehicle is not used is a short time, the battery may discharge and the engine may not be able to start.

For details, consult with at any authorized Lexus retailer or Lexus authorized repairer, or any reliable repairer as soon as possible.

WARNING

■ When removing the battery terminals

Always remove the negative (-) terminal first. If the positive (+) terminal contacts any metal in the surrounding area when the positive (+) terminal is removed, a spark may occur, leading to a fire in addition to electrical shocks and death or serious injury.

■ Avoiding battery fires or explosions

Observe the following precautions to prevent accidentally igniting the flammable gas that may be emitted from the battery:

- Make sure each jumper cable is connected to the correct terminal and that it is not unintentionally in contact with any other than the intended terminal.
- Do not allow the other end of the jumper cable connected to the "+" terminal to come into contact with any other parts or metal surfaces in the area, such as brackets or unpainted metal.
- Do not allow the + and - clamps of the jumper cables to come into contact with each other.
- Do not smoke, use matches, cigarette lighters or allow open flame near the battery.

■ Battery precautions

The battery contains poisonous and corrosive acidic electrolyte, while related parts contain lead and lead compounds. Observe the following precautions when handling the battery:

- When working with the battery, always wear safety glasses and take care not to allow any battery fluids (acid) to come into contact with skin, clothing or the vehicle body.
- Do not lean over the battery.

⚠ WARNING

- In the event that battery fluid (acid) comes into contact with the skin or eyes, immediately wash the affected area with water and seek medical attention.
Place a wet sponge or cloth over the affected area until medical attention can be received.
- Always wash your hands after handling the battery and other battery-related parts.
- Do not allow children near the battery.
- **When replacing the battery**
- When the vent plug is close to the hold down clamp, the battery fluid (acid) may leak.
- For information regarding battery replacement, contact any authorized Lexus retailer or Lexus authorized repairer, or any reliable repairer.

⚠ NOTICE

- **When handling jumper cables**
When connecting the jumper cables, ensure that they do not become entangled in the cooling fan or engine drive belt.

If your vehicle overheats**The following may indicate that your vehicle is overheating.**

- The engine coolant temperature gauge (→P.108, 111) enters the red zone, or a loss of engine power is experienced. (For example, the vehicle speed does not increase.)
- “Engine Coolant Temp High Stop in a Safe Place See Owner’s Manual” is shown on the multi-information display.
- Steam comes out from under the hood.

Correction procedures

- 1 Stop the vehicle in a safe place and turn off the air conditioning system, and then stop the engine.
- 2 If you see steam:
Carefully lift the hood after the steam subsides.
If you do not see steam:
Carefully lift the hood.
- 3 After the engine has cooled down sufficiently, inspect the hoses and

radiator core (radiator) for any leaks.

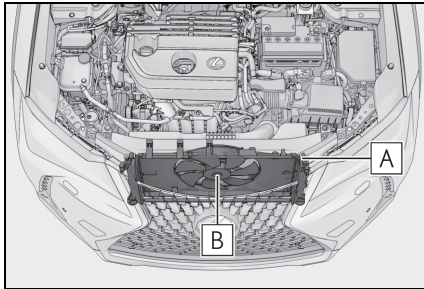

A Radiator

B Cooling fan

If a large amount of coolant leaks, immediately contact any authorized Lexus retailer or Lexus authorized repairer, or any reliable repairer.

- 4 The coolant level is satisfactory if it is between the "FULL" and "LOW" lines on the reservoir.

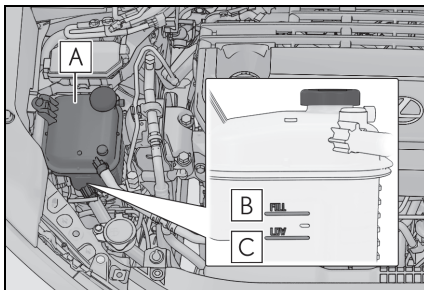

A Reservoir

B "FULL" line

C "LOW" line

- 5 Add coolant if necessary.

Water can be used in an emergency if

coolant is unavailable.

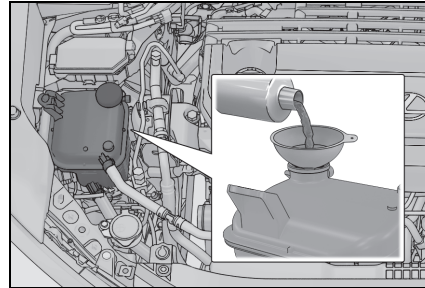

- 6 Start the engine and turn the air conditioning system on to check that the radiator cooling fan operates and to check for coolant leaks from the radiator or hoses.

The fan operates when the air conditioning system is turned on immediately after a cold start. Confirm that the fan is operating by checking the fan sound and air flow. If it is difficult to check these, turn the air conditioning system on and off repeatedly. (The fan may not operate in freezing temperatures.)

- 7 If the fan is not operating:

Stop the engine immediately and contact any authorized Lexus retailer or Lexus authorized repairer, or any reliable repairer.

If the fan is operating:

Have the vehicle inspected at the nearest authorized Lexus retailer or Lexus authorized repairer, or any reliable repairer.

- 8 Check if "Engine Coolant Temp High Stop in a Safe Place See Owner's Manual" is shown on the multi-information display. If the message does not disappear: Stop the engine and contact any authorized Lexus retailer or Lexus authorized repairer, or any reliable repairer.

If the message is not displayed:

Have the vehicle inspected at the nearest authorized Lexus retailer or Lexus authorized repairer, or any reliable repairer.

WARNING

■ To prevent an accident or injury when inspecting under the hood of your vehicle

Observe the following precautions. Failure to do so may result in serious injury such as burns.

- If steam is seen coming from under the hood, do not open the hood until the steam has subsided. The engine compartment may be very hot.
- Keep hands and clothing (especially a tie, a scarf or a muffler) away from the fan and belts. Failure to do so may cause the hands or clothing to be caught, resulting in serious injury.
- Do not loosen the coolant reservoir cap while the engine and radiator are hot. High temperature steam or coolant could spray out.

NOTICE

■ When adding engine coolant

Add coolant slowly after the engine has cooled down sufficiently. Adding cool coolant to a hot engine too quickly can cause damage to the engine.

■ To prevent damage to the cooling system

Observe the following precautions:

- Avoid contaminating the coolant with foreign matter (such as sand or dust, etc.).
- Do not use any coolant additive.

If the vehicle becomes stuck

Carry out the following procedures if the tires spin or the vehicle becomes stuck in mud, dirt or snow:

Recovering procedure

- 1 Stop the engine. Shift the shift lever to P and set the parking brake.
- 2 Remove the mud, snow or sand from around the front wheels.
- 3 Place wood, stones or some other material under the front wheels to help provide traction.
- 4 Restart the engine.
- 5 Shift the shift lever to D or R and release the parking brake. Then, while exercising caution, depress the accelerator pedal.

■ When it is difficult to free the vehicle

Press the  switch to turn off TRC. (→P.340)

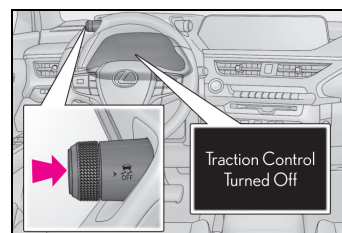



WARNING

■ **When attempting to free a stuck vehicle**

If you choose to push the vehicle back and forth to free it, make sure the surrounding area is clear to avoid striking other vehicles, objects or people. The vehicle may also lunge forward or lunge back suddenly as it becomes free. Use extreme caution.

■ **When shifting the shift lever**

Be careful not to shift the shift lever with the accelerator pedal depressed. This may lead to unexpected rapid acceleration of the vehicle that may cause an accident resulting in death or serious injury.



NOTICE

■ **To avoid damage to the transmission and other components**

- Avoid spinning the tires and depressing the accelerator pedal more than necessary.
- If the vehicle remains stuck even after these procedures are performed, the vehicle may require towing to be freed.

Vehicle specifications

8

489

8-1. Specifications

Maintenance data (fuel, oil level,
etc.) 490

Fuel information 499

8-2. Customization

Customizable features 501

8-3. Initialization

Items to initialize 515

8

Vehicle specifications

Maintenance data (fuel, oil level, etc.)

Dimensions and weights

Overall length		4495 mm (177.0 in.)
Overall width		1840 mm (72.4 in.)
Overall height ^{*1}		1520 mm (59.8 in.) ^{*2} 1540 mm (60.6 in.) ^{*3}
Wheelbase		2640 mm (103.9 in.)
Tread	Front	1560 mm (61.4 in.) ^{*4} 1550 mm (61.0 in.) ^{*5}
	Rear	1560 mm (61.4 in.) ^{*4} 1550 mm (61.0 in.) ^{*5}
Gross vehicle mass		1980 kg (4365 lb.)
Maximum permissible axle capacity	Front	1100 kg (2425 lb.)
	Rear	1200 kg (2646 lb.)
Drawbar load ^{*6}		75 kg (165 lb.)
Towing capacity ^{*6}		750 kg (1654 lb.)

^{*1}: Unladen vehicle

^{*2}: Vehicles with roof rail/without shark fin antenna

^{*3}: Vehicles with shark fin antenna

^{*4}: Vehicles with 215/60R17 tires

^{*5}: Vehicles with 225/50RF18 tires

^{*6}: Vehicles with towing package

Vehicle identification

■ Vehicle identification number

The vehicle identification number (VIN) is the legal identifier for your vehicle.

This is the primary identification number for your Lexus. It is used in registering the ownership of your vehicle.

This number is stamped on the top left of the instrument panel.

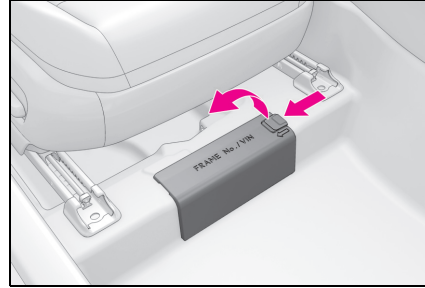

■ Engine number

The engine number is stamped on the engine block and engine cover as shown.



This number is also on the manufacturer's label.

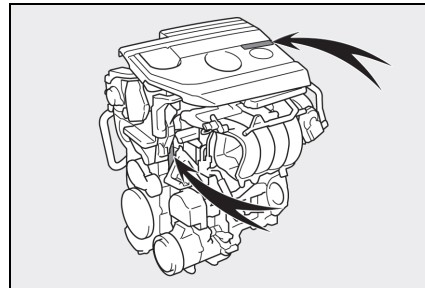

This number is also stamped under the right-hand front seat.

Engine	
Model	M20A-FKS
Type	4-cylinder in line, 4-cycle, gasoline
Bore and stroke	80.5 × 97.6 mm (3.17 × 3.84 in.)
Displacement	1987 cm ³ (121.3 cu.in.)
Valve clearance	Automatic adjustment
Drive belt tension	Automatic adjustment

Fuel	
Fuel type	<p>When you find these types of fuel label at the gas station, use only the fuel with one of the following labels.</p>  <p>EU area: Unleaded gasoline conforming to European standard EN228 only</p> <p>Except EU area: Unleaded gasoline only</p>
Research Octane Number	91 or higher ^{*1}
	95 or higher ^{*2}
Fuel tank capacity (Reference)	47 L (12.4 gal., 10.3 Imp.gal.)

^{*1}: For Azerbaijan, Armenia, Georgia, Russia, Ukraine and Kazakhstan

^{*2}: Except Azerbaijan, Armenia, Georgia, Russia, Ukraine and Kazakhstan

Lubrication system

■ **Oil capacity (Drain and refill — reference^{*})**

With filter	4.6 L (4.9 qt., 4.0 Imp.qt.)
Without filter	4.3 L (4.5 qt., 3.8 Imp.qt.)

^{*}: The engine oil capacity is a reference quantity to be used when changing the engine oil. Warm up and turn off the engine, wait more than 5 minutes, and check the oil level on the dipstick.

■ **Engine oil selection**

“Toyota Genuine Motor Oil” is used in your Lexus vehicle. Lexus recommends the use of approved “Toyota Genuine Motor Oil”. Another motor oil of matching quality can also be used.

Oil grade:

0W-16: API grade SN “Resource-Conserving” multigrade engine oil

0W-20, 5W-30 and 10W-30: API grade SL “Energy-Conserving”, SM “Energy-Conserving” or SN “Resource-Conserving”; or ILSAC multigrade engine oil

15W-40: API grade SL, SM or SN multigrade engine oil

Recommended viscosity (SAE): SAE 0W-16 is filled into your Lexus vehicle at manufacturing, and the best choice for good fuel economy and good starting in cold weather.

If SAE 0W-16 oil is not available, SAE

5W-20 oil may be used. However, it should be replaced with SAE 0W-16 at the next oil change.

If you use SAE 10W-30 or a higher viscosity engine oil in extremely low temperatures, the engine may become difficult to start, so SAE 0W-16, 0W-20 or 5W-30 engine oil is recommended.

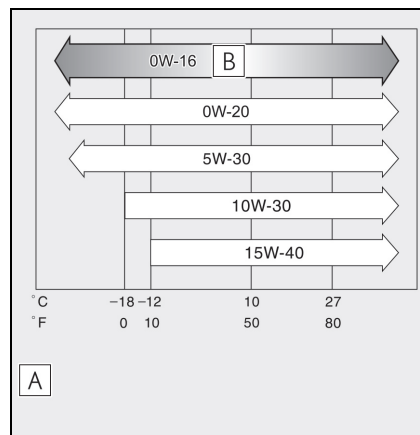

A Temperature range anticipated before next oil change

B Preferred

Oil viscosity (0W-16 is explained here as an example):

- The 0W in 0W-16 indicates the characteristic of the oil which allows cold startability. Oils with a lower value before the W allow for easier starting of the engine in cold weather.
- The 16 in 0W-16 indicates the viscosity characteristic of the oil when the oil is at high temperature. An oil

with a higher viscosity (one with a higher value) may be better suited if the vehicle is operated at high speeds, or under extreme load conditions.

How to read oil container labels:
 Either or both API registered marks are added to some oil containers to help you select the oil you should use.

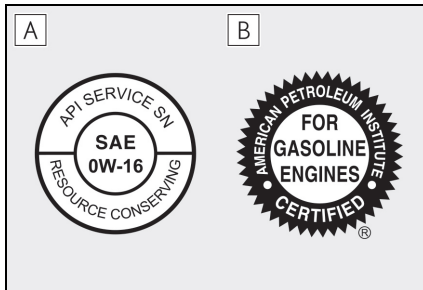

A API Service Symbol

Top portion: "API SERVICE SN" means the oil quality designation by American Petroleum Institute (API).

Center portion: "SAE 0W-16" means the SAE viscosity grade.

Lower portion: "Resource-Conserving" means that the oil has fuel-saving and environmental protection capabilities.

B ILSAC Certification Mark

The International Lubricant Specification Advisory Committee (ILSAC) Certification Mark is displayed on the front of the container.

Cooling system

Capacity*	6.5 L (6.9 qt., 5.7 Imp.qt.)
Coolant type	Use either of the following: <ul style="list-style-type: none"> • "Toyota Super Long Life Coolant" • Similar high-quality ethylene glycol-based non-silicate, non-amine, non-nitrite, and non-borate coolant with long-life hybrid organic acid technology Do not use plain water alone.

*: The coolant capacity is the quantity of reference.
 If replacement is necessary, contact any authorized Lexus retailer or Lexus authorized repairer, or any reliable repairer.

Ignition system

■ Spark plug

Make	DENSO FC20HR-Q8
Gap	0.8 mm (0.031 in.)



NOTICE

■ Iridium-tipped spark plugs

Use only iridium-tipped spark plugs. Do not adjust the spark plug gap.

Electrical system (battery)

Specific gravity reading at 20°C (68°F):	1.250 or higher
Charging rates:	
Quick charge	15 A max.
Slow charge	5 A max.

Multidrive

Fluid capacity*	8.2 L (8.7 qt., 7.2 Imp.qt.)
Fluid type	Toyota Genuine CVT Fluid FE

*: The fluid capacity is a reference quantity.

If replacement is necessary, contact any authorized Lexus retailer or Lexus authorized repairer, or any reliable repairer.



NOTICE

■ Multidrive fluid type

Using Multidrive fluid other than "Toyota Genuine CVT Fluid FE" may cause deterioration in shift quality, locking up of your transmission accompanied by vibration, and ultimately damage the transmission of your vehicle.

Brakes

Pedal clearance ^{*1}	101 mm (3.98 in.) Min.
Pedal free play	1.0 - 6.0 mm (0.04 - 0.24 in.)
Parking brake indicator ^{*2}	When pushing the parking brake switch for 1 to 4 seconds: comes on When pulling the parking brake switch for 1 to 4 seconds: turns off
Fluid type	SAE J1703 or FMVSS No. 116 DOT 3, SAE J1704 or FMVSS No. 116 DOT 4

*1: Minimum pedal clearance when depressed with a force of 300 N (31 kgf, 66 lbf) while the engine is running.

*2: Make sure to confirm that the brake system warning light (yellow) does not illuminate. (If the brake system warning light illuminates, refer to P.446)

Steering

Free play	Less than 30 mm (1.2 in.)
-----------	---------------------------

Tires and wheels

▶ 17-inch tires (type A)

Tire size	215/60R17 96H
Tire inflation pressure (Recommended cold tire inflation pressure)	Front: 250 kPa (2.5 kgf/cm ² or bar, 36 psi) Rear: 250 kPa (2.5 kgf/cm ² or bar, 36 psi)
Wheel size	17 × 6 1/2 J
Wheel nut torque	103 N•m (10.5 kgf•m, 76 ft•lbf)

► 17-inch tires (type B)

Tire size	215/60R17 96H
Tire inflation pressure (Recommended cold tire inflation pressure)	Front: 230 kPa (2.3 kgf/cm ² or bar, 33 psi) Rear: 230 kPa (2.3 kgf/cm ² or bar, 33 psi)
Wheel size	17 × 6 1/2 J
Wheel nut torque	103 N•m (10.5 kgf•m, 76 ft•lbf)

► 18-inch tires

Tire size	225/50RF18 95V
Tire inflation pressure (Recommended cold tire inflation pressure)	Front: 230 kPa (2.3 kgf/cm ² or bar, 33 psi) Rear: 230 kPa (2.3 kgf/cm ² or bar, 33 psi)
Wheel size	18 × 7 J
Wheel nut torque	103 N•m (10.5 kgf•m, 76 ft•lbf)

► Compact spare tire (type A)*

Tire size	T145/90D16 106M
Spare tire inflation pressure (Recommended cold tire inflation pressure)	420 kPa (4.2 kgf/cm ² or bar, 60 psi)
Wheel size	16 × 4T
Wheel nut torque	103 N•m (10.5 kgf•m, 76 ft•lbf)

*: if equipped

► Compact spare tire (type B)*

Tire size	T145/70D18 107M
Spare tire inflation pressure (Recommended cold tire inflation pressure)	420 kPa (4.2 kgf/cm ² or bar, 60 psi)
Wheel size	18 × 4T
Wheel nut torque	103 N•m (10.5 kgf•m, 76 ft•lbf)

*: if equipped

Light bulbs

	Light bulbs	W	Type
Exterior	Front turn signal lights (vehicles with single-beam headlights)	21	A
Interior	Vanity lights	8	B

A: Wedge base bulbs (amber)

B: Wedge base bulbs (clear)

Fuel information

When you find these types of fuel label at the gas station, use only the fuel with one of the following labels.



EU area:

You must only use unleaded gasoline conforming to European standard EN228.

Select unleaded gasoline with a Research Octane Number of 95 or higher for optimum engine performance.

Except EU area:

You must only use unleaded gasoline.

Except Azerbaijan, Armenia, Georgia, Russia, Ukraine and Kazakhstan: Select unleaded gasoline with a Research Octane Number of 95 or higher for optimum engine performance.

For Azerbaijan, Armenia, Georgia, Russia, Ukraine and Kazakhstan: Select unleaded gasoline with a Research Octane Number of 91 or higher for optimum engine performance.

■ Use of ethanol blended gasoline in a gasoline engine

Lexus allows the use of ethanol blended gasoline where the ethanol content is up to 10%. Make sure that the ethanol blended

gasoline to be used has an Research Octane Number that follows the above.

■ If your engine knocks

- Consult any authorized Lexus retailer or Lexus authorized repairer, or any reliable repairer.
- You may occasionally notice light knocking for a short time while accelerating or driving uphill. This is normal and there is no need for concern.



NOTICE

■ Notice on fuel quality

- Do not use improper fuels. If improper fuels are used, the engine will be damaged.
- Do not use gasoline with metallic additives, for example manganese, iron or lead, otherwise it may cause damage on your engine or emission control system.
- Do not add aftermarket fuel additives which contain metallic additives.
- EU area: Bioethanol fuel sold under names such as "E50" or "E85" and fuel containing a large amount of ethanol should not be used. The use of these fuels will damage the vehicle's fuel system. In case of any doubt, ask any authorized Lexus retailer or Lexus authorized repairer, or any reliable repairer.



NOTICE







- Except EU area: Bioethanol fuel sold under names such as "E50" or "E85" and fuel containing a large amount of ethanol should not be used. Your vehicle can use gasoline mixed with 10% max ethanol. The use of fuel with more than 10% ethanol content (E10) will damage the vehicle's fuel system. You must ensure that refueling is carried out only from a source where fuel specification and quality can be guaranteed. In case of any doubt, ask any authorized Lexus retailer or Lexus authorized repairer, or any reliable repairer.
- Do not use the methanol blended gasoline such as M15, M85, M100. The use of gasoline containing methanol may cause engine damage or failure.

Customizable features

Your vehicle includes a variety of electronic features that can be personalized to your preferences. The settings of these features can be changed by using the meter control switches, the Remote Touch or at any authorized Lexus retailer or Lexus authorized repairer, or any reliable repairer.

Customizing vehicle features

■ Changing using the meter control switches

- 1 Press  or  of the meter control switches, select .
- 2 Press  or  of the meter control switches, select the item, and press "OK".
- 3 Press  or  of the meter control switches, select the desired setting, and press "OK".

To go back to the previous screen or exit the customize mode, press .

■ Changing using the Remote Touch

- 1 Press the "MENU" button on the Remote Touch.

- 2 Select "Setup" on the menu screen and select "Vehicle".
- 3 Select "Vehicle customisation" or "Drive mode customisation".

Various setting can be changed. Refer to the list of settings that can be changed for details.

For details on the Remote Touch, refer to the "NAVIGATION AND MULTI-MEDIA SYSTEM OWNER'S MANUAL".

■ When customizing using the Remote Touch

Stop the vehicle in a safe place, apply the parking brake, and shift the shift lever to P. Also, to prevent battery discharge, leave the engine running while customizing the features.

WARNING

■ Cautions during customization

As the engine needs to be running during customization, ensure that the vehicle is parked in a place with adequate ventilation. In a closed area such as a garage, exhaust gases including harmful carbon monoxide (CO) may collect and enter the vehicle. This may lead to death or a serious health hazard.

NOTICE

■ During customization

To prevent battery discharge, ensure that the engine is running while customizing features.

Customizable features

Some function settings are changed simultaneously with other functions being customized. Contact any authorized Lexus retailer or Lexus authorized repairer, or any reliable repairer for further details.

A Settings that can be changed using the Remote Touch

B Settings that can be changed using the meter control switches

C Settings that can be changed by any authorized Lexus retailer or Lexus authorized repairer, or any reliable repairer

Definition of symbols: ○ = Available, — = Not available

■ Alarm (→P.97)

Function	Default setting	Customized setting	A	B	C
Cancellation when the mechanical key is used to unlock	Off	On	—	—	○

■ Gauges, meters and multi-information display (→P.108, 111, 115)

Function ^{*1}	Default setting	Customized setting	A	B	C
Language ^{*2}	English	French	—	○	—
		German			
		Spanish			
		Italian			
		Russian			
		Dutch			
		Turkish			
Units ^{*2}	km (L/100 km)	km (km/L)	○	○	—
		miles (MPG) ^{*3}			
Speedometer display ^{*4}	Digital	Analog	—	○	—
Drive information 1	Current fuel consumption	^{*5}	—	○	—
	Average fuel economy (after reset)				

Function ^{*1}	Default setting	Customized setting	A	B	C
Drive information 2	Distance (driving range)	*5	—	○	—
	Average vehicle speed (after reset)		—	○	—
Clock	24-hour display	12-hour display	—	○	—
Pop-up display	On	Off	—	○	—
Accent color	Color 1	Color 2	○	○	—
Rev indicator ^{*6}	On	Off	—	○	—
Rev indicator red zone setting ^{*6}	5000 r/min.	2000-6800r/min.	—	○	—
Rev peak ^{*6}	On	Off	—	○	—
Eco Driving Indicator Light	On	Off	—	○	—
Suggestion function	On	On (when the vehicle is stopped)	○	—	○
		Off	○	—	○

*1: For details about each function: →P.108, 111, 120

*2: The default setting varies according to country.

*3: The customized setting varies according to country.

*4: Except F SPORT models

*5: 2 of the following items: current fuel consumption, average fuel economy (after reset), average fuel economy (after start), average fuel economy (after refuel), average vehicle speed (after reset), average vehicle speed (after start), elapsed time (after reset), elapsed time (after start), distance (driving range), distance (after start), blank.

*6: F SPORT models

■ Head-up Display ^{*} (→P.122)

Function	Default setting	Customized setting	A	B	C
Gauge information	Tachometer	Eco Driving Indicator	—	○	—
		No content	—	○	—

Function	Default setting	Customized setting	A	B	C
Route guidance to destination/street name *	On	Off	—	○	—
Driving support system display	On	Off	—	○	—
Compass *	On	Off	—	○	—
Audio system operation status	On	Off	—	○	—

*: If equipped

■ Door lock (→P.134, 480)

Function	Default setting	Customized setting	A	B	C
Unlocking using a mechanical key	All doors unlocked in one step	Driver's door unlocked in one step, all doors unlocked in two step	—	—	○
Speed linked door locking function	On	Off	○	—	○
Shift position linked door locking function	Off	On	○	—	○
Shift position linked door unlocking function	Off	On	○	—	○
Driver's door linked door unlocking function	On	Off	○	—	○

■ Smart entry & start system * and wireless remote control (→P.132, 151)

Function	Default setting	Customized setting	A	B	C
Time elapsed before automatic door lock function is activated if door is not opened after being unlocked	30 seconds	60 seconds	—	—	○
		120 seconds			
Open door warning buzzer	On	Off	—	—	○

*: If equipped

■ Smart entry & start system* (→P.151)

Function	Default setting	Customized setting	A	B	C
Smart entry & start system	On	Off	<input type="radio"/>	—	<input type="radio"/>
Smart door unlocking	All the doors	Driver's door	<input type="radio"/>	—	<input type="radio"/>
Time elapsed before unlocking all the door when gripping and holding the driver's door handle	2 seconds	Off			<input type="radio"/>
		1.5 seconds	—	—	<input type="radio"/>
		2.5 seconds			
Number of consecutive door lock operations	As many as desired	2 times	—	—	<input type="radio"/>

*: If equipped

■ Wireless remote control (→P.132)

Function	Default setting	Customized setting	A	B	C
Wireless remote control	On	Off	—	—	<input type="radio"/>
Unlocking operation	All doors unlocked in one step	Driver's door unlocked in one step, all doors unlocked in two step	<input type="radio"/>	—	<input type="radio"/>
The function that activates the  switch of the wireless remote control when locking the door (→P.141)*	Off	On (Unlocking all the door)	—	—	<input type="radio"/>
		On (Unlocking back door only)			

*: If equipped

■ Power back door*¹(→P.141)

Function	Default setting	Customized setting	A	B	C
Power back door opening position	5	1 to 4	<input type="radio"/>	—	—
Power back door operation	On	Off	—	<input type="radio"/>	—

Function	Default setting	Customized setting	A	B	C
Buzzer volume	Level 3	Level 1	—	○	—
		Level 2	—	○	—
Operation buzzer	Off	On	—	—	○
Hands Free Power Back Door (kick sensor)	On	Off	—	○	○
Hands Free Power Back Door (kick sensor) when the engine switch is OFF ^{*1,2}	On	Off	—	—	○

*1: If equipped

*2: When the towing hitch is installed, Hands Free Power Back Door (kick sensor) does not work.

■ Driving position memory* (→P.187)

Function	Default setting	Customized setting	A	B	C
Selecting doors linked to the memory recall function	Driver's door	All doors	—	—	○
Driver's seat slide movement when exiting the vehicle	Full	Off	○	—	○
		Partial	○	—	○
Steering wheel movement	Tilt only	Off	○	—	○
		Telescopic only	○	—	○
		Tilt and telescopic	○	—	○

*: If equipped

■ Outside rear view mirrors (→P.195)

Function	Default setting	Customized setting	A	B	C
Automatic mirror folding and extending operation*	Linked to the locking/ unlocking of the doors	Off	—	—	○
		Linked to operation of the engine switch	—	—	○

*: If equipped

■ Power windows and moon roof* (→P.197, 199)

Function	Default setting	Customized setting	A	B	C
Mechanical key linked operation	Off	On	—	—	○
Wireless remote control linked operation	Off	On	—	—	○
Wireless remote control linked operation signal (buzzer)	On	Off	—	—	○

*: If equipped

■ Automatic light control system (→P.231)

Function	Default setting	Customized setting	A	B	C
Light sensor sensitivity	Standard	-2 to 2	○	—	○
Follow me home (Time elapsed before headlights automatically turn off)	30 seconds	60 seconds	—	—	○
		90 seconds			
		120 seconds			

■ Lights (→P.231)

Function	Default setting	Customized setting	A	B	C
Welcome lighting	On	Off	—	—	○

■ Rear window wiper (→P.245)

Function	Default setting	Customized setting	A	B	C
Rear window wiper operation when the back door is opened	On	Off	—	—	○
Washer linked rear window wiper operation	On	Off	—	—	○
Shift position linked rear window wiper operation	Once	Off	—	—	○
		Continuous			

■ AHS (Adaptive High-beam System)^{*1}(→P.233)

Function	Default setting	Customized setting	A	B	C
Adaptive High-beam System	On	Off ^{*2}	—	—	○
Clearance between a vehicle ahead and the shaded high beams	Wide	Narrow	—	—	○
		Standard	—	—	○
Brightness and illuminated area adjustment of the high beams according to the vehicle speed	Operates at approximately 15 km/h (10 mph) or more	Operates at approximately 30 km/h (19 mph) or more	—	—	○
		Operates at approximately 80 km/h (50 mph) or more	—	—	○
Intensity adjustment of the high beams when driving around a curve (illuminates the area in the direction vehicle is turning more brightly)	On	Off	—	—	○
Projection distance adjustment of the low beams according to the distance to a preceding vehicle	On	Off	—	—	○
Illumination of the cornering lights when starting off	On	Off	—	—	○
High beam light distribution control for rain	On	Off	—	—	○
Light distribution control for urban areas	On	Off	—	—	○

^{*1}: If equipped

^{*2}: The headlights will operate under Automatic High Beam control. (→P.237)

■ **PCS (Pre-Collision System)*** (→P.260)

Function	Default setting	Customized setting	A	B	C
PCS (Pre-Collision System)	On	Off	—	<input type="radio"/>	—
Adjust alert timing	Middle	Far	—	<input type="radio"/>	—
		Near	—	<input type="radio"/>	—

*: If equipped

■ **LTA (Lane Tracing Assist)*** (→P.268)

Function	Default setting	Customized setting	A	B	C
Lane centering function	On	Off	—	<input type="radio"/>	—
Steering assist function	On	Off	—	<input type="radio"/>	—
Alert type	Steering wheel vibration	Buzzer	—	<input type="radio"/>	—
Alert sensitivity	High	Standard	—	<input type="radio"/>	—
Vehicle sway warning function	On	Off	—	<input type="radio"/>	—
Vehicle sway warning sensitivity	Standard	High	—	<input type="radio"/>	—
		Low	—	<input type="radio"/>	—

*: If equipped

■ **RSA (Road Sign Assist)*¹** (→P.277)

Function	Default setting	Customized setting	A	B	C
RSA (Road Sign Assist)	On	Off	—	<input type="radio"/>	—
Excess speed notification method	No notification	Display only	—	<input type="radio"/>	—
		Display and buzzer	—	<input type="radio"/>	—
Excess speed notification level	2 km/h (1 mph)	10 km/h (5 mph)	—	<input type="radio"/>	—
		5 km/h (3 mph)	—	<input type="radio"/>	—
No overtaking notification method	Display only	No notification	—	<input type="radio"/>	—
		Display and steering wheel vibration	—	<input type="radio"/>	—

Function	Default setting	Customized setting	A	B	C
Other notifications method* ²	Display only	No notification	—	○	—
		Display and buzzer			

*¹: If equipped

*²: Including no-entry notification (vehicles with navigation system)

■ **Dynamic radar cruise control with full-speed range*** (→P.281)

Function	Default setting	Customized setting	A	B	C
Dynamic Radar Cruise Control with Road Sign Assist*	Off	On	—	○	—

*: If equipped

■ **Stop & Start system** (→P.294)

Function	Default setting	Customized setting	A	B	C
Change the Stop & Start system duration when the A/C is on	Standard	Extended	—	○	—

■ **BSM (Blind Spot Monitor)*** (→P.301)

Function	Default setting	Customized setting	A	B	C
BSM (Blind Spot Monitor)	On	Off	—	○	—
Outside rear view mirror indicator brightness	Bright	Dim	—	○	—
Alert timing for presence of approaching vehicle (sensitivity)	Intermediate	Early	—	○	—
		Late			
		Only when vehicle detected in blind spot			

*: If equipped

■ PKSA (Parking Support Alert)* (→P.312)

Function	Default setting	Customized setting	A	B	C
Buzzer volume	Level 2	Level 1	—	○	—
		Level 3	—	○	—

*: If equipped

■ Lexus parking assist-sensor* (→P.313)

Function	Default setting	Customized setting	A	B	C
Lexus parking assist-sensor	On	Off	—	○	—

*: If equipped

■ RCTA (Rear Crossing Traffic Alert) function* (→P.320)

Function	Default setting	Customized setting	A	B	C
RCTA (Rear Crossing Traffic Alert) function	On	Off	—	○	—

*: If equipped

■ PKSB (Parking Support Brake)* (→P.324)

Function	Default setting	Customized setting	A	B	C
PKSB (Parking Support Brake) function	On	Off	—	○	—

*: If equipped

■ Driving mode select switch (→P.337)

Function	Default setting	Customized setting	A	B	C
Powertrain control in Custom mode*	Normal	Power	○	—	—
		Eco	○	—	—

Function	Default setting	Customized setting	A	B	C
Chassis control in Custom mode*	Normal	Sport	<input type="radio"/>	—	—
Air conditioning operation in Custom mode*	Normal	Eco	<input type="radio"/>	—	—

*: If equipped

■ Automatic air conditioning system (→P.356)

Function	Default setting	Customized setting	A	B	C
Switching between outside air and recirculated air mode linked to "AUTO" switch operation	On	Off	<input type="radio"/>	—	<input type="radio"/>
A/C auto switch operation	On	Off	<input type="radio"/>	—	<input type="radio"/>

■ Seat heater* /seat ventilators* (→P.365)

Function	Default setting	Customized setting	A	B	C
Driver's seat temperature preference in automatic mode	Standard	-2 (cooler) to 2 (warmer)	<input type="radio"/>	—	<input type="radio"/>
Passenger's seat temperature preference in automatic mode	Standard	-2 (cooler) to 2 (warmer)	<input type="radio"/>	—	<input type="radio"/>

*: If equipped

■ Heated steering wheel* (→P.365)

Function	Default setting	Customized setting	A	B	C
Steering wheel heating preference in automatic mode	Standard	-2 (low) to 2 (high)	<input type="radio"/>	—	<input type="radio"/>

*: If equipped

■ Illumination (→P.369)

Function	Default setting	Customized setting	A	B	C
Time elapsed before the interior lights turn off	15 seconds	Off			
		7.5 seconds	○	—	○
		30 seconds			
Operation after the engine switch is turned off	On	Off	—	—	○
Operation when the doors are unlocked	On	Off	—	—	○
Operation when you approach the vehicle with the electronic key on your person	On	Off	—	—	○
Footwell lights	On	Off	—	—	○
Time elapsed before the interior lights turn off	15 seconds	Off			
		7.5 seconds	○	—	○
		30 seconds			
Outside door handle lights	On	Off	—	—	○
Time elapsed before the outside door handle lights turn off	15 seconds	Off			
		7.5 seconds	○	—	○
		30 seconds			
Operation of the outside door handle lights when you approach the vehicle with the electronic key on your person	On	Off	—	—	○
Operation of the outside door handle lights when the doors are unlocked	On	Off	—	—	○
Operation of the outside door handle lights when a door is opened	On	Off	—	—	○

Function	Default setting	Customized setting	A	B	C
Rear interior light and footwell lights	On	Off	—	—	○
Fading out of the outside door handle lights when they turn off	Long	Short	—	—	○

■ **Vehicle customization**

- When the speed linked door locking function and shift position linked door locking function are both on, the door lock operates as follows.
 - When shifting the shift lever to any position other than P, all the doors will be locked.
 - If the vehicle is started with all the doors locked, the speed linked door locking function will not operate.
 - If the vehicle is started with any door unlocked, the speed linked door locking function will operate.
- When the smart entry & start system is off, the entry unlock function cannot be customized.
- When the doors remain closed after unlocking the doors and the timer activated automatic door lock function activates, signals will be generated in accordance with the operational signal (Emergency flashers) function setting.
- Some settings can be changed using a switch or the Center Display. If a setting is changed using a switch, the changed setting will not be reflected on the Center Display until the engine switch is turned off and then to ON.

■ **Clock settings screen**

If the clock adjustment screen is displayed continuously when attempting to change the clock settings, the system may be malfunctioning. Have the vehicle inspected by any authorized Lexus retailer or Lexus authorized repairer, or any reliable repairer.

Items to initialize

The following item must be initialized for normal system operation after such cases as the battery being reconnected, or maintenance being performed on the vehicle:

List of the items to initialize

Item	When to initialize	Reference
PKSB (Parking Support Brake)*	<ul style="list-style-type: none"> After reconnecting or changing the battery 	P.328
Tire pressure warning system	<ul style="list-style-type: none"> When rotating the tires When the tire inflation pressure is changed by changing tire size. (When there are multiple specified pressures) After registering the ID codes 	P.420
Oil maintenance	<ul style="list-style-type: none"> After the maintenance is performed 	P.404
Lexus parking assist monitor*	<ul style="list-style-type: none"> Battery has been reinstalled The steering wheel has been moved while the battery was being reinstalled Battery power is low 	Refer to "NAVIGATION AND MULTIMEDIA SYSTEM OWNER'S MANUAL".
Panoramic view monitor*		
Power back door*	<ul style="list-style-type: none"> After reconnecting or changing the battery After changing a fuse 	P.146
Power window	<ul style="list-style-type: none"> When functioning abnormally 	P.197
Moon roof*		P.200

*: If equipped

Index

517

What to do if... (Troubleshooting)

..... **518**

Alphabetical Index **521**

What to do if... (Troubleshooting)

If you have a problem, check the following before contacting any authorized Lexus retailer or Lexus authorized repairer, or any reliable repairer.

The doors cannot be locked, unlocked, opened or closed



You lose your keys

- If you lose your mechanical keys, new genuine mechanical keys can be made by any authorized Lexus retailer or Lexus authorized repairer, or any reliable repairer. (→P.479)
- If you lose your electronic keys, the risk of vehicle theft increases significantly. Contact any authorized Lexus retailer or Lexus authorized repairer, or any reliable repairer immediately. (→P.479)



The doors cannot be locked or unlocked

- Is the electronic key battery weak or depleted? (→P.428)
- Vehicles with entry function
Is the engine switch in ON?
When locking the doors, turn the engine switch off. (→P.219)
- Vehicles with entry function

Is the electronic key left inside the vehicle?

When locking the doors, make sure that you have the electronic key on your person.

- The function may not operate properly due to the condition of the radio wave. (→P.153)



The rear door cannot be opened

- Is the child-protector lock set?
The rear door cannot be opened from inside the vehicle when the lock is set. Open the rear door from outside and then unlock the child-protector lock. (→P.137)

If you think something is wrong



The engine does not start

- Did you press the engine switch while firmly depressing the brake pedal? (→P.217)
- Is the shift lever in P? (→P.217)
- Is the electronic key anywhere detectable inside the vehicle? (→P.151)
- Is the steering wheel unlocked? (→P.218)
- Is the electronic key battery weak or depleted?

In this case, the engine can be started in a temporary way.
(→P.481)

- Is the battery discharged?
(→P.482)

 **The shift lever cannot be shifted from P even if you depress the brake pedal**

- Is the engine switch in ON?
If you cannot release the shift lever by depressing the brake pedal with the engine switch in ON (→P.222)

 **The steering wheel cannot be turned after the engine is stopped**

- It is locked automatically to prevent theft of the vehicle. (→P.218)

 **The windows do not open or close by operating the power window switches**

- Is the window lock switch pressed?
The power window except for the one at the driver's seat cannot be operated if the window lock switch is pressed. (→P.199)

 **The engine switch is turned off automatically**

- The auto power off function will be operated if the vehicle is left in ACC or ON (the engine is not running) for a period of time. (→P.219)

 **A warning buzzer sounds during driving**

- The seat belt reminder light is flashing
Are the driver and the passengers wearing the seat belts? (→P.448, 449)
- The parking brake indicator is on
Is the parking brake released?
(→P.225)

Depending on the situation, other types of warning buzzer may also sound. (→P.444, 452)

 **An alarm is activated and the horn sounds (vehicles with alarm)**

- Did anyone inside the vehicle open a door during setting the alarm?
The sensor detects it and the alarm sounds. (→P.97)

To stop the alarm, turn the engine switch to ON or start the engine.

 **A warning buzzer sounds when leaving the vehicle**

- Is the message displayed on the multi-information display?
Check the message on the multi-information display. (→P.452)

 **A warning light turns on or a warning message is displayed**

- When a warning light turns on or a

warning message is displayed, refer to P.444, 452.

When a problem has occurred



If you have a flat tire

- Vehicles with emergency tire puncture repair kit:
Stop the vehicle in a safe place and repair the flat tire temporarily with the emergency tire puncture repair kit. (→P.455)
- Vehicles with spare tire:
Stop the vehicle in a safe place and replace the flat tire with the spare tire. (→P.467)
- Vehicles with run-flat tires:
Slow down the vehicle, drive with extra caution, and take your vehicle to the nearest authorized Lexus retailer or Lexus authorized repairer, or any reliable repairer, or authorized tire dealer as soon as possible to have the tire replaced. (→P.476)



The vehicle becomes stuck

- Try the procedure for when the vehicle becomes stuck in mud, dirt, or snow. (→P.487)

Alphabetical Index

A

- A/C..... 356
 - "DUAL" mode.....363
 - Air conditioning filter.....426
 - Automatic air conditioning system...356
 - Blower customization361
 - S-FLOW mode.....363
- ABS (Anti-lock Brake System) 339
 - Function339
 - Warning light446
- ACA(Active Cornering Assist)..... 340
- Active Cornering Assist (ACA)..... 340
- Active Sound Control/Acceleration Sound Control (ASC)..... 230
- Adaptive High-beam System (AHS)...233
- Adaptive Variable Suspension system (AVS)..... 340
- AHS (Adaptive High-beam System)...233
 - Warning message.....452
- Airbag manual on-off system.....47
- Airbags..... 38
 - Airbag manual on-off system 47
 - Airbag operating conditions.....40
 - Airbag precautions for your child..... 42
 - Correct driving posture33
 - Curtain shield airbag operating conditions.....40
 - Curtain shield airbag precautions..... 42
 - General airbag precautions 42
 - Locations of airbags.....38
 - Modification and disposal of airbags. 45
 - Side airbag operating conditions 40
 - Side airbag precautions 42
 - Side and curtain shield airbags operating conditions.....40
 - Side and curtain shield airbags precautions..... 42
 - SRS airbags38
 - SRS warning light.....446
- Air conditioning filter.....426
- Air conditioning system..... 356
 - "DUAL" mode..... 363
 - Air conditioning filter.....426
 - Automatic air conditioning system.. 356
 - Blower customization..... 361
 - S-FLOW mode..... 363
- Alarm
 - Alarm.....97
 - Warning buzzer444
- Antenna (smart entry & start system)... 151
- Anti-lock Brake system (ABS)..... 339
 - Function 339
- Anti-lock Brake System (ABS)
 - Warning light446
- Approach warning281
 - Road Sign Assist.....287
- Armrest.....387
- ASC (Active Sound Control/Acceleration Sound Control)..... 230
- Assist grips.....387
- Audio system-linked display120
- Automatic air conditioning system..... 356
 - Blower customization..... 361
- Automatic headlight leveling system...232
- Automatic High Beam
 - Automatic High Beam237
 - Warning message.....452
- Automatic light control system 231
- Average fuel economy117
- Average vehicle speed.....117
- AVS (Adaptive Variable Suspension system)..... 340

B

- Back door.....138
 - Back door closer..... 144
 - Back door opener switch..... 140
 - Hands Free Power Back Door 143
 - Luggage compartment light140, 144

- Power back door opener and closer switch.....142
 - Power back door switch.....142
 - Power back door.....141
 - Wireless remote control.....132, 140
 - Back-up lights**
 - Replacing light bulbs.....432
 - Battery**.....406
 - If the battery is discharged.....482
 - Preparing and checking before winter.....344
 - Replacing.....484
 - Warning light.....444
 - Blind Spot Monitor (BSM)**.....301
 - Function.....310
 - Warning message.....301
 - Bottle holders**.....374
 - Brake**
 - Brake Hold.....228
 - Fluid.....496
 - Parking brake.....225
 - Warning light.....444, 446
 - Brake assist**.....339
 - Brake Hold**.....228
 - Break-in tips**.....205
 - Brightness control**
 - Instrument panel light control.....110, 114
 - BSM (Blind Spot Monitor)**.....301
 - Function.....310
 - Warning message.....301
- C**
- Card key**.....130
 - Care**
 - Aluminum wheels.....391
 - Exterior.....390
 - Interior.....393
 - Seat belts.....393
 - Self-restoring coat.....390
 - Cargo hooks**.....375
 - Center Display**.....350
 - Chains**
 - Tire chains.....346
 - Child-protectors**.....137
 - Child restraint system**.....49
 - Child seats definition.....49
 - Child seats installation.....53
 - Installing a CRS to a front passenger seat.....50
 - Installing CRS with an ISOFIX lower anchorage.....61
 - Installing CRS with seat belts.....59
 - Points to remember.....49
 - Riding with children.....48
 - Types of child restraint system installation method.....59
 - Using a top tether anchorage.....62
 - Child safety**.....48
 - Airbag manual on-off system.....47
 - Airbag precautions.....42
 - Back door precautions.....138
 - Battery precautions.....407, 484
 - Child restraint system.....49
 - How your child should wear the seat belt.....35
 - Installing child restraints.....49
 - Moon roof precautions.....201
 - Power window lock switch.....199
 - Power window precautions.....198
 - Rear door child-protectors.....137
 - Removed key battery precautions...429
 - Riding with children.....48
 - Seat belt precautions.....48
 - Seat heater precautions.....365
 - Cleaning**.....390, 393
 - Aluminum wheels.....391
 - Exterior.....390
 - Interior.....393
 - Radar sensor.....250
 - Seat belts.....393
 - Clock**.....108, 111, 380

Coat hooks387
 Coin holder374
 Condenser.....405
 Console box.....373
 Consumption screen.....126
 Coolant
 Capacity494
 Checking404
 Preparing and checking before winter
 344
 Cooling system404
 Engine overheating485
 Cornering lights.....233
 Cruise control
 Cruise control292
 Dynamic radar cruise control with full-
 speed range.....281
 Cup holders.....373
 Current fuel consumption.....117
 Curtain shield airbags38
 Customizable features501

D

Daytime running lights
 Replacing light bulbs.....432
 Daytime running light system.....231
 Deck board.....376
 Deck under tray.....375
 Defogger
 Outside rear view mirrors.....357
 Rear window357
 Windshield.....357
 Dimension.....490
 Display
 BSM (Blind Spot Monitor)301
 Center Display.....126, 351
 Cruise control292
 Dynamic radar cruise control with full-
 speed range.....281
 Fuel consumption information126

Head-up display122
 Lexus parking assist-sensor313
 LTA (Lane Tracing Assist).....273
 Multi-information display115
 PKSB (Parking Support Brake) system
 325
 RCTA (Rear Crossing Traffic Alert) func-
 tion.....320
 Warning messages.....452
 Distance until next engine oil change.109,
 114
 Do-it-yourself maintenance.....398
 Door lock
 Doors134
 Smart entry & start system151
 Wireless remote control132
 Doors
 Automatic door locking and unlocking
 system.....137
 Back door138
 Door lock134
 Open door warning buzzer.....135, 137
 Outside rear view mirrors.....195
 Rear door child-protectors.....137
 Side doors134
 Double locking system96
 Drive distance.....117
 Drive info 1/Drive info 2117
 Driver's seat position memory.....187
 Memory recall function.....188
 Power easy access system187
 Drive-start control205
 Driving
 Break-in tips.....205
 Correct driving posture33
 Driving mode select switch337
 Preparing and checking before winter
 344
 Procedures.....204
 Driving information display.....117
 Driving position memory187

Memory recall function 188
 Power easy access system 187
Driving range 117
Driving support system information display
 120
 “DUAL” mode 363
Dynamic radar cruise control with full-
speed range 281
 Road Sign Assist (RSA) 289
 Warning message 452

E

eCall 64
Eco drive mode 337
Eco Driving Indicator 118, 126
Eco Driving Indicator Light 118
Elapsed time 117
Electric Power Steering (EPS)
 Function 340
 Warning light 446
Electronic key 130
 Battery-saving function 152
 If the electronic key does not operate
 properly 480
 Replacing the battery 428
Emergency, in case of
 If a warning buzzer sounds 444
 If a warning light turns on 444
 If a warning message is displayed 452
 If the battery is discharged 482
 If the electronic key does not operate
 properly 480
 If the engine will not start 477
 If the fuel filler door cannot be opened
 479
 If the vehicle is trapped in rising water
 437
 If you have a flat tire 455, 467, 476
 If you lose your keys 479
 If you think something is wrong 442

 If your vehicle becomes stuck 487
 If your vehicle has to be stopped in an
 emergency 436
 If your vehicle needs to be towed 439
 If your vehicle overheats 485
Emergency brake signal 340
Emergency flashers 436
Emergency tire puncture repair kit 455
Engine
 ACC 219
 Compartment 402
 Engine switch 217
 Fuel pump shut off system 443
 Hood 400
 How to start the engine 217
 Identification number 491
 If the engine will not start 477
 If your vehicle has to be stopped in an
 emergency 436
 Ignition switch (Engine switch) 217
 Overheating 485
 Tachometer 108, 111
Engine coolant
 Capacity 494
 Checking 404
 Preparing and checking before winter
 344
Engine coolant temperature gauge 108, 111
Engine immobilizer system 84
Engine oil 344
 Capacity 493
 Checking 402
 Warning light 444
Engine oil maintenance data 404
Engine switch 217
 Auto power off function 219
 Changing engine switch modes 219
 If your vehicle has to be stopped in an
 emergency 436
 Starting the engine 217

EPS (Electric Power Steering)
 Function 340
 Warning light 446
 ERA-GLONASS/EVAK 80
 Exhaust Gas Filter system 339
 Exhaust gas precautions 45

F

Flat tire 455, 467, 476
 Tire pressure warning system 411
 Floor mats 32
 Fluid
 Brake 496
 Multidrive 495
 Washer 408
 Fog lights
 Replacing light bulbs 432
 Switch 239
 Follow me home system 232
 Footwell lights 369
 Front fog lights
 Switch 239
 Front position lights
 Replacing light bulbs 432
 Switch 231
 Welcome light illumination control .. 232
 Front seats
 Adjustment 184
 Cleaning 393
 Correct driving posture 33
 Driving position memory 187
 Head restraints 190
 Memory recall function 188
 Power easy access system 187
 Seat heaters 365
 Seat position memory 187
 Seat ventilators 366
 Front turn signal lights
 Replacing light bulbs 432, 433
 Turn signal lever 224

Wattage 498
 Fuel 247
 Capacity 492
 Fuel gauge 108, 111
 Fuel pump shut off system 443
 Information 499
 Refueling 247
 Type 492
 Warning light 448
 Fuel consumption
 Average fuel economy 117
 Current fuel consumption 117
 Fuel consumption information 126
 Fuel filler door 247
 If the fuel filler door cannot be opened
 479
 Refueling 247
 Fuel gauge 108, 111
 Fuel pump shut off system 443
 Fuses 430

G

Gauges 108, 111
 G-force 119
 Glove box 373
 Glove box light 373
 Grocery bag hooks 375

H

Hands Free Power Back Door 143
 Headlight cleaners 241
 Headlights 231
 AHS (Adaptive High-beam System) 233
 Automatic High Beam 237
 Cornering lights 233
 Follow me home system 232
 Light switch 231
 Replacing light bulbs 432
 Head restraints 190

Head-up display 122
 Driving information display area 122
 Driving support system display area 125
 Eco Driving Indicator 126
 HUD (Head-up display) switch 124
 Navigation system-linked display 122
 Pop-up display 125
 Settings 124
Heated steering wheel 365
Heaters
 Automatic air conditioning system 356
 Heated steering wheel 366
 Outside rear view mirrors 357
 Seat heaters 365
Hill-start assist control 340
Hood
 Hood 400
 Open 400
 Warning message 452
Hooks
 Cargo hooks 375
 Coat hooks 387
 Grocery bag hooks 375
 Retaining hooks (floor mat) 32
Horn 193
HUD (Head-up display) switch 124

I

Identification
 Engine 491
 Vehicle 491
Ignition switch (Engine switch) 217
 Auto power off function 219
 Changing engine switch modes 219
 If your vehicle has to be stopped in an
 emergency 436
 Starting the engine 217
Illuminated entry system 369
Indicators 106

Initialization
 Engine oil maintenance data 404
 Items to initialize 515
 Moon roof 200
 Power window 197
 Tire pressure warning system 420
Inside rear view mirror 193
Instrument panel light control 110, 114
Interior lights 369
Intrusion sensor 99
Intrusion sensor and tilt sensor 99
ISOFIX lower anchorage 61

J

Jack
 Positioning a floor jack 401
 Vehicle-equipped jack 375, 457, 468
Jack handle 375, 457, 468
Jam protection function
 Front seats 184
 Moon roof 200
 Power back door 146
 Power windows 197

K

Keyless entry
 Smart entry & start system 151
 Wireless remote control 132
Keys 130
 Battery-saving function 152
 Card key 130
 Electronic key 130
 Engine switch 217
 If the electronic key does not operate
 properly 480
 If you lose your keys 479
 Key number plate 130
 Keyless entry 132, 151
 Mechanical key 130
 Replacing the battery 428

Warning buzzer152
 Wireless remote control.....132
Knee airbags 38

L

Lane Tracing Assist (LTA)..... 268
 Function271
 Operation.....268
 Warning messages..... 277, 452
Language (multi-information display).. 120
Lever
 Auxiliary catch lever 400
 Hood lock release lever 400
 Shift lever.....221
 Turn signal lever 224
 Wiper lever.....245
Lexus climate concierge..... 350
Lexus parking assist-sensor
 Function313
 Warning message.....316
Lexus Safety System+249
 AHS (Adaptive High-beam System)233
 Automatic High Beam..... 237
 Dynamic radar cruise control with full-
 speed range..... 281
 LTA (Lane Tracing Assist).....268
 PCS (Pre-Collision System).....260
 RSA (Road Sign Assist).....277
License plate lights 231
 Light switch.....231
 Replacing light bulbs..... 432
Light bulbs
 Replacing.....432
 Wattage..... 498
Lights
 AHS (Adaptive High-beam System)233
 Automatic High Beam..... 237
 Cornering lights233
 Fog light switch239
 Follow me home system232

Front interior lights370
 Front personal lights.....371
 Headlight switch.....231
 Illuminated entry system 369
 Interior light list 369
 Luggage compartment light 140, 144
 Rear interior lights.....370
 Rear personal lights.....371
 Replacing light bulbs.....432
 Turn signal lever 224
 Vanity lights.....380
 Wattage.....498
 Welcome light illumination control..232
LTA (Lane Tracing Assist)..... 268
 Function271
 Operation.....268
 Warning messages..... 277, 452
Luggage cover.....377

M

Maintenance
 Do-it-yourself maintenance.....398
 Maintenance data.....490
 Maintenance requirements.....396
Malfunction indicator lamp.....445
Mechanical key.....130
Menu icons116
Meter
 Changing the main meter location.....115
 Clock.....108, 111
 Indicators.....106
 Instrument panel light control..... 110, 114
 Meter control switches 117
 Meters.....108, 111
 Multi-information display115
 Settings.....120
 Warning lights444
 Warning messages.....452
Mirrors
 Inside rear view mirror193

Outside rear view mirror defoggers 357
 Outside rear view mirrors..... 195
 Vanity mirrors..... 380

Moon roof
 Door lock linked moon roof operation
 200
 Jam protection function..... 200
 Operation..... 199
 Warning message..... 452

Multidrive 220
 If the shift lever cannot be shifted from P
 222
 M position..... 223
 Paddle shift switches..... 222, 223

Multi-information display..... 115
 Audio system-linked display..... 120
 BSM (Blind Spot Monitor)..... 301
 Drive information 1/Drive information 2
 117
 Driving information display..... 117
 Driving support system information display
 120
 Dynamic radar cruise control with full-
 speed range..... 281
 Eco Driving Indicator 118, 126
 G-force..... 119
 Lexus parking assist-sensor..... 313
 LTA (Lane Tracing Assist)..... 273
 Menu icons..... 116
 Meter control switches..... 117
 Navigation system-linked display 120
 Pop-up display..... 115
 Settings..... 120
 Stop & Start system information..... 118
 Stop & Start system..... 298
 Suggestion function..... 121
 Tire pressure..... 411
 Warning messages..... 452

N

nanoe™..... 361
 Navigation system-linked display 120, 122

O

Odometer 109, 114
Odometer and trip meter display
 "ODO TRIP" switch..... 110, 114
 Display items..... 109, 114
 Pop-up display..... 110, 114
 "ODO TRIP" switch..... 110, 114

Oil
 Engine oil..... 493

Opener
 Back door..... 140
 Fuel filler door..... 247
 Hood..... 400

Outside door handle lights 369
Outside rear view mirrors..... 195
 Adjustment..... 195
 BSM (Blind Spot Monitor)..... 301
 Folding and extending..... 196
 Linked mirror function when reversing
 196
 Mirror position memory..... 187
 Outside rear view mirror defoggers 357
 RCTA (Rear Crossing Traffic Alert) func-
 tion..... 320

Outside temperature 108, 111
Overheating..... 485

P

Paddle shift switches..... 222, 223
**Parking assist sensors (Lexus parking
 assist-sensor)**..... 313
Parking brake
 Operation..... 225
 Parking brake engaged warning buzzer
 227

Warning light..... 447
 Warning message.....227
Parking Support Brake function (for rear-crossing vehicles) 333
 Function..... 333
Parking Support Brake function (static objects)..... 328
 Function..... 328
Parking Support Brake function
 Warning message..... 327
PCS (Pre-Collision System)..... 260
 Function.....260
 PCS OFF switch.....262
 Warning light..... 450
 Warning messages.....452
Personal lights 369
PKSA (Parking Support Alert)..... 312
PKSA (Parking Support Alert) system
 Lexus parking assist-sensor.....312
 RCTA (Rear Crossing Traffic Alert)..312
PKSB (Parking Support Brake).....324
PKSB (Parking Support Brake) system
 Parking Support Brake function (rear-crossing vehicles)..... 324
 Parking Support Brake function (static objects)..... 324
Power back door.....141
 Jam protection function.....146
 Power back door switch.....142
Power back door opener and closer.... 142
Power back door switch 142
Power easy access system.....187
Power outlet.....381
Power steering (Electric Power Steering system) 340
Power steering (Electric power steering system)
 Warning light.....446
Power windows
 Door lock linked window operation.198
 Jam protection function.....197

Operation..... 197
 Window lock switch.....199
Pre-Collision System (PCS)..... 260
 Function..... 260
 PCS OFF switch262
 Warning light.....450
 Warning messages.....452

R

Radar cruise control (dynamic radar cruise control with full-speed range) 281
Radiator..... 405
RCTA (Rear Crossing Traffic Alert).. 320
 Warning message.....321
RCTA
 Function.....321
 RCTA.....320
 Warning message.....321
RCTA function..... 321
Rear Crossing Traffic Alert (RCTA).. 320
Rear door child-protectors..... 137
Rear fog lights
 Switch.....239
Rear seat
 Folding down the rear seatbacks.....185
Rear turn signal lights
 Replacing light bulbs.....432
 Turn signal lever224
Rear view mirror
 Inside rear view mirror193
 Outside rear view mirrors.....195
Rear window defogger.....357
Rear window wiper245
Rear window wiper and washer245
Refueling.....247
 Capacity.....492
 Fuel types.....492
 If the fuel filler door cannot be opened
479
 Opening the fuel tank cap.....247

- Remote Touch..... 350
 - Replacing
 - Electronic key battery.....428
 - Fuses.....430
 - Light bulbs.....432
 - Tires.....455, 467, 476
 - Rev indicator.....113
 - Rev peak.....113
 - Road Sign Assist (RSA).....277
 - RSA (Road Sign Assist).....277
 - Warning message.....452
 - Run-flat tires.....411, 476
- S**
- Seat belt reminder lights.....448, 449
 - Seat belts.....34
 - Adjusting the seat belt shoulder anchor height.....36
 - Child restraint system installation.....49
 - Cleaning and maintaining the seat belt.....393
 - Emergency Locking Retractor.....36
 - How to wear your seat belt.....33
 - How your child should wear the seat belt.....35
 - Pregnant women, proper seat belt use.....34
 - Reminder light and buzzer.....448, 449
 - Seat belt pretensioners.....36
 - SRS warning light.....446
 - Seat belts shoulder anchor height
 - Adjustment.....36
 - Seat heaters.....365, 366
 - Seat position memory.....187
 - Seats
 - Adjustment precautions.....184
 - Adjustment.....184
 - Child seats/child restraint system installation.....49
 - Cleaning.....393
 - Driving position memory.....187
 - Folding down the rear seatbacks.....185
 - Head restraint.....190
 - Power easy access system.....187
 - Properly sitting in the seat.....33
 - Seat heaters.....366
 - Seat position memory.....187
 - Seat ventilators.....366
 - Seat ventilators.....366
 - Secondary Collision Brake.....340
 - Sensor
 - Automatic headlight system.....231
 - BSM (Blind Spot Monitor).....309
 - Front camera.....249
 - Humidity sensor.....362
 - Inside rear view mirror.....194
 - Intrusion sensor and tilt sensor.....99
 - Intrusion sensor.....99
 - Lexus parking assist-sensor.....313
 - LTA (Lane Tracing Assist).....268
 - Parking Support Brake function (rear-crossing vehicles).....333
 - Parking Support Brake function (static objects).....329
 - Radar sensor.....249
 - Rain-sensing windshield wipers.....243
 - RCTA (Rear Crossing Traffic Alert).....321
 - Tilt sensor.....99
 - S-FLOW mode.....363
 - Shift lever
 - If the shift lever cannot be shifted from P.....222
 - Multidrive.....221
 - Shift lever.....221
 - Shift lock system.....222
 - Side airbags.....38
 - Side doors.....134
 - Side mirrors.....195
 - Adjustment.....195
 - BSM (Blind Spot Monitor).....301
 - Folding and extending.....196

- Heaters 357
- Linked mirror function when reversing
..... 196
- Mirror position memory 196
- RCTA (Rear Crossing Traffic Alert) func-
tion 320
- Side turn signal lights**
- Replacing light bulbs 432
- Turn signal lever 224
- Smart entry & start system** 151
- Antenna location 151
- Entry functions 134, 140
- Starting the engine 217
- Warning message 452
- Snow tires**
- Snow tires 344
- Spare tire**
- Inflation pressure 496
- Storage location 468
- Spark plug** 495
- Specifications** 490
- Speedometer** 108, 111
- Sport mode** 337
- Steering lock**
- Column lock release 218
- Steering lock system warning message
..... 218
- Steering wheel** 192
- Adjustment 192
- Auto tilt away 192
- Heated steering wheel 365
- Meter control switches 117
- Power easy access system 187, 192
- Steering wheel position memory 187
- Stop lights**
- Emergency brake signal 340
- Replacing light bulbs 432
- Stop & Start system**
- Operation 294
- Replacing battery 484
- Stop & Start system 294
- System information display 118
- Warning light 446
- Stop & Start system information display** 118
- Storage feature** 372
- Storage precautions** 372
- Stuck**
- If the vehicle becomes stuck 487
- Suggestion function** 121
- Sunshade**
- Roof 200
- Sun visors** 380
- Switches**
- "ODO TRIP" switch 110, 114
- "SOS" button 64, 80
- Activating the Adaptive High-beam Sys-
tem 234
- Activating the Automatic High Beam
..... 237
- ASC switch 230
- Back door opener switch 140
- Brake hold switch 228
- BSM (Blind Spot Monitor) switch 309
- Cruise control switch 282, 292
- Door lock switches 136
- Driving mode select switch 337
- Driving position memory switches ... 187
- Emergency flashers switch 436
- Engine switch 217
- Fog light switch 239
- Heated steering wheel 366
- HUD (Head-up display) switch 124
- Ignition switch 217
- Instrument panel light control switches
..... 110, 114
- Intrusion sensor and tilt sensor cancel
switch 99
- Intrusion sensor cancel switch 99
- Lexus parking assist-sensor switch ... 314
- Light switches 231
- LTA (Lane Tracing Assist) switch 273
- Meter control switches 117

Moon roof switches..... 199
 Outside rear view mirror switches.... 195
 Paddle shift switches.....222, 223
 Parking brake switch 225
 PCS OFF switch..... 262
 PKSB (Parking Support Brake) switch
 325
 Power back door opener and closer
 switch..... 142
 Power back door switch..... 142
 Power window switch..... 197
 RCTA switch..... 320
 Rear window and outside rear view mir-
 ror defoggers switch 356
 Rear window wiper and washer switch
 245
 Seat heater switches 366
 Stop & Start cancel switch..... 299
 Tilt and telescopic steering control switch
 192
 Tire pressure warning reset switch .420
 Vehicle-to-vehicle distance switch .282
 Ventilators (seat ventilators)..... 366
 VSC OFF switch 340
 Window lock switch..... 199
 Windshield defogger switch..... 356
 Windshield wiper de-icer switch..... 360
 Windshield wipers and washer switch
 241

T

Tachometer 108, 111
 Rev indicator 113
 Rev peak 113
Tail lights 231
 Light switch..... 231
 Replacing light bulbs..... 432
Theft deterrent system
 Alarm 97
 Double locking system 96

Engine immobilizer system..... 84
 Intrusion sensor and tilt sensor 99
 Intrusion sensor..... 99
 Tilt sensor 99
Tilt sensor 99
Tire
 Chains..... 346
 Snow tires 344
Tire inflation pressure
 Maintenance data..... 496
 Tire inflation pressure display function411
 Warning light 445
Tire pressure warning system 411
 Function 411
 Initializing..... 420
 Installing tire pressure warning valves
 and transmitters..... 419
 Registering ID codes 422
 Warning light 445
Tires 409
 Checking..... 409
 Emergency tire puncture repair kit. 455
 If you have a flat tire 455, 467, 476
 Inflation pressure..... 424, 496
 Preparing and checking before winter
 344
 Replacing 455
 Rotating tires..... 410
 Run-flat tires..... 411, 476
 Size..... 496
 Spare tire..... 467, 496
 Tire inflation pressure display function411
 Tire pressure warning system 411
 Warning light 445
Tools 375, 457, 468
Top strap..... 62
Top tether anchorages 62
Towing
 Emergency towing..... 439
 Towing eyelet..... 441
 Trailer towing..... 211

Traction Control (TRC)..... 340
 Traction control 340
 Trailer towing.....211
 Transmission
 If the shift lever cannot be shifted from P
 222
 M position..... 223
 Multidrive..... 220
 Paddle shift switches..... 222, 223
 Selecting a driving mode..... 337
 TRC (Traction Control)..... 340
 Trip meters..... 109, 114
 Turn signal lights
 Replacing light bulbs..... 432
 Turn signal lever..... 224
 Wattage..... 498

U

USB charging ports 382

V

Vanity lights
 Vanity lights 380
 Wattage..... 498
 Vanity mirrors..... 380
 Vanity lights 380
 Vehicle data recording..... 7
 Vehicle identification number 491
 Vehicle Stability Control (VSC)..... 339
 Vehicle Stability Control+ (VSC+) 339
 Ventilators (seat ventilators) 365
 VSC (Vehicle Stability Control)..... 339
 VSC+ (Vehicle Stability Control +).... 339

W

Warning buzzers
 ABS.....446
 Airbags.....446
 Approach warning.....287

Brake hold 447
 Brake Override System 449
 Brake system.....444, 446
 Charging system..... 444
 Drive-Start Control..... 449
 Electric power steering..... 446
 Engine..... 445
 High coolant temperature..... 445
 Lexus parking assist-sensor 319, 447
 Low engine oil pressure..... 444
 LTA (Lane Tracing Assist)..... 268, 449
 Open door..... 135, 137
 Open window 198
 PKSA (Parking Support Alert).....312
 PKSB (Parking Support Brake)..... 448
 RCTA (Rear Crossing Traffic Alert)312,
 448
 Seat belt 448, 449
Warning lights 444
 ABS.....446
 Brake hold operated indicator..... 447
 Brake Override System 449
 Brake system.....444, 446
 Charging system..... 444
 Drive-Start Control..... 449
 Electric power steering..... 446
 High coolant temperature..... 445
 Lexus parking assist-sensor OFF indica-
 tor..... 447
 Low engine oil pressure..... 444
 Low fuel level 448
 LTA indicator 449
 Malfunction indicator lamp 445
 Parking brake indicator 447
 PKSB OFF indicator 448
 Pre-collision system..... 450
 RCTA OFF indicator..... 448
 Seat belt reminder lights..... 448, 449
 Slip indicator..... 447
 SRS..... 446
 Stop & Start cancel indicator 446

Tire pressure445

Warning messages.....452

Washer.....344

 Checking 408

 Headlight cleaners.....241

 Low washer fluid warning message 408

 Switch241, 245

Washing and waxing390

Weights490

Wheels.....425

 Replacing wheels.....425, 467

 Size.....496

Window glasses

 Front side windows.....393

 Power windows.....197

Window lock switch.....199

Windows

 Power windows.....197

 Rear window defogger.....357

 Washer241, 245

Windshield wiper de-icer.....361

Windshield wipers241

 Intermittent windshield wipers241

 Position243

 Rain-sensing windshield wipers.....241

Windshield wipers and washer241

Winter driving tips344

Wireless charger.....382

Wireless remote control.....132

 Battery-saving function.....152

 Locking/Unlocking132

 Replacing the battery.....428

For information regarding the equipment listed below, refer to the "NAVIGATION AND MULTI-MEDIA SYSTEM OWNER'S MANUAL".

- Audio/video system
- Navigation system
- Lexus parking assist monitor
- Panoramic view monitor

Toyota Motor Europe NV/SA, Avenue du Bourget 60 - 1140 Brussels, Belgium

www.toyota-europe.com



GAS STATION INFORMATION

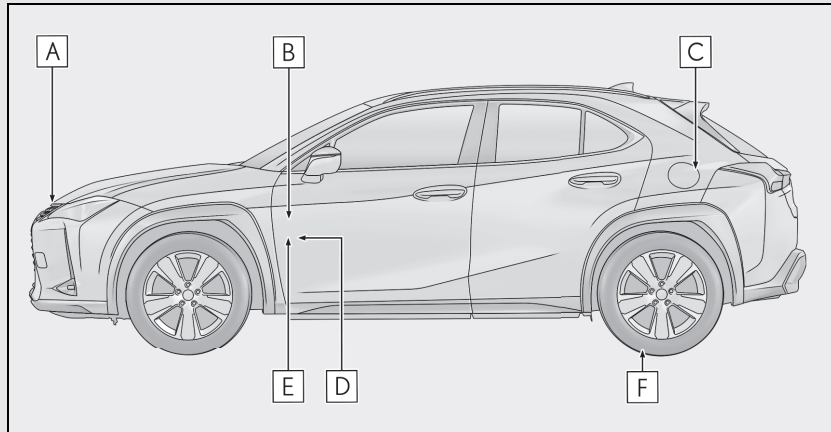

- A** Auxiliary catch lever (→P.400)
- B** Power back door switch* (→P.142)
- C** Fuel filler door (→P.248)
- D** Hood lock release lever (→P.400)
- E** Fuel filler door opener switch (→P.248)
- F** Tire inflation pressure (→P.496)

*: If equipped

Fuel tank capacity (Reference)	47 L (12.4 gal., 10.3 Imp.gal.)	
Fuel type	EU area: Unleaded gasoline conforming to European standard EN228 only	P.492
	Except EU area: Unleaded gasoline only	
Cold tire inflation pressure		P.496
Engine oil capacity (Drain and refill - reference)		P.493
Engine oil type		P.493