

Yaris Owner's Manual

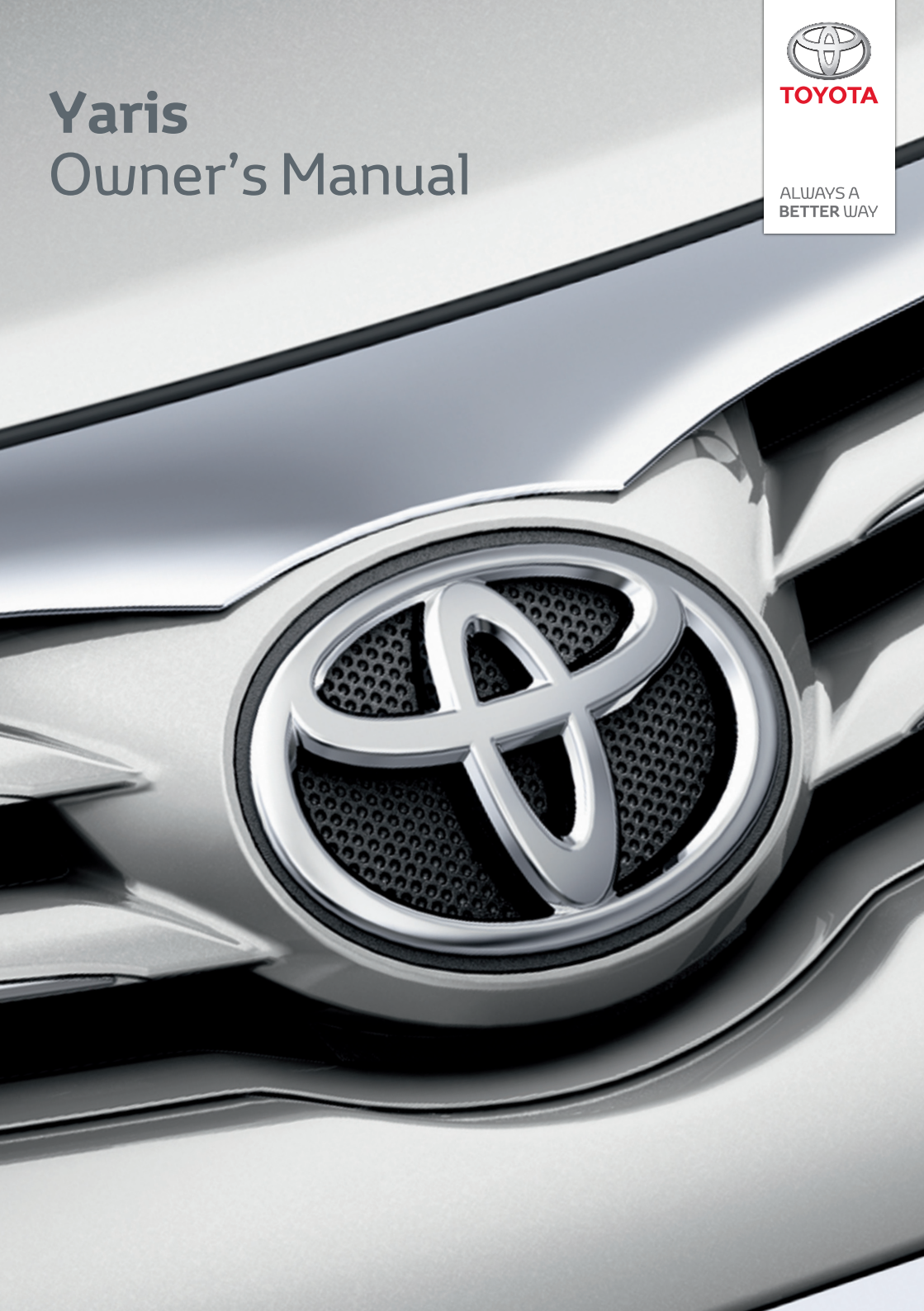

TOYOTA

ALWAYS A
BETTER WAY



Toyota Motor Europe NV/SA Address: Avenue du bourget
60 -1140 Brussels, Belgium

2015 TOYOTA MOTOR CORPORATION All rights
reserved. This material may not be reproduced or copied, in
whole or in part, without the written permission of Toyota
Motor Corporation

Pictorial index	Search by illustration	
For safety and security	Make sure to read through them (Main topics: Child seat, theft deterrent system)	1
Vehicle status information and indicators	Reading driving-related information (Main topics: Meters, multi-information display)	2
Before driving	Opening and closing the doors and windows, adjustment before driving (Main topics: Keys, doors, seats, power windows)	3
Driving	Operations and advice which are necessary for driving (Main topics: Starting hybrid system, refueling)	4
Interior features	Usage of the interior features (Main topics: Air conditioner, storage features)	5
Maintenance and care	Caring for your vehicle and maintenance procedures (Main topics: Interior and exterior, light bulbs)	6
When trouble arises	What to do in case of malfunction and emergency (Main topics: 12-volt battery discharge, flat tire)	7
Vehicle specifications	Vehicle specifications, customizable features (Main topics: Fuel, oil, tire inflation pressure)	8
Index	Search by symptom	
	Search alphabetically	

2 TABLE OF CONTENTS

For your information	6
Reading this manual.....	9
How to search	10
Pictorial index.....	12

1 For safety and security

1-1. For safe use	
Before driving.....	30
For safe driving	31
Seat belts	33
SRS airbags.....	36
Exhaust gas precautions	44
1-2. Child safety	
Airbag manual on-off system	45
Riding with children.....	46
Child restraint systems	47
1-3. Emergency assistance	
eCall.....	66
1-4. Hybrid system	
Hybrid system features	76
Hybrid system precautions ...	79
1-5. Theft deterrent system	
Immobilizer system	84
Double locking system.....	85
Alarm	86

2 Vehicle status information and indicators

2-1. Instrument cluster

Warning lights and indicators	90
Gauges and meters (vertical display).....	94
Gauges and meters (horizontal display)	99
Multi-information display (vertical display).....	103
Multi-information display (horizontal display).....	109
Head-up display.....	116
Energy monitor/consumption screen.....	120

3 Before driving

3-1. Key information

Keys.....	128
-----------	-----

3-2. Opening, closing and locking the doors

Side doors.....	133
Back door.....	137
Smart entry & start system .	140

3-3. Adjusting the seats

Front seats.....	145
Rear seats	146
Head restraints	147

3-4. Adjusting the steering wheel and mirrors

Steering wheel.....	151
Inside rear view mirror	152
Outside rear view mirrors....	153

3-5. Opening and closing the windows

Power windows **156**

4 Driving

4-1. Before driving

Driving the vehicle **160**

Cargo and luggage **166**

Trailer towing (vehicles without towing packages - including Reunion) **167**

Trailer towing (vehicles with towing packages - except for Reunion) **167**

4-2. Driving procedures

Power (ignition) switch (vehicles without a smart entry & start system) **173**

Power (ignition) switch (vehicles with a smart entry & start system) **175**

EV drive mode **179**

Hybrid transmission **181**

Turn signal lever **184**

Parking brake **184**

Brake Hold **187**

4-3. Operating the lights and wipers

Headlight switch **190**

AHB (Automatic High Beam) **193**

Fog light switch **196**

Windshield wipers and washer **197**

Rear window wiper and washer **200**

4-4. Refueling

Opening the fuel tank cap... **202**

4-5. Using the driving support systems

Toyota Safety Sense **204**

PCS (Pre-Collision System) **209**

LTA (Lane Tracing Assist) ... **220**

Dynamic radar cruise control with full-speed range **230**

Speed limiter **242**

RSA (Road Sign Assist) **244**

BSM (Blind Spot Monitor) ... **248**

Toyota parking assist-sensor **253**

RCTA (Rear Crossing Traffic Alert) **260**

PKSB (Parking Support Brake) **265**

Parking Support Brake function (static objects) **270**

Parking Support Brake function (rear-crossing vehicles) ... **273**

Driving mode select switch **275**

GPF (Gasoline Particulate Filter) system **276**

Driving assist systems **277**

4-6. Driving tips

Hybrid vehicle driving tips ... **282**

Winter driving tips **284**



4 TABLE OF CONTENTS

5 Interior features

5-1. Using the air conditioning system and defogger

Automatic air conditioning system288

Heated steering wheel/seat heaters293

5-2. Using the interior lights

Interior lights list295

5-3. Using the storage features

List of storage features297

Luggage compartment features299

5-4. Other interior features

Other interior features303

6 Maintenance and care

6-1. Maintenance and care

Cleaning and protecting the vehicle exterior312

Cleaning and protecting the vehicle interior315

6-2. Maintenance

Maintenance requirements .318

6-3. Do-it-yourself maintenance

Do-it-yourself service precautions320

Hood322

Positioning a floor jack323

Engine compartment325

12-volt battery330

Tires332

Tire inflation pressure342

Wheels344

Air conditioning filter346

Cleaning the hybrid battery (traction battery) air intake vent and filter348

Wireless remote control/electronic key battery351

Checking and replacing fuses354

Light bulbs357

7 When trouble arises

7-1. Essential information

Emergency flashers366

If your vehicle has to be stopped in an emergency366

If the vehicle is submerged or water on the road is rising 367

7-2. Steps to take in an emergency

- If your vehicle needs to be towed**369**
- If you think something is wrong**372**
- If a warning light turns on or a warning buzzer sounds.....**374**
- If a warning message is displayed**383**
- If you have a flat tire (vehicles with an emergency tire puncture repair kit)**386**
- If you have a flat tire (vehicles with a spare tire).....**397**
- If the hybrid system will not start**405**
- If you lose your keys**407**
- If the electronic key does not operate properly (vehicles with a smart entry & start system)**407**
- If the 12-volt battery is discharged.....**409**
- If your vehicle overheats.....**414**
- If the vehicle becomes stuck**417**

8 Vehicle specifications

8-1. Specifications

- Maintenance data (fuel, oil level, etc.).....**420**
- Fuel information**430**

8-2. Customization

- Customizable features**431**

8-3. Initialization

- Items to initialize**440**

8-4. Certifications

- Certifications**441**

Index

- What to do if... (Troubleshooting)**562**
- Alphabetical Index**565**

1

2

3

4

5

6

7

8

For your information

Main Owner's Manual

Please note that this manual applies to all models and explains all equipment, including options. Therefore, you may find some explanations for equipment not installed on your vehicle.

All specifications provided in this manual are current at the time of printing. However, because of the Toyota policy of continual product improvement, we reserve the right to make changes at any time without notice.

Depending on specifications, the vehicle shown in the illustrations may differ from your vehicle in terms of equipment.

Accessories, spare parts and modification of your Toyota

Both genuine Toyota and a wide variety of other spare parts and accessories for Toyota vehicles are currently available on the market. Should it be determined that any of the genuine Toyota parts or accessories supplied with the vehicle need to be replaced, Toyota recommends that genuine Toyota parts or accessories, be used to replace them. Other parts or accessories of matching quality can also be used. Toyota cannot accept any liability or

guarantee spare parts and accessories which are not genuine Toyota products, nor for replacement or installation involving such parts. In addition, damage or performance problems resulting from the use of non-genuine Toyota spare parts or accessories may not be covered under warranty.

Also, remodeling like this will have an effect on advanced safety equipment such as Toyota Safety Sense and there is a danger that it will not work properly or the danger that it may work in situations where it should not be working.

Installation of an RF-transmitter system

The installation of an RF-transmitter system in your vehicle could affect electronic systems such as:

- Hybrid system
- Multiport fuel injection system/sequential multiport fuel injection system
- Toyota Safety Sense (if equipped)
- Dynamic radar cruise control with full-speed range (if equipped)
- Anti-lock brake system
- SRS airbag system
- Seat belt pretensioner system

Be sure to check with any authorized Toyota retailer or Toyota

authorized repairer, or any reliable repairer for precautionary measures or special instructions regarding installation of an RF-transmitter system.

Further information regarding frequency bands, power levels, antenna positions and installation provisions for the installation of RF-transmitters, is available on request at any authorized Toyota retailer or Toyota authorized repairer, or any reliable repairer.

High voltage parts and cables on the hybrid vehicles emit approximately the same amount of electromagnetic waves as the conventional gasoline powered vehicles or home electronic appliances despite of their electromagnetic shielding.

Unwanted noise may occur in the reception of the radio frequency transmitter (RF-transmitter).

Vehicle data recording

The vehicle is equipped with sophisticated computers that will record certain data, such as:

- Engine speed/Electric motor speed (traction motor speed)
- Accelerator status
- Brake status
- Vehicle speed
- Operation status of the driving assist systems
- Images from the cameras

Your vehicle is equipped with cameras. Contact any authorized Toyota retailer or Toyota authorized repairer, or any reliable repairer for the location of recording cameras.

The recorded data varies according to the vehicle grade level, options and destinations with which it is equipped.

These computers do not record conversations or sounds, and only record images outside of the vehicle in certain situations.

● Data usage

Toyota may use the data recorded in this computer to diagnose malfunctions, conduct research and development, and improve quality.

Toyota will not disclose the recorded data to a third party except:

- With the consent of the vehicle owner or with the consent of the lessee if the vehicle is leased
- In response to an official request by the police, a court of law or a government agency
- For use by Toyota in a lawsuit
- For research purposes where the data is not tied to a specific vehicle or vehicle owner
- Recorded image information can be erased by any authorized Toyota retailer or Toyota authorized repairer, or any reliable repairer.

The image recording function can be disabled. However, if the function is disabled, data from when the system operates will not be available.

Scrapping of your Toyota

The SRS airbag and seat belt pretensioner devices in your Toyota contain explosive chemicals. If the vehicle is scrapped with the airbags and seat belt pretensioners left as they are, this may cause an accident such as fire. Be sure to have the systems of the SRS airbag and seat belt pretensioner removed and disposed of by a qualified service shop or by any authorized Toyota retailer or Toyota authorized repairer, or any reliable repairer before you scrap your vehicle.



WARNING

■ General precautions while driving

Driving under the influence: Never drive your vehicle when under the influence of alcohol or drugs that have impaired your ability to operate your vehicle. Alcohol and certain drugs delay reaction time, impair judgment and reduce coordination, which could lead to an accident that could result in death or serious injury.

Defensive driving: Always drive defensively. Anticipate mistakes that other drivers or pedestrians might make and be ready to avoid accidents.

Driver distraction: Always give your full attention to driving. Anything that distracts the driver, such as adjusting controls, talking on a cellular phone or reading can result in a collision with resulting death or serious injury to you, your occupants or others.

■ General precaution regarding children's safety

Never leave children unattended in the vehicle, and never allow children to have or use the key.

Children may be able to start the vehicle or shift the vehicle into neutral.



There is also a danger that children may injure themselves by playing with the windows, or other features of the vehicle. In addition, heat build-up or extremely cold temperatures inside the vehicle can be fatal to children.

Toyota Motor Europe NV/SA, Avenue du Bourget 60 - 1140 Brussels, Belgium www.toyota-europe.com

Reading this manual



Explains symbols used in this manual.

Symbols in this manual

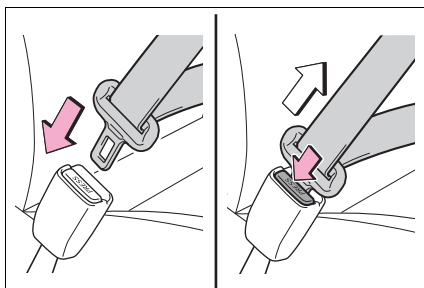

Symbols	Meanings
	WARNING: Explains something that, if not obeyed, could cause death or serious injury to people.
	NOTICE: Explains something that, if not obeyed, could cause damage to or a malfunction in the vehicle or its equipment.
1 2 3...	Indicates operating or working procedures. Follow the steps in numerical order.

Symbols in illustrations

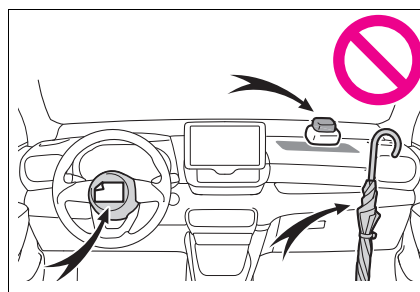

Symbols	Meanings
	Indicates the action (pushing, turning, etc.) used to operate switches and other devices.
	Indicates the outcome of an operation (e.g. a lid opens).



Symbols	Meanings
	Indicates the component or position being explained.
	Means Do not, Do not do this, or Do not let this happen.

How to search**■ Searching by name**

- Alphabetical index: →P.565

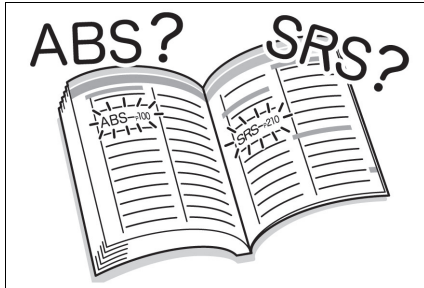
**■ Searching by installation position**

- Pictorial index: →P.12

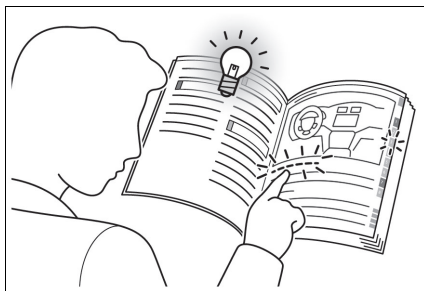
**■ Searching by symptom or sound**

- What to do if... (Troubleshooting): →P.562

**■ Searching by title**

- Table of contents: →P.2

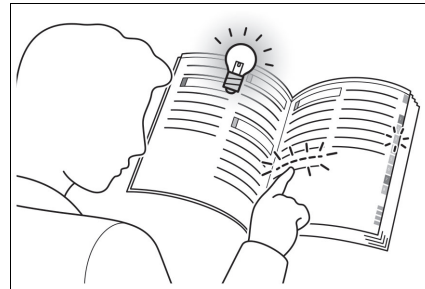

Pictorial index

■ Exterior

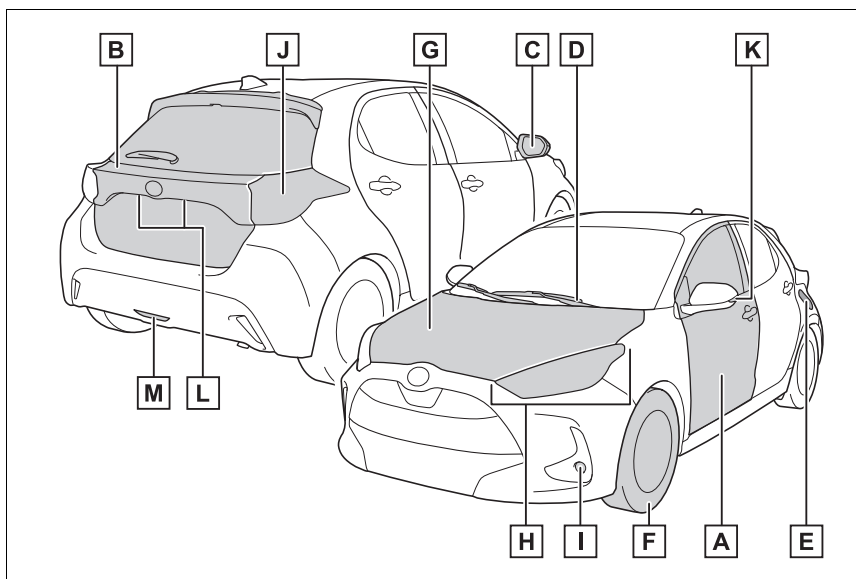

A	Side doors	P.133
	Locking/unlocking	P.133
	Opening/closing the side windows	P.156
	Locking/unlocking by using the mechanical key *1	P.408
B	Back door	P.137
	Locking/unlocking	P.139
C	Outside rear view mirrors	P.153
	Adjusting the mirror angle	P.153
	Folding the mirrors	P.154
	Defogging the mirrors	P.290
D	Windshield wipers	P.197
	Precautions for winter season	P.284
	Precautions for car wash	P.313
E	Fuel filler door	P.202

Refueling method	P.203
Fuel type/fuel tank capacity	P.422
F Tires	P.332
Tire size/inflation pressure	P.427
Winter tires/tire chains	P.284
Checking/rotation/tire pressure warning system	P.332
Coping with flat tires.....	P.386, 397
G Hood.....	P.322
Opening	P.322
Engine oil	P.423
Coping with overheating	P.414

Light bulbs of the exterior lights for driving

(Replacing method: P.357, Watts: P.428)

H Headlights/front position lights/daytime running lights/turn signal lights	P.184, 190
I Front fog lights *2	P.196
J Tail lights/turn signal lights	P.184, 190
Stop lights	
K Side turn signal lights	P.184
L License plate light.....	P.190
M Rear fog light.....	P.196
Back-up light	
Shifting the shift position to R	P.181

*1: Vehicles with a smart entry & start system

*2: If equipped

■ Instrument panel (left-hand drive vehicles)

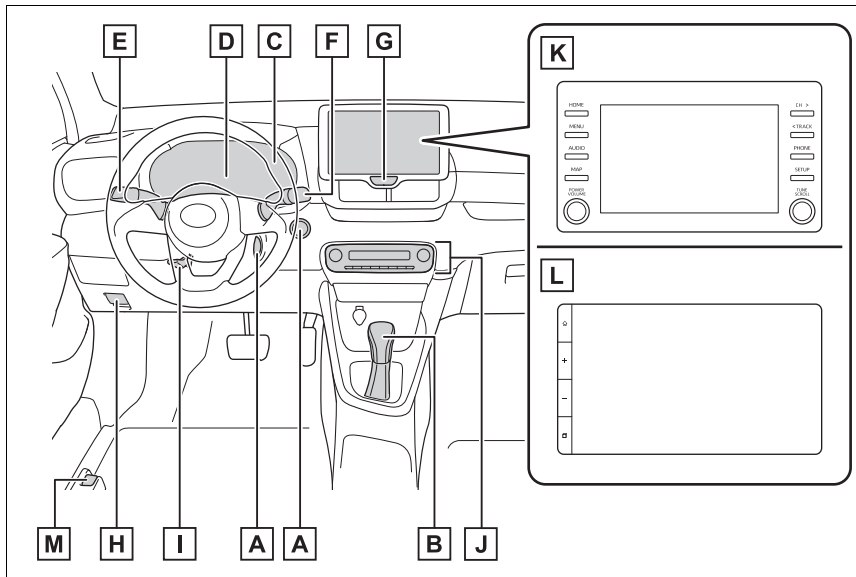

- A Power switch**P.173, 175
 - Starting the hybrid system/changing the positions*¹P.173
 - Starting the hybrid system/changing the modes*²P.175
 - Emergency stop of the hybrid systemP.366
 - When the hybrid system will not startP.405
 - Warning messagesP.383
- B Shift lever**P.181
 - Changing the shift positionP.181
 - Precautions for towingP.369
 - When the shift lever does not moveP.182
- C Meters**P.94, 99
 - Reading the meters/adjusting the instrument panel lightP.94, 99
 - Warning lights/indicator lightsP.90
 - When a warning light turns onP.374

D	Multi-information display	P.103, 109
	Display	P.103, 109
	Energy monitor.....	P.120
	When a warning message is displayed.....	P.383
E	Turn signal lever	P.184
	Headlight switch	P.190
	Headlights/front position lights/tail lights/daytime running lights	P.190
	Front fog lights ^{*3} /rear fog light	P.196
F	Windshield wiper and washer switch	P.197
	Rear window wiper and washer switch ^{*3}	P.200
	Usage.....	P.197, 200
	Adding washer fluid.....	P.329
G	Emergency flasher switch	P.366
H	Hood lock release lever	P.322
I	Tilt and telescopic steering lock release lever	P.151
J	Air conditioning system	P.288
	Usage.....	P.288
	Rear window defogger	P.290
K	Multimedia system (7-inch/8-inch display model) ^{*3, 4}	
L	Multimedia system (9-inch display model) ^{*3, 5}	
M	Fuel filler door opener	P.203

*1: Vehicles without a smart entry & start system

*2: Vehicles with a smart entry & start system

*3: If equipped

*4: Refer to "Navigation and multimedia system Owner's manual".

*5: Refer to "TOYOTA SMART CONNECT Owner's manual".

■ Switches (left-hand drive vehicles)

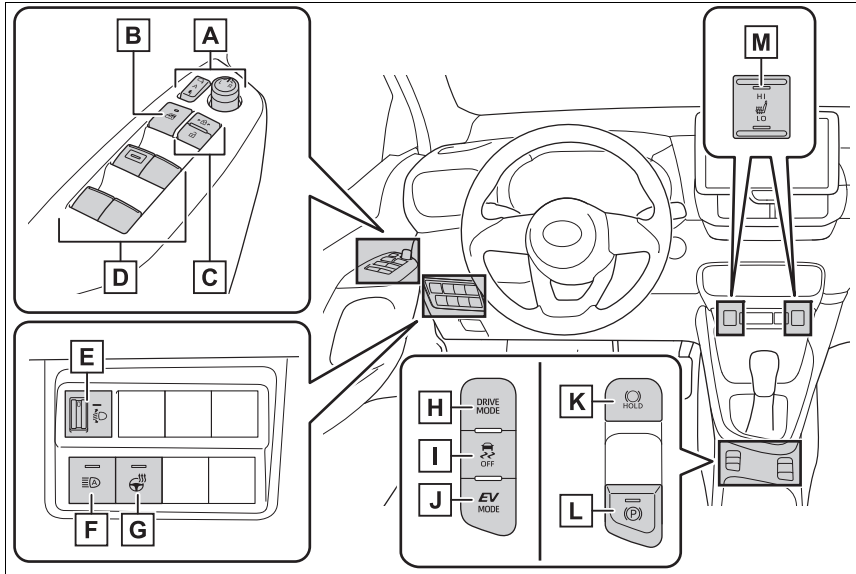

A	Outside rear view mirror switches	P.153
B	Window lock switch	P.158
C	Door lock switches	P.136
D	Power window switches	P.156
E	Headlight leveling dial	P.192
F	Automatic High Beam switch *	P.193
G	Heated steering wheel switch *	P.294
H	Driving mode select switch.....	P.275
I	VSC OFF switch	P.278
J	EV drive mode switch.....	P.179
K	Brake hold switch	P.187
L	Parking brake switch	P.184

Precautions for winter season.....P.285

M **Seat heater switches** *P.294

*: If equipped

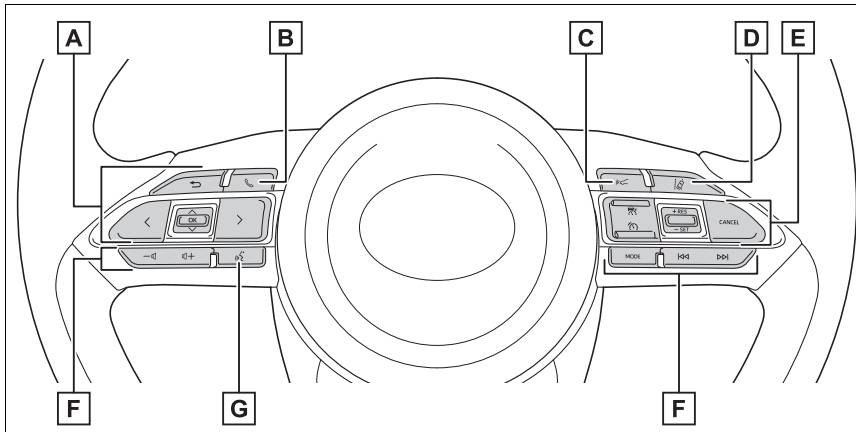

A **Meter control switches** P.104, 110

B **Phone switch** *²

C **Vehicle-to-vehicle distance switch** *¹P.235

D **LTA (Lane Tracing Assist) switch** *¹P.220

E **Cruise control switches** *¹

Dynamic radar cruise control with full-speed range *¹P.230

Speed limiter main switch *¹P.242

F **Audio remote control switches** *²

G **Talk switch** *²

*¹: If equipped

*²: Refer to “Navigation and multimedia system Owner’s manual”.

■ Interior (left-hand drive vehicles)

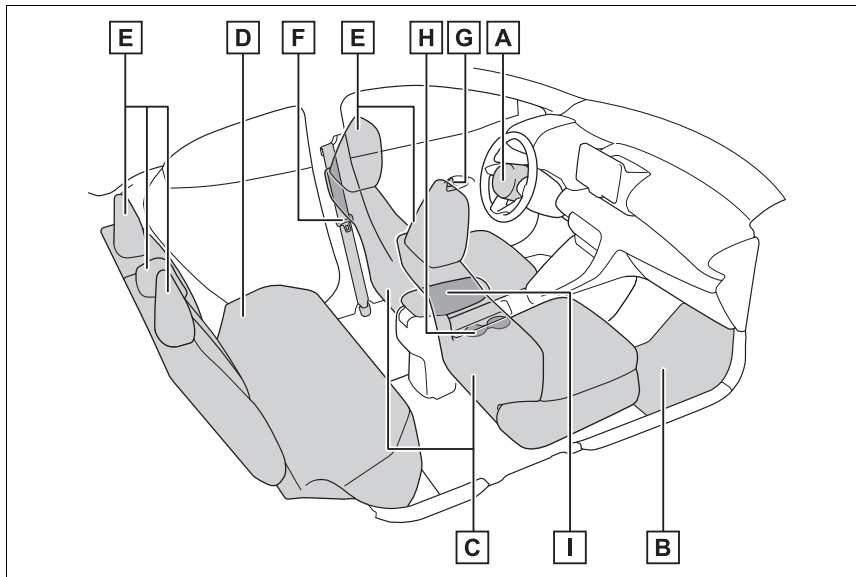

A	SRS airbags	P.36
B	Floor mats	P.30
C	Front seats	P.145
D	Rear seats	P.146
E	Head restraints	P.147
F	Seat belts	P.33
G	Inside lock buttons	P.136
H	Cup holders	P.298
I	Console box	P.299

■ Ceiling (left-hand drive vehicles)

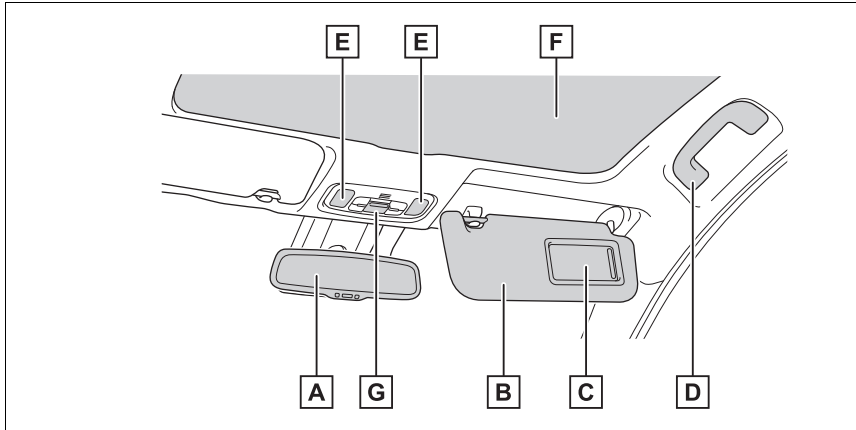

- A** Inside rear view mirrorP.152
- B** Sun visors^{*1}P.307
- C** Vanity mirrors^{*2}P.307
- D** Assist gripsP.308
- E** Interior lights/personal lightsP.295
- F** Panoramic roof shade^{*2}.....P.309
- G** "SOS" button^{*2}P.66

^{*1}: NEVER use a rearward facing child restraint on a seat protected by an ACTIVE AIRBAG in front of it, DEATH or SERIOUS INJURY to the CHILD can occur. (→P.49)



*2: If equipped

■ Instrument panel (right-hand drive vehicles)

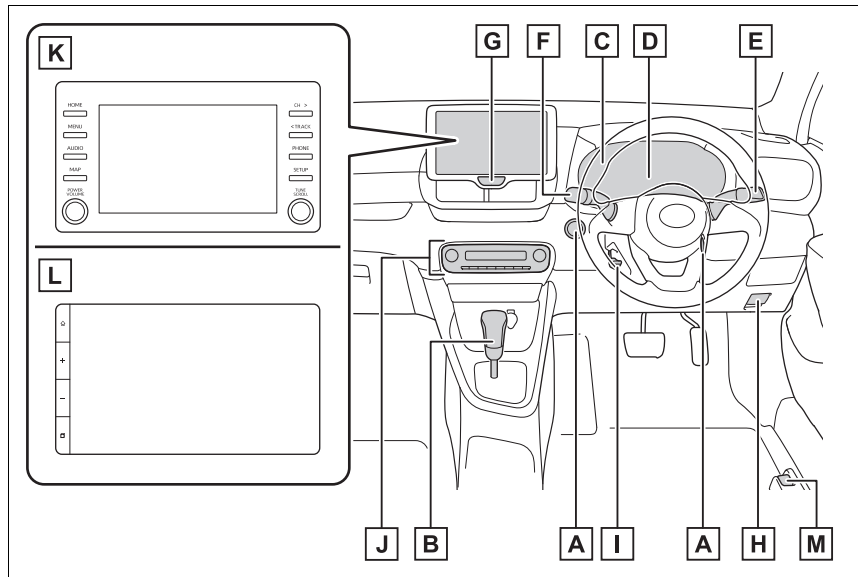

A Power switchP.173, 175

Starting the hybrid system/changing the positions*¹P.173

Starting the hybrid system/changing the modes*²P.175

Emergency stop of the hybrid systemP.366

When the hybrid system will not startP.405

Warning messagesP.383

B Shift leverP.181

Changing the shift positionP.181

Precautions for towingP.369

When the shift lever does not moveP.182

C MetersP.94, 99

Reading the meters/adjusting the instrument panel lightP.94, 99

Warning lights/indicator lightsP.90

When a warning light turns onP.90

D	Multi-information display	P.103, 109
	Display	P.103, 109
	Energy monitor.....	P.120
	When a warning message is displayed.....	P.383
E	Windshield wiper and washer switch	P.197
	Rear window wiper and washer switch ^{*3}	P.200
	Usage.....	P.197, 200
	Adding washer fluid.....	P.329
F	Turn signal lever	P.184
	Headlight switch	P.190
	Headlights/front position lights/tail lights/daytime running lights	P.190
	Front fog lights ^{*3} /rear fog light	P.196
G	Emergency flasher switch	P.366
H	Hood lock release lever	P.322
I	Tilt and telescopic steering lock release lever	P.151
J	Air conditioning system	P.288
	Usage.....	P.288
	Rear window defogger	P.290
K	Multimedia system (7-inch/8-inch display model) ^{*3, 4}	
L	Multimedia system (9-inch display model) ^{*3, 5}	
M	Fuel filler door opener	P.203

*1: Vehicles without a smart entry & start system

*2: Vehicles with a smart entry & start system

*3: If equipped

*4: Refer to "Navigation and multimedia system Owner's manual".

*5: Refer to "TOYOTA SMART CONNECT Owner's manual".

■ Switches (right-hand drive vehicles)

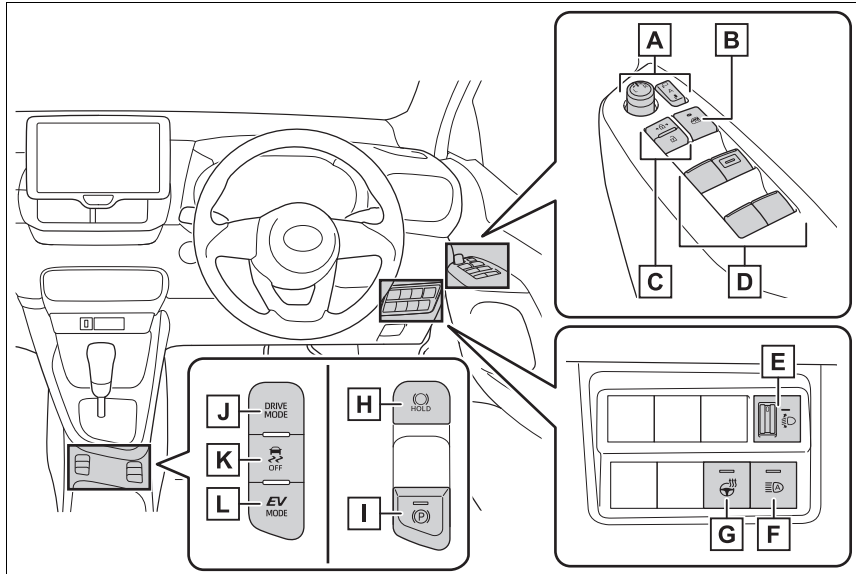

A	Outside rear view mirror switches	P.153
B	Window lock switch	P.158
C	Door lock switches	P.136
D	Power window switches	P.156
E	Headlight leveling dial	P.192
F	Automatic High Beam switch	P.193
G	Heated steering wheel switch*	P.294
H	Brake hold switch	P.187
I	Parking brake switch	P.184
	Precautions for winter season.....	P.285
J	Driving mode select switch.....	P.275
K	VSC OFF switch	P.278

L EV drive mode switch.....P.179

*: If equipped

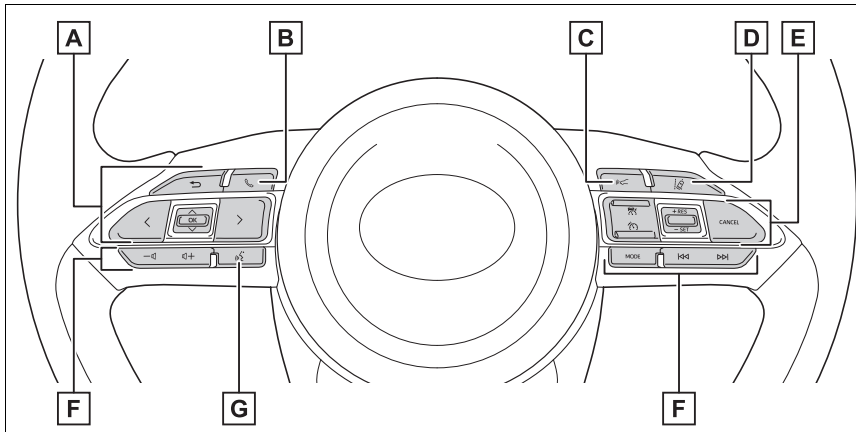

A Meter control switches P.104, 110

B Phone switch*

C Vehicle-to-vehicle distance switch.....P.235

D LTA (Lane Tracing Assist) switchP.220

E Cruise control switches

Dynamic radar cruise control with full-speed rangeP.230

Speed limiter main switch.....P.242

F Audio remote control switches*

G Talk switch*

*: Refer to "Navigation and multimedia system Owner's manual".

■ Interior (right-hand drive vehicles)

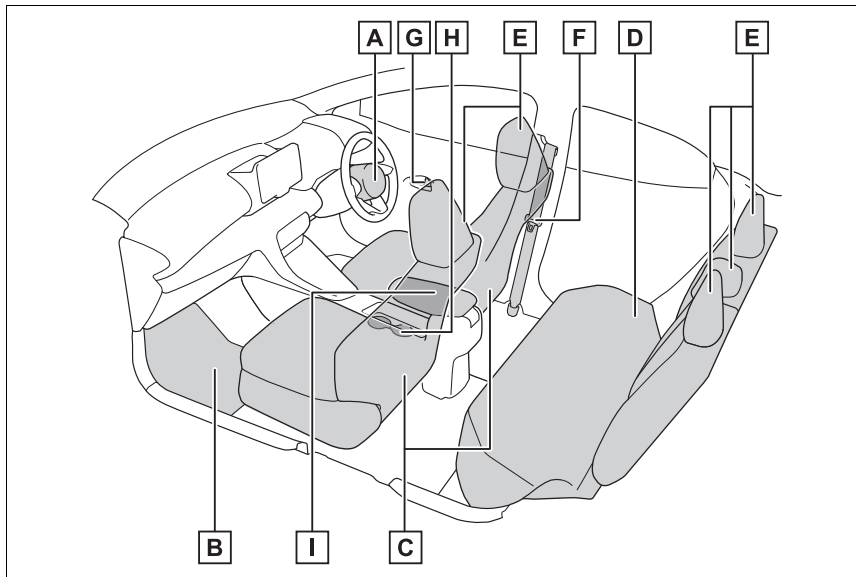

A	SRS airbags	P.36
B	Floor mats	P.30
C	Front seats	P.145
D	Rear seats	P.146
E	Head restraints	P.147
F	Seat belts	P.33
G	Inside lock buttons	P.136
H	Cup holders	P.298
I	Console box	P.299

■ Ceiling (right-hand drive vehicles)

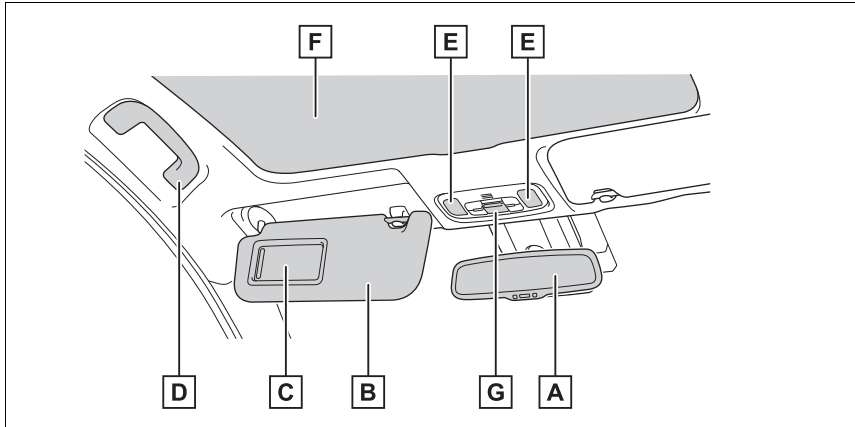

A	Inside rear view mirror	P.152
B	Sun visors ^{*1}	P.307
C	Vanity mirrors ^{*2}	P.307
D	Assist grips	P.308
E	Interior lights/personal lights	P.295
F	Panoramic roof shade ^{*2}	P.309
G	“SOS” button.....	P.66

^{*1}: NEVER use a rearward facing child restraint on a seat protected by an ACTIVE AIRBAG in front of it, DEATH or SERIOUS INJURY to the CHILD can occur.
(→P.49)



*2: If equipped

For safety and security

1

1-1. For safe use	
Before driving	30
For safe driving	31
Seat belts	33
SRS airbags	36
Exhaust gas precautions	44
1-2. Child safety	
Airbag manual on-off system	45
Riding with children	46
Child restraint systems	47
1-3. Emergency assistance	
eCall	66
1-4. Hybrid system	
Hybrid system features	76
Hybrid system precautions .	79
1-5. Theft deterrent system	
Immobilizer system	84
Double locking system.....	85
Alarm	86

1

For safety and security

Before driving

Observe the following before starting off in the vehicle to ensure safety of driving.

Floor mat

Use only floor mats designed specifically for vehicles of the same model and model year as your vehicle. Fix them securely in place onto the carpet.

- 1 Insert the retaining hooks (clips) into the floor mat eyelets.

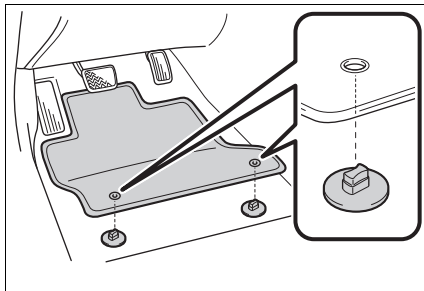

- 2 Turn the upper knob of each retaining hook (clip) to secure the floor mats in place.

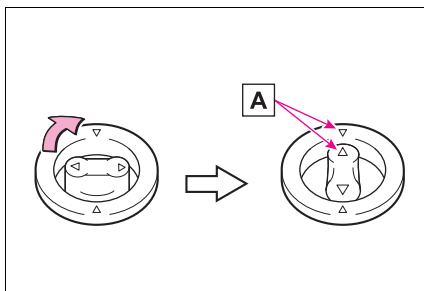

Always align the \triangle marks **A**.

The shape of the retaining hooks (clips)

may differ from that shown in the illustration.

WARNING

Observe the following precautions. Failure to do so may cause the driver's floor mat to slip, possibly interfering with the pedals while driving. An unexpectedly high speed may result or it may become difficult to stop the vehicle. This could lead to an accident, resulting in death or serious injury.

When installing the driver's floor mat

- Do not use floor mats designed for other models or different model year vehicles, even if they are Toyota Genuine floor mats.
- Only use floor mats designed for the driver's seat.
- Always install the floor mat securely using the retaining hooks (clips) provided.
- Do not use two or more floor mats on top of each other.
- Do not place the floor mat bottom-side up or upside-down.

Before driving

- Check that the floor mat is securely fixed in the correct place with all the provided retaining hooks (clips). Be especially careful to perform this check after cleaning the floor.

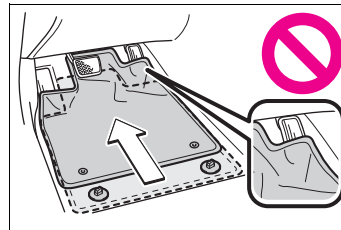

**WARNING**

- With the hybrid system stopped and the shift lever in P, fully depress each pedal to the floor to make sure it does not interfere with the floor mat.

For safe driving

For safe driving, adjust the seat and mirror to an appropriate position before driving.

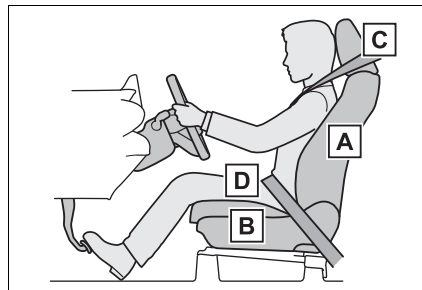
Correct driving posture

- A** Adjust the angle of the seatback so that you are sitting straight up and so that you do not have to lean forward to steer. (→P.145)
- B** Adjust the seat so that you can depress the pedals fully and so that your arms bend slightly at the elbow when gripping the steering wheel. (→P.145)
- C** Lock the head restraint in place with the center of the head restraint closest to the top of your ears. (→P.147)
- D** Wear the seat belt correctly. (→P.33)

**WARNING****■ For safe driving**

Observe the following precautions. Failure to do so may result in death or serious injury.

- Do not adjust the position of the driver's seat while driving. Doing so could cause the driver to lose control of the vehicle.
- Do not place a cushion between the driver or passenger and the seat-back. A cushion may prevent correct posture from being achieved, and reduce the effectiveness of the seat belt and head restraint.
- Do not place anything under the front seats. Objects placed under the front seats may become jammed in the seat tracks and stop the seat from locking in place. This may lead to an accident and the adjustment mechanism may also be damaged.
- Always observe the legal speed limit when driving on public roads.
- When driving over long distances, take regular breaks before you start to feel tired. Also, if you feel tired or sleepy while driving, do not force yourself to continue driving and take a break immediately.

Adjusting the mirrors

Make sure that you can see backward clearly by adjusting the inside and outside rear view mirrors properly. (→P.152, 153)

Correct use of the seat belts

Make sure that all occupants are wearing their seat belts before driving the vehicle. (→P.33)

Use a child restraint system appropriate for the child until the child becomes large enough to properly wear the vehicle's seat belt.

(→P.47)

Seat belts

Make sure that all occupants are wearing their seat belts before driving the vehicle.

WARNING

Observe the following precautions to reduce the risk of injury in the event of sudden braking, sudden swerving or an accident.

Failure to do so may cause death or serious injury.

■ Wearing a seat belt

- Ensure that all passengers wear a seat belt.
- Always wear a seat belt properly.
- Each seat belt should be used by one person only. Do not use a seat belt for more than one person at once, including children.
- Toyota recommends that children be seated in the rear seat and always use a seat belt and/or an appropriate child restraint system.
- To achieve a proper seating position, do not recline the seat more than necessary. The seat belt is most effective when the occupants are sitting up straight and well back in the seats.
- Do not wear the shoulder belt under your arm.
- Always wear your seat belt low and snug across your hips.

■ Pregnant women

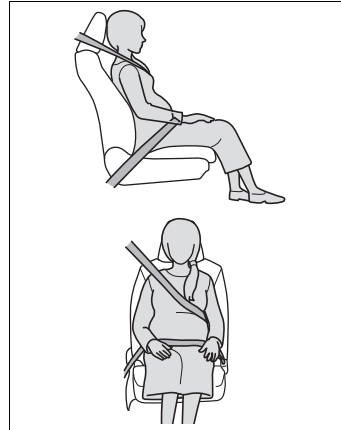

Obtain medical advice and wear the seat belt in the proper way. (→P.34)

Women who are pregnant should position the lap belt as low as possible over the hips in the same manner as other occupants, extending the shoulder belt completely over the shoulder and avoiding belt contact with the rounding of the abdominal area.

If the seat belt is not worn properly, not only the pregnant woman, but also the fetus could suffer death or serious injury as a result of sudden braking or a collision.

■ People suffering illness

Obtain medical advice and wear the seat belt in the proper way. (→P.34)

■ When children are in the vehicle

→P.63

■ Seat belt damage and wear

- Do not damage the seat belts by allowing the belt, plate, or buckle to be jammed in the door.

**WARNING**

- Inspect the seat belt system periodically. Check for cuts, fraying, and loose parts. Do not use a damaged seat belt until it is replaced. Damaged seat belts cannot protect an occupant from death or serious injury.
- Ensure that the belt and plate are locked and the belt is not twisted. If the seat belt does not function correctly, immediately contact any authorized Toyota retailer or Toyota authorized repairer, or any reliable repairer.
- Replace the seat assembly, including the belts, if your vehicle has been involved in a serious accident, even if there is no obvious damage.
- Do not attempt to install, remove, modify, disassemble or dispose of the seat belts. Have any necessary repairs carried out by any authorized Toyota retailer or Toyota authorized repairer, or any reliable repairer. Inappropriate handling may lead to incorrect operation.

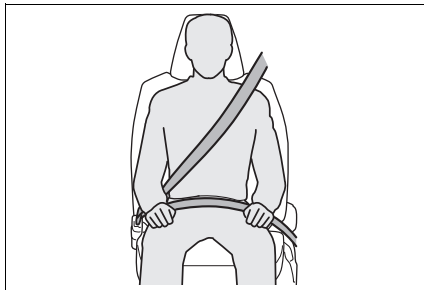
Correct use of the seat belts

- Extend the shoulder belt so that it comes fully over the shoulder, but does not come into contact with the neck or slide off the shoulder.

- Position the lap belt as low as possible over the hips.
- Adjust the position of the seat-back. Sit up straight and well back in the seat.
- Do not twist the seat belt.

Child seat belt usage

The seat belts of your vehicle were principally designed for persons of adult size.

- Use a child restraint system appropriate for the child, until the child becomes large enough to properly wear the vehicle's seat belt. (→P.47)
- When the child becomes large enough to properly wear the vehicle's seat belt, follow the instructions regarding seat belt usage. (→P.33)

Seat belt regulations

If seat belt regulations exist in the country where you reside, please contact any authorized Toyota retailer or Toyota authorized repairer, or any reliable repairer for seat belt replacement or installation.

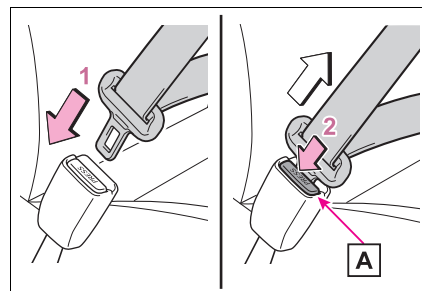
Fastening and releasing the seat belt

- 1 To fasten the seat belt, push the plate into the buckle until a click sound is heard.

- 2 To release the seat belt, press the release button **A**.

■ Emergency locking retractor (ELR)

The retractor will lock the belt during a sudden stop or on impact. It may also lock if you lean forward too quickly. When the seat belt locks, pull the belt strongly and then release the belt, then a slow and easy pulling will allow the belt to extend.

■ After using the rear center seat belt

Stow seat belt buckle in the pocket.

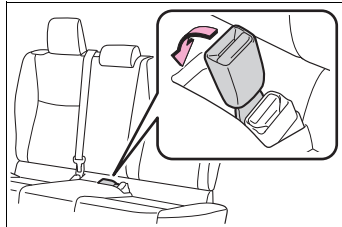

Seat belt pretensioners (front and outboard rear seats)

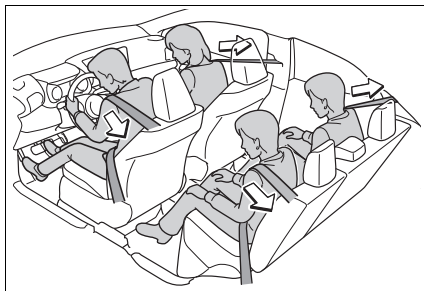

The pretensioners help the seat belts to quickly restrain the occupants by retracting the seat belts when the vehicle is subjected to certain types of severe frontal or side collision.

The pretensioners do not activate in the

event of a minor frontal impact, a minor side impact, a rear impact or a vehicle rollover.

■ Replacing the belt after the pretensioner has been activated

If the vehicle is involved in multiple collisions, the pretensioner will activate for the first collision, but will not activate for the second or subsequent collisions.

■ PCS-linked seat belt pretensioner control (vehicles with Toyota Safety Sense)

If the PCS (Pre-Collision System) determines that the possibility of a collision with a vehicle is high, the seat belt pretensioners will be prepared to operate.

⚠ WARNING

■ Seat belt pretensioners

If the pretensioner has activated, the SRS warning light will come on. In that case, the seat belt cannot be used again and must be replaced at any authorized Toyota retailer or Toyota authorized repairer, or any reliable repairer.

Failure to do so may cause death or serious injury.

SRS airbags

The SRS airbags inflate when the vehicle is subjected to certain types of severe impacts that may cause significant injury to the occupants. They work together with the seat belts to help reduce the risk of death or serious injury.

SRS airbag system

■ Location of the SRS airbags

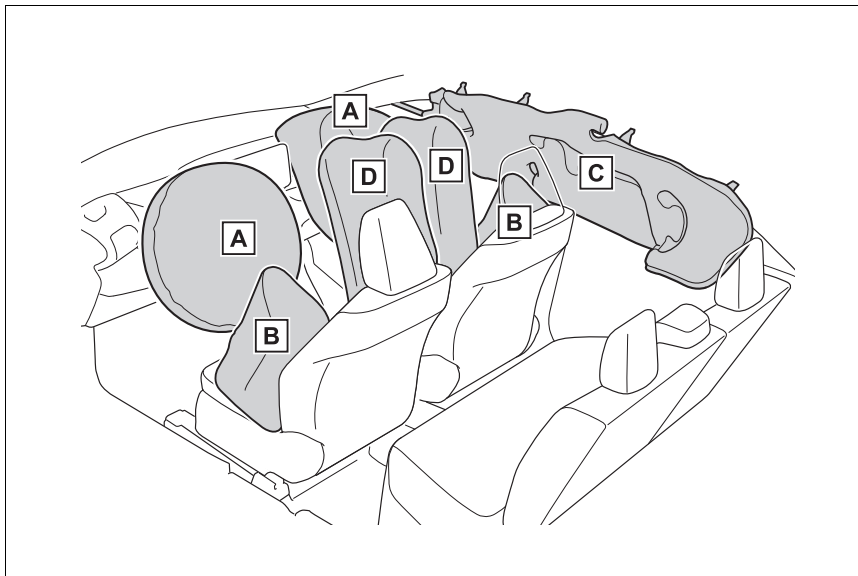

► SRS front airbags

A SRS driver airbag/front passenger airbag

Can help protect the head and chest of the driver and front passenger from impact with interior components

► SRS side and curtain shield airbags

B SRS front side airbags

Can help protect the torso of the front seat occupants

C SRS curtain shield airbags

Can help protect primarily the head of occupants in the outer seats

► Other SRS airbag

D SRS front seat center airbags

Can help protect the side head and neck of the front seat occupants

■ SRS airbag system components

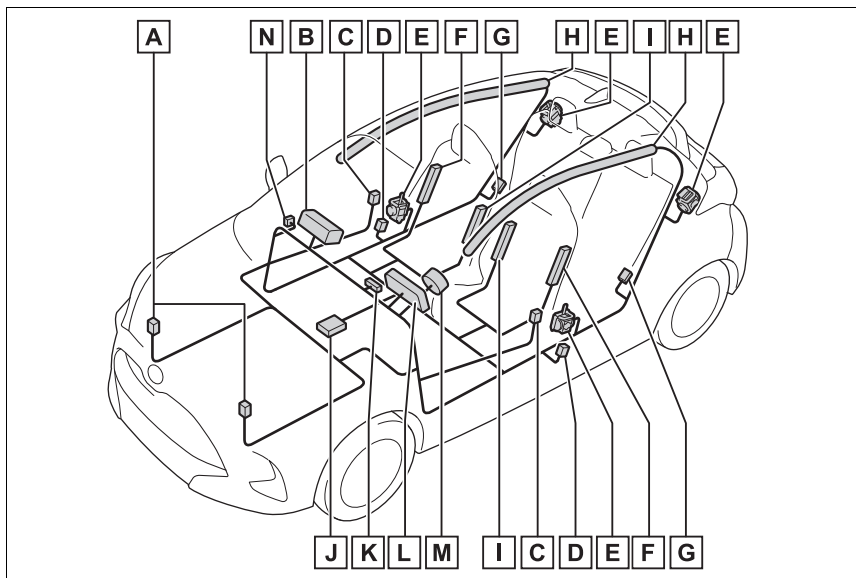

- A** Front impact sensors
- B** Front passenger airbag
- C** Side impact sensors (front door)
- D** Side impact sensors (front)
- E** Seat belt pretensioners and force limiters
- F** Side airbags
- G** Side impact sensors (rear)
- H** Curtain shield airbags
- I** Front seat center airbags
- J** Airbag sensor assembly
- K** "PASSENGER AIR BAG" indicator

L SRS warning light

M Driver airbag

N Airbag manual on-off switch

The main SRS airbag system components are shown above. The SRS airbag system is controlled by the airbag sensor assembly. As the airbags deploy, a chemical reaction in the inflators quickly fills the airbags with non-toxic gas to help restrain the motion of the occupants.

■ If the SRS airbags deploy (inflate)

- Slight abrasions, burns, bruising etc., may be sustained from SRS airbags, due to the extremely high speed deployment (inflation) by hot gases.
- A loud noise and white powder will be emitted.
- Parts of the airbag module (steering wheel hub, airbag cover and inflator) as well as the front seats, parts of the front and rear pillars, and roof side rails, may be hot for several minutes. The airbag itself may also be hot.
- The windshield may crack.
- The hybrid system will be stopped and fuel supply to the engine will be stopped. (→P.82)
- The brakes and stop lights will be controlled automatically. (→P.277)
- The interior lights will turn on automatically. (→P.296)
- The emergency flashers will turn on automatically. (→P.366)
- Vehicles with eCall: If any of the following situations occur, the system is designed to send an emergency call* to the eCall control center, notifying them of the vehicle's location (without needing to push the "SOS" button) and an agent will attempt to speak with the occupants to ascertain the level of emergency and assistance required. If the occupants are unable to communicate, the agent automatically treats the call as an emergency and helps to dispatch the necessary

emergency services. (→P.66)

- An SRS airbag is deployed.
- A seat belt pretensioner is activated.
- The vehicle is involved in a severe rear-end collision.

*: In some cases, the call cannot be made. (→P.67)

■ SRS airbag deployment conditions (SRS front airbags)

- The SRS front airbags will deploy in the event of an impact that exceeds the set threshold level (the level of force corresponding to an approximately 20 - 30 km/h [12 - 18 mph] frontal collision with a fixed wall that does not move or deform).

However, this threshold velocity will be considerably higher in the following situations:

- If the vehicle strikes an object, such as a parked vehicle or sign pole, which can move or deform on impact
- If the vehicle is involved in an under-ride collision, such as a collision in which the front of the vehicle "under-rides", or goes under, the bed of a truck

- Depending on the type of collision, it is possible that only the seat belt pretensioners will activate.

■ SRS airbag deployment conditions (SRS side and curtain shield airbags and SRS front seat center airbags)

- The SRS side and curtain shield airbags and SRS front seat center airbags will deploy in the event of an

impact that exceeds the set threshold level (the level of force corresponding to the impact force produced by an approximately 1500 kg [3300 lb.] vehicle colliding with the vehicle cabin from a direction perpendicular to the vehicle orientation at an approximate speed of 20 - 30 km/h [12 - 18 mph]).

- Both SRS curtain shield airbags may deploy in the event of a severe side collision.
- Both SRS curtain shield airbags may also deploy in the event of a severe frontal collision.

■ **Conditions under which the SRS airbags may deploy (inflate), other than a collision**

The SRS front airbags and SRS side and curtain shield airbags may also deploy if a serious impact occurs to the underside of your vehicle. Some examples are shown in the illustration.

- Hitting a curb, edge of pavement or hard surface
- Falling into or jumping over a deep hole
- Landing hard or falling

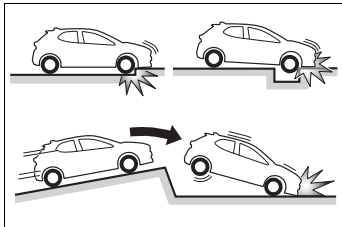

■ **Types of collisions that may not deploy the SRS airbags (SRS front airbags)**

The SRS front airbags do not generally inflate if the vehicle is involved in a side or rear collision, if it rolls over, or if it is involved in a low-speed frontal collision. But, whenever a collision of any type causes sufficient forward deceleration of the vehicle, deployment of the SRS front airbags may occur.

- Collision from the side

- Collision from the rear
- Vehicle rollover

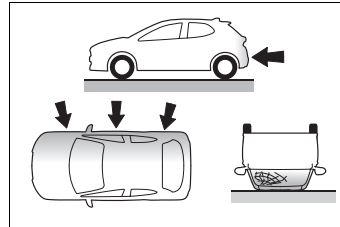

■ **Types of collisions that may not deploy the SRS airbags (SRS side and curtain shield airbags and SRS front seat center airbags)**

The SRS side and curtain shield airbags and SRS front seat center airbags may not activate if the vehicle is subjected to a collision from the side at certain angles, or a collision to the side of the vehicle body other than the passenger compartment.

- Collision from the side to the vehicle body other than the passenger compartment
- Collision from the side at an angle

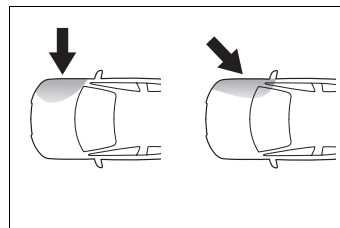

The SRS side airbags and SRS front seat center airbags do not generally inflate if the vehicle is involved in a frontal or rear collision, if it rolls over, or if it is involved in a low-speed side collision.

- Collision from the front
- Collision from the rear
- Vehicle rollover

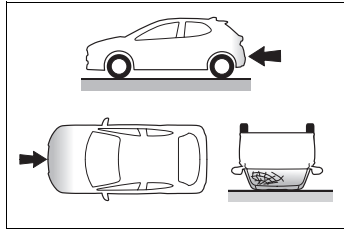

The SRS curtain shield airbags do not generally inflate if the vehicle is involved in a rear collision, if it rolls over, or if it is involved in a low-speed side or low-speed frontal collision.

- Collision from the rear
- Vehicle rollover

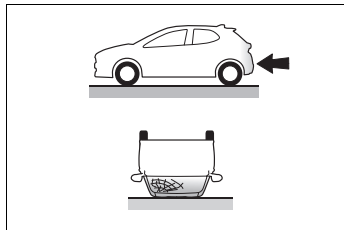

■ **When to contact any authorized Toyota retailer or Toyota authorized repairer, or any reliable repairer**

In the following cases, the vehicle will require inspection and/or repair. Contact any authorized Toyota retailer or Toyota authorized repairer, or any reliable repairer as soon as possible.

- Any of the SRS airbags have been inflated.
- The front of the vehicle is damaged or deformed, or was involved in an accident that was not severe enough to cause the SRS front airbags to inflate.

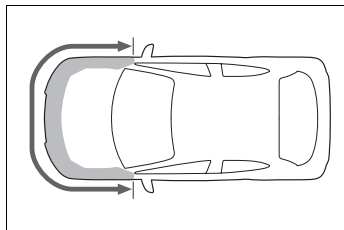

- A portion of a door or its surrounding

area is damaged, deformed or has had a hole made in it, or the vehicle was involved in an accident that was not severe enough to cause the SRS side and curtain shield airbags and SRS front seat center airbags to inflate.

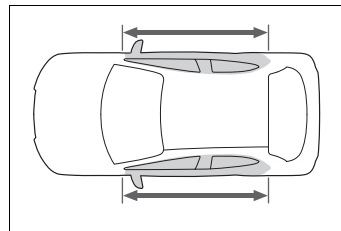

- The pad section of the steering wheel or dashboard near the front passenger airbag is scratched, cracked, or otherwise damaged.

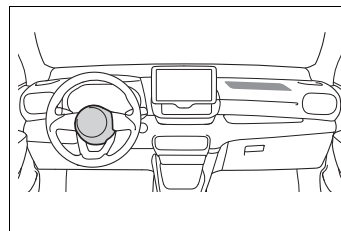

- The surface of the seats with the SRS side airbag and SRS front seat center airbag is scratched, cracked, or otherwise damaged.

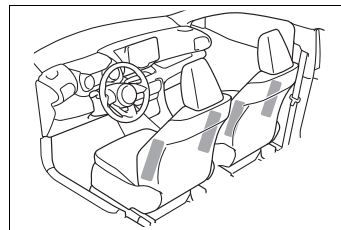

- The portion of the front pillars, rear pillars or roof side rail garnishes (padding) containing the SRS curtain shield airbags inside is scratched, cracked, or otherwise damaged.

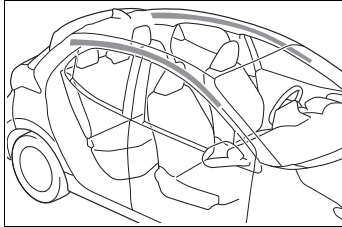

⚠ WARNING

■ SRS airbag precautions

Observe the following precautions regarding the SRS airbags. Failure to do so may cause death or serious injury.

- The driver and all passengers in the vehicle must wear their seat belts properly. The SRS airbags are supplemental devices to be used with the seat belts.
- The SRS driver airbag deploys with considerable force, and can cause death or serious injury especially if the driver is very close to the airbag.

Since the risk zone for the driver's airbag is the first 50 - 75 mm (2 - 3 in.) of inflation, placing yourself 250 mm (10 in.) from your driver airbag provides you with a clear margin of safety. This distance is measured from the center of the steering wheel to your breastbone. If you sit less than 250 mm (10 in.) away now, you can change your driving position in several ways:

- Move your seat to the rear as far as you can while still reaching the pedals comfortably.

- Slightly recline the back of the seat. Although vehicle designs vary, many drivers can achieve the 250 mm (10 in.) distance, even with the driver seat all the way forward, simply by reclining the back of the seat somewhat. If reclining the back of your seat makes it hard to see the road, raise yourself by using a firm, non-slippery cushion, or raise the seat if your vehicle has that feature.

- If your steering wheel is adjustable, tilt it downward. This points the airbag toward your chest instead of your head and neck.

The seat should be adjusted as recommended above, while still maintaining control of the foot pedals, steering wheel, and your view of the instrument panel controls.

- The SRS front passenger airbag also deploys with considerable force, and can cause death or serious injury especially if the front passenger is very close to the airbag. The front passenger seat should be as far from the airbag as possible with the seatback adjusted, so the front passenger sits upright.
- Improperly seated and/or restrained infants and children can be killed or seriously injured by a deploying airbag. An infant or child who is too small to use a seat belt should be properly secured using a child restraint system. Toyota strongly recommends that all infants and children be placed in the rear seats of the vehicle and properly restrained. The rear seats are safer for infants and children than the front passenger seat. (→P.47)

⚠ WARNING

- Do not sit on the edge of the seat or lean against the dashboard.

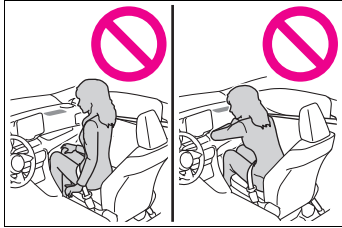

- Do not allow a child to stand in front of the SRS front passenger airbag unit or sit on the knees of a front passenger.

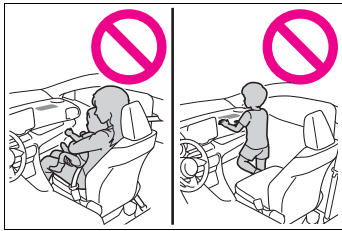

- Do not allow the front seat occupants to hold items on their knees.
- Do not lean against the door, the roof side rail or the front, side and rear pillars.

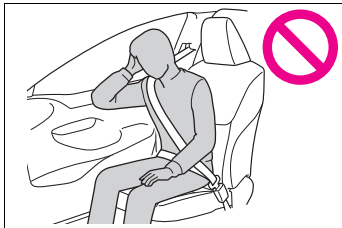

- Do not allow anyone to kneel on the passenger seat toward the door or put their head or hands outside the vehicle.

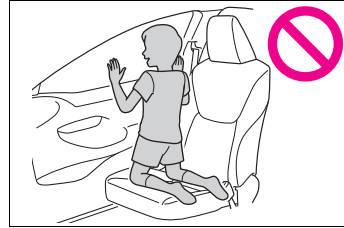

- Do not attach anything to or lean anything against areas such as the dashboard or steering wheel pad.

These items can become projectiles when the SRS driver and front passenger airbags deploy.

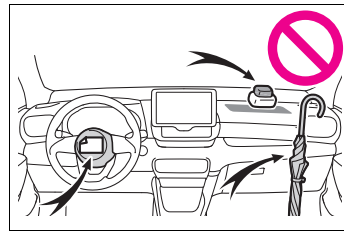

- Do not attach anything to areas such as a door, windshield, side windows, front or rear pillar, roof side rail and assist grip. (Except for the speed limit label →P.390)

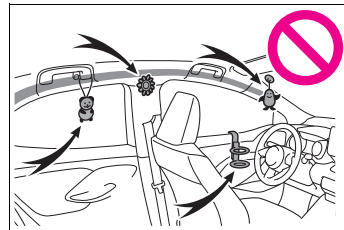

- Do not hang coat hangers or other hard objects on the coat hooks. All of these items could become projectiles and may cause death or serious injury, should the SRS curtain shield airbags deploy.

**WARNING**

- Do not use seat accessories which cover the parts where the SRS side airbags and SRS front seat center airbags inflate as they may interfere with inflation of the SRS airbags. Such accessories may prevent the SRS side airbags and SRS front seat center airbags from activating correctly, disable the system or cause the SRS side airbags and SRS front seat center airbags to inflate accidentally, resulting in death or serious injury.
- Do not strike or apply significant levels of force to the area of the SRS airbag components or the front doors. Doing so can cause the SRS airbags to malfunction.
- Do not touch any of the component parts immediately after the SRS airbags have deployed (inflated) as they may be hot.
- If breathing becomes difficult after the SRS airbags have deployed, open a door or window to allow fresh air in, or leave the vehicle if it is safe to do so. Wash off any residue as soon as possible to prevent skin irritation.
- If the areas where the SRS airbags are stored, such as the steering wheel pad and front and rear pillar garnishes, are damaged or cracked, have them replaced by any authorized Toyota retailer or Toyota authorized repairer, or any reliable repairer.

■ Modification and disposal of SRS airbag system components

Do not dispose of your vehicle or perform any of the following modifications without consulting your Toyota retailer or Toyota authorized repairer, or any reliable repairer. The SRS airbags may malfunction or deploy (inflate) accidentally, causing death or serious injury.

- Installation, removal, disassembly and repair of the SRS airbags
- Repairs, modifications, removal or replacement of the steering wheel, instrument panel, dashboard, seats or seat upholstery, front, side and rear pillars, roof side rails, front door panels, front door trims or front door speakers
- Modifications to the front door panel (such as making a hole in it)
- Repairs or modifications of the front fender, front bumper, or side of the occupant compartment
- Installation of a grille guard (bull bars, kangaroo bar, etc.), snow plows or winches
- Modifications to the vehicle's suspension system
- Installation of electronic devices such as mobile two-way radios (RF-transmitter) and CD players

Exhaust gas precautions

Harmful substance to the human body is included in exhaust gases if inhaled.

 **WARNING**

Exhaust gases include harmful carbon monoxide (CO), which is colorless and odorless. Observe the following precautions.

Failure to do so may cause exhaust gases enter the vehicle and may lead to an accident caused by light-headedness, or may lead to death or a serious health hazard.

■ Important points while driving

- Keep the back door closed.
- If you smell exhaust gases in the vehicle even when the back door is closed, open the windows and have the vehicle inspected at any authorized Toyota retailer or Toyota authorized repairer, or any reliable repairer as soon as possible.

■ When parking

- If the vehicle is in a poorly ventilated area or a closed area, such as a garage, stop the hybrid system.
- Do not leave the vehicle with the hybrid system on for a long time. If such a situation cannot be avoided, park the vehicle in an open space and ensure that exhaust fumes do not enter the vehicle interior.
- Do not leave the hybrid system operating in an area with snow build-up, or where it is snowing. If snowbanks build up around the vehicle while the hybrid system is operating, exhaust gases may collect and enter the vehicle.

■ Exhaust pipe

The exhaust system needs to be checked periodically. If there is a hole or crack caused by corrosion, damage to a joint or abnormal exhaust noise, be sure to have the vehicle inspected and repaired by any authorized Toyota retailer or Toyota authorized repairer, or any reliable repairer.

Airbag manual on-off system

This system deactivates the front passenger airbag. Only deactivate the airbag when using a child restraint system on the front passenger seat.

System components

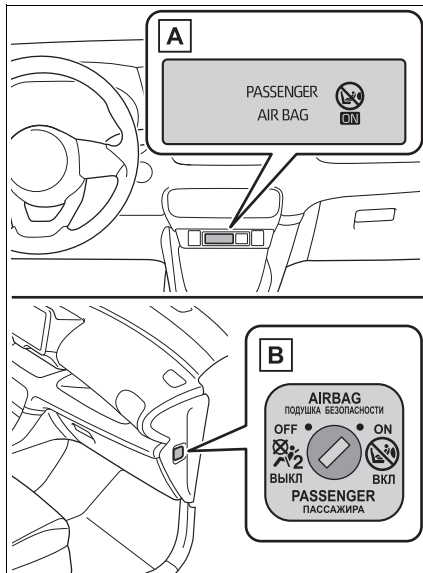

A "PASSENGER AIR BAG" indicator

"PASSENGER AIR BAG" and "ON" indicator light turns on when the airbag system is on, and about after 60 seconds they go off. (only when the power switch is in ON)

B Airbag manual on-off switch

Deactivating the front seat passenger airbag

Vehicles without a smart entry & start system: Insert the key into the cylinder and turn to the "OFF" position.

The "OFF" indicator light turns on (only when the power switch is in ON).

Vehicles with a smart entry & start system: Insert the mechanical key into the cylinder and turn to the "OFF" position.

The "OFF" indicator light turns on (only when the power switch is in ON).



"PASSENGER AIR BAG" indicator information

If any of the following problems occur, it is possible that there is a malfunction in the system. Have the vehicle inspected by any authorized Toyota retailer or Toyota authorized repairer, or any reliable repairer.

- The "OFF" indicator does not illuminate when the airbag manual on-off switch is set to "OFF".
- The indicator light does not change when the airbag manual on-off switch is switched to "ON" or "OFF".

**WARNING****■ When installing a child restraint system**

For safety reasons, always install a child restraint system in a rear seat. In the event that the rear seat cannot be used, the front seat can be used as long as the airbag manual on-off system is set to "OFF".

If the airbag manual on-off system is left on, the strong impact of the airbag deployment (inflation) may cause serious injury or even death.

■ When a child restraint system is not installed on the front passenger seat

Ensure that the airbag manual on-off system is set to "ON".

If it is left off, the airbag may not deploy in the event of an accident, which may result in serious injury or even death.

Riding with children

Observe the following precautions when children are in the vehicle.

Use a child restraint system appropriate for the child, until the child becomes large enough to properly wear the vehicle's seat belt.

- It is recommended that children sit in the rear seats to avoid accidental contact with the shift lever, wiper switch, etc.
- Use the rear door child-protector lock or the window lock switch to avoid children opening the door while driving or operating the power window accidentally. (→P.137, 158)
- Do not let small children operate equipment which may catch or pinch body parts, such as the power window, hood, back door, seats, etc.

**WARNING****■ When children are in the vehicle**

Never leave children unattended in the vehicle, and never allow children to have or use the key.

Children may be able to start the vehicle or shift the vehicle into neutral.

There is also a danger that children may injure themselves by playing with the windows or other features of the vehicle. In addition, heat build-up or extremely cold temperatures inside the vehicle can be fatal to children.

Child restraint systems

Before installing a child restraint system in the vehicle, there are precautions that need to be observed, different types of child restraint systems, as well as installation methods, etc., written in this manual.

- Use a child restraint system when riding with a small child that cannot properly use a seat belt. For the child's safety, install the child restraint system to a rear seat. Be sure to follow the installation method that is in the operation manual enclosed with the restraint system.
- The use of a Toyota genuine child restraint system is recommended, as it is safer to use in this vehicle. Toyota genuine child restraint systems are made specifically for Toyota vehicles. They can be purchased at a Toyota dealer.

Table of contents

Points to remember: P.47

When using a child restraint system: P.48

Child restraint system compatibility for each seating position: P.51

Child restraint system installation method: P.61

- Fixed with a seat belt: P.61
- Fixed with an ISOFIX lower anchorage: P.63
- Using a top tether anchorage: P.64

Points to remember

- Prioritize and observe the warnings, as well as the laws and regulations for child restraint systems.
- Use a child restraint system until the child becomes large enough to properly wear the vehicle's seat belt.
- Choose a child restraint system appropriate to the age and size of the child.
- Note that not all child restraint systems can fit in all vehicles. Before using or purchasing a child restraint system, check the compatibility of the child restraint system with seat positions. (→P.51)



WARNING

■ When a child is riding

Observe the following precautions. Failure to do so may result in death or serious injury.

1

For safety and security

**WARNING**

- For effective protection in automobile accidents and sudden stops, a child must be properly restrained, using a seat belt or child restraint system which is correctly installed. For installation details, refer to the operation manual enclosed with the child restraint system. General installation instruction is provided in this manual.
 - Toyota strongly urges the use of a proper child restraint system that conforms to the weight and size of the child, installed on the rear seat. According to accident statistics, the child is safer when properly restrained in the rear seat than in the front seat.
 - Holding a child in your or someone else's arms is not a substitute for a child restraint system. In an accident, the child can be crushed against the windshield or between the holder and the interior of the vehicle.
- **Handling the child restraint system**
- If the child restraint system is not properly fixed in place, the child or other passengers may be seriously injured or even killed in the event of sudden braking, sudden swerving, or an accident.
- If the vehicle were to receive a strong impact from an accident, etc., it is possible that the child restraint system has damage that is not readily visible. In such cases, do not reuse the restraint system.

- Depending on the child restraint system, installation may be difficult or impossible. In those cases, check whether the child restraint system is suitable for installment in the vehicle. (→P.51) Be sure to install and observe the usage rules after carefully reading the child restraint system fixing method in this manual, as well as the operation manual enclosed with the child restraint system.
- Keep the child restraint system properly secured on the seat even if it is not in use. Do not store the child restraint system unsecured in the passenger compartment.
- If it is necessary to detach the child restraint system, remove it from the vehicle or store it securely in the luggage compartment.

When using a child restraint system**■ When installing a child restraint system to a front passenger seat**

For the safety of a child, install a child restraint system to a rear seat. When installing a child restraint system to a front passenger seat is unavoidable, adjust the seat as follows and install the child restraint system:

- Move the front seat fully rearward.
- Adjust the seat height to the upper most position.
- Adjust the seatback angle to the most upright position.

When installing a forward-facing child

seat, if there is a gap between the child seat and the seatback, adjust the seat-back angle until good contact is achieved.

- If the head restraint interferes with your child restraint system, and the head restraint can be removed, remove the head restraint. Otherwise, put the head restraint in the upper most position.

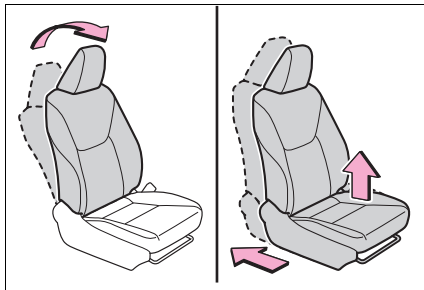

WARNING

■ When using a child restraint system

Observe the following precautions. Failure to do so may result in death or serious injury.

- Never use a rear-facing child restraint system on the front passenger seat when the airbag manual on-off switch is on. (→P.45) The force of the rapid inflation of the front passenger airbag can cause death or serious injury to children in the event of an accident.

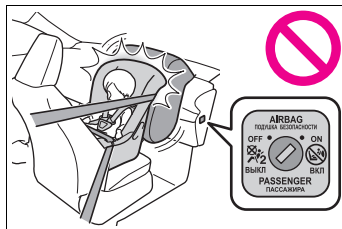

- There is a label(s) on the passenger side sun visor, indicating it is forbidden to attach a rear-facing child restraint system to the front passenger seat. Details of the label(s) are shown in the illustration below.

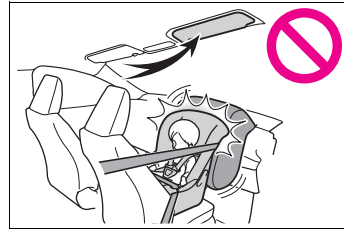

⚠ WARNING



⚠ WARNING

- Only put a forward-facing child restraint system on the front seat when unavoidable. When installing a forward-facing child restraint on the front passenger seat, move the seat as far back as possible. Failing to do so may result in death or serious injury if the airbags deploy (inflate).

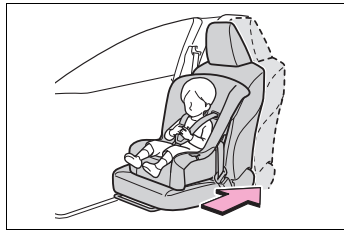

- Do not allow the child to lean his/her head or any part of his/her body against the door or the area of the seat, front or rear pillars, or roof side rails from which the SRS side airbags or SRS curtain shield airbags deploy even if the child is seated in the child restraint system. It is dangerous if the SRS side and curtain shield airbags inflate, and the impact could cause death or serious injury to the child.

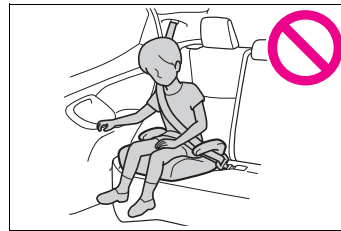

- When a junior seat is installed, always ensure that the shoulder belt is positioned across the center of the child's shoulder. The belt should be kept away from the child's neck, but not so that it could fall off the child's shoulder.

WARNING

- Use child restraint system suitable to the age and size of the child and install it to the rear seat.
- If the driver's seat interferes with the child restraint system and prevents it from being attached correctly, attach the child restraint system to the right-hand rear seat (left-hand drive vehicles) or the left-hand rear seat (right-hand drive vehicles). (→P.56)

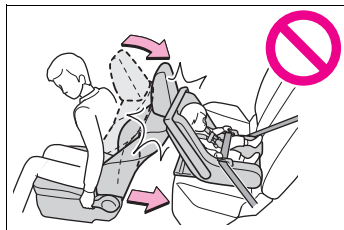
**Child restraint system compatibility for each seating position****Child restraint system compatibility for each seating position**

Compatibility of each seating position with child restraint systems (→P.52) displays the type of child restraint systems that can be used and possible seating positions for installation using symbols.

Also, the recommended child restraint system that is suitable for your child can be selected.

Otherwise, check [Recommended child restraint systems and Compatibility table] for recommended child restraint systems. (→P.56)

Check the selected child restraint system together with the following [Before confirming the compatibility of each seating position with child restraint systems].

Before confirming the compatibility of each seating position with child restraint systems**1 Checking the child restraint system standards.**

Use a child restraint system that conforms to UN (ECE) R44^{*1} or UN (ECE) R129^{*1, 2}.

The following approval mark is displayed on child restraint systems which are conformed.

Check for an approval mark attached to the child restraint system.

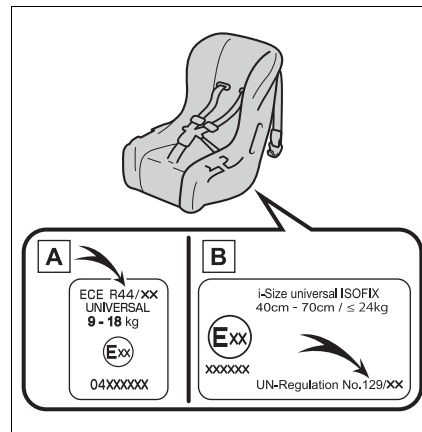

Example of the displayed regulation number

A UN (ECE) R44 approval mark^{*3}

The weight range of the child who is applicable for an UN (ECE) R44 approval mark is

indicated.

B UN (ECE) R129 approval mark^{*3}

The height range of the child who is applicable as well as available weights for an UN (ECE) R129 approval mark is indicated.

2 Checking the category of the child restraint system. Check the approval mark of the child restraint system for which of the following categories the child restraint system is suitable. Also, if there are any uncertainties, check the user’s guide included with the child restraint system or contact the retailer of the child restraint system.

- “universal”
- “semi-universal”
- “restricted”
- “vehicle specific”

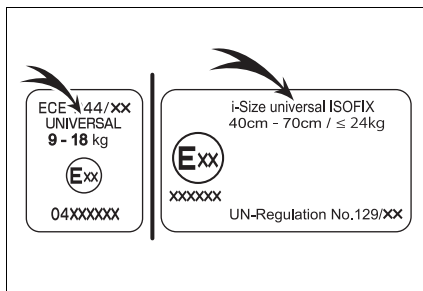

^{*1}: UN (ECE) R44 and UN (ECE) R129 are U.N. regulations for child restraint systems.

^{*2}: The child restraint systems mentioned in the table may not be available outside of the EU area.

^{*3}: The displayed mark may differ depending on the product.

Compatibility of each seating position with child restraint systems

▶ Left-hand drive vehicles

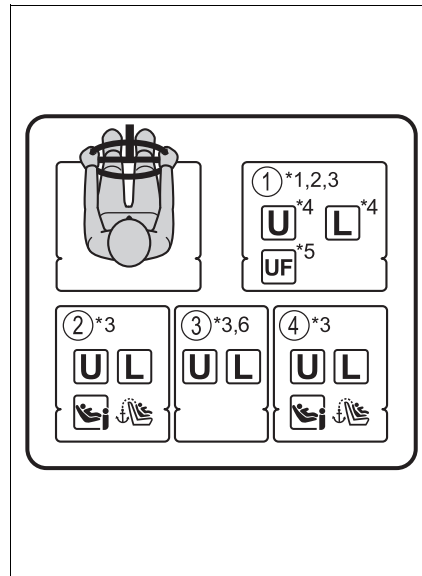

► Right-hand drive vehicles

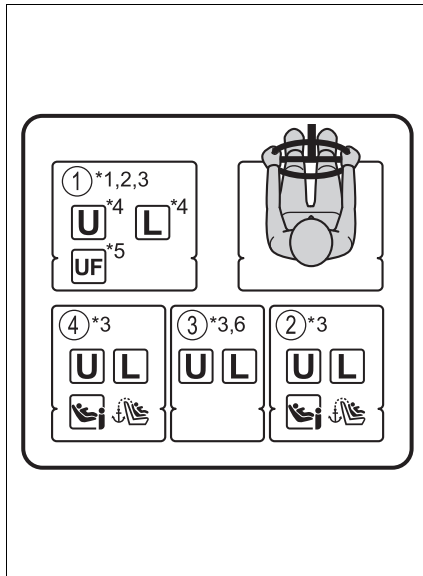

Suitable for “universal” category child restraint system fixed with the seat belt.



Suitable for forward-facing “Universal” category child restraints system fixed with the seat belt.



Suitable for child restraint systems given on recommended child restraint systems and compatibility table (→P.56).



Suitable for i-Size and ISOFIX child restraint system.



Includes a top tether anchorage point.

*1: Move the front seat fully rearward. If the passenger seat height can be adjusted, move it to the upper most position.

*2: Adjust the seatback angle to the most upright position. When installing a forward-facing child seat, if there is a gap between the child seat

and the seatback, adjust the seatback angle until good contact is achieved.

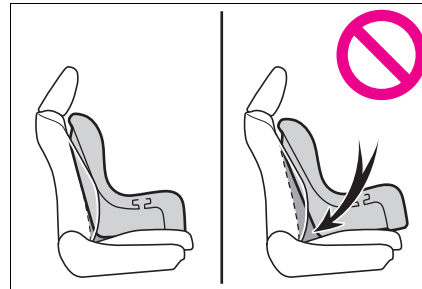

*3: If the head restraint interferes with your child restraint system, and the head restraint can be removed, remove the head restraint. Otherwise, put the head restraint in the upper most position.





*4: Deactivation of front passenger airbag.



*5: Activation of front passenger airbag. Never use a rear-facing child restraint system on the front passenger seat when the airbag manual on-off switch is on.

*6: Not suitable for child restraint systems with support leg.

■ Detail information for child restraint systems installation

Seating position					
Seat position number	①		②	③	④
	Airbag manual on-off switch				
	ON	OFF			
					
Seating position suitable for universal belted (Yes/No) ^{*1}	Yes Forward-facing only	Yes	Yes	Yes ^{*2}	Yes
i-Size seating position (Yes/No)	No	No	Yes	No	Yes
Seating position suitable for lateral fixture (L1/L2/No)	No	No	No	No	No
Suitable rearward facing fixture (R1/R2X/R2/R3/No)	No	No	R1, R2X, R2, R3 ^{*3}	No	R1, R2X, R2, R3 ^{*4}
Suitable forward facing fixture (F2X/F2/F3/No)	No	No	F2X, F2, F3	No	F2X, F2, F3
Suitable junior seat fixture (B2/B3/No)	No	No	B2, B3	No	B2, B3

*1: All Universal categories (group 0, 0+, I, II and III).

*2: Not suitable for child restraint systems with support leg.

*3: Adjust the driver's seat to the highest position.

*4: Before installing a child restraint system to this seat, adjust the position of the front passenger's seat to between the 1st lock position and 12th lock position (16th lock position from the rear).

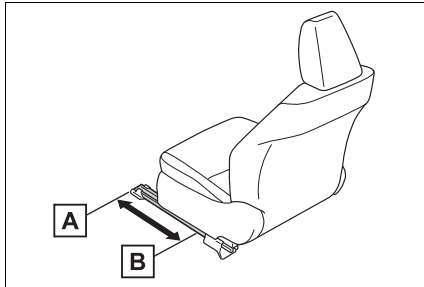

A 1st lock position

B 12th lock position

ISOFIX child restraint systems are divided into different “fixture”. The child restraint system can be used in the seating positions for “fixture” mentioned in the table above. For kind of “fixture” relation, confirm the following table. If your child restraint system has no kind of “fixture” (or if you cannot find information in the table below), please refer to the child restraint system “vehicle list” for compatibility information or ask the retailer of your child seat.



Mass groups	Child weight	Size class	Fixture	Description
0	up to 10 kg (22 lb.)	E	R1	Rearward-facing infant seat
		F	L1	Left lateral-facing infant seat (Carycot)
		G	L2	Right lateral-facing infant seat (Carycot)
0+	up to 13 kg (28 lb.)	C	R3	Full-size, rearward-facing child restraint systems
		D	R2	Reduced-size, rearward-facing child restraint systems
		—	R2X	Reduced-size, rearward-facing child restraint systems
		E	R1	Rearward-facing infant seat

Mass groups	Child weight	Size class	Fixture	Description
I	9 to 18 kg (20 to 39 lb.)	A	F3	Full-height, forward-facing child restraint systems
		B	F2	Reduced-height, forward-facing child restraint systems
		B1	F2X	Reduced-height, forward-facing child restraint systems
		C	R3	Full-size, rearward-facing child restraint systems
		D	R2	Reduced-size, rearward-facing child restraint systems
II	15 to 25 kg (34 to 55 lb.)	—	B2, B3	Junior seat
III	22 to 36 kg (48 to 79 lb.)			

■ Recommended child restraint systems and Compatibility table

► Recommended child restraint system fixed with a seat belt

Recommended Child Restraint System	Mass groups	Seating position				
		①		②	③	④
		Airbag manual on-off switch				
		ON	OFF			
G0+, BABY SAFE PLUS	0, 0+ Up to 13 kg (28 lb.)	X	U	U	U	U
DUO PLUS	I 9 to 18 kg (20 to 39 lb.)	UF	UF	UF	X	UF

Recommended Child Restraint System	Mass groups	Seating position				
		1		2	3	4
		Airbag manual on-off switch				
		ON	OFF			
						
KIDFIX XP SICT	II 15 to 25 kg (34 to 55 lb.)	U	U	U	X	U
KIDFIX II S*		U	U	U	X	U
MAXI PLUS		U	U	U	X	U
KIDFIX XP SICT	III 22 to 36 kg (48 to 79 lb.)	U	U	X	X	X
KIDFIX II S*		U	U	X	X	X
MAXI PLUS		U	U	U	X	U

*: Be sure to attach the seat belt through the SecureGuard.

Key of letters inserted in the above table:

U: Suitable position for recommended child restraint system of “Universal” category

UF: Suitable position for recommended forward-facing child restraint system of “Universal” category

X: Not suitable position

The child restraint systems mentioned in the table may not be available outside the EU area.

- Recommended child restraint system fixed with an ISOFIX lower anchorage

Recommended Child Restraint System	Mass groups	Seating position				
		1		2	3	4
		Airbag manual on-off switch				
		ON	OFF			
G0+, BABY SAFE PLUS	0, 0+ Up to 13 kg (28 lb.)	X	X	X	X	X
DUO PLUS	I 9 to 18 kg (20 to 39 lb.)	X	X	IUF	X	IUF
KIDFIX XP SICT	II 15 to 25 kg (34 to 55 lb.)	X	X	IL	X	IL
KIDFIX II S*		X	X	IL	X	IL
MAXI PLUS		X	X	IL	X	IL
MAXI PLUS	III 22 to 36 kg (48 to 79 lb.)	X	X	IL	X	IL

*: Be sure to attach the seat belt through the SecureGuard.

Key of letters inserted in the above table:

IUF: Suitable position for recommended ISOFIX forward-facing child restraint system of “Universal” category

IL: Suitable position for recommended ISOFIX forward-facing child restraint system of “Semi-universal” category



X: Not suitable position for recommended ISOFIX forward-facing child restraint system

The child restraint systems mentioned in the table may not be available outside the EU area.

- ▶ i-Size child restraint system fixed with an ISOFIX lower anchorage

If your child restraint system is “i-Size” category, you can install it on the positions mentioned by i-U in the table below.

Child restraint system category can be found in the restraint system manual.

	Seating position				
	①		②	③	④
	Airbag manual on-off switch				
	ON	OFF			
					
i-Size Child Restraint System	X	X	i-U	X	i-U

Key of letters inserted in the above table:

i-U: Suitable position for i-Size child restraint system forward-facing and/or rearward-facing

X: Not suitable position for i-Size child restraint system

When securing some types of child restraint systems in rear seat, it may not be possible to properly use the seat belts in positions next to the child restraint without interfering with it or affecting seat belt effectiveness. Be sure your seat belt fits snugly across your shoulder and low on your hips. If it does not, or if it interferes with the child restraint, move to a different position. Failure to do so may result in death or serious injury.

- When installing a child restraint in the rear seats, adjust the front seat so that it does not interfere with the child or child restraint

system.

- When installing a child seat with support base, if the child seat interferes with the seatback when latching it into the support base, adjust the seatback rearward until there is no interference.
- If the seat belt shoulder anchor is ahead of the child seat belt guide, move the seat cushion forward.

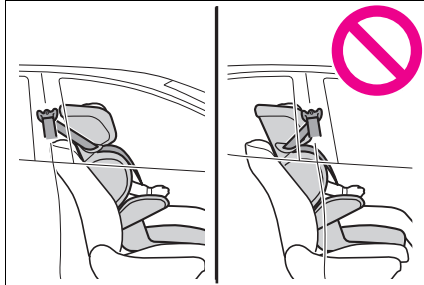

- When installing a junior seat, if the child in your child restraint system is in a very upright position, adjust the seatback angle to the most comfortable position. And if the seat belt shoulder anchor is ahead of the child seat belt guide, move the seat cushion forward.
- When using the child restraint system with SecureGuard, be sure to guide the lap belt into SecureGuard **A** as shown in the illustration.

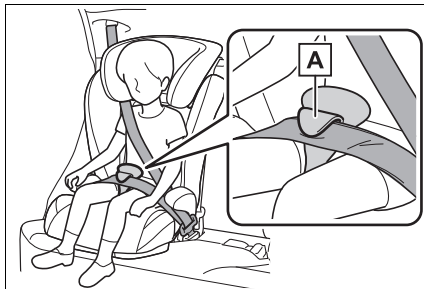

Child restraint system installation method

Confirm with the operation manual enclosed with the child restraint system about the installation of the child restraint system.

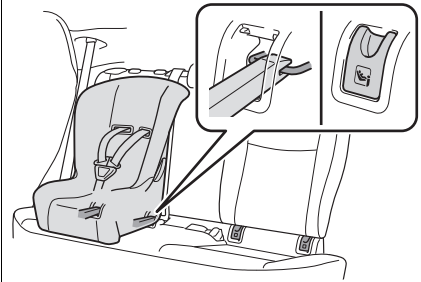
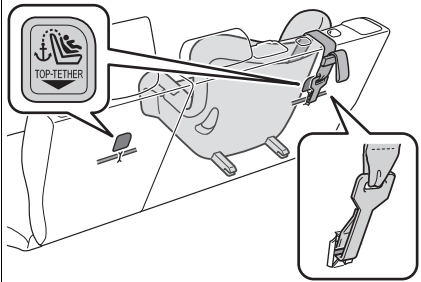
	Installation method	Page
Seat belt attachment		P.61
ISOFIX lower anchorage attachment		P.63
Top tether anchorage attachment		P.64

Child restraint system fixed with a seat belt

■ Installing child restraint system using a seat belt

Install the child restraint system in

accordance to the operation manual enclosed with the child restraint system.

If the child restraint system on hand is not within the “universal” category (or the necessary information

is not in the table), refer to the “Vehicle List” provided by the child restraint system maker for various possible installation positions, or check the compatibility after asking the retailer of the child seat. (→P.51, 52)

- 1 If installing the child restraint system to the front passenger seat is unavoidable, refer to P.48 for the front passenger seat adjustment.
- 2 If the head restraint interferes with your child restraint system, and the head restraint can be removed, remove the head restraint. Otherwise, put the head restraint in the upper most position. (→P.147)
- 3 Run the seat belt through the child restraint system and insert the plate into the buckle. Make sure that the belt is not twisted. Securely fix the seat belt to the child restraint system in accordance to the directions enclosed with the child restraint system.

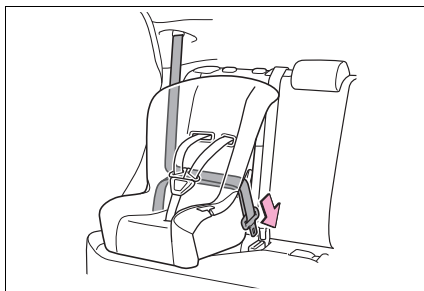

- 4 If your child restraint system is not equipped with a lock-off (a

seat belt locking feature), secure the child restraint system using a locking clip.

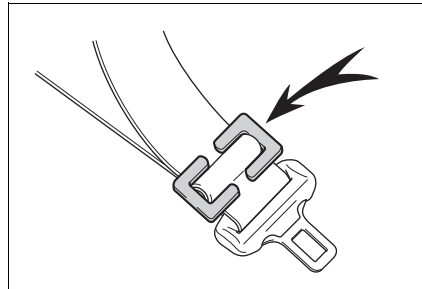

- 5 After installing the child restraint system, rock it back and forth to ensure that it is installed securely. (→P.63)

■ **Removing a child restraint system installed with a seat belt**

Press the buckle release button and fully retract the seat belt.

When releasing the buckle, the child restraint system may spring up due to the rebound of the seat cushion. Release the buckle while holding down the child restraint system.

Since the seat belt automatically reels itself, slowly return it to the stowing position.

■ **When installing a child restraint system**

You may need a locking clip to install the child restraint system. Follow the instructions provided by the manufacturer of the system. If your child restraint system does not provide a locking clip, you can purchase the following item from any authorized Toyota retailer or Toyota authorized repairer, or any reliable repairer: Locking clip for child restraint system

(Part No. 73119-22010)

⚠ WARNING**■ When installing a child restraint system**

Observe the following precautions. Failure to do so may result in death or serious injury.

- Do not allow children to play with the seat belt. If the seat belt becomes twisted around a child's neck, it may lead to choking or other serious injuries that could result in death. If this occurs and the buckle cannot be unfastened, scissors should be used to cut the belt.
- Ensure that the belt and plate are securely locked and the seat belt is not twisted.
- Shake the child restraint system left and right, and forward and backward to ensure that it has been securely installed.
- After securing a child restraint system, never adjust the seat.
- When a junior seat is installed, always ensure that the shoulder belt is positioned across the center of the child's shoulder. The belt should be kept away from the child's neck, but not so that it could fall off the child's shoulder.
- Follow all installation instructions provided by the child restraint system manufacturer.

Child restraint system fixed with an ISOFIX lower anchorage**■ ISOFIX lower anchorages (ISOFIX child restraint system)**

Lower anchorages are provided for

the outboard rear seats. (Marks displaying the location of the anchorages are attached to the seats.)

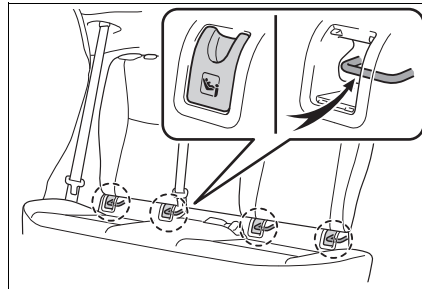
**■ Installation with ISOFIX lower anchorage (ISOFIX child restraint system)**

Install the child restraint system in accordance to the operation manual enclosed with the child restraint system.

If the child restraint system on hand is not within the "universal" category (or the necessary information is not in the table), refer to the "Vehicle List" provided by the child restraint system maker for various possible installation positions, or check the compatibility after asking the retailer of the child seat.

(→P.51, 52)

- 1 If the head restraint interferes with your child restraint system, and the head restraint can be removed, remove the head restraint. Otherwise, put the head restraint in the upper most position. (→P.147)
- 2 Remove the anchorage covers, and install the child restraint system to the seat.

1

For safety and security

The bars are installed behind the anchorage covers.



- 3 After installing the child restraint system, rock it back and forth to ensure that it is installed securely. (→P.63)

⚠ WARNING

■ **When installing a child restraint system**

Observe the following precautions. Failure to do so may result in death or serious injury.

- After securing a child restraint system, never adjust the seat.
- When using the lower anchorages, be sure that there are no foreign objects around the anchorages and that the seat belt is not caught behind the child restraint system.
- Follow all installation instructions provided by the child restraint system manufacturer.

Using a top tether anchorage

■ **Top tether anchorages**

Top tether anchorages are provided

for the outboard rear seats.

Use top tether anchorages when fixing the top strap.

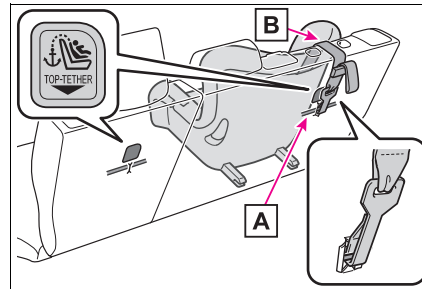

- A** Top tether anchorages
- B** Top strap

■ **Fixing the top strap to the top tether anchorage**

Install the child restraint system in accordance to the operation manual enclosed with the child restraint system.

- 1 Vehicles with the tonneau cover: Remove the tonneau cover. (→P.302)
- 2 Adjust the head restraint to the upmost position.

If the head restraint interferes with the child restraint system or top strap installation and the head restraint can be removed, remove the head restraint. (→P.147)

- 3 Latch the hook onto the top tether anchorage and tighten the top strap.

Make sure the top strap is securely latched. (→P.63)

When installing the child restraint system with the head restraint being raised, be sure to have the top strap

pass underneath the head restraint.

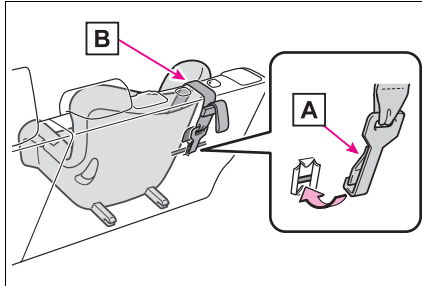

A Hook

B Top strap

- 4 Vehicles with the tonneau cover:
Reinstall the tonneau cover.



WARNING

■ When installing a child restraint system

Observe the following precautions. Failure to do so may result in death or serious injury.

- Firmly attach the top strap and make sure that the belt is not twisted.
- Do not attach the top strap to anything other than the top tether anchorage.
- After securing a child restraint system, never adjust the seat.
- Follow all installation instructions provided by the child restraint system manufacturer.
- When installing the child restraint system with the head restraint being raised, after the head restraint has been raised and then the top tether anchorage has been fixed, do not lower the head restraint.

eCall^{*1, 2}

*1: If equipped

*2: Operates within the eCall coverage.
The system name differs depending on the country.

eCall is a telematics service that uses Global Navigation Satellite System (GNSS) data and embedded cellular technology to enable the following emergency calls to be made: Automatic emergency calls (Automatic Collision Notification) and manual emergency calls (by pressing the “SOS” button). This service is required by European Union Regulations.

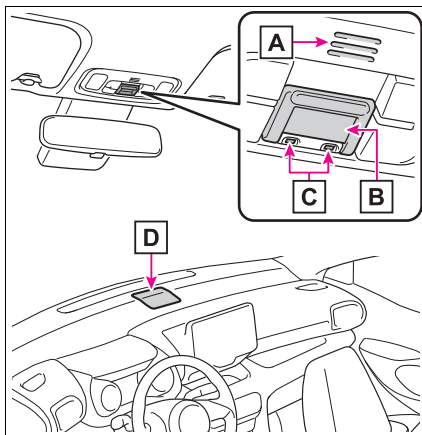
System components

A Microphone

B “SOS” button *

C Indicator lights

D Speaker

*: This button is intended for communication with the eCall system operator. Other SOS buttons available in other systems of a motor vehicle do not relate to the device and are not intended for communication with the eCall system operator.

Emergency Notification Services**Automatic Emergency Calls**

If any airbag deploys, the system is designed to automatically call the eCall control center.* The answering operator receives the vehicle's location, the time of the incident and the vehicle VIN, and attempts to speak with the vehicle occupants to assess the situation. If the occupants are unable to communicate, the operator automatically treats the call as an emergency and contacts the nearest emergency services provider (112 system etc.) to describe the situation and request that assistance be sent to the location.

*: In some cases, the call cannot be made. (→P.67)

Manual Emergency Calls

In the event of an emergency, press the “SOS” button to call the eCall control center.* The answering operator will determine your vehicle's location, assess the situation, and dispatch the necessary assis-

tance required.

Make sure to open the cover before pressing the “SOS” button.

If you accidentally press the “SOS” button, tell the operator that you are not experiencing an emergency.

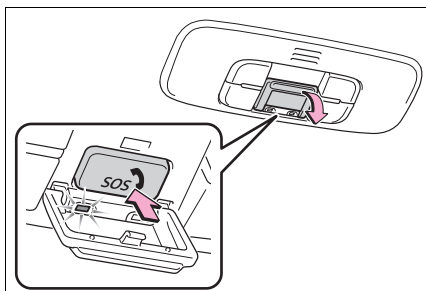

*: In some cases, the call cannot be made. (→P.67)

Indicator lights

When the power switch is turned to ON, the red indicator light will illuminate for 10 seconds and then the green indicator light will illuminate, indicating that the system is enabled. The indicator lights indicate the following:

- If the green indicator light illuminates and stays on, the system is enabled.
- If the green indicator light flashes twice per second, an automatic or manual Emergency Call is being made.
- If the red indicator light illuminates at any time other than immediately after the power switch is turned to ON, the system may be malfunctioning or

the backup battery may be depleted.

- If the red indicator light blinks for approximately 30 seconds during an Emergency Call, the call has been disconnected or the cellular network signal is weak.

The service life of the backup battery does not exceed 3 years.

⚠ WARNING

■ When the Emergency Call may not be made

- It may not be possible to make Emergency Calls in any of the following situations. In such cases, report to emergency services provider (112 system etc.) by other means such as nearby public phones.
 - Even when the vehicle is in the cellular phone service area, it may be difficult to connect to the eCall control center if the reception is poor or the line is busy. In such cases, even though the system attempts to connect to the eCall control center, you may not be able to connect to the eCall control center to make Emergency Calls and contact emergency services.
 - When the vehicle is out of the cellular phone service area, the Emergency Calls cannot be made.
 - When any related equipment (such as the “SOS” button panel, indicator lights, microphone, speaker, DCM, antenna, or any wires connecting the equipment) is malfunctioning, damaged or broken, the Emergency Call cannot be made.

**WARNING**

- During an Emergency Call, the system makes repeated attempts to connect to the eCall control center. However, if it cannot connect to the eCall control center due to poor radio wave reception, the system may not be able to connect to the cellular network and the call may finish without connecting. The red indicator light will blink for approximately 30 seconds to indicate this disconnection.
- If the 12-volt battery's voltage decreases or there is a disconnection, the system may not be able to connect to the eCall control center.
- The Emergency Call system might not work outside of EU area, depending on the available infrastructure in the country.

■ When the Emergency Call system is replaced with a new one

The Emergency Call system should be registered. Contact any authorized Toyota retailer or Toyota authorized repairer, or any reliable repairer.

■ For your safety

- Please drive safely.
The function of this system is to assist you in making the Emergency Call in case of accidents such as traffic accidents or sudden medical emergencies, and it does not protect the driver or passengers in any way. Please drive safely and fasten your seatbelts at all times for your safety.
- In case of an emergency, make lives the top priority.
- If you smell anything burning or other unusual smells, leave the vehicle and evacuate to a safe area immediately.

- If the airbags deploy when the system is operating normally, the system makes emergency call. The system also makes emergency call when the vehicle is struck from the rear or rolls over, even if the airbags do not deploy.
- For safety, do not make the Emergency Call while driving.
Making calls during driving may cause mishandling of the steering wheel, which may lead to unexpected accidents.
Stop the vehicle and confirm the safety of your surroundings before making the Emergency Call.
- When changing fuses, please use the specified fuses. Using other fuses may cause ignition or smoke in the circuit and lead to a fire.
- Using the system while there is smoke or an unusual smell may cause a fire. Stop using the system immediately and consult any authorized Toyota retailer or Toyota authorized repairer, or any reliable repairer.

**NOTICE****■ To prevent damage**

Do not pour any liquids onto the "SOS" button panel, etc. and do not impact it.

■ If the "SOS" button panel, speaker or microphone malfunctions during an Emergency Call or manual maintenance check

It may not be possible to make Emergency Calls, confirm the system status, or communicate with the eCall control center operator. If any of the above equipment is damaged, please consult any authorized Toyota retailer or Toyota authorized repairer, or any reliable repairer.

System overview of added service

■ Data processing flow

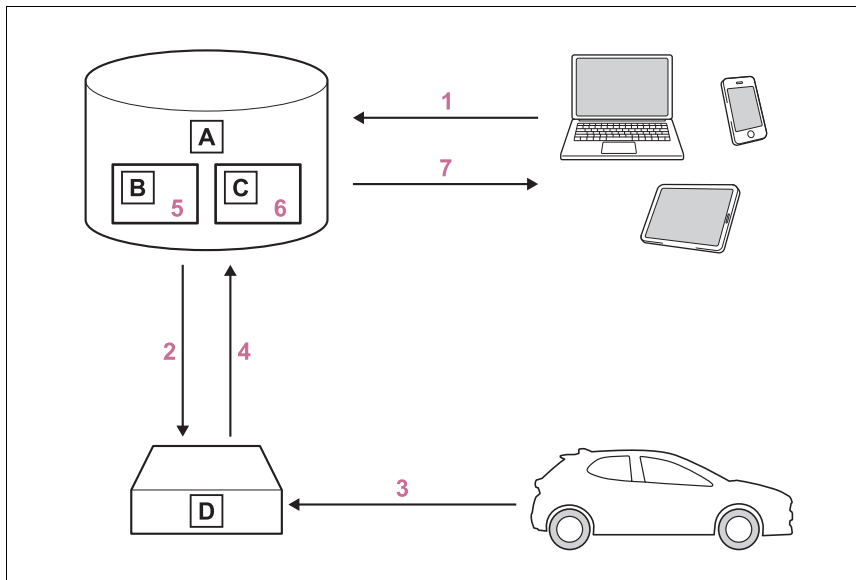

A Server

B Storage

C Processing

D DCM

- 1** Activation of data sharing is done by enabling a service on the “MyT by Toyota” app or purchasing a service that requires data collection.
- 2** Server activates the service in the DCM and defines which vehicle data to collect.
- 3** Defined vehicle data is collected by the DCM.
- 4** Data is shared with the server.
- 5** Data is stored in the server.
- 6** Data is processed in the server for fulfilling the service.
- 7** Processed data is presented to the customer.

For a list of eligible services in your region please visit the Toyota website or contact any authorized Toyota retailer or Toyota authorized repairer, or any reliable repairer.

Implementing Regulation

Implementing Regulation Annex1 PART3 User Information			Conformity
1. DESCRIPTION OF THE ECALL IN-VEHICLE SYSTEM			
1.1.	Overview of the 112-based eCall in-vehicle system, its operation and functionalities		○
1.2.	The 112-based eCall service is a public service of general interest and is accessible free of charge.		○
1.3.	The 112-based eCall in-vehicle system is activated by default. It is activated automatically by means of in-vehicle sensors in the event of a severe accident. It will also be triggered automatically when the vehicle is equipped with a TPS system which does not function in the event of a severe accident.		○
1.4.	The 112-based eCall in-vehicle system can also be triggered manually, if needed. Instructions for manual activation of the system		○
1.5.	In the event of a critical system failure that would disable the 112-based eCall in-vehicle system, the following warning will be given to the occupants of the vehicle		○

Implementing Regulation Annex1 PART3 User Information		Conformity
2. INFORMATION ON DATA PROCESSING		
2.1.	Any processing of personal data through the 112-based eCall in-vehicle system shall comply with the personal data protection rules provided for in Directives 95/46/EC and 2002/58/EC, and in particular, shall be based on the necessity to protect the vital interests of the individuals in accordance with Article 7(d) of Directive 95/46/EC.	O
2.2.	Processing of such data is strictly limited to the purpose of handling the emergency eCall to the single European emergency number 112.	O
2.3. Types of data and its recipients		
2.3.1.	The 112-based eCall in-vehicle system may collect and process only the following data: Vehicle Identification Number, Vehicle type (passenger vehicle or light commercial vehicle), Vehicle propulsion storage type (gasoline/diesel/CNG/LPG/electric/hydrogen), Vehicle last three locations and direction of travel, Log file of the automatic activation of the system and its timestamp, Any additional data (if applicable)	O
2.3.2.	Recipients of data processed by the 112-based eCall in-vehicle system are the relevant public safety answering points designated by the respective public authorities of the country on which territory they are located, to first receive and handle eCalls to the single European emergency number 112. Additional information (if available):	O

Implementing Regulation Annex1 PART3 User Information		Conformity
2.4. Arrangements for data processing		
2.4.1.	The 112-based eCall in-vehicle system is designed in such a way as to ensure that the data contained in the system memory is not available outside the system before an eCall is triggered. Additional remarks (if any):	O
2.4.2.	The 112-based eCall in-vehicle system is designed in such a way as to ensure that it is not traceable and not subject to any constant tracking in its normal operation status. Additional remarks (if any):	O
2.4.3.	The 112-based eCall in-vehicle system is designed in such a way as to ensure that data in the system internal memory is automatically and continuously removed.	O
2.4.3.1.	The vehicle location data is constantly overwritten in the internal memory of the system so as always to keep maximum of the last three up-to-date locations of the vehicle necessary for the normal functioning of the system.	O
2.4.3.2.	The log of activity data in the 112-based eCall in-vehicle system is kept for no longer than necessary for attaining the purpose of handling the emergency eCall and in any case not beyond 13 hours from the moment an emergency eCall was initiated.	O

Implementing Regulation Annex1 PART3 User Information		Conformity
2.5. Modalities for exercising data subject's rights		
2.5.1.	The data subject (the vehicle's owner) has a right of access to data and as appropriate to request the rectification, erasure or blocking of data, concerning him or her, the processing of which does not comply with the provisions of Directive 95/46/EC. Any third parties to whom the data have been disclosed have to be notified of such rectification, erasure or blocking carried out in compliance with this Directive, unless it proves impossible or involves a disproportionate effort.	O
2.5.2.	The data subject has a right to complain to the competent data protection authority if he or she considers that his or her rights have been infringed as a result of the processing of his or her personal data.	O
2.5.3.	Contact service responsible for handling access requests (if any): →P.74	O

74 1-3. Emergency assistance

Implementing Regulation Annex1 PART3 User Information		Conformity
3. INFORMATION ON THIRD PARTY SERVICES AND OTHER ADDED VALUE SERVICES (IF FITTED)		
3.1.	Description of the operation and the functionalities of the TPS system/added value service	→P.69
3.2.	Any processing of personal data through the TPS system/other added value service shall comply with the personal data protection rules provided for in Directives 95/46/EC and 2002/58/EC.	O
3.2.1.	Legal basis for the use of TPS system and/or added value services and for processing data through them	The European Union General Data Protection Regulation
3.3.	The TPS system and/or other added value services shall process personal data only on the base of the explicit consent of the data subject (the vehicle's owner or owners).	O
3.4.	Modalities for data processing through TPS system and/or other added value services, including any necessary additional information regarding traceability, tracking and processing of personal data	→P.69
3.5.	The owner of a vehicle equipped with a TPS eCall system and/or other added value service in addition to the 112-based eCall in-vehicle system has the right to choose to use the 112-based eCall in-vehicle system rather than the TPS eCall system and the other added value service.	O
3.5.1.	Contact details for handling TPS eCall system deactivation requests	N/A

■ Service responsible for handling access requests

Country	Contact information
Austria	datenschutz@toyota-frey.at
Belgium/Luxembourg	privacy@toyota.be

Country	Contact information
Croatia	dpcp@toyota.hr
Czech Republic/ Hungary/Slovakia	adatvedelem@toyota-ce.com
Denmark	toyota@toyota.dk og
Estonia	privacy@toyota.ee
Finland	tietosuoja@toyota.fi
France	delegue.protectiondonnees@toyota-europe.com
Germany	Toyota.Datenschutz@toyota.de
Great Britain	privacy@tgb.toyota.co.uk
Greece	customer@toyota.gr
Iceland	personuvernd@toyota.is
Ireland	customerservice@toyota.ie
Italy	tmi.dpo@toyota-europe.com
Netherlands	www.toyota.nl/klantenservice
Norway	personvern@toyota.no
Poland	klient@toyota.pl
Portugal	gestaodadospessoais@toyotacaetano.pt
Romania	relatii.clienti@toyota.ro
Slovenia	dpcp@toyota.si
Spain	clientes@toyota.es / dpo@toyota.es.
Sweden	integritet@toyota.se
Switzerland	info@toyota.ch

■ Free/Open Source Software Information

This product contains Free/Open Source Software (FOSS). The license information and/or the source code of such FOSS can be found at the following URL.

<http://www.opensourceautomotive.com/dcm/toyota/>

■ Certification for eCall

→P.441

Hybrid system features

Your vehicle is a hybrid vehicle. It has characteristics different from conventional vehicles. Be sure you are closely familiar with the characteristics of your vehicle, and operate it with care.

The hybrid system combines the use of a gasoline engine and an electric motor (traction motor) according to driving conditions, improving fuel efficiency and reducing exhaust emissions.

System components

■ System components

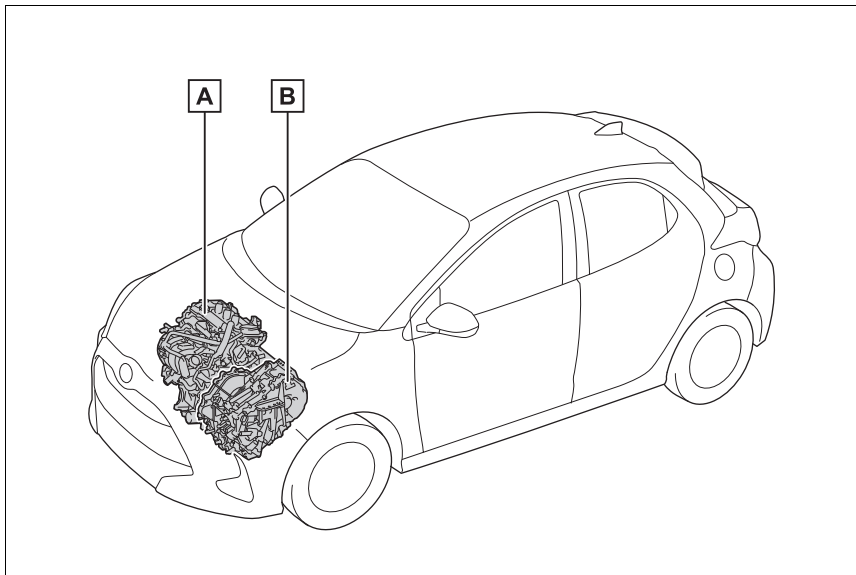

The illustration is an example for explanation and may differ from the actual item.

A Gasoline engine

B Electric motor (traction motor)

■ When stopped/during start off

The gasoline engine stops* when the vehicle is stopped. During start off, the electric motor (traction motor) drives the vehicle. At slow

speeds or when traveling down a gentle slope, the engine is stopped* and the electric motor (traction motor) is used.

When the shift lever is in N, the

hybrid battery (traction battery) is not being charged.

*: When the hybrid battery (traction battery) requires charging or the engine is warming up, etc., the gasoline engine will not automatically stop. (→P.77)

■ During normal driving

The gasoline engine is predominantly used. The electric motor (traction motor) charges the hybrid battery (traction battery) as necessary.

■ When accelerating sharply

When the accelerator pedal is depressed heavily, the power of the hybrid battery (traction battery) is added to that of the gasoline engine via the electric motor (traction motor).

■ When braking (regenerative braking)

The wheels operate the electric motor (traction motor) as a power generator, and the hybrid battery (traction battery) is charged.

■ Regenerative braking

- In the following situations, kinetic energy is converted to electric energy and deceleration force can be obtained in conjunction with the recharging of the hybrid battery (traction battery).
 - The accelerator pedal is released while driving with the shift lever in D or B.
 - The brake pedal is depressed while driving with the shift lever in D or B.
- Vehicles with GPF system: While the GPF system (→P.276) is operating to

regenerate the exhaust gas filter, the hybrid battery (traction battery) may not be recharged.

■ EV indicator

The EV indicator comes on when the vehicle is driven using only the electric motor (traction motor) or the gasoline engine is stopped.

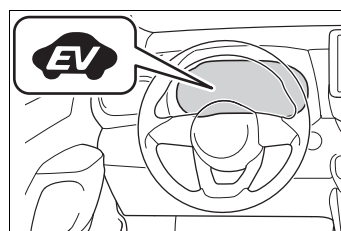

■ Conditions in which the gasoline engine may not stop

The gasoline engine starts and stops automatically. However, it may not stop automatically in the following conditions:

- During gasoline engine warm-up
- During hybrid battery (traction battery) charging
- When the temperature of the hybrid battery (traction battery) is high or low
- When the heater is switched on

Depending on the circumstances, the gasoline engine may also not stop automatically in other situations.

■ Charging the hybrid battery (traction battery)

As the gasoline engine charges the hybrid battery (traction battery), the battery does not need to be charged from an outside source. However, if the vehicle is left parked for a long time the hybrid battery (traction battery) will slowly discharge. For this reason, be sure to drive the vehicle at least once every few months for at least 30 minutes or 16 km (10 miles). If the hybrid battery (traction battery) becomes fully discharged and you are unable to start the hybrid system, contact any authorized Toyota retailer or Toyota authorized repairer, or any reliable repairer.

■ Charging the 12-volt battery

→P.411

■ After the 12-volt battery has discharged or when the terminal has been removed and installed during exchange, etc.

The gasoline engine may not stop even if the vehicle is being driven by the hybrid battery (traction battery). If this continues for a few days, contact any authorized Toyota retailer or Toyota authorized repairer, or any reliable repairer.

■ Sounds and vibrations specific to a hybrid vehicle

There may be no engine sound or vibration even though the vehicle is able to move with the "READY" indicator is illuminated. For safety, apply the parking brake and make sure to shift the shift lever to P when parked.

The following sounds or vibrations may occur when the hybrid system is operating and are not a malfunction:

- Motor sounds may be heard from the engine compartment.
- Sounds may be heard from the hybrid battery (traction battery) under the rear seats when the hybrid system starts or stops.
- Relay operating sounds such as a snap or soft clank will be emitted from the hybrid battery (traction battery), under the rear seats, when the hybrid system is started or stopped.
- Sounds from the hybrid system may be heard when the back door is open.
- Sounds may be heard from the transmission when the gasoline engine starts or stops, when driving at low speeds, or during idling.
- Engine sounds may be heard when accelerating sharply.
- Sounds may be heard due to regenerative braking when the brake pedal is depressed or as the accelerator pedal is released.

- Vibration may be felt when the gasoline engine starts or stops.

- Cooling fan sounds may be heard from the air intake vent on the side of the lower part of the rear left seat.

■ Maintenance, repair, recycling, and disposal

Contact any authorized Toyota retailer or Toyota authorized repairer, or any reliable repairer regarding maintenance, repair, recycling and disposal. Do not dispose of the vehicle yourself.

■ Customization

Some functions can be customized. (→P.431)

Acoustic vehicle alerting system

When the gasoline engine is off while driving, a sound is produced to warn pedestrians, people riding bicycles or other people and vehicles in the surrounding area that the vehicle is approaching. The pitch of the sound adjusts according to vehicle speed. When vehicle speed is approximately 25 km/h (16 mph) or more, the warning system turns off.

■ Acoustic vehicle alerting system

In the following cases, the acoustic vehicle alerting system sound may be difficult for pedestrians, people riding bicycles or other people and vehicles in the surrounding area to hear:

- When there is a lot of noise in the vicinity
- When it is raining or during strong winds
- When in the area surrounding the rear of the vehicle, rather than in front of the vehicle

Hybrid system precautions

Take care when handling the hybrid system, as it is a high voltage system (about 580V at maximum) as well as contains parts that become extremely hot when the hybrid system is operating. Obey the warning labels attached to the vehicle.

System components

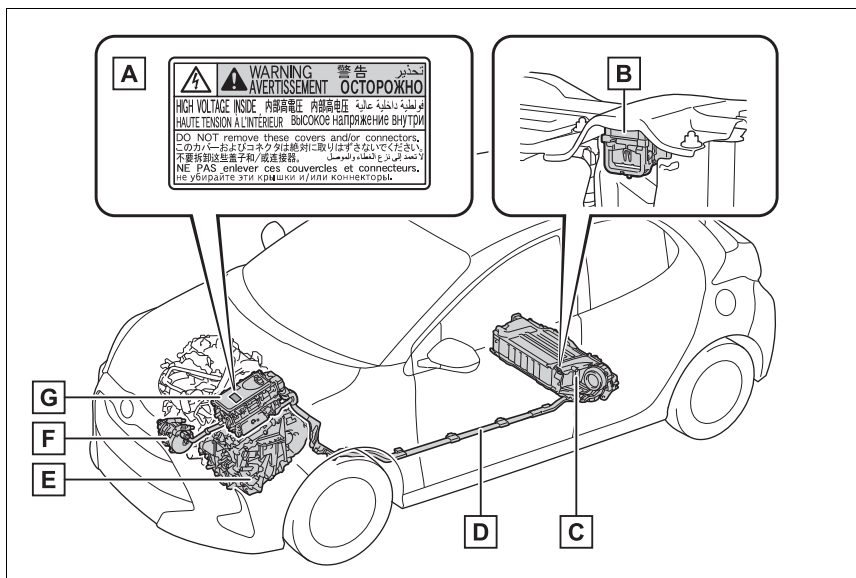

The illustration is an example for explanation and may differ from the actual item.

- A** Warning label
- B** Service plug
- C** Hybrid battery (traction battery)
- D** High voltage cables (orange)
- E** Electric motor (traction motor)
- F** Air conditioning compressor
- G** Power control unit

■ Running out of fuel

When the vehicle has run out of fuel and the hybrid system cannot be started, refuel the vehicle with at least enough gasoline to make the low fuel level warning light (→P.377) go off. If there is only a small amount of fuel, the hybrid system may not be able to start. (The standard amount of fuel is about 5.8 L [1.6 gal., 1.3 Imp. gal.] [vehicles without rear wiper] or 6.3 L [1.7 gal., 1.4 Imp. gal.] [vehicles with rear wiper] when the vehicle is on a level surface. This value may vary when the vehicle is on a slope. Add extra fuel when the vehicle is inclined.)

■ Electromagnetic waves

- High voltage parts and cables on hybrid vehicles incorporate electromagnetic shielding, and therefore emit approximately the same amount of electromagnetic waves as conventional gasoline powered vehicles or home electronic appliances.
- Your vehicle may cause sound interference in some third party-produced radio parts.

■ Hybrid battery (traction battery)

The hybrid battery (traction battery) has a limited service life. The lifespan of the hybrid battery (traction battery) can change in accordance with driving style and driving conditions.

■ Starting the hybrid system in an extremely cold environment

When the hybrid battery (traction battery) is extremely cold (below approximately -30°C [-22°F]) under the influence of the outside temperature, it may not be possible to start the hybrid system. In this case, try to start the hybrid system again after the temperature of the hybrid battery increases due to the outside temperature increase etc.

■ Declaration of conformity

This model conforms to hydrogen emissions according to regulation ECE100 (Battery electric vehicle safety).

⚠ WARNING

■ High voltage precautions

This vehicle has high voltage DC and AC systems as well as a 12-volt system. DC and AC high voltage is very dangerous and can cause severe burns and electric shock that may result in death or serious injury.

- Never touch, disassemble, remove or replace the high voltage parts, cables or their connectors.
- The hybrid system will become hot after starting as the system uses high voltage. Be careful of both the high voltage and the high temperature, and always obey the warning labels attached to the vehicle.
- Never try to open the service plug access hole located under the left side of the rear seat. The service plug is used only when the vehicle is serviced and is subject to high voltage.

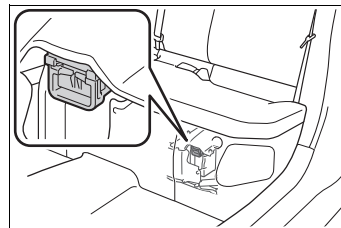

■ Road accident cautions

Observe the following precautions to reduce the risk of death or serious injury:

- Pull your vehicle off the road, apply the parking brake, shift the shift lever to P, and turn the hybrid system off.
- Do not touch the high voltage parts, cables and connectors.

**WARNING**

- If electric wires are exposed inside or outside your vehicle, an electric shock may occur. Never touch exposed electric wires.
- If a fire occurs in the hybrid vehicle, leave the vehicle as soon as possible. Never use a fire extinguisher that is not meant for electric fires. Using even a small amount of water may be dangerous.
- If your vehicle needs to be towed, do so with the front wheels raised. If the wheels connected to the electric motor (traction motor) are on the ground when towing, the motor may continue to generate electricity. This may cause a fire. (→P.369)
- Carefully inspect the ground under the vehicle. If you find that liquid has leaked onto the ground, the fuel system may have been damaged. Leave the vehicle as soon as possible.
- Do not touch the battery if liquid is leaking from or adhering to it. If electrolyte (carbonate ester-based organic electrolyte) from the hybrid battery (traction battery) comes into contact with the eyes or skin, it could cause blindness or skin wounds. In the unlikely event that it comes into contact with the eyes or skin, wash it off immediately with a large amount of water, and seek immediate medical attention.

- If electrolyte is leaking from the hybrid battery (traction battery), do not approach the vehicle. Even in the unlikely event that the hybrid battery (traction battery) is damaged, the internal construction of the battery will prevent a large amount of electrolyte from leaking out. However, any electrolyte that does leak out will give off a vapor. This vapor is an irritant to skin and eyes and could cause acute poisoning if inhaled.
- Do not bring burning or high-temperature items close to the electrolyte. The electrolyte may ignite and cause a fire.

Hybrid battery (traction battery)

- Your vehicle contains a sealed lithium-ion battery.
- Never resell, hand over or modify the hybrid battery. To prevent accidents, hybrid batteries that have been removed from a disposed vehicle are collected through any authorized Toyota retailer or Toyota authorized repairer, or any reliable repairer. Do not dispose of the battery yourself.

Unless the battery is properly collected, the following may occur, resulting in death or serious injury:

- The hybrid battery may be illegally disposed of or dumped, and it is hazardous to the environment or someone may touch a high voltage part, resulting in an electric shock.
- The hybrid battery is intended to be used exclusively with your hybrid vehicle. If the hybrid battery is used outside of your vehicle or modified in any way, accidents such as electric shock, heat generation, smoke generation, an explosion and electrolyte leakage may occur.

⚠ WARNING

When reselling or handing over your vehicle, the possibility of an accident is extremely high because the person receiving the vehicle may not be aware of these dangers.

- If your vehicle is disposed of without the hybrid battery having been removed, there is a danger of serious electric shock if high voltage parts, cables and their connectors are touched. In the event that your vehicle must be disposed of, the hybrid battery must be disposed of by any authorized Toyota retailer or Toyota authorized repairer, or any reliable repairer. If the hybrid battery is not disposed of properly, it may cause electric shock that can result in death or serious injury.

⚠ NOTICE**■ Hybrid battery (traction battery) air intake vent**

Do not carry large amounts of water such as water cooler bottles in the vehicle. If water spills onto the hybrid battery (traction battery), the battery may be damaged. Have the vehicle inspected by any authorized Toyota retailer or Toyota authorized repairer, or any reliable repairer.

Hybrid battery (traction battery) air intake vent

There is an air intake vent under the left side of the rear seat for the purpose of cooling the hybrid battery (traction battery). If the vent becomes blocked, the hybrid battery (traction battery) input and output may be reduced.

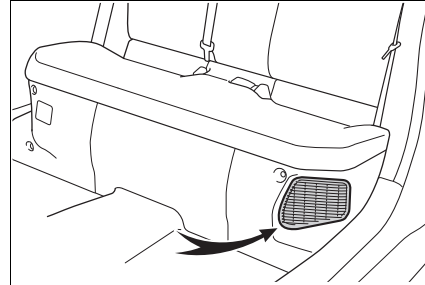
**⚠ NOTICE****■ Hybrid battery (traction battery) air intake vent**

- Make sure that the air intake vent is not blocked, such as by a seat cover, plastic cover, or luggage. If the vent is blocked, the hybrid battery (traction battery) input and output may be restricted, possibly leading to a malfunction.
- Clean the air intake vent regularly to prevent the hybrid battery (traction battery) from overheating.
- Do not get water or foreign materials in the air intake vent as this may cause a short circuit and damage the hybrid battery (traction battery).
- A filter is installed to the air intake vent. When the filter remains noticeably dirty even after cleaning the air intake vent, filter cleaning or replacement is recommended. Refer to P.348 for details on how to clean the filters.

Emergency shut off system

When a certain level of impact is detected by the impact sensor, the emergency shut off system blocks the high voltage current and stops the fuel pump to minimize the risk of electrocution and fuel leakage. If the emergency shut off system acti-

vates, your vehicle will not restart. To restart the hybrid system, contact any authorized Toyota retailer or Toyota authorized repairer, or any reliable repairer.

Hybrid warning message

A message is automatically displayed when a malfunction occurs in the hybrid system or an improper operation is attempted.

If a warning message is shown on the multi-information display, read the message and follow the instructions.

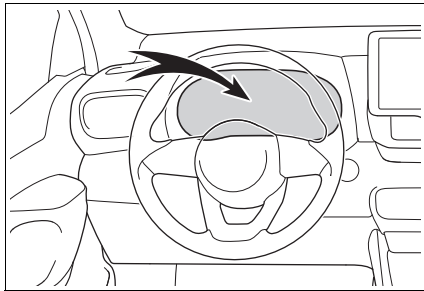

■ **If a warning light comes on, a warning message is displayed, or the 12-volt battery is disconnected**

The hybrid system may not start. In this case, try to start the system again. If the "READY" indicator does not come on, contact any authorized Toyota retailer or Toyota authorized repairer, or any reliable repairer.

Immobilizer system

The vehicle's keys have built-in transponder chips that prevent the hybrid system from starting if a key has not been previously registered in the vehicle's on-board computer. Never leave the keys inside the vehicle when you leave the vehicle.

This system is designed to help prevent vehicle theft but does not guarantee absolute security against all vehicle thefts.

Operating the system

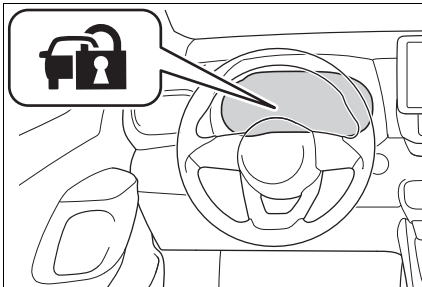

- ▶ Vehicles without a smart entry & start system

The indicator light flashes after the key has been removed from the power switch to indicate that the system is operating.

The indicator light stops flashing after the registered key has been inserted into the power switch to indicate that the system has been

canceled.

- ▶ Vehicles with a smart entry & start system

The indicator light flashes after the power switch has been turned off to indicate that the system is operating.

The indicator light stops flashing after the power switch has been turned to ACC or ON to indicate that the system has been canceled.

■ System maintenance

The vehicle has a maintenance-free type immobilizer system.

■ Conditions that may cause the system to malfunction

- If the grip portion of the key is in contact with a metallic object
- If the key is in close proximity to or touching a key to the security system (key with a built-in transponder chip) of another vehicle

■ Certifications for the immobilizer system

→P.443

⚠ NOTICE

■ To ensure the system operates correctly

Do not modify or remove the system. If modified or removed, the proper operation of the system cannot be guaranteed.

Double locking system *

*: If equipped

Unauthorized access to the vehicle is prevented by disabling the door unlocking function from both the interior and exterior of the vehicle. Vehicles employing this system have labels on the window glass of both front doors.

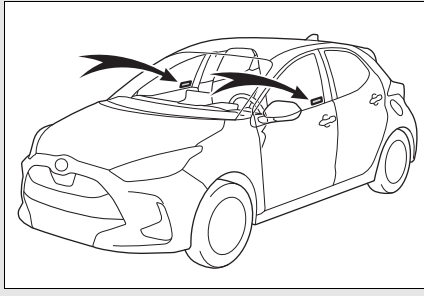

Setting/canceling the double locking system

■ Setting

Turn the power switch off, have all the passengers exit the vehicle and ensure that all the doors are closed.

Using the entry function (if equipped): Touch the sensor area on the outside door handle twice within 5 seconds.

Using the wireless remote control:

Press  twice within 5 seconds.

■ Canceling

Using the entry function (if equipped): Hold the outside door

handle.

Using the wireless remote control:

Press .

WARNING

■ Double locking system precaution

Never activate the double locking system when there are people in the vehicle because all the doors cannot be opened from inside the vehicle.

1

For safety and security

Alarm*

*: If equipped

The alarm uses light and sound to give an alert when an intrusion is detected. The alarm is triggered in the following situations when the alarm is set:

- A locked door is unlocked or opened in any way other than using the entry function (if equipped) or wireless remote control. (The doors will lock again automatically.)
- The hood is opened.

Setting/canceling/stopping the alarm system

■ Items to check before locking the vehicle

To prevent unexpected triggering of the alarm and vehicle theft, make sure of the following:

- Nobody is in the vehicle.
- The windows are closed before the alarm is set.
- No valuables or other personal items are left in the vehicle.

■ Setting

Close the door and hood, and lock all the doors using the entry function (if equipped) or wireless remote control. The system will set automatically after 30 seconds.

The indicator light changes from being on to flashing when the system is set.

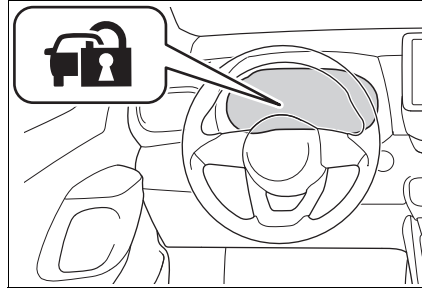

■ Canceling or stopping

Do one of the following to deactivate or stop the alarms:

- Unlock the doors using the entry function (if equipped) or wireless remote control.
- Starting the hybrid system. (The alarm will be deactivated or stopped after a few seconds.)

■ System maintenance

The vehicle has a maintenance-free type alarm system.

■ Triggering of the alarm

The alarm may be triggered in the following situations: (Stopping the alarm deactivates the alarm system.)

- The doors are unlocked using the key or the mechanical key.

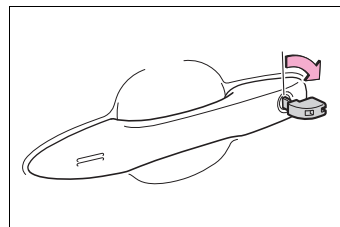

- A person inside the vehicle opens a door or hood, or unlocks the vehicle.



- The 12-volt battery is recharged or replaced when the vehicle is locked. (→P.411)

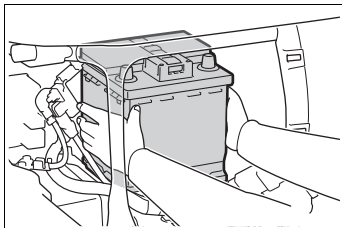

■ Alarm-operated door lock

In the following cases, depending on the situation, the door may automatically lock to prevent improper entry into the vehicle:

- When a person remaining in the vehicle unlocks the door and the alarm is activated.
- While the alarm is activated, a person remaining in the vehicle unlocks the door.
- When recharging or replacing the 12-volt battery



NOTICE

■ To ensure the system operates correctly

Do not modify or remove the system. If modified or removed, the proper operation of the system cannot be guaranteed.

Vehicle status information and indicators

2

2-1. Instrument cluster

Warning lights and indicators	90
Gauges and meters (vertical display)	94
Gauges and meters (horizontal display)	99
Multi-information display (vertical display).....	103
Multi-information display (horizontal display).....	109
Head-up display.....	116
Energy monitor/consumption screen.....	120

Warning lights and indicators

The warning lights and indicators on the instrument cluster, center panel and outside rear view mirrors inform the driver of the status of the vehicle's various systems.

Warning lights and indicators displayed on the instrument cluster

For the purpose of explanation, the following illustrations display all warning lights and indicators illuminated.

► Vertical display

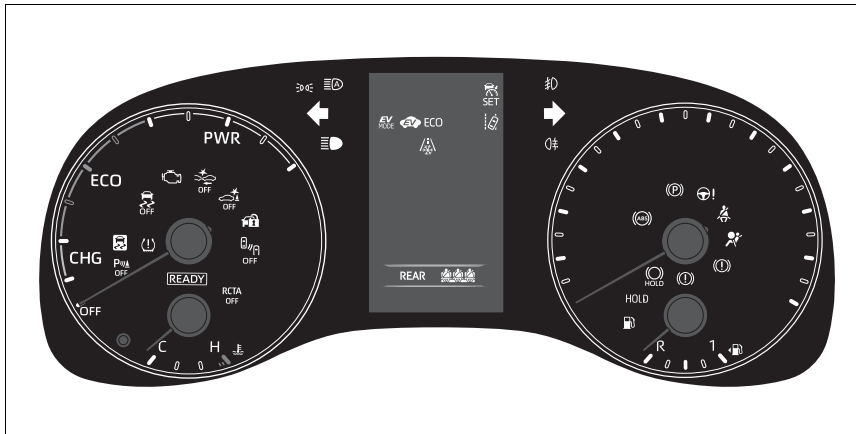

The units of measure may differ depending on the intended destination of the vehicle.









► Horizontal display



















The units of measure may differ depending on the intended destination of the vehicle.

Warning lights

Warning lights inform the driver of malfunctions in the indicated vehicle's systems.

-  Brake system warning light*¹
(Red) (→P.374)
-  Brake system warning light*¹
(Yellow) (→P.374)
-  High coolant temperature warning light*² (→P.374)
-  Hybrid system overheat warning light*² (→P.375)
-  Charging system warning light*² (→P.375)
-  Low engine oil pressure warning light*² (→P.375)
-  Malfunction indicator lamp*¹
(→P.375)
-  SRS warning light*¹
(→P.376)

-  ABS warning light*¹
(→P.376)
-  Inappropriate pedal operation warning light*² (→P.376)
-  Electric power steering system warning light*¹ (Red)
(→P.377)
-  Electric power steering system warning light*¹ (Yellow)
(→P.377)
-  Low fuel level warning light
(→P.377)
-  Driver's and front passenger's seat belt reminder light
(→P.377)
-  Rear passengers' seat belt reminder lights*²
(→P.377)
-  Tire pressure warning light*¹
(→P.378)
-  LTA indicator*² (if equipped)
(Orange) (→P.378)

	Toyota parking assist-sensor OFF indicator* ¹ (if equipped) (Flashes) (→P.379)
	“RCTA OFF” indicator* ¹ (if equipped) (→P.379) (Flashes)
	PKSB OFF indicator* ¹ (if equipped) (→P.379)
	PCS warning light* ¹ (if equipped) (→P.380) (Flashes or illuminates)
	Slip indicator* ¹ (→P.380)
	Parking brake indicator (Flashes) (→P.380)
	Brake hold operated indicator* ¹ (→P.381) (Flashes)

*¹: These lights come on when the power switch is turned to ON to indicate that a system check is being performed. They will turn off after the hybrid system is started, or after a few seconds. There may be a malfunction in a system if the lights do not come on, or turn off. Have the vehicle inspected by any authorized Toyota retailer or Toyota authorized repairer, or any reliable repairer.

*²: This light illuminates on the multi-information display.











WARNING

■ If a safety system warning light does not come on

Should a safety system light such as the ABS and SRS warning light not come on when you start the hybrid system, this could mean that these systems are not available to help protect you in an accident, which could result in death or serious injury. Have the vehicle inspected by any authorized Toyota retailer or Toyota authorized repairer, or any reliable repairer immediately if this occurs.

Indicators

The indicators inform the driver of the operating state of the vehicle's various systems.

	Turn signal indicator (→P.184)
	Tail light indicator (→P.190)
	Headlight high beam indicator (→P.192)
	Automatic High Beam indicator (if equipped) (→P.193)
	Front fog light indicator (if equipped) (→P.196)
	Rear fog light indicator (→P.196)
	PCS warning light* ^{1, 2} (if equipped) (→P.212)
	Cruise control indicator* ³ (if equipped) (→P.230)
	Dynamic radar cruise control indicator* ³ (if equipped) (→P.230)
	Cruise control “SET” indicator* ³ (if equipped) (→P.230)

 LTA indicator^{*3} (if equipped)
(→P.209, 225)

 BSM outside rear view mirror
indicators^{*1, 5} (if equipped)
(→P.249, 260)

 BSM OFF indicator^{*2} (if
equipped) (→P.249)

 Toyota parking assist-sensor
OFF indicator^{*1, 2} (if
equipped) (→P.254)

 "RCTA OFF" indicator^{*1, 2} (if
equipped) (→P.260)

 PKSB OFF indicator^{*1, 2} (if
equipped) (→P.266)

 Speed limiter indicator^{*3} (if
equipped) (→P.242)

 Slip indicator^{*1} (→P.278)
(Flashes)

 VSC OFF indicator^{*1, 2}
(→P.278)

 Smart entry & start system
indicator^{*3} (→P.175)

 "READY" indicator (→P.175)

 EV drive mode indicator^{*6}
(→P.179)

 Parking brake indicator
(→P.184)

 Brake hold standby indica-
tor^{*1} (→P.187)

 Brake hold operated indica-
tor^{*1} (→P.187)

 EV indicator^{*6} (→P.77)

 Low outside temperature
indicator^{*3, 7} (→P.94, 99)

 Security indicator (→P.84,
86)

 "PASSENGER AIR
BAG" indicator^{*1, 8}
(→P.45)

 Eco drive mode indicator^{*3}
(→P.275)

 Power mode indicator^{*3}
(→P.275)

^{*1}: These lights come on when the power switch is turned to ON to indicate that a system check is being performed. They will turn off after the hybrid system is started, or after a few seconds. There may be a malfunction in a system if the lights do not come on, or turn off. Have the vehicle inspected by any authorized Toyota retailer or Toyota authorized repairer, or any reliable repairer.

^{*2}: This light comes on when the system is turned off.

^{*3}: This light illuminates on the multi-information display.

^{*4}: Depending on the operating condition, the color and illuminating/flash- ing state of the light change.

^{*5}: This light illuminates on the outside rear view mirrors.

^{*6}: For vehicles with vertical display, this light illuminates on the multi-informa- tion display.

^{*7}: When the outside temperature is approximately 3°C (37°F) or lower, this indicator will flash for approxi- mately 10 seconds, then stay on.

^{*8}: This light illuminates on the center panel.

Gauges and meters (vertical display)

Meter display

■ **Locations of gauges and meters**

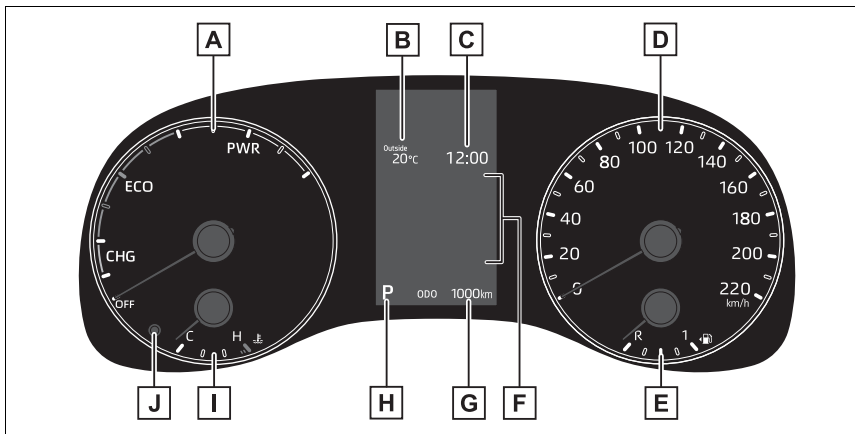

The units of measure may differ depending on the intended destination of the vehicle.

A Hybrid System Indicator (→P.95)

Displays hybrid system output or regeneration level

B Outside temperature

Displays the outside temperature within the range of -40°C (-40°F) to 60°C (140°F)

C Clock (→P.97)

D Speedometer

E Fuel gauge

Displays the fuel level. In the following situations, the actual fuel level may not be displayed correctly:

- After refueling only a small amount (approximately 5 L or less)
- When stopped on a hill or other slope
- When driving on a slope or around a curve

F Multi-information display

Presents the driver with a variety of vehicle data (→P.103)

Displays warning messages if a malfunction occurs (→P.383)

G Odometer and trip meter display (→P.96)

H Shift position indicator (→P.181)

I Engine coolant temperature gauge

Displays the engine coolant temperature

J Display change button (→P.96)

■ Engine speed

On hybrid vehicles, engine speed is precisely controlled in order to help improve fuel efficiency and reduce exhaust emissions, etc.

There are times when the engine speed that is displayed may differ even when vehicle operation and driving conditions are the same.

■ Hybrid System Indicator

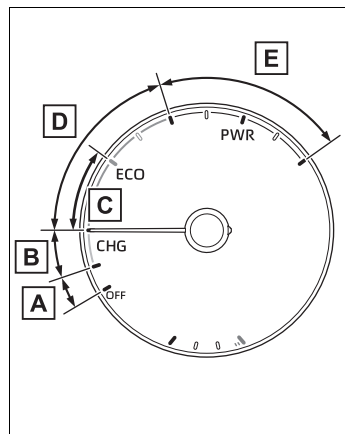

A READY OFF area

Shows that the hybrid system is not operating.

B Charge area

Shows regeneration* status.

Regenerated energy will be used to charge the hybrid battery (traction battery).

C Hybrid Eco area

Shows that gasoline engine power is not being used very often.

The gasoline engine will automatically stop and restart under various conditions.

D Eco area

Shows that the vehicle is being driven in an Eco-friendly manner.

By keeping the indicator needle within Eco area, more Eco-friendly driving can be achieved.

E Power area

Shows that an Eco-friendly driving range is being exceeded (during full power driving, etc.)

*: When used in this manual, "regeneration" refers to the conversion of energy created by the movement of the vehicle into electrical energy.

In the following situation, the Hybrid System Indicator does not operate.

- "READY" indicator is not illuminated.
- The shift position is in a range other than D or B.

■ Outside temperature display

- In the following situations, the correct outside temperature may not be displayed, or the display may take longer than normal to change:
 - When stopped, or driving at low speeds (less than 25 km/h [16 mph])
 - When the outside temperature has changed suddenly (at the entrance/exit of a garage, tunnel, etc.)
- When "--" is displayed, the system

may be malfunctioning. Take your vehicle to any authorized Toyota retailer or Toyota authorized repairer, or any reliable repairer.

■ Fuel gauge and driving range display

The fuel gauge and driving range display are linked. If the fuel gauge and driving range display do not update after refueling a small amount, they can be updated by performing the following procedure:

- 1 Stop the vehicle on a level surface. Wait until the fuel in the fuel tank stabilizes.
- 2 Press the display change button to change the odometer and trip meter display to the odometer.
- 3 Turn the power switch off.
- 4 While pressing and holding the display change button, turn the power switch to ON.
- 5 Continue holding the display change button for approximately 5 seconds.

Release the button when the odometer begins blinking.

Updating will be complete when the odometer blinks for approximately 5 seconds and then returns to the normal display.

■ Liquid crystal display

→P.104

■ Customization

The gauges and meters can be customized in  of the multi-information display. (→P.431)

WARNING

■ The information display at low temperatures

Allow the interior of the vehicle to warm up before using the liquid crystal information display. At extremely low temperatures, the information display monitor may respond slowly, and display changes may be delayed.

For example, there is a lag between the driver's shifting and the new gear number appearing on the display. This lag could cause the driver to downshift again, causing rapid and excessive engine braking and possibly an accident resulting in death or injury.

NOTICE

■ To prevent damage to the engine and its components

The engine may be overheating if the engine coolant temperature gauge is in the red zone (H). In this case, immediately stop the vehicle in a safe place, and check the engine after it has cooled completely. (→P.414)

Odometer and trip meter display

■ Changing the display

Press the display change button until the desired item is displayed.

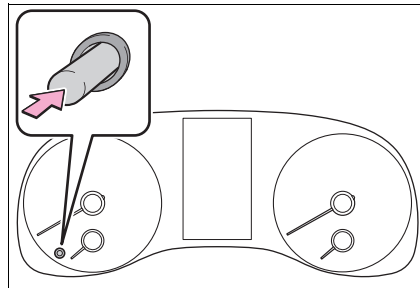

■ Display items

● Odometer

Displays the total distance the vehicle has been driven.

● Trip meter A/Trip meter B

Displays the distance the vehicle has been driven since the meter was last reset. Trip meters A and B can be used to record and display different distances independently.

To reset, display the desired trip meter and press and hold the display change button.

● Distance until next engine oil change

Displays the distance the vehicle can be driven until an oil change is necessary.

The distance until the next engine oil change will also be displayed in the following situations:

- When the power switch is turned to ON.
- When a warning message indicating that oil maintenance should be performed soon or is required is displayed.
- Resetting: →P.327

Adjusting the clock (vehicles without 7-inch/8-inch display multimedia system)

■ Adjusting the minute to “00”

- 1 Press or to select of the multi-information display.
- 2 Press or to select “Clock : 00”.

Press the OK to set the clock to the beginning of the nearest hour.

e.g.

1:00 to 1:29 → 1:00

1:30 to 1:59 → 2:00

■ Changing the clock

- 1 Press or to select of the multi-information display.
- 2 Press or to select “Clock : 00”.
- 3 Press and hold the OK .
- 4 Press or to select an item to be changed.
- 5 Press or to change the setting.

The following can be changed:

- 12-hour/24-hour format
- Hour
- Minute

Adjusting the clock (vehicles with 7-inch/8-inch display multimedia system)

The clocks on the following can be adjusted on the multimedia system screen.

- Multi-information display
- Multimedia system screen

For details, refer to “Navigation and multimedia system Owner’s man-

ual”.









■ **Clock settings screen (vehicles with 7-inch/8-inch display multimedia system)**

If “Clock : 00” is displayed when  is selected on the multi-information display, the system may be malfunctioning. Have the vehicle inspected by any authorized Toyota retailer or Toyota authorized repairer, or any reliable repairer.

Adjusting the instrument panel light control

The brightness of the instrument panel lights can be adjusted on select  to the multi-information display.

The brightness of the instrument panel lights can be adjusted separately for when the tail lights are on and off.

- 1 Press  or  to select  of the multi-information display.
- 2 Press  or  to select , and then press and hold the OK.
- 3 Press  or  to change the brightness.

Gauges and meters (horizontal display)

Meter display

■ Locations of gauges and meters

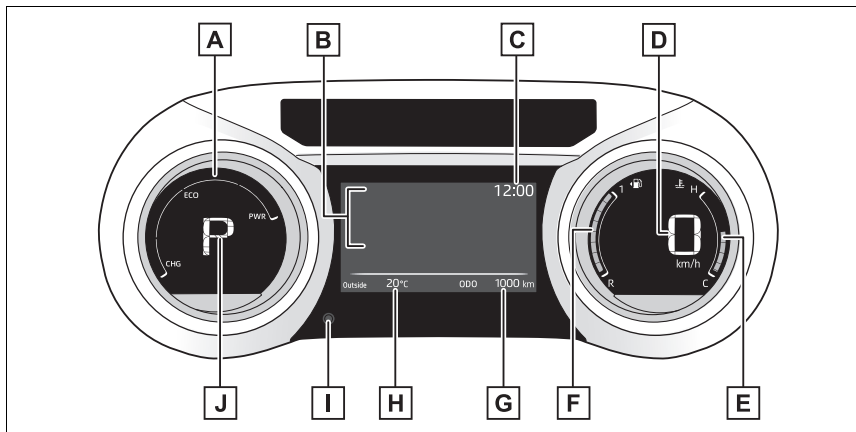

The units of measure may differ depending on the intended destination of the vehicle.

A Hybrid System Indicator (→P.100)

Displays hybrid system output or regeneration level

B Multi-information display

Presents the driver with a variety of vehicle data (→P.109)

Displays warning messages if a malfunction occurs (→P.383)

C Clock (→P.102)

D Speedometer

E Engine coolant temperature gauge

Displays the engine coolant temperature

F Fuel gauge

Displays the fuel level. In the following situations, the actual fuel level may not be displayed correctly:

- After refueling only a small amount (approximately 5 L or less)
- When stopped on a hill or other slope
- When driving on a slope or around a curve

G Odometer and trip meter display (→P.101)

H Outside temperature

Displays the outside temperature within the range of -40°C (-40°F) to 60°C (140°F)

I Display change button (→P.101)

J Shift position indicator (→P.181)

■ **Engine speed**

On hybrid vehicles, engine speed is precisely controlled in order to help improve fuel efficiency and reduce exhaust emissions, etc.

There are times when the engine speed that is displayed may differ even when vehicle operation and driving conditions are the same.

■ **Hybrid System Indicator**

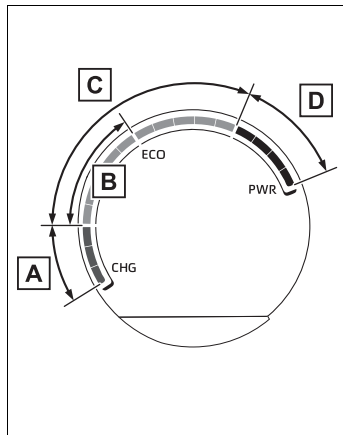

A Charge area

Shows regeneration* status.

Regenerated energy will be used to charge the hybrid battery (traction battery).

B Hybrid Eco area

Shows that gasoline engine power is not being used very often.

The gasoline engine will automatically stop and restart under various condi-

tions.

C Eco area

Shows that the vehicle is being driven in an Eco-friendly manner.

By keeping the indicator needle within Eco area, more Eco-friendly driving can be achieved.

D Power area

Shows that an Eco-friendly driving range is being exceeded (during full power driving, etc.)

*: When used in this manual, “regeneration” refers to the conversion of energy created by the movement of the vehicle into electrical energy.

In the following situation, the Hybrid System Indicator does not operate.

- Hybrid System Indicator is not illuminated.
- The shift position is in a range other than D or B.

■ **Outside temperature display**

● In the following situations, the correct outside temperature may not be displayed, or the display may take longer than normal to change:

- When stopped, or driving at low speeds (less than 25 km/h [16 mph])
- When the outside temperature has changed suddenly (at the entrance/exit of a garage, tunnel, etc.)

● When “-” is displayed, the system may be malfunctioning. Take your vehicle to any authorized Toyota retailer or Toyota authorized repairer, or any reliable repairer.

■ Fuel gauge and driving range display

The fuel gauge and driving range display are linked. If the fuel gauge and driving range display do not update after refueling a small amount, they can be updated by performing the following procedure:

- 1 Stop the vehicle on a level surface. Wait until the fuel in the fuel tank stabilizes.
- 2 Press the display change button to change the odometer and trip meter display to the odometer.
- 3 Turn the power switch off.
- 4 While pressing and holding the display change button, turn the power switch to ON.
- 5 Continue holding the display change button for approximately 5 seconds.

Release the button when the odometer begins blinking.

Updating will be complete when the odometer blinks for approximately 5 seconds and then returns to the normal display.

■ Liquid crystal display

→P.110

■ Customization

The gauges and meters can be customized in  of the multi-information display. (→P.431)

⚠ WARNING

■ The information display at low temperatures

Allow the interior of the vehicle to warm up before using the liquid crystal information display. At extremely low temperatures, the information display monitor may respond slowly, and display changes may be delayed.

For example, there is a lag between the driver's shifting and the new gear number appearing on the display. This lag could cause the driver to downshift again, causing rapid and excessive engine braking and possibly an accident resulting in death or injury.

⚠ NOTICE

■ To prevent damage to the engine and its components

The engine may be overheating if the engine coolant temperature gauge is in the red zone (H). In this case, immediately stop the vehicle in a safe place, and check the engine after it has cooled completely. (→P.414)

Odometer and trip meter display

■ Changing the display

Press the display change button until the desired item is displayed.

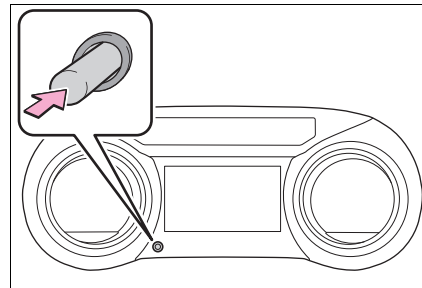

■ Display items

● Odometer

Displays the total distance the vehicle has been driven.

● Trip meter A/Trip meter B

Displays the distance the vehicle has been driven since the meter was last

reset. Trip meters A and B can be used to record and display different distances independently.

To reset, display the desired trip meter and press and hold the display change button.

- Distance until next engine oil change

Displays the distance the vehicle can be driven until an oil change is necessary.

The distance until the next engine oil change will also be displayed in the following situations:

- When the power switch is turned to ON.
- When a warning message indicating that oil maintenance should be performed soon or is required is displayed.
- Resetting: →P.327

Adjusting the clock (vehicles without 7-inch/8-inch display multimedia system)

■ Adjusting the minute to “00”

1 Press or to select of the multi-information display.

2 Press or to select .

Press the OK to set the clock to the beginning of the nearest hour.

e.g.

1:00 to 1:29 → 1:00

1:30 to 1:59 → 2:00

■ Changing the clock

1 Press or to select of the multi-information display.

2 Press or to select .

3 Press and hold the OK.

4 Press or to select an item to be changed.

5 Press or to change the setting.

The following can be changed:

- 12-hour/24-hour format
- Hour
- Minute

Adjusting the clock (vehicles with 7-inch/8-inch display multimedia system)

The clocks on the following can be adjusted on the multimedia system screen.

- Multi-information display
- Multimedia system screen

For details, refer to “Navigation and multimedia system Owner’s manual”.

■ Clock settings screen (vehicles with 7-inch/8-inch display multimedia system)









If is displayed when is selected on the multi-information dis-

play, the system may be malfunctioning. Have the vehicle inspected by any authorized Toyota retailer or Toyota authorized repairer, or any reliable repairer.

Adjusting the instrument panel light control

The brightness of the instrument panel lights can be adjusted on select  to the multi-information display.

The brightness of the instrument panel lights can be adjusted separately for when the tail lights are on and off.

- 1 Press  or  to select  of the multi-information display.
- 2 Press  or  to select , and then press and hold the OK.
- 3 Press  or  to change the brightness.

Multi-information display (vertical display)

Display and menu icons

■ Display

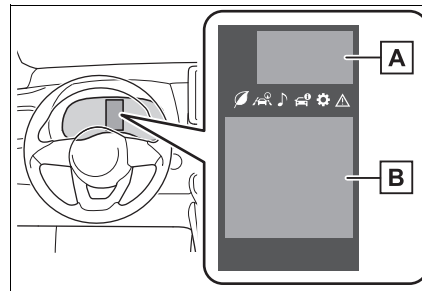

A Driving support system status display area

Displays an image when the following systems are operating and a menu icon

other than  is selected:



- LTA (Lane Tracing Assist) (if equipped) (→P.220)
- Dynamic radar cruise control with full-speed range (if equipped) (→P.230)
- RSA (Road Sign Assist) (if equipped) (→P.244)

B Content display area

By selecting menu icons on the multi-information display, a variety of driving-related information can be displayed. The multi-information display can also be used to change display settings and other vehicle settings.

Warning or advice pop-up displays are also displayed in certain situations.







■ Menu icons

The menu icons will be displayed by pressing the  or  meter

2

Vehicle status information and indicators

control switch.

-  Driving information display (→P.104)
-  Driving support system information display (if equipped) (→P.107)
-  Audio system-linked display (if equipped) (→P.107)
-  Vehicle information display (→P.107)
-  Settings display (→P.108)
-  Warning message display (→P.383)

Liquid crystal display

Small spots or light spots may appear on the display. This phenomenon is characteristic of liquid crystal displays, and there is no problem continuing to use the display.

WARNING

- **Caution for use while driving**
 - When operating the multi-information display while driving, pay extra attention to the safety of the area around the vehicle.
 - Do not look continuously at the multi-information display while driving as you may fail to see pedestrians, objects on the road, etc., ahead of the vehicle.
- **The information display at low temperatures**
→P.96

Changing the meter display

The multi-information display is operated using the meter control switches.

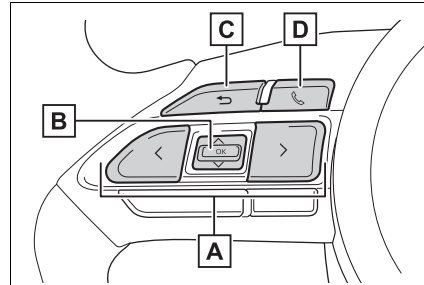

A < / > : Select menu icons

^ / v : Change displayed content, scroll up/down the screen and move the cursor up/down

B Press: Enter/Set

Press and hold: Reset/Display customizable items

C Return to the previous screen

D Call sending/receiving and history display

Linked with the hands-free system, sending or receiving call is displayed. For details regarding the hands-free system, refer to the "Navigation and multimedia system Owner's manual".

Content of driving information

Display items

- Speedometer display/Driving range
- Fuel economy
- ECO Accelerator Guidance/Eco score

■ **Speedometer display/Driving range**

- Speedometer display
- Driving range

Displays driving range with remaining fuel. Use the displayed values as a reference only.

This distance is computed based on your average fuel consumption. As a result, the actual distance that can be driven may differ from that displayed.

When only a small amount of fuel is added to the tank, the display may not be updated.

When refueling, turn the power switch off. If the vehicle is refueled without turning the power switch off, the display may not be updated.

■ **Fuel economy**

Use the displayed values as a reference only.

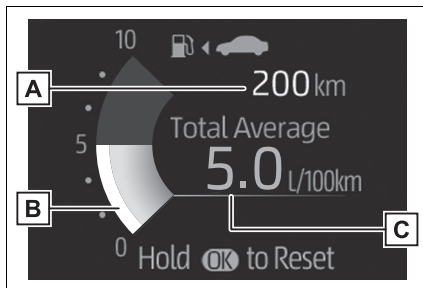

A Driving range

Displays driving range with remaining fuel.

This distance is computed based on your average fuel consumption. As a result, the actual distance that can be driven may differ from that displayed.

When only a small amount of fuel is added to the tank, the display may not

be updated.

When refueling, turn the power switch off. If the vehicle is refueled without turning the power switch off, the display may not be updated.

B Current fuel consumption

Displays instantaneous current fuel consumption.

C Average fuel economy (after reset)

To reset the average fuel economy display, press and hold the OK meter control switch.

The average fuel economy display can be changed in . (→P.108)

- Average fuel economy (after start)

Displays the average fuel consumption since hybrid system start.

- Average fuel economy (after refuel)

Displays the average fuel consumption since the vehicle was refueled.

■ **ECO Accelerator Guidance/Eco score**

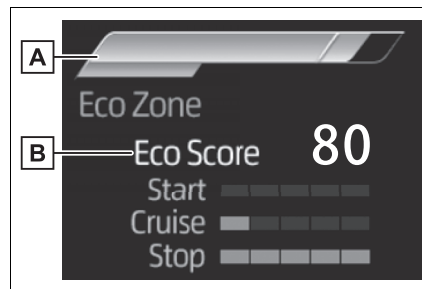

A ECO Accelerator Guidance

2

Vehicle status information and indicators

B Eco score

- ECO Accelerator Guidance

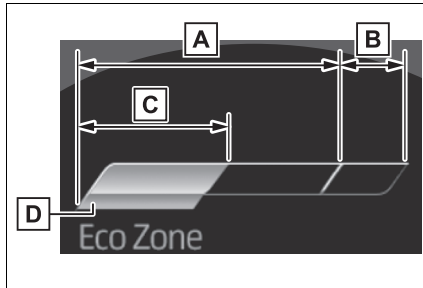

A Eco area

Shows that the vehicle is being driven in an Eco-friendly manner.

B Power area

Shows that an Eco-friendly driving range is being exceeded (during full power driving, etc.).

C Current acceleration

D Reference operation range

A zone is displayed in blue under the Eco area which can be used as a reference operation range for using the accelerator pedal according to driving conditions such as starting off and cruising.

The ECO Accelerator Guidance display changes according to the driving status, such as when starting off or cruising.

It is easier to drive in an Eco-friendly manner by driving according to the display showing the accelerator pedal operations and staying within the reference operation range.

- Eco score

The following 3 Eco driving methods are evaluated in 5 levels: Smooth start-off acceleration, driving without sudden

acceleration, and smooth stopping. When the vehicle is stopped, an Eco score out of 100 points will be displayed.

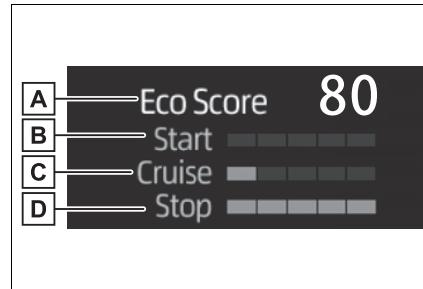

A Score result

B Eco start status

C Eco cruise status

D Eco stop status

- How to read the bar display

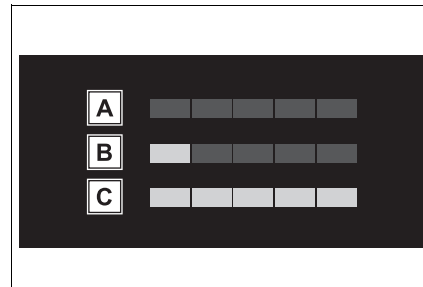

A Not yet evaluated

B Low

C High

- After the hybrid system is started, the Eco score will not be displayed until the vehicle speed exceeds approximately 20 km/h (12 mph).
- The Eco score will be reset each time the hybrid system is started.
- When the hybrid system is stopped,

the total score of the current trip will be displayed.

■ The ECO Accelerator Guidance/Eco score will not operate when

The ECO Accelerator Guidance/Eco score will not operate in the following situations:

- The Hybrid System Indicator is not operating.
- The vehicle is being driven using the dynamic radar cruise control with full-speed range. (if equipped)

Driving support system information display

■ Driving support system information

Select to display the operational status of the following systems:

- LTA (Lane Tracing Assist) (if equipped) (→P.220)
- Dynamic radar cruise control with full-speed range (if equipped) (→P.230)

■ Navigation system-linked display (if equipped)

Select to display the following navigation system-linked information:

- Route guidance to destination (if equipped)
- Compass display (heading-up display)

■ Route guidance to destination display

When the route guidance to destination display is enabled on the head-up display, it will not be displayed on the multi-information display. (→P.116)

Audio system-linked display (if equipped)

Select to enable selection of an audio source or track on the meter using the meter control switches.

This menu icon can be set to be displayed/not displayed in .

Vehicle information display

■ Display items

- Drive information
- Energy monitor (→P.120)

■ Drive information

2 items that are selected using the “Drive Info Items” setting (average speed, distance and total time) can be displayed vertically.

The displayed information changes according to the “Drive Info Type” setting (since the system was started or between resets). (→P.108)

Use the displayed information as a reference only.

Following items will be displayed.

- “Trip”
- “Average Speed”: Displays the average vehicle speed since hybrid system start*
- “Distance”: Displays the distance driven since hybrid system start*
- “Total Time”: Displays the elapsed time since hybrid system start*

*: These items are reset each time the hybrid system stops.

- “Total”
- “Average Speed”: Displays the average vehicle speed since the display was reset*
- “Distance”: Displays the distance driven since the display was reset*
- “Total Time”: Displays the elapsed time since the display was reset*

*: To reset, display the desired item and press and hold the OK meter control switch.

Settings display

■ Meter display settings that can be changed

- Clock setting (vehicles without 7-inch/8-inch display multimedia system)

→P.97

- Language

Select to change the language displayed.

- Units

Select to change the units of measure displayed.

- EV indicator

Select to enable/disable the EV indicator.



Select to change the displayed content of the following:

- Hybrid System Indicator

Select to display/not display the Eco Accelerator Guidance. (→P.105)

- Fuel economy display

Select to change the average fuel consumption display between after start/after reset/after refuel. (→P.105)

-  (if equipped)

Select to display/not display the audio system linked display.



Select to change the displayed content of the following:

- Display contents

Select to display/not display the energy monitor. (→P.120)

- Drive information type

Select to change the drive information type display between after start/after reset.

- Drive information items

Select to set the first and second items of the drive information display to any of the following: average vehicle speed/distance/elapsed time.

- Current trip result display

Select to change the displayed information about the current trip, measured from when the hybrid system was started until it was stopped, between drive information/eco score. (The information will be displayed temporarily when the hybrid system is stopped.)

- Pop-up display

Select to enable/disable pop-up displays for each relevant system.

- Multi-information display off

Select to turn the multi-information display off.

To turn the multi-information display on again, press any of the following meter control switches

▲/▼/◀/▶/OK/↵.

- Default setting

Select to reset the meter display settings to the default setting.

- **Vehicle functions and settings that can be changed**

→P.431

- **Suspension of the settings display**

- Some settings cannot be changed while driving. When changing settings, park the vehicle in a safe place.
- If a warning message is displayed, operation of the settings display will be suspended.



WARNING

- **Cautions during setting up the display**

If the hybrid system is operating while changing certain settings on the settings display, ensure that the vehicle is parked in a place with adequate ventilation. In a closed area such as a garage, exhaust gases including harmful carbon monoxide (CO) may collect and enter the vehicle. This may lead to death or a serious health hazard.



NOTICE

- **During setting up the display**

To prevent 12-volt battery discharge, ensure that the hybrid system is operating while setting up the display features.

Multi-information display (horizontal display)

Display and menu icons

- **Display**

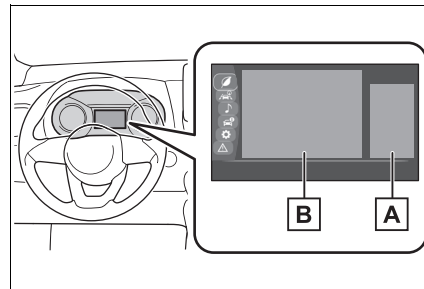

- **A Driving support system status display area**

Displays an image when the following systems are operating and a menu icon

other than  is selected:

- LTA (Lane Tracing Assist) (if equipped) (→P.220)
- Dynamic radar cruise control with full-speed range (if equipped) (→P.230)
- RSA (Road Sign Assist) (if equipped) (→P.244)

- **B Content display area**

By selecting menu icons on the multi-information display, a variety of driving-related information can be displayed.

The multi-information display can also be used to change display settings and other vehicle settings.

Warning or advice pop-up displays are also displayed in certain situations.







- **Menu icons**

The menu icons will be displayed by pressing the ▲ or ▼ meter

2

Vehicle status information and indicators

control switch.

-  Driving information display (→P.110)
-  Driving support system information display (if equipped) (→P.112)
-  Audio system-linked display (if equipped) (→P.113)
-  Vehicle information display (→P.113)
-  Settings display (→P.113)
-  Warning message display (→P.383)

■ **Liquid crystal display**

Small spots or light spots may appear on the display. This phenomenon is characteristic of liquid crystal displays, and there is no problem continuing to use the display.



 **WARNING**

- **Caution for use while driving**
 - When operating the multi-information display while driving, pay extra attention to the safety of the area around the vehicle.
 - Do not look continuously at the multi-information display while driving as you may fail to see pedestrians, objects on the road, etc., ahead of the vehicle.
- **The information display at low temperatures**
→P.101

Changing the meter display

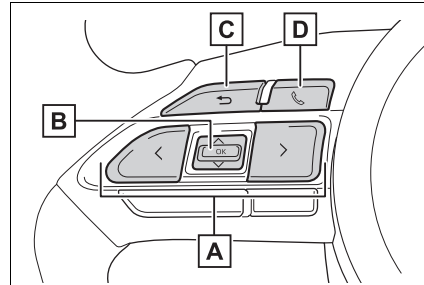
The multi-information display is operated using the meter control switches.



- A** : Select menu icons, scroll the screen and move the cursor
: Change displayed content, scroll the screen and move the cursor
- B** Press: Enter/Set
 Press and hold: Reset/Display customizable items
- C** Return to the previous screen
- D** Call sending/receiving and history display

Linked with the hands-free system, sending or receiving call is displayed. For details regarding the hands-free system, refer to the “Navigation and multimedia system Owner’s manual”.

Content of driving information

- **Display items**
 - Fuel economy
 - ECO Accelerator Guidance/Eco score
- **Fuel economy**
 Use the displayed values as a ref-

erence only.

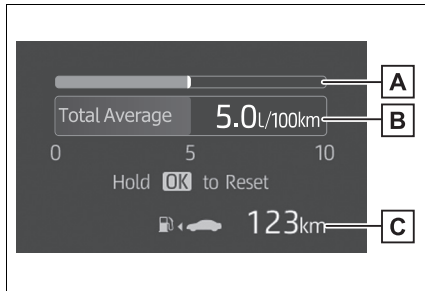

A Current fuel consumption

Displays instantaneous current fuel consumption.

B Average fuel economy (after reset)

To reset the average fuel economy display, press and hold the OK meter control switch.

C Driving range

Displays driving range with remaining fuel.

This distance is computed based on your average fuel consumption. As a result, the actual distance that can be driven may differ from that displayed. When only a small amount of fuel is added to the tank, the display may not be updated.

When refueling, turn the power switch off. If the vehicle is refueled without turning the power switch off, the display may not be updated.

The average fuel economy display can be changed in . (→P.113)

● Average fuel economy (after start)

Displays the average fuel consumption

since hybrid system start.

● Average fuel economy (after refuel)

Displays the average fuel consumption since the vehicle was refueled.

■ **ECO Accelerator Guidance/Eco score**

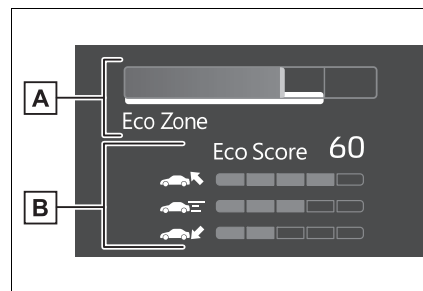

A ECO Accelerator Guidance

B Eco score

● ECO Accelerator Guidance

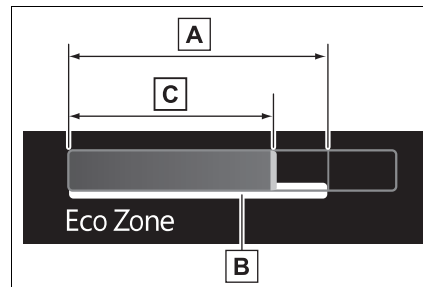

A Eco area

Indicates that the vehicle is being driven in an Eco-friendly manner.

B Zone of Eco acceleration

Displayed as a white bar, and represents an estimated suitable accelerator pedal operation range for the current driving conditions, such as starting off or cruising.

2

Vehicle status information and indicators

This display changes according to situation, such as when starting off or cruising.

C Current accelerator pedal operation

Displayed as a green bar when within the Eco area.

Eco-friendly acceleration can be achieved by keeping the accelerator pedal operation display within the range indicated by the white bar. (→P.161)

● Eco score

The following 3 Eco driving methods are evaluated in 5 levels: Smooth start-off acceleration, driving without sudden acceleration, and smooth stopping. When the vehicle is stopped, an Eco score out of 100 points will be displayed.

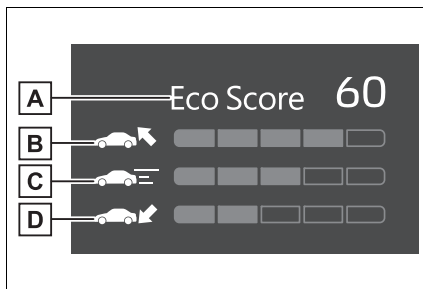

A Score result

B Eco start status

C Eco cruise status

D Eco stop status

● How to read the bar display

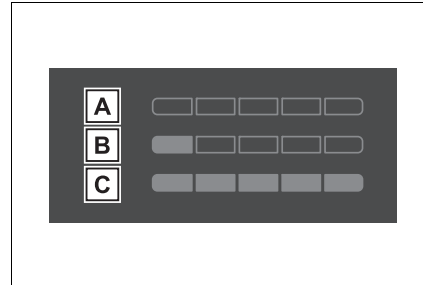

A Not yet evaluated

B Low

C High

- After the hybrid system is started, the Eco score will not be displayed until the vehicle speed exceeds approximately 20 km/h (12 mph).
- The Eco score will be reset each time the hybrid system is started.
- When the hybrid system is stopped, the total score of the current trip will be displayed.

■ **The ECO Accelerator Guidance/Eco score will not operate when**

The ECO Accelerator Guidance/Eco score will not operate in the following situations:

- The Hybrid System Indicator is not operating.
- The vehicle is being driven using the dynamic radar cruise control with full-speed range. (if equipped)

Driving support system information display

■ **Driving support system information**

Select to display the operational status of the following systems:

- LTA (Lane Tracing Assist) (if

equipped) (→P.220)

- Dynamic radar cruise control with full-speed range (if equipped) (→P.230)

■ Navigation system-linked display (if equipped)

Select to display the following navigation system-linked information:

- Route guidance to destination (if equipped)
- Compass display (heading-up display)

■ Route guidance to destination display

When the route guidance to destination display is enabled on the head-up display, it will not be displayed on the multi-information display. (→P.116)

Audio system-linked display (if equipped)

Select to enable selection of an audio source or track on the meter using the meter control switches.

This menu icon can be set to be displayed/not displayed in .

Vehicle information display

■ Display items

- Drive information
- Energy monitor (→P.120)

■ Drive information

2 items that are selected using the “Drive Info Items” setting (average speed, distance and total time) can

be displayed vertically.

The displayed information changes according to the “Drive Info Type” setting (since the system was started or between resets). (→P.113)

Use the displayed information as a reference only.

Following items will be displayed.

- “Trip”
 - “Average Speed”: Displays the average vehicle speed since hybrid system start*
 - “Distance”: Displays the distance driven since hybrid system start*
 - “Total Time”: Displays the elapsed time since hybrid system start*
- *: These items are reset each time the hybrid system stops.
- “Total”
 - “Average Speed”: Displays the average vehicle speed since the display was reset*
 - “Distance”: Displays the distance driven since the display was reset*
 - “Total Time”: Displays the elapsed time since the display was reset*

*: To reset, display the desired item and press and hold the OK meter control switch.

Settings display

■ Meter display settings that can be changed

- Clock setting (vehicles without 7-inch/8-inch display multimedia

system)

→P.102

- Language

Select to change the language displayed.

- Units

Select to change the units of measure displayed.

- EV indicator

Select to enable/disable the EV indicator.



Select to change the displayed content of the following:

- Hybrid System Indicator

Select to display/not display the Eco Accelerator Guidance. (→P.111)

- Fuel economy display

Select to change the average fuel consumption display between after start/after reset/after refuel. (→P.110)

-  (if equipped)

Select to display/not display the audio system linked display.



Select to change the displayed content of the following:

- Display contents

Select to display/not display the energy monitor. (→P.120)

- Drive information type

Select to change the drive information type display between after start/after reset.

- Drive information items

Select to set the first and second items

of the drive information display to any of the following: average vehicle speed/distance/elapsed time.

- Current trip result display

Select to change the displayed information about the current trip, measured from when the hybrid system was started until it was stopped, between drive information/eco score. (The information will be displayed temporarily when the hybrid system is stopped.)

- Pop-up display

Select to enable/disable pop-up displays for each relevant system.

- Multi-information display off

Select to turn the multi-information display off.

To turn the multi-information display on again, press any of the following meter control switches

 /  /  /  / OK / .

- Default setting

Select to reset the meter display settings to the default setting.

■ Vehicle functions and settings that can be changed

→P.431

■ Suspension of the settings display

- Some settings cannot be changed while driving. When changing settings, park the vehicle in a safe place.
- If a warning message is displayed, operation of the settings display will be suspended.

**WARNING****■ Cautions during setting up the display**

If the hybrid system is operating while changing certain settings on the settings display, ensure that the vehicle is parked in a place with adequate ventilation. In a closed area such as a garage, exhaust gases including harmful carbon monoxide (CO) may collect and enter the vehicle. This may lead to death or a serious health hazard.

**NOTICE****■ During setting up the display**

To prevent 12-volt battery discharge, ensure that the hybrid system is operating while setting up the display features.

Head-up display*

*: If equipped

The head-up display projects a variety of driving-related information and the operating state of the driving support systems on the windshield.

System components

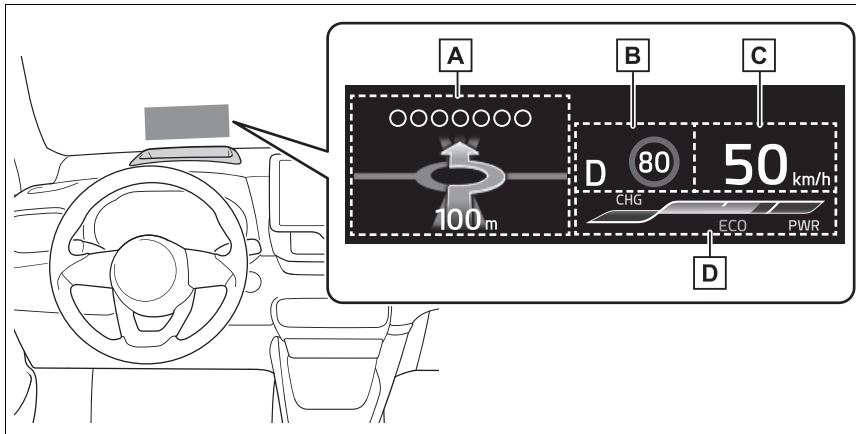

Illustrations used in this text are intended as examples, and may differ from the image that is actually displayed by the head-up display.

- A** Driving support system status (if equipped)/navigation system-linked display area (if equipped) (→P.118)
- B** Shift position display/RSA (Road Sign Assist) display area (if equipped) (→P.181, 244)
- C** Vehicle speed display
- D** Hybrid System Indicator/Tachometer/Outside temperature display area (→P.119)

■ Head-up display will operate when

The power switch is in ON.

■ When using the head-up display

The head-up display may seem dark or hard to see when viewed through sun-

glasses, especially polarized sunglasses. Adjust the brightness of the head-up display or remove your sunglasses.

■ Street name display (vehicles with navigation system)

Only street names which are included in the map data will be displayed.

WARNING

■ When using the head-up display

- Check that the position and brightness of the head-up display image does not interfere with safe driving. Incorrect adjustment of the image's position or brightness may obstruct the driver's view and lead to an accident, resulting in death or serious injury.
- Do not continuously look at the head-up display while driving as you may fail to see pedestrians, objects on the road, etc., ahead of the vehicle.

NOTICE

■ Head-up display projector

- Do not place any drinks near the head-up display projector. If the projector gets wet, electrical malfunctions may result.

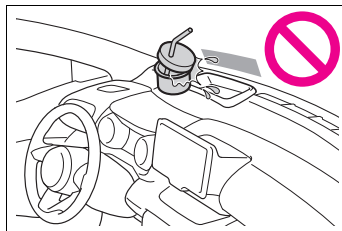

- Do not place anything on or put stickers onto the head-up display projector. Doing so could interrupt head-up display indications.
- Do not touch the inside of the head-up display projector or thrust sharp edges or the like into the projector. Doing so could cause mechanical malfunctions.

Using the head-up display

Select  on the multi-information display (→P.431) and then “HUD Main”.

■ Enabling/disabling the head-up display

Press the OK meter control switch to enable/disable the head-up display.

■ Changing the head-up display settings

Press and hold the OK meter control switch to change the following settings:

- Brightness and vertical position of the head-up display

Select to adjust the brightness or vertical position of the head-up display.

- Display content

Select to change the display between the following:

- No content
- Hybrid System Indicator
- Tachometer
- Select to enable/disable the following items:
 - Route guidance to destination (if equipped)
 - Driving support system display (if equipped)
 - Compass (heading-up display) (if equipped)
 - Audio system operation status (if equipped)

- Display angle

Select to adjust the angle of the head-up display.

- **Enabling/disabling of the head-up display**

If the head-up display is disabled, it will remain disabled when the power switch is turned off then back to ON.

- **Display brightness**

The brightness of the head-up display can be adjusted on  of the multi-information display. Also, it is automatically adjusted according to the ambient brightness.



WARNING

- **Caution for changing settings of the head-up display**

If the hybrid system is operating while changing certain settings on the settings display, ensure that the vehicle is parked in a place with adequate ventilation. In a closed area such as a garage, exhaust gases including harmful carbon monoxide (CO) may collect and enter the vehicle. This may lead to death or a serious health hazard.



NOTICE

- **When changing the settings of the head-up display**

To prevent 12-volt battery discharge, ensure that the hybrid system is operating while changing the settings of the head-up display.

Driving support system status/navigation system-linked display area

- **Driving support system status display**

Displays the operational status of the following systems:

- Dynamic radar cruise control with full-speed range (if equipped) (→P.230)
- LTA (Lane Tracing Assist) (if equipped) (→P.220)

Details of content displayed on the head-up display may differ from that displayed on the multi-information display. For details, refer to the explanation of each system.

- **Navigation system-linked display area (if equipped)**

Displays the following items which are linked to the navigation system:

- Street name
- Route guidance to destination (if equipped)
- Compass (heading-up display)

Pop-up display

Pop-up displays for the following systems will be displayed when necessary:

- **Driving support systems**

Displays a warning/suggestion/advice message or the operating state of a relevant system.

- PCS (Pre-Collision System) (if

equipped) (→P.209)

- LTA (Lane Tracing Assist) (if equipped) (→P.220)
- PKSB (Parking Support Brake) (if equipped) (→P.265)
- Brake Override System (→P.160)
- Drive-Start Control (→P.165)

Details of content displayed on the head-up display may differ from that displayed on the multi-information display. For details, refer to the explanation of each system.

■ icon

Displayed when a warning message is displayed on the multi-information display. (→P.383)

■ Warning message

Some warning messages are displayed when necessary, according to certain conditions.

Details of content displayed on the head-up display may differ from that displayed on the multi-information display.

■ Audio system operation status (if equipped)

Displayed when an audio remote control switch on the steering wheel is operated.

■ Hands-free system status (if equipped)

Displayed when the hands-free system is operated.

■ When a pop-up display is displayed

When a pop-up display is displayed, a current display may no longer be displayed. In this case, the display will return after the pop-up display disappears.

Hybrid System Indicator/Tachometer/Outside temperature display

■ Hybrid System Indicator

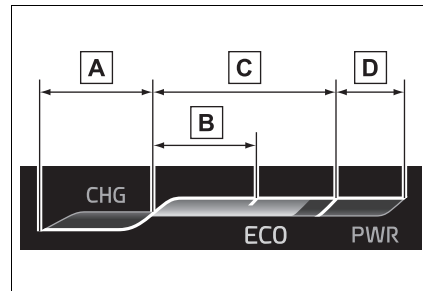

A Charge area

B Hybrid Eco area

C Eco area

D Power area

Displayed content is the same as that displayed on the multi-information display (Hybrid System Indicator). For details, refer to P.95, 100.

■ Tachometer

Displays the engine speed in revolutions per minute.

■ Outside temperature display

Displayed when the power switch is turned to ON or when the low outside temperature indicator is flashing.

■ **Outside temperature display**

- When the ambient temperature is approximately 3°C (37°F) or lower, the low outside temperature indicator will flash for approximately 10 seconds and the outside temperature display will turn off. In this case, the display will be displayed again when the outside temperature becomes approximately 5°C (41°F) or higher.
- In the following situations, the correct outside temperature may not be displayed, or the display may take longer than normal to change:
 - When stopped, or driving at low speeds (less than 25 km/h [16 mph])
 - When the outside temperature has changed suddenly (at the entrance/exit of a garage, tunnel, etc.)
- When "--" or "E" is displayed, the system may be malfunctioning. Take your vehicle to any authorized Toyota retailer or Toyota authorized repairer, or any reliable repairer.

Energy monitor/consumption screen*

*: If equipped

The state of the hybrid system can be viewed on the multi-information display and multimedia system screen.

System components

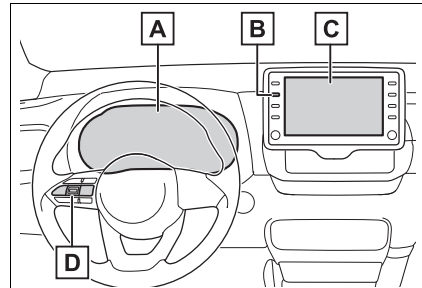

- A** Multi-information display
- B** "MENU" button
- C** Multimedia system screen
- D** Meter control switches

Energy monitor

The energy monitor can be used to check the vehicle drive status, hybrid system operation status and energy regeneration status.

■ **Display procedure**

- ▶ Multi-information display

Press < / > (vertical display) or

^ / v (horizontal display) of the

meter control switches on the steering wheel and select , press \wedge / \vee (vertical display) or \leftarrow / \rightarrow (horizontal display) of the meter control switches and select the energy monitor.

▶ 7-inch/8-inch display multimedia system

- 1 Press the "MENU" button.
- 2 Select "Info" on the "Menu" screen.
- 3 Select "ECO" on the "Information" screen.*

*: Models with navigation function only

If a screen other than "Energy monitor" is displayed, select "Energy".

▶ 9-inch display multimedia system

- 1 Press the "HOME" button.
- 2 Select "Vehicle" on the "Home" screen.

If a screen other than "Energy monitor" is displayed, select "Energy flow".

■ **Display**

When energy is flowing, an arrow appears to show the direction of the flow of energy. When energy is not flowing, an arrow is not displayed.

Green: Shows that the electrical energy charging or recovering.

Yellow: Shows that the electrical energy using.

Red: Shows that the gasoline engine power using.

▶ Multi-information display (ex. vertical display)

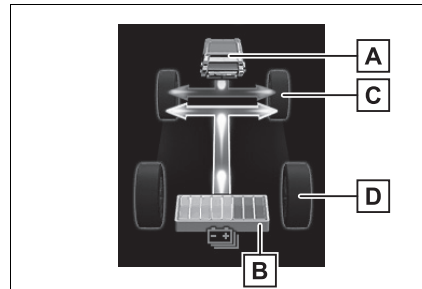

The figure shows all the arrows for the purpose of this explanation, but the actual contents of the display will differ.

- A** Gasoline engine
- B** Hybrid battery (traction battery)
- C** Front tires
- D** Rear tires

▶ Multimedia system (7-inch/8-inch display)

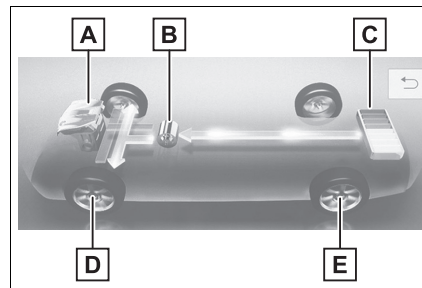

The figure shows all the arrows for the purpose of this explanation, but the actual contents of the display will differ.

- A** Gasoline engine
- B** Electric motor (traction motor)
- C** Hybrid battery (traction battery)
- D** Front tires

E Rear tires

- ▶ Multimedia system (7-inch/8-inch display) (on “Home” screen)

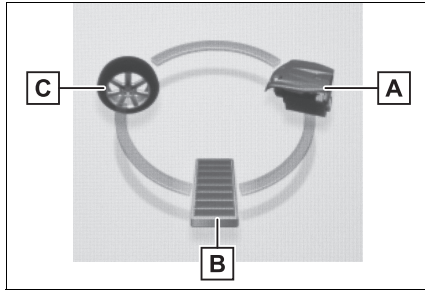

A Gasoline engine

B Hybrid battery (traction battery)

C Tires

- ▶ Multimedia system (9-inch display)

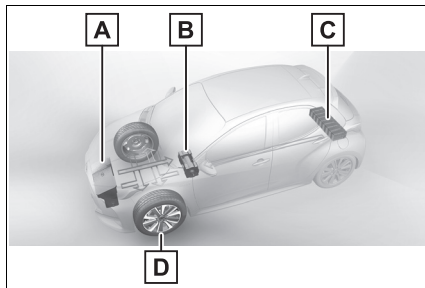

The figure shows all the arrows for the purpose of this explanation, but the actual contents of the display will differ.

A Gasoline engine

B Electric motor (traction motor)

C Hybrid battery (traction battery)

D Front tires

Hybrid battery (traction battery) status

The display changes in 8 levels according to the remaining charge amount of the hybrid battery (traction battery).

- The figure shows the multi-information display as an example for explanation.
- These images are examples only, and may vary slightly from actual conditions.

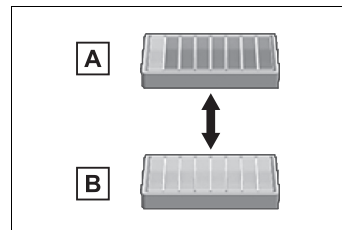

A Low

B High

Remaining charge amount warning of hybrid battery (traction battery)

- The buzzer sounds intermittently when the hybrid battery (traction battery) remains without charging while the shift lever is in N, or the remaining charge amount drops below a certain level. If the remaining charge amount drops further, the buzzer sounds continuously.
- When a warning message is shown on the multi-information display and the buzzer sounds, follow the instructions displayed on the screen to perform troubleshooting.

Consumption (vehicles with 7-inch/8-inch display multi-media system)

Trip information

- 1 Press the “MENU” button.

2 Select “Info” on the “Menu” screen.

If a screen other than “Trip information” is displayed, select “Trip information”.

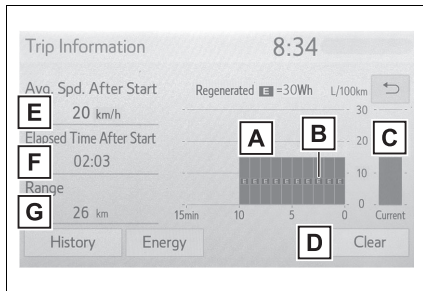

A Fuel consumption in the past 15 minutes

B Regenerated energy in the past 15 minutes

One symbol indicates 30 Wh. Up to 5 symbols are shown.

C Current fuel consumption

D Resetting the consumption data

E Average vehicle speed since the hybrid system was started.

F Elapsed time since the hybrid system was started.

G Cruising range

The average fuel consumption history is divided by color into past averages and the average fuel consumption since the last updated.

Use the displayed average fuel consumption as a reference.

The image is an example only, and may vary slightly from actual conditions.

History

1 Press the “MENU” button.

2 Select “Info” on the “Menu” screen.

If a screen other than “History” is displayed, select “History”.

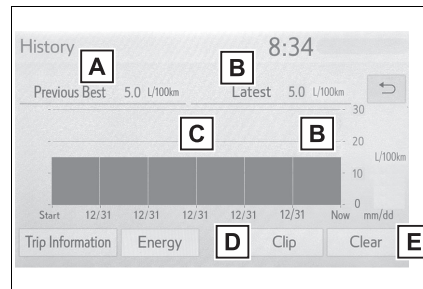

A Best recorded fuel consumption

B Latest fuel consumption

C Previous fuel consumption record

D Updating the latest fuel consumption data

E Resetting the history data

The average fuel consumption history is divided by color into past averages and the average fuel consumption since the last updated.

Use the displayed average fuel consumption as a reference.

The image is an example only, and may vary slightly from actual conditions.

Updating the history data

Update the latest fuel consumption by selecting “Clip” to measure the current fuel consumption again.

Resetting the data

The fuel consumption data can be

deleted by selecting “Clear”.

■ **Cruising range**

Displays the estimated maximum distance that can be driven with the quantity of fuel remaining.

This distance is computed based on your average fuel consumption. As a result, the actual distance that can be driven may differ from that displayed.

■ **“Home” screen**

The average fuel consumption and distance to empty can be displayed on the “Home” screen of the multimedia display.

For details of the “Home” screen, refer to the separate “Navigation and multimedia system Owner’s manual”.

Consumption (vehicles with 9-inch display multimedia system)

■ **Drive information**

- 1 Press the “HOME” button.
- 2 Select “Vehicle” on the “Home” screen.

If a screen other than “Drive information” is displayed, select “Drive info”.

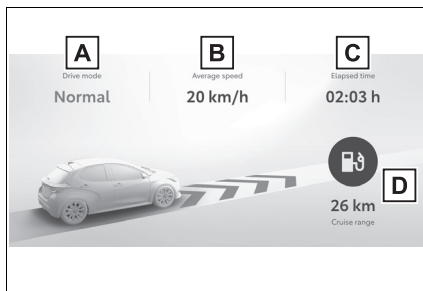

- A** Selected drive mode (→P.275)
- B** Average speed vehicle speed since the vehicle was started.

- C** Elapsed time since the hybrid system was started

- D** Cruising range

■ **Fuel consumption**

- 1 Press the “HOME” button.
- 2 Select “Vehicle” on the “Home” screen.

If a screen other than “Fuel consumption” is displayed, select “Fuel consumption”.

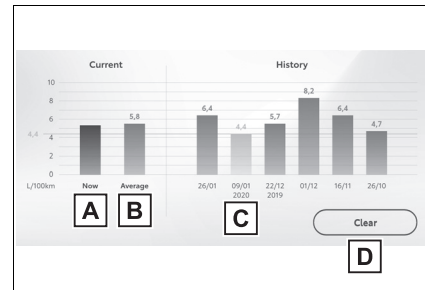

- A** Current fuel consumption
- B** Latest fuel consumption
- C** Previous fuel consumption record
- D** Resetting the history data

The average fuel consumption history is divided by color into past averages (blue) and lowest average (green).

The image is an example only, and may vary slightly from actual conditions.

■ **Updating the history data**

Update the latest fuel consumption by resetting “Total average” on multi-information display to measure the current fuel consumption again.

■ **Resetting the data**

The fuel consumption data can be

deleted by selecting "Clear".

■ **Cruising range**

Displays the estimated maximum distance that can be driven with the quantity of fuel remaining.

This distance is computed based on your average fuel consumption. As a result, the actual distance that can be driven may differ from that displayed.

- 3-1. Key information**
 - Keys.....128
- 3-2. Opening, closing and locking the doors**
 - Side doors133
 - Back door137
 - Smart entry & start system 140
- 3-3. Adjusting the seats**
 - Front seats.....145
 - Rear seats146
 - Head restraints147
- 3-4. Adjusting the steering wheel and mirrors**
 - Steering wheel.....151
 - Inside rear view mirror152
 - Outside rear view mirrors .153
- 3-5. Opening and closing the windows**
 - Power windows.....156

Keys

The keys

The following keys are provided with the vehicle.

- ▶ Vehicles without a smart entry & start system (type A)

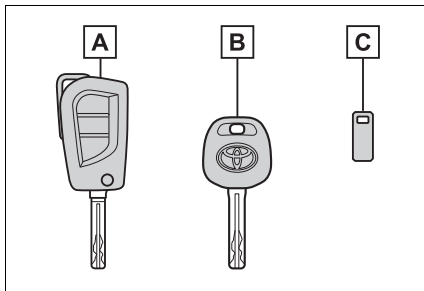

- A** Key (with a wireless remote control function)

Operating the wireless remote control function (→P.130)

- B** Key (without a wireless remote control function)

- C** Key number plate

- ▶ Vehicles without a smart entry & start system (type B)

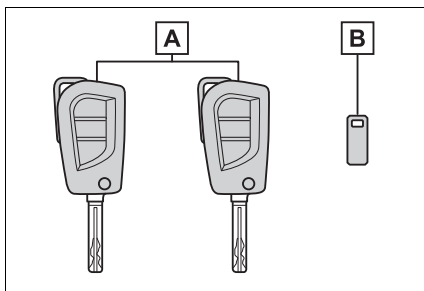

- A** Key (with a wireless remote control function)

Operating the wireless remote control function (→P.130)

- B** Key number plate

- ▶ Vehicles with a smart entry & start system

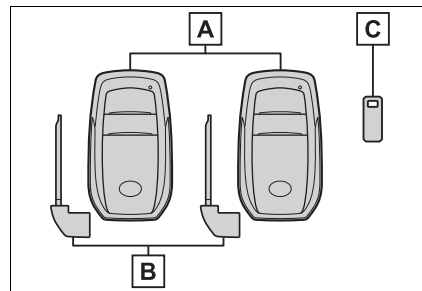

- A** Electronic keys

- Operating the smart entry & start system (→P.140)
- Operating the wireless remote control function (→P.130)

- B** Mechanical keys

- C** Key number plate

When riding in an aircraft

When bringing a key with wireless remote control function onto an aircraft, make sure you do not press any buttons on the key while inside the aircraft cabin. If you are carrying the key in your bag, etc., ensure that the buttons are not likely to be pressed accidentally. Pressing a button may cause the key to emit radio waves that could interfere with the operation of the aircraft.

Key battery depletion (vehicles without a smart entry & start system)

- The standard battery life is 1 to 2 years.
- The battery will become depleted even if the key is not used. The following symptoms indicate that the key

battery may be depleted. Replace the battery when necessary. (→P.351)

- The wireless remote control does not operate.
- The detection area becomes smaller.

■ Key battery depletion (vehicles with a smart entry & start system)

- The standard battery life is 1 to 2 years.
- If the battery becomes low, an alarm will sound in the cabin and a message will be shown on the multi-information display when the hybrid system is stopped.
- To reduce key battery depletion when the electronic key is to not be used for long periods of time, set the electronic key to the battery-saving mode. (→P.141)
- As the electronic key always receives radio waves, the battery will become depleted even if the electronic key is not used. The following symptoms indicate that the electronic key battery may be depleted. Replace the battery when necessary. (→P.351)
 - The smart entry & start system or the wireless remote control does not operate.
 - The detection area becomes smaller.
 - The LED indicator on the key surface does not turn on.
- To avoid serious deterioration, do not leave the electronic key within 1 m (3 ft.) of the following electrical appliances that produce a magnetic field:
 - TVs
 - Personal computers
 - Cellular phones, cordless phones and battery chargers
 - Recharging cellular phones or cordless phones
 - Table lamps
 - Induction cookers
- If the electronic key is near the vehicle for longer than necessary, even if the smart entry & start system is not operated, the key battery may become depleted faster than normal.

■ Replacing the battery

→P.351

■ If “A New Key has been Registered Contact Your Dealer for Details” is shown on the multi-information display (vehicles with a smart entry & start system)

This message will be displayed each time the driver's door is opened when the doors are unlocked from the outside for approximately 10 days after a new electronic key has been registered. If this message is displayed but you have not had a new electronic key registered, ask any authorized Toyota retailer or Toyota authorized repairer, or any reliable repairer to check if an unknown electronic key (other than those in your possession) has been registered.

■ If a wrong key is used

The key cylinder rotates freely, isolated from the internal mechanism.



NOTICE

■ To prevent key damage

- Do not drop the keys, subject them to strong shocks, or bend them.
- Do not expose the keys to high temperatures for long periods of time.
- Do not get the keys wet or wash them in an ultrasonic washer, etc.
- Vehicles with a smart entry & start system: Do not attach metallic or magnetic materials to the keys or place the keys close to such materials.
- Do not disassemble the keys.
- Do not attach a sticker or anything else to the surface of the key.



NOTICE

● Vehicles with a smart entry & start system: Do not place the keys near objects that produce magnetic fields, such as TVs, audio systems and induction cookers, or medical electrical equipment, such as low-frequency therapy equipment.

■ **Carrying the electronic key on your person (vehicles with a smart entry & start system)**

Carry the electronic key 10 cm (3.9 in.) or more away from electric appliances that are turned on. Radio waves emitted from electric appliances within 10 cm (3.9 in.) of the electronic key may interfere with the key, causing the key to not function properly.

■ **In case of a smart entry & start system malfunction or other key-related problems (vehicles with a smart entry & start system)**

→P.407

■ **When an electronic key is lost (vehicles with a smart entry & start system)**

→P.407

Wireless remote control

The keys are equipped with the following wireless remote control:

▶ Vehicles without a smart entry & start system

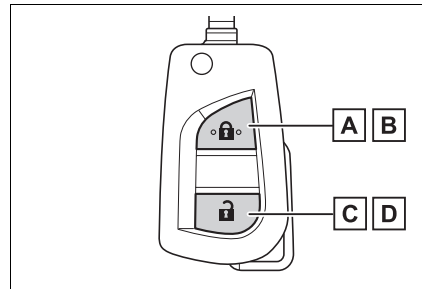

- A** Locks the doors (→P.133)
- B** Closes the windows* (→P.133)
- C** Unlocks the doors (→P.133)
- D** Opens the windows* (→P.133)

▶ Vehicles with a smart entry & start system

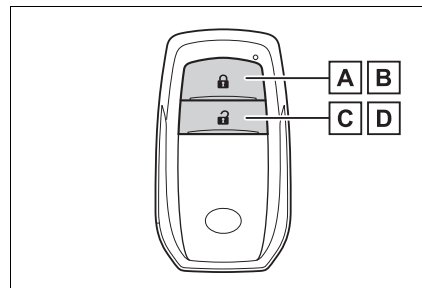

- A** Locks the doors (→P.133)
- B** Closes the windows* (→P.133)
- C** Unlocks the doors (→P.133)
- D** Opens the windows* (→P.133)

*: This setting must be customized at any authorized Toyota retailer or Toyota authorized repairer, or any reliable repairer.

■ Conditions affecting the operation of the wireless remote control (vehicles without a smart entry & start system)

The wireless remote control function may not operate normally in the following situations:

- When the wireless key battery is depleted
- Near a TV tower, electric power plant, gas station, radio station, large display, airport or other facility that generates strong radio waves or electrical noise
- When carrying a portable radio, cellular phone or other wireless communication devices
- When the wireless key is in contact with, or is covered by a metallic object
- When another wireless key (that emits radio waves) is being used nearby
- If window tint with a metallic content or metallic objects are attached to the rear window

■ Conditions affecting the operation of the smart entry & start system or wireless remote control (vehicles with a smart entry & start system)

→P.142

Using the key (vehicles without a smart entry & start system)

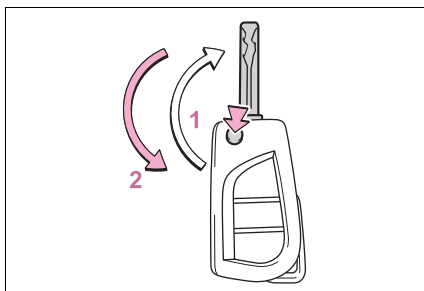

1 Releasing

To release the key, press the button

2 Folding

To stow the key, press the button then fold the key.

Using the mechanical key (vehicles with a smart entry & start system)

To take out the mechanical key, slide the release lever **A** and take the key out.

The mechanical key can only be inserted in one direction, as the key only has grooves on one side. If the key cannot be inserted in a lock cylinder, turn it over and re-attempt to insert it.

After using the mechanical key, store it in the electronic key. Carry the mechanical key together with the electronic key. If the electronic key battery is depleted or the entry function does not operate properly, you will need the mechanical key. (→P.407)

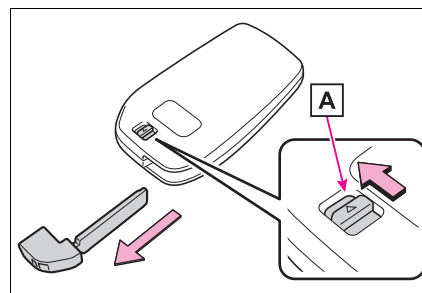

■ If you lose your mechanical keys

→P.407

3

Before driving

132 3-1. Key information

- **Certification for the wireless remote control**

→P.453

Side doors

Unlocking and locking the doors from the outside

■ Using the entry function (vehicles with a smart entry & start system)

Carry the electronic key to enable this function.

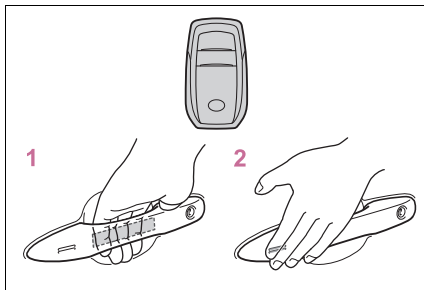

- 1** Grip the front door handle to unlock all the doors.

Make sure to touch the sensor on the back of the handle.

The doors cannot be unlocked for 3 seconds after the doors are locked.

- 2** Touch the lock sensor (the indentation on the side of the front door handle) to lock all the doors.

Check that the door is securely locked.

■ Wireless remote control

- ▶ Vehicles without a smart entry & start system

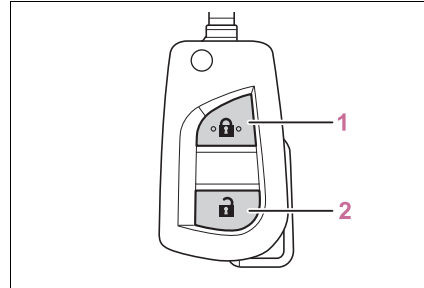

- 1** Locks all the doors

Check that the door is securely locked.

Press and hold to close the windows.*

- 2** Unlocks all the doors

Press and hold to open the windows.*

- ▶ Vehicles with a smart entry & start system

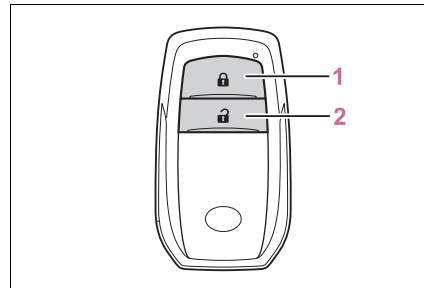

- 1** Locks all the doors

Check that the door is securely locked.

Press and hold to close the windows.*

- 2** Unlocks all the doors

Press and hold to open the windows.*

*: This setting must be customized at any authorized Toyota retailer or Toyota authorized repairer, or any reliable repairer.

3

Before driving

■ **Key**

Turning the key operates the doors as follows:

- ▶ Vehicles without a smart entry & start system

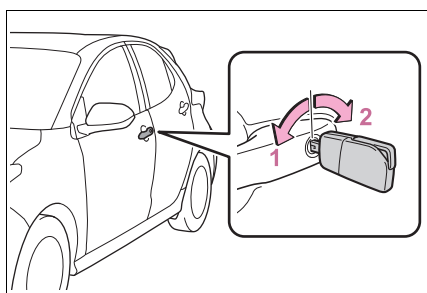

- 1 Locks all the doors

Turn and hold to close the windows.*

- 2 Unlocks all the doors

Turn and hold to open the windows.*

*: This setting must be customized at any authorized Toyota retailer or Toyota authorized repairer, or any reliable repairer.

- ▶ Vehicles with a smart entry & start system

The doors can also be locked and unlocked with the mechanical key. (→P.408)

■ **Operation signals**

- ▶ Vehicles without a smart entry & start system

The emergency flashers flash to indicate that the doors have been locked/unlocked using the wireless remote control. (Locked: Once; Unlocked: Twice)

- ▶ Vehicles with a smart entry & start system

The emergency flashers flash to indicate

that the doors have been locked/unlocked using the entry function or wireless remote control. (Locked: Once; Unlocked: Twice)

A buzzer sounds to indicate that the windows are operating.

■ **Security feature**

- ▶ Vehicles without a smart entry & start system

If a door is not opened within approximately 30 seconds after the vehicle is unlocked using the wireless remote control, the security feature automatically locks the vehicle again.

- ▶ Vehicles with a smart entry & start system

If a door is not opened within approximately 30 seconds after the vehicle is unlocked using the entry function or wireless remote control, the security feature automatically locks the vehicle again.

■ **When the door cannot be locked by the lock sensor on the surface of the front door handle (vehicles with a smart entry & start system)**

If the doors cannot be locked by touching the lock sensor with a finger, touch the lock sensor with the palm of your hand.

If you are wearing gloves, remove them.

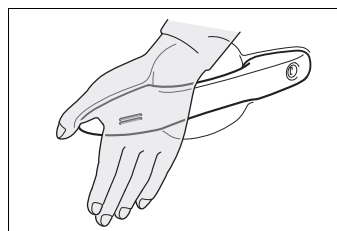

■ **Door lock buzzer (vehicles with a smart entry & start system)**

If an attempt to lock the doors using the entry function or wireless remote control is made when a door is not fully closed,

a buzzer will sound continuously for 5 seconds. Fully close the door to stop the buzzer, and lock the doors again.

■ Alarm (if equipped)

Locking the doors will set the alarm system. (→P.86)

■ Conditions affecting the operation of the smart entry & start system or wireless remote control

▶ Vehicles without a smart entry & start system

→P.131

▶ Vehicles with a smart entry & start system

→P.142

■ If the smart entry & start system or the wireless remote control does not operate properly

▶ Vehicles without a smart entry & start system

Replace the key battery with a new one if it is depleted. (→P.351)

▶ Vehicles with a smart entry & start system

Use the mechanical key to lock and unlock the doors. (→P.408)

Replace the key battery with a new one if it is depleted. (→P.351)

■ If the 12-volt battery is discharged (vehicles with a smart entry & start system)

The doors cannot be locked and unlocked using the entry function or wireless remote control. Lock or unlock the doors using the mechanical key. (→P.408)

■ Rear seat reminder function

● In order to remind you not to forget luggage, etc., in the rear seat, when the power switch is turned to OFF after any of the following conditions are met, a buzzer will sound and a message will be displayed on the multi-information display for approximately 6 seconds.

- The hybrid system is started within 10 minutes after opening and closing a rear door.
- A rear door has been opened and closed after the hybrid system was started.

However, if a rear door is opened and then closed within approximately 2 seconds, the rear seat reminder function may not operate.

● The rear seat reminder function determines that luggage, etc., has been placed in a rear seat based on opening and closing of a rear door. Therefore, depending on the situation, the rear seat reminder function may not operate and you may still forget luggage, etc., in the rear seat, or it may operate unnecessarily.

● The rear seat reminder function can be enabled/disabled. (→P.431)

■ Customization

Some functions can be customized. (→P.431)

WARNING

■ To prevent an accident

Observe the following precautions while driving the vehicle. Failure to do so may result in a door opening and an occupant being thrown out of the vehicle, resulting in death or serious injury.

- Ensure that all doors are properly closed and locked.
- Do not pull the inside door handle while driving. Be especially careful of the front doors, as the doors may be opened even if the inside lock buttons are in the locked position.
- Set the rear door child-protector locks when children are seated in the rear seats.

WARNING

- When opening or closing a door**
 Check the surroundings of the vehicle such as whether the vehicle is on an incline, whether there is enough space for a door to open and whether a strong wind is blowing. When opening or closing the door, hold the door handle tightly to prepare for any unpredictable movement.
- When using the wireless remote control or the key and operating the power windows**
 Operate the power windows after checking to make sure that there is no possibility of any passenger having any of their body parts caught in the windows. Also, do not allow children to operate the wireless remote control or the key. It is possible for children and other passengers to get caught in the power windows.

Unlocking and locking the doors from the inside

■ Door lock switches (to lock/unlock)

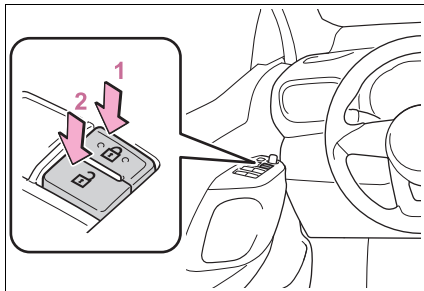

- 1 Locks all the doors
- 2 Unlocks all the doors

■ Inside lock buttons

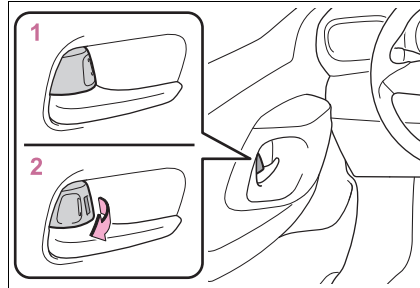

- 1 Locks the door
- 2 Unlocks the door

The front doors can be opened by pulling the inside handle even if the lock buttons are in the lock position.

■ Locking the front doors from the outside without a key

- 1 Move the inside lock button to the lock position.
 - 2 Close the door while pulling the door handle.
- ▶ Vehicles without a smart entry & start system

The door cannot be locked if the key is in the power switch.

- ▶ Vehicles with a smart entry & start system

The door cannot be locked if the power switch is in ACC or ON, or the electronic key is left inside the vehicle.

The key may not be detected correctly and the door may be locked.

■ Open door warning buzzer

If a door or the back door is not fully closed, a buzzer will sound when the vehicle speed reaches 5 km/h (3 mph).

The open door(s) or back door is indicated on the multi-information display.

Rear door child-protector lock

The door cannot be opened from inside the vehicle when lock is set.

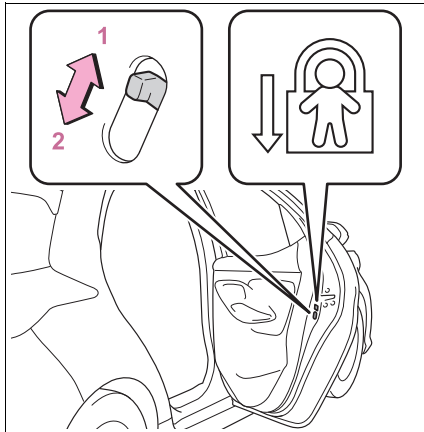

1 Unlock

2 Lock

These locks can be set to prevent children from opening the rear doors. Push down on each rear door switch to lock both rear doors.

Back door

The back door can be locked/unlocked and opened/closed by the following procedures.

⚠ WARNING

Observe the following precautions. Failure to do so may result in death or serious injury.

■ Caution while driving

- Keep the back door closed while driving. If the back door is left open, it may hit near-by objects while driving or luggage may be unexpectedly thrown out, causing an accident.

In addition, exhaust gases may enter the vehicle, causing death or a serious health hazard. Make sure to close the back door before driving.

- Before driving the vehicle, make sure that the back door is fully closed. If the back door is not fully closed, it may open unexpectedly while driving, causing an accident.
- Never let anyone sit in the luggage compartment. In the event of sudden braking or a collision, they are susceptible to death or serious injury.

■ When children are in the vehicle

- Do not allow children to play in the luggage compartment. If a child is accidentally locked in the luggage compartment, they could have heat exhaustion or other injuries.

3

Before driving

⚠ WARNING

- Do not allow a child to open or close the back door. Doing so may cause the back door to move unexpectedly, or cause the child's hands, head, or neck to be caught by the closing back door.

■ Operating the back door

Observe the following precautions. Failure to do so may cause parts of the body to be caught, resulting in death or serious injury.

- Remove any heavy loads, such as snow and ice, from the back door before opening it. Failure to do so may cause the back door to suddenly shut again after it is opened.
- When opening or closing the back door, thoroughly check to make sure the surrounding area is safe.
- If anyone is in the vicinity, make sure they are safe and let them know that the back door is about to open or close.
- Use caution when opening or closing the back door in windy weather as it may move abruptly in strong wind.
- The back door may suddenly shut if it is not opened fully. It is more difficult to open or close the back door on an incline than on a level surface, so beware of the back door unexpectedly opening or closing by itself. Make sure that the back door is fully open and secure before using the luggage compartment.

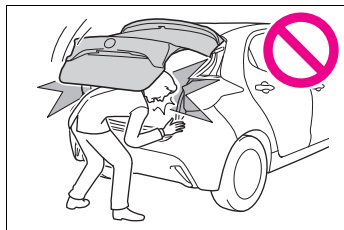

- When closing the back door, take extra care to prevent your fingers, etc., from being caught.

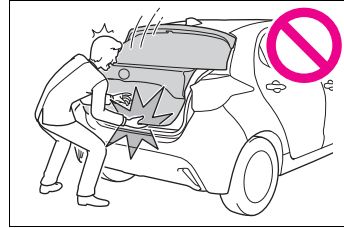

- When closing the back door, make sure to press it lightly on its outer surface. If the back door handle is used to fully close the back door, it may result in hands or arms being caught.
- Do not pull on the back door damper stay (→P.140) to close the back door, and do not hang on the back door damper stay. Doing so may cause hands to be caught or the back door damper stay to break, causing an accident.
- If a bicycle carrier or similar heavy object is attached to the back door, it may suddenly shut again after being opened, causing someone's hands, head or neck to be caught and injured. When installing an accessory part to the back door, using a genuine Toyota part is recommended.

Unlocking and locking the back door from the outside

- **Using the entry function (vehicles with a smart entry & start system)**

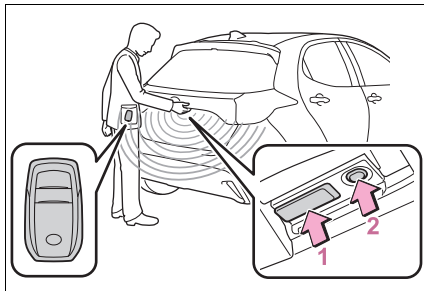

- 1 Unlocks all the doors

The door cannot be unlocked for 3 seconds after the door is locked.

- 2 Locks all the doors

Check that the door is securely locked.

- **Wireless remote control**

→P.133

- **Key**

→P.134

- **Operation signals**

→P.134

Unlocking and locking the back door from the inside

- **Door lock switches**

→P.136

Opening/closing the back door

- **Open**

Raise the back door while pushing up the back door opener switch.

The back door cannot be closed immediately after the back door opener switch is pushed.

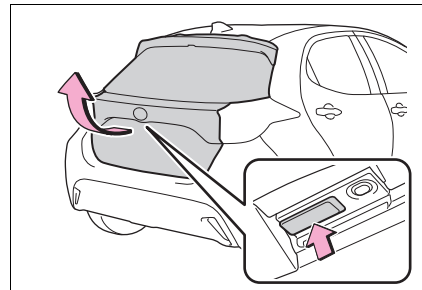

- **Close**

Lower the back door using a back door handle, and then push the back door from the outside to close it.

Be careful not to pull the back door sideways when closing the back door with the handle.

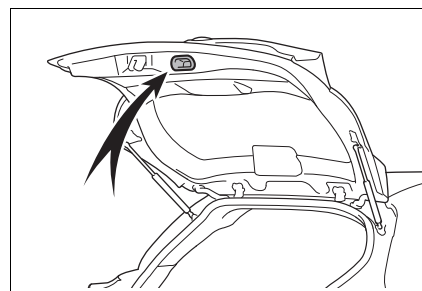

- **Open door warning buzzer**

→P.136

3

Before driving

■ **Luggage compartment light**

- The luggage compartment light turns on when the back door is opened.
- If the luggage compartment light is left on when the power switch is turned off, the light will go off automatically after 20 minutes.

 **NOTICE**

■ **Back door damper stays**

The back door is equipped with damper stays that hold the back door in place. Observe the following precautions. Failure to do so may cause damage to the back door damper stay, resulting in malfunction.

- Do not attach any foreign objects, such as stickers, plastic sheets, or adhesives to the damper stay rod.

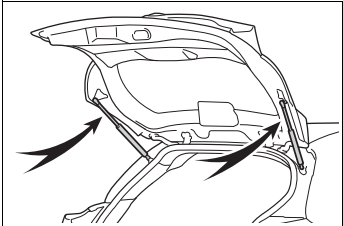

- Do not touch the damper stay rod with gloves or other fabric items.
- Do not attach any accessories other than genuine Toyota parts to the back door.
- Do not place your hand on the damper stay or apply lateral forces to it.

Smart entry & start system*

*: If equipped

The following operations can be performed simply by carrying the electronic key on your person, for example in your pocket. The driver should always carry the electronic key.

- Locks and unlocks the doors (→P.133)
- Locks and unlocks the back door (→P.139)
- Starts the hybrid system (→P.175)

■ **Antenna location**

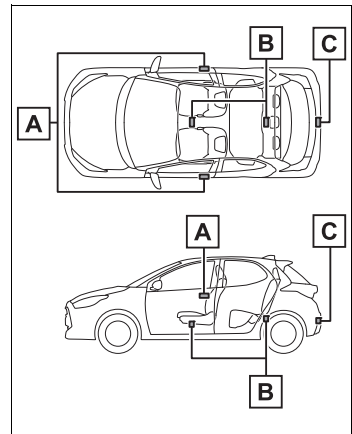

- A** Antennas outside the cabin
- B** Antennas inside the cabin
- C** Antenna outside the luggage compartment

■ **Effective range (areas within which the electronic key is detected)**

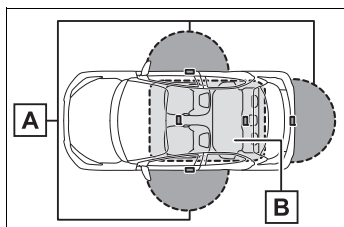

A When locking or unlocking the doors

The system can be operated when the electronic key is within about 0.7 m (2.3 ft.) of an outside front door handle and back door. (Only the doors detecting the key can be operated.)

B When starting the hybrid system or changing power switch modes

The system can be operated when the electronic key is inside the vehicle.

■ **Alarms and warning messages**

A combination of exterior and interior buzzers as well as warning messages shown on the multi-information display are used to prevent theft of the vehicle and accidents resulting from erroneous operation. Take appropriate measures based on the displayed message. (→P.383)

When only an alarm sounds, circumstances and correction procedures are as follows.

- Exterior buzzer sounds once for 5 seconds

Situation	Correction procedure
An attempt was made to lock the vehicle while a door was open.	Close all of the doors and lock the doors again.

- Interior buzzer sounds continuously

Situation	Correction procedure
The power switch was turned to ACC while the driver's door was open (or the driver's door was opened while the power switch was in ACC).	Turn the power switch off and close the driver's door.
The power switch was turned to off while the driver's door was open.	Close the driver's door.

■ **Battery-saving function**

The battery-saving function will be activated in order to prevent the electronic key battery and the 12-volt battery from being discharged while the vehicle is not operated for a long time.

- In the following situations, the smart entry & start system may take some time to unlock the doors.
 - The electronic key has been left within approximately 3.5 m (11 ft.) of the outside of the vehicle for 2 minutes or longer.
 - The smart entry & start system has not been used for 5 days or longer.
- If the smart entry & start system has not been used for 14 days or longer, the doors cannot be unlocked from any door except the driver's door. In this case, hold the driver's door handle, or use the wireless remote control or mechanical key to unlock the doors.

■ **Electronic key battery-saving function**

- When battery-saving mode is set, battery depletion is minimized by stopping the electronic key from receiving radio waves.

Press twice while pressing and

3

Before driving

holding . Confirm that the electronic key indicator flashes 4 times.

While the battery-saving mode is set, the smart entry & start system cannot be used. To cancel the function, press any of the electronic key buttons.

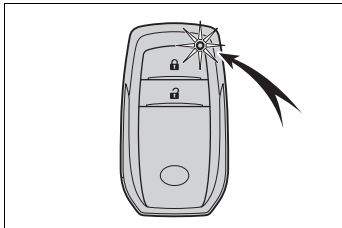

- Electronic keys that will not be used for long periods of time can be set to the battery-saving mode in advance.

■ **Conditions affecting operation**

The smart entry & start system uses weak radio waves. In the following situations, the communication between the electronic key and the vehicle may be affected, preventing the smart entry & start system, wireless remote control and immobilizer system from operating properly. (Ways of coping: →P.407)

- When the electronic key battery is depleted
- Near a TV tower, electric power plant, gas station, radio station, large display, airport or other facility that generates strong radio waves or electrical noise
- When carrying a portable radio, cellular phone, cordless phone or other wireless communication device
- When the electronic key is in contact with, or is covered by the following metallic objects
 - Cards to which aluminum foil is attached
 - Cigarette boxes that have aluminum foil inside
 - Metallic wallets or bags
 - Coins
 - Hand warmers made of metal

- Media such as CDs and DVDs
- When other wireless keys (that emit radio waves) are being used nearby
- When carrying the electronic key together with the following devices that emit radio waves
 - Another vehicle's electronic key or a wireless key that emits radio waves
 - Personal computers or personal digital assistants (PDAs)
 - Digital audio players
 - Portable game systems
- If window tint with a metallic content or metallic objects are attached to the rear window
- When the electronic key is placed near a battery charger or electronic devices
- When the vehicle is parked in a pay parking spot where radio waves are emitted

If the doors cannot be locked/unlocked using the smart entry & start system, lock/unlock the doors by performing any of the following:

- Bring the electronic key close to either front door handle and operate the entry function.
- Operate the wireless remote control.

If the doors cannot be locked/unlocked using the above methods, use the mechanical key. (→P.408)

If the hybrid system cannot be started using the smart entry & start system, refer to P.408.

■ **Note for the entry function**

- Even when the electronic key is within the effective range (detection areas), the system may not operate properly in the following cases:
 - The electronic key is too close to the window or outside door handle, near the ground, or in a high place when the doors are locked or unlocked.
 - The electronic key is on the instrument panel, luggage cover or floor, or in the door pockets or glove box when the hybrid system is started or power

switch modes are changed.

- Do not leave the electronic key on top of the instrument panel or near the door pockets when exiting the vehicle. Depending on the radio wave reception conditions, it may be detected by the antenna outside the cabin and the door will become lockable from the outside, possibly trapping the electronic key inside the vehicle.
 - As long as the electronic key is within the effective range, the doors may be locked or unlocked by anyone. However, only the doors detecting the electronic key can be used to unlock the vehicle.
 - Even if the electronic key is not inside the vehicle, it may be possible to start the hybrid system if the electronic key is near the window.
 - The doors may unlock or lock if a large amount of water splashes on the door handle, such as in the rain or in a car wash when the electronic key is within the effective range. (The doors will automatically be locked after approximately 30 seconds if the doors are not opened and closed.)
 - If the wireless remote control is used to lock the doors when the electronic key is near the vehicle, there is a possibility that the door may not be unlocked by the entry function. (Use the wireless remote control to unlock the doors.)
 - Touching the door lock or unlock sensor while wearing gloves may prevent lock or unlock operation.
 - When the lock operation is performed using the lock sensor, recognition signals will be shown up to two consecutive times. After this, no recognition signals will be given.
 - If the door handle becomes wet while the electronic key is within the effective range, the door may lock and unlock repeatedly. In that case, follow the following correction procedures to wash the vehicle:
 - Place the electronic key in a location 2 m (6 ft.) or more away from the vehicle. (Take care to ensure that the key is not stolen.)
 - Set the electronic key to battery-saving mode to disable the smart entry & start system. (→P.141)
 - If the electronic key is inside the vehicle and a door handle becomes wet during a car wash, a message may be shown on the multi-information display and a buzzer will sound outside the vehicle. To turn off the alarm, lock all the doors.
 - The lock sensor may not work properly if it comes into contact with ice, snow, mud, etc. Clean the lock sensor and attempt to operate it again.
 - A sudden handle operation or a handle operation immediately after entering the effective range may prevent the doors from being unlocked. Touch the door unlock sensor and check that the doors are unlocked before pulling the door handle again.
 - If there is another electronic key in the detection area, it may take slightly longer to unlock the doors after the door handle is gripped.
- **When the vehicle is not driven for extended periods**
- To prevent theft of the vehicle, do not leave the electronic key within 2 m (6 ft.) of the vehicle.
 - The smart entry & start system can be deactivated in advance. (→P.431)
 - Setting the electronic key to battery-saving mode helps to reduce key battery depletion. (→P.141)
- **To operate the system properly**
- Make sure to carry the electronic key when operating the system. Do not get the electronic key too close to the vehicle when operating the system from the outside of the vehicle. Depending on the position and holding condition of the electronic key, the key may not be detected correctly and the system may not operate properly. (The

alarm may go off accidentally, or the door lock prevention function may not operate.)

■ **If the smart entry & start system does not operate properly**

- Locking and unlocking the doors: →P.408
- Starting the hybrid system: →P.408

■ **Customization**

Some functions can be customized. (→P.431)

■ **If the smart entry & start system has been deactivated in a customized setting**

- Locking and unlocking the doors: Use the wireless remote control or mechanical key. (→P.133, 408)
- Starting the hybrid system and changing power switch modes: →P.408
- Stopping the hybrid system: →P.177

■ **Certification for the smart entry & start system**

→P.487

- Users of any electrical medical device other than implantable cardiac pacemakers, cardiac resynchronization therapy-pacemakers or implantable cardioverter defibrillators should consult the manufacturer of the device for information about its operation under the influence of radio waves. Radio waves could have unexpected effects on the operation of such medical devices.

Ask any authorized Toyota retailer or Toyota authorized repairer, or any reliable repairer for details on disabling the entry function.



WARNING

■ **Caution regarding interference with electronic devices**

- People with implantable cardiac pacemakers, cardiac resynchronization therapy-pacemakers or implantable cardioverter defibrillators should maintain a reasonable distance between themselves and the smart entry & start system antennas. (→P.140)
The radio waves may affect the operation of such devices. If necessary, the entry function can be disabled. Ask any authorized Toyota retailer or Toyota authorized repairer, or any reliable repairer for details, such as the frequency of radio waves and timing of the emitted radio waves. Then, consult your doctor to see if you should disable the entry function.

Front seats

Adjustment procedure

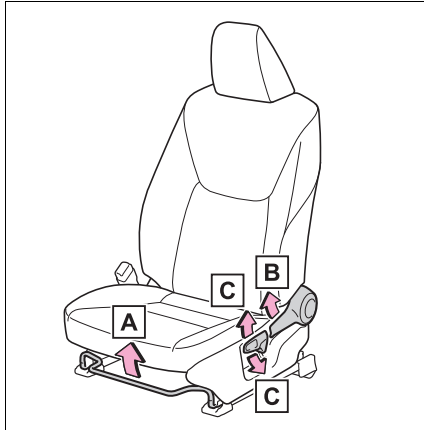

- A** Seat position adjustment lever
- B** Seatback angle adjustment lever
- C** Vertical height adjustment lever (If equipped)

⚠ WARNING

■ When adjusting the seat position

- Take care when adjusting the seat position to ensure that other passengers are not injured by the moving seat.
- Do not put your hands under the seat or near the moving parts to avoid injury. Fingers or hands may become jammed in the seat mechanism.
- Make sure to leave enough space around the feet so they do not get stuck.

■ Seat adjustment

- Be careful that the seat does not hit passengers or luggage.

- To reduce the risk of sliding under the lap belt during a collision, do not recline the seat more than necessary.

If the seat is too reclined, the lap belt may slide past the hips and apply restraint forces directly to the abdomen, or your neck may contact the shoulder belt, increasing the risk of death or serious injury in the event of an accident.

Adjustments should not be made while driving as the seat may unexpectedly move and cause the driver to lose control of the vehicle.

- After adjusting the seat, make sure that the seat is locked in position.

⚠ NOTICE

■ When adjusting a front seat

When adjusting a front seat, make sure that the head restraint does not contact the headliner. Otherwise, the head restraint and headliner may be damaged.

3

Before driving

Rear seats

The seatbacks of the rear seats can be folded down.

Folding down and returning the rear seatbacks

■ **Folding down the rear seatbacks**

- 1 Move the front seats forward. (→P.145)
- 2 Stow the rear center seat belt buckle.

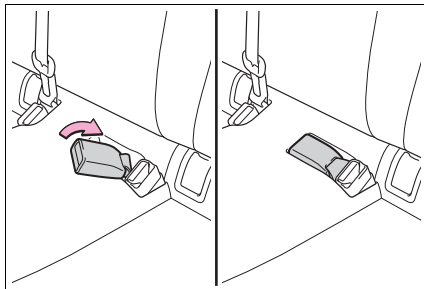

- 3 Lower the head restraints to the lowest position. (→P.148)
- 4 Pull the seatback lock release lever and fold the seatback down.

Each seatback may be folded separately.

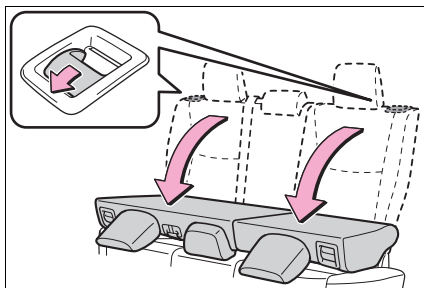

■ **Returning the rear seatbacks**

Raise the rear seatback until it locks.

Check that the seat belts are not twisted or caught in the seatback.

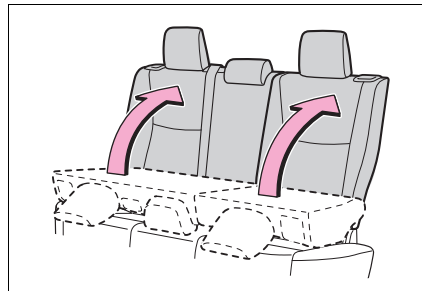

WARNING

Observe the following precautions. Failure to do so may result in death or serious injury.

■ **When folding the rear seatbacks down**

- Do not fold the seatbacks down while driving.
- Stop the vehicle on level ground, set the parking brake and shift the shift lever to P.
- Do not allow anyone to sit on a folded seatback or in the luggage compartment while driving.
- Do not allow children to enter the luggage compartment.
- Do not allow anyone to sit on the rear center seat if the rear right seat is folded down, as the seat belt buckle for the rear center seat belt is then concealed under the folded seat and cannot be used.
- Be careful not to get your hand caught when folding the rear seatbacks.

⚠ WARNING

- Adjust the position of the front seats before folding down the rear seatbacks so that the front seats do not interfere with the rear seatbacks when folding down the rear seatbacks.

- **After returning the rear seatback to the upright position**

- Make sure that the seatback is securely locked in position by lightly pushing it back and forth.

If the seatback is not securely locked, the red marking will be visible on the seatback lock release lever. Make sure that the red mark is not visible.

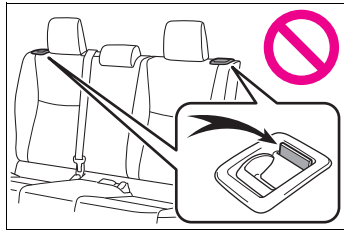

- Check that the seat belts are not twisted or caught in the seatback. If the seat belt gets caught between the seatback's securing hook and latch, it may damage the seat belt.

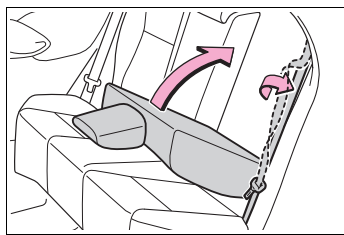
**Head restraints**

Head restraints are provided for the front seats, rear outer seats and rear center seat (if equipped).

⚠ WARNING

- **Head restraint precautions**

Observe the following precautions regarding the head restraints. Failure to do so may result in death or serious injury.

- Use the head restraints designed for each respective seat.
- Adjust the head restraints to the correct position at all times.
- After adjusting the head restraints, push down on them and make sure they are locked in position.
- Do not drive with the head restraints removed.

Adjusting a head restraint

- **Front seats**

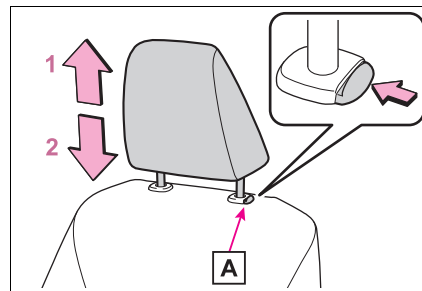

- 1 Up

Pull the head restraint up.

- 2 Down

Push the head restraint down while

pressing the lock release button **A**.

■ **Rear seats**

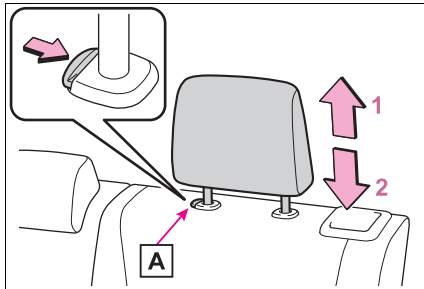

1 Up

Pull the head restraint up.

2 Down

Push the head restraint down while pressing the lock release button **A**.

■ **Adjusting the height of the head restraints (front seats)**

Make sure that the head restraints are adjusted so that the center of the head restraint is closest to the top of your ears.

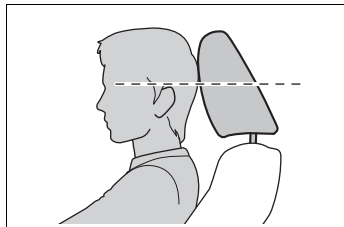

■ **Adjusting the rear center seat head restraint**

Always raise the head restraint one level from the stowed position when using.

Removing the head restraints

■ **Front seats**

Pull the head restraint up while

pressing the lock release button **A**.

If the head restraint touches the ceiling, making the removal difficult, adjust the seatback angle. (→P.145)

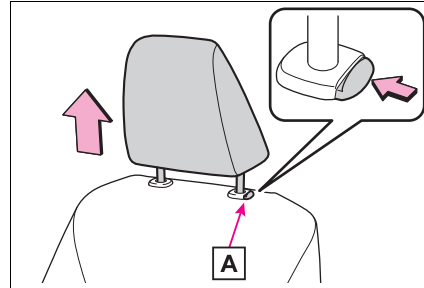

■ **Rear center seat (if equipped)**

Pull the head restraint up while pressing the lock release button **A**.

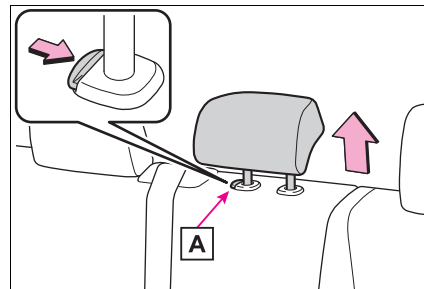

■ **Rear outer seats**

- 1** Pull the seatback lock release lever **A** and fold down the seatback until it reaches the position

where the head restraints can be removed.

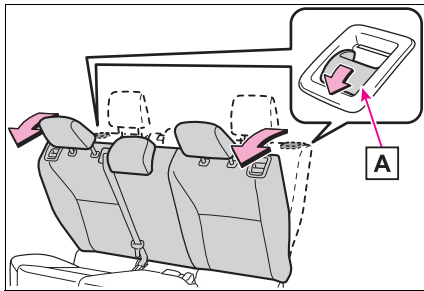

- 2 Pull the head restraint up while pressing the lock release button **B**.

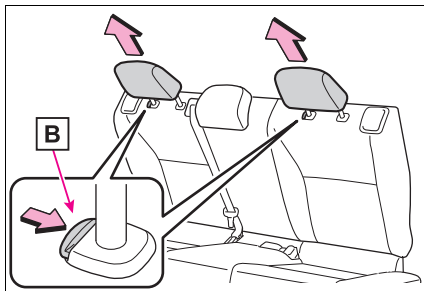

Installing the head restraints

■ **Front seats**

Align the head restraint with the installation holes and push it down to the lock position.

Press and hold the lock release button **A** when lowering the head restraint.

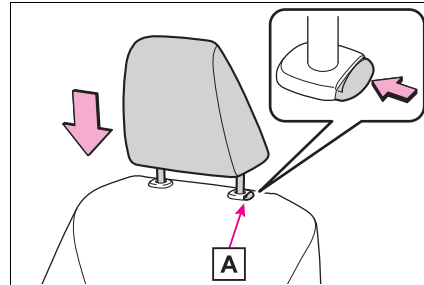

■ **Rear center seat (if equipped)**

Align the head restraint with the installation holes and push it down to the lock position.

Press and hold the lock release button **A** when lowering the head restraint.

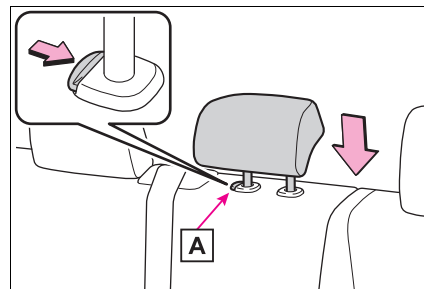

■ **Rear outer seats**

- 1 Pull the seatback lock release lever **A** and fold down the seatback until it reaches the position

3

Before driving

where the head restraints can be installed.

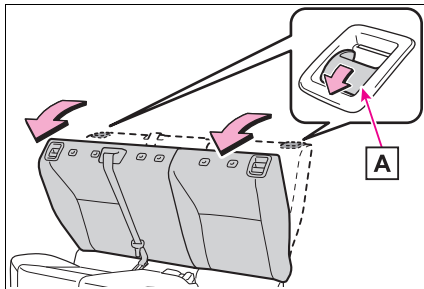

- 2** Align the head restraint with installation holes and push it down to the lock position. Press and hold the lock release button **B** when inserting the head restraint.

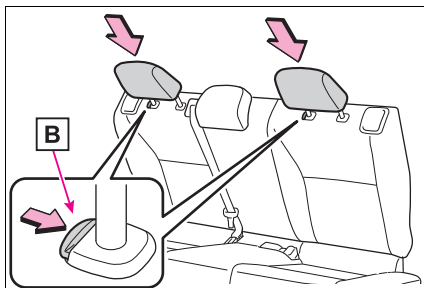

Steering wheel

Adjustment procedure

- 1 Hold the steering wheel and push the lever down.

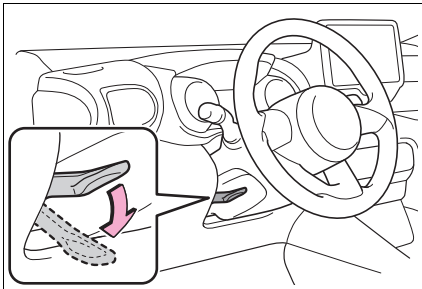

- 2 Adjust to the ideal position by moving the steering wheel horizontally and vertically.

After adjustment, pull the lever up to secure the steering wheel.

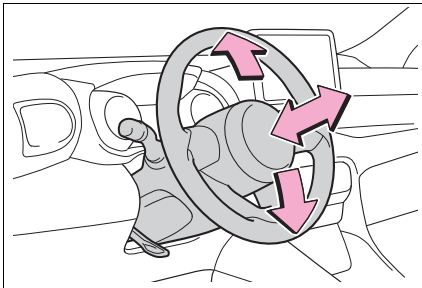

WARNING

■ Caution while driving

Do not adjust the steering wheel while driving. Doing so may cause the driver to mishandle the vehicle and cause an accident, resulting in death or serious injury.

■ After adjusting the steering wheel

Make sure that the steering wheel is securely locked. Otherwise, the steering wheel may move suddenly, possibly causing an accident, and resulting in death or serious injury. Also, the horn may not sound if the steering wheel is not securely locked.

Horn

To sound the horn, press on or close to the  mark.

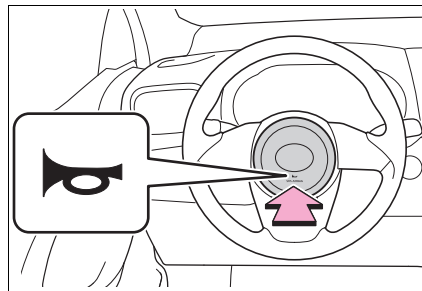

3

Before driving

Inside rear view mirror

The rear view mirror's position can be adjusted to enable sufficient confirmation of the rear view.

Adjusting the height of rear view mirror

The height of the rear view mirror can be adjusted to suit your driving posture.

Adjust the height of the rear view mirror by moving it up and down.

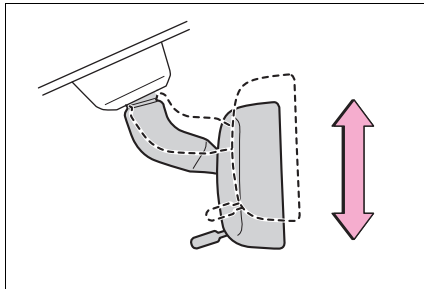

⚠ WARNING

■ Caution while driving

Do not adjust the position of the mirror while driving. Doing so may lead to mishandling of the vehicle and cause an accident, resulting in death or serious injury.

Anti-glare function

- ▶ Manual anti-glare inside rear view mirror

Reflected light from the headlights of vehicles behind can be reduced by operating the lever.

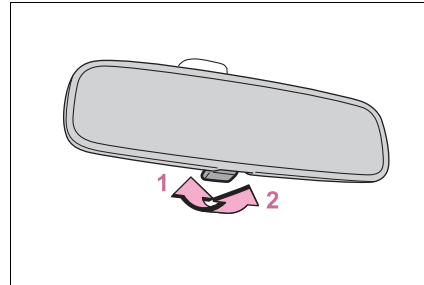

- 1 Normal position
- 2 Anti-glare position

- ▶ Auto anti-glare inside rear view mirror

Responding to the level of brightness of the headlights of vehicles behind, the reflected light is automatically reduced.

Changing automatic anti-glare function mode on/off

When the automatic anti-glare function is in ON mode, the indicator **A** illuminates. The function will set to ON mode each time the power switch is turned to ON.

Pressing the button turns the function to off mode. (The indicator **A** also turns off.)

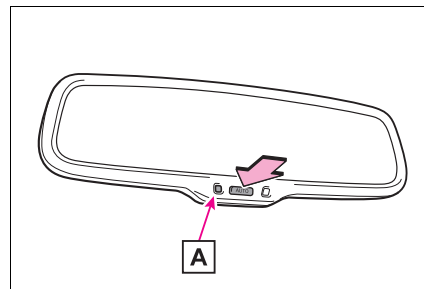

■ **To prevent sensor error (vehicles with an auto anti-glare inside rear view mirror)**

To ensure that the sensors operate properly, do not touch or cover them.

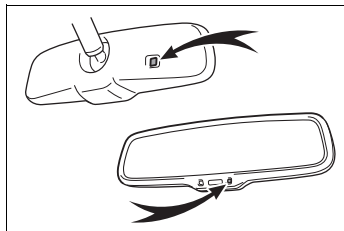

Outside rear view mirrors

The rear view mirror's position can be adjusted to enable sufficient confirmation of the rear view.

⚠ WARNING

■ Important points while driving

Observe the following precautions while driving.

Failure to do so may result in loss of control of the vehicle and cause an accident, resulting in death or serious injury.

- Do not adjust the mirrors while driving.
- Do not drive with the mirrors folded.
- Both the driver and passenger side mirrors must be extended and properly adjusted before driving.

Adjustment procedure

- 1 To select a mirror to adjust, turn the switch.

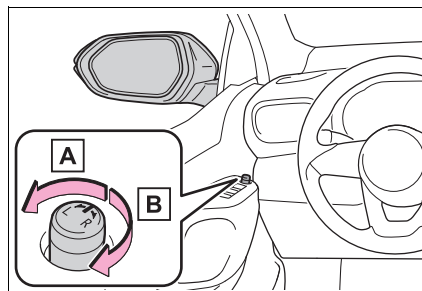

A Left

B Right

3

Before driving

2 To adjust the mirror, operate the switch.

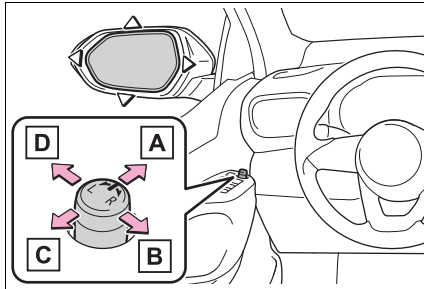

- A Up
- B Right
- C Down
- D Left

■ **Mirror angle can be adjusted when**

The power switch is in ACC or ON.

■ **When the mirrors are fogged up (if equipped)**

The outside rear view mirrors can be cleared using the mirror defoggers. Turn on the rear window defogger to turn on the outside rear view mirror defoggers. (→P.290)

WARNING

■ **When the mirror defoggers are operating (if equipped)**

Do not touch the rear view mirror surfaces, as they can become very hot and burn you.

Folding and extending the mirrors

► **Manual type**

Push the mirror back in the direction of the vehicle's rear.

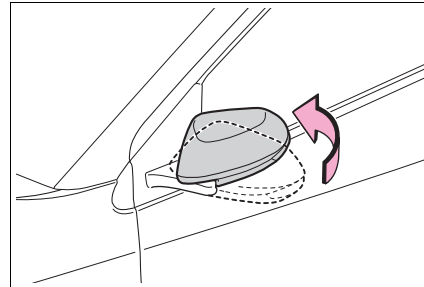

► **Power type**

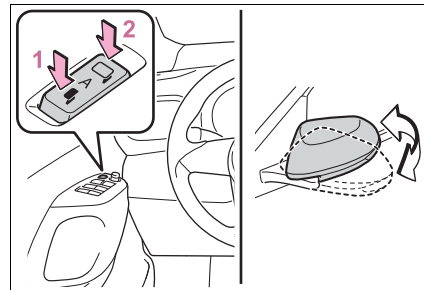

- 1 Folds the mirrors
- 2 Extends the mirrors

Putting the outside rear view mirror folding switch in the neutral position sets the mirrors to automatic mode. Automatic mode allows the folding or extending of the mirrors to be linked to locking/unlocking of the doors with the smart entry function or wireless remote control.

■ **Using automatic mode in cold weather (vehicles with automatic mode)**

When automatic mode is used in cold weather, the door mirror could freeze up and automatic stowing and return may not be possible. In this case, remove any ice and snow from the door mirror, then either operate the mirror using manual mode or move the mirror by hand.

■ **Customization**

Some functions can be customized.

(→P.431)



WARNING

■ **When a mirror is moving**

To avoid personal injury and mirror malfunction, be careful not to get your hand caught by the moving mirror.

3

Before driving

Power windows*

*: If equipped

Opening and closing the power windows

The power windows can be opened and closed using the switches. Operating the switch moves the windows as follows:

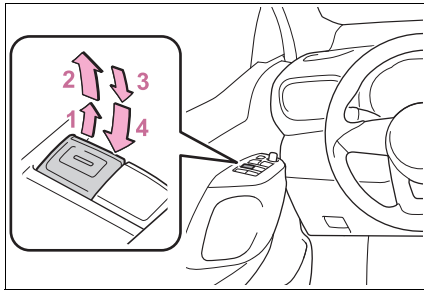

- 1 Closing
- 2 One-touch closing*
- 3 Opening
- 4 One-touch opening*

*: To stop the window partway, operate the switch in the opposite direction.

■ The power windows can be operated when

The power switch is in ON.

■ Operating the power windows after turning the hybrid system off

The power windows can be operated for approximately 45 seconds after the power switch is turned to ACC or OFF. They cannot, however, be operated once either front door is opened.

■ Jam protection function

If an object becomes jammed between the window and the window frame while

the window is closing, window movement is stopped and the window is opened slightly.

■ Catch protection function

If an object becomes caught between the door and window while the window is opening, window movement is stopped.

■ When the window cannot be opened or closed

When the jam protection function or catch protection function operates unusually and the side window cannot be opened or closed, perform the following operations with the power window switch of that door.

- Stop the vehicle. With the power switch in ON, within 4 seconds of the jam protection function or catch protection function activating, continuously operate the power window switch in the one-touch closing direction or one-touch opening direction so that the side window can be opened and closed.

- If the side window cannot be opened and closed even when performing the above operations, perform the following procedure for function initialization.

- 1 Turn the power switch to ON.
- 2 Pull and hold the power window switch in the one-touch closing direction and completely close the side window.
- 3 Release the power window switch for a moment, resume pulling the switch in the one-touch closing direction, and hold it there for approximately 6 seconds or more.
- 4 Press and hold the power window switch in the one-touch opening direction. After the side window is completely opened, continue holding the switch for an additional 1 second or more.
- 5 Release the power window switch for a moment, resume pushing the switch in the one-touch opening

direction, and hold it there for approximately 4 seconds or more.

- 6 Pull and hold the power window switch in the one-touch closing direction again. After the side window is completely closed, continue holding the switch for a further 1 second or more.

If you release the switch while the window is moving, start again from the beginning.

If the window reverses and cannot be fully closed or opened, have the vehicle inspected by any authorized Toyota retailer or Toyota authorized repairer, or any reliable repairer.

■ Door lock linked window operation

- The power windows can be opened and closed using the key (vehicles without a smart entry & start system) or mechanical key (vehicles with a smart entry & start system).* (→P.134, 408)
- The power windows can be opened and closed using the wireless remote control.* (→P.133)

*: These settings must be customized at any authorized Toyota retailer or Toyota authorized repairer, or any reliable repairer.

■ Customization

Some functions can be customized. (→P.431)



WARNING

Observe the following precautions. Failure to do so may result in death or serious injury.

■ Closing the windows

- The driver is responsible for all the power window operations, including the operation for the passengers. In order to prevent accidental operation, especially by a child, do not let a child operate the power windows. It is possible for children and other passengers to have body parts caught in the power window. Also, when riding with a child, it is recommended to use the window lock switch. (→P.158)
- Check to make sure that all passengers do not have any part of their body in a position where it could be caught when a window is being operated.

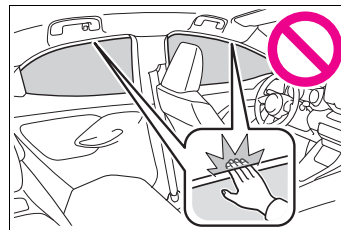

- When using the wireless remote control, key or mechanical key and operating the power windows, operate the power window after checking to make sure that there is no possibility of any passenger having any of their body parts caught in the window. Also do not let a child operate window by the wireless remote control, key or mechanical key. It is possible for children and other passengers to get caught in the power window.
- When exiting the vehicle, turn the power switch off, carry the key and exit the vehicle along with the child. There may be accidental operation, due to mischief, etc., that may possibly lead to an accident.

⚠ WARNING

■ **Jam protection function**

- Never use any part of your body to intentionally activate the jam protection function.
- The jam protection function may not work if something gets jammed just before the window is fully closed. Be careful not to get any part of your body jammed in the window.

■ **Catch protection function**

- Never use any part of your body or clothing to intentionally activate the catch protection function.
- The catch protection function may not work if something gets caught just before the window is fully opened. Be careful not to get any part of your body or clothing caught in the window.

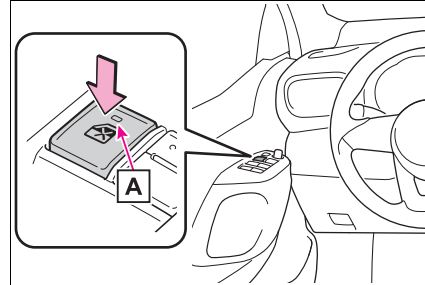

■ **The window lock switch can be operated when**

The power switch is in ON.

■ **When the 12-volt battery is disconnected**

The window lock switch is disabled. If necessary, press the window lock switch after reconnecting the 12-volt battery.

Preventing accidental operation (window lock switch)

This function can be used to prevent children from accidentally opening or closing a passenger window.

Press the switch.

The indicator **A** will come on and the passenger windows will be locked.

The passenger windows can still be opened and closed using the driver's switch even if the lock switch is on.

- 4-1. Before driving**
- Driving the vehicle **160**
 - Cargo and luggage **166**
 - Trailer towing (vehicles without towing packages - including Reunion) **167**
 - Trailer towing (vehicles with towing packages - except for Reunion) **167**
- 4-2. Driving procedures**
- Power (ignition) switch (vehicles without a smart entry & start system) **173**
 - Power (ignition) switch (vehicles with a smart entry & start system) **175**
 - EV drive mode **179**
 - Hybrid transmission **181**
 - Turn signal lever **184**
 - Parking brake **184**
 - Brake Hold **187**
- 4-3. Operating the lights and wipers**
- Headlight switch **190**
 - AHB (Automatic High Beam) **193**
 - Fog light switch **196**
 - Windshield wipers and washer **197**
 - Rear window wiper and washer **200**
- 4-4. Refueling**
- Opening the fuel tank cap. **202**
- 4-5. Using the driving support systems**
- Toyota Safety Sense **204**
 - PCS (Pre-Collision System) **209**
 - LTA (Lane Tracing Assist) . **220**
 - Dynamic radar cruise control with full-speed range **230**
 - Speed limiter **242**
 - RSA (Road Sign Assist) **244**
 - BSM (Blind Spot Monitor) . **248**
 - Toyota parking assist-sensor **253**
 - RCTA (Rear Crossing Traffic Alert) **260**
 - PKSB (Parking Support Brake) **265**
 - Parking Support Brake function (static objects) **270**
 - Parking Support Brake function (rear-crossing vehicles) .. **273**
 - Driving mode select switch **275**
 - GPF (Gasoline Particulate Filter) system **276**
 - Driving assist systems **277**
- 4-6. Driving tips**
- Hybrid vehicle driving tips. **282**
 - Winter driving tips **284**

Driving the vehicle

The following procedures should be observed to ensure safe driving:

Driving procedure

■ Starting the hybrid system

→P.173, 175

■ Driving

- 1 With the brake pedal depressed, shift the shift lever to D. (→P.181)
- 2 If the parking brake is in manual mode, release the parking brake. (→P.184)
- 3 Gradually release the brake pedal and gently depress the accelerator pedal to accelerate the vehicle.

■ Stopping

- 1 With the shift lever in D, depress the brake pedal.
- 2 If necessary, set the parking brake.

If the vehicle is to be stopped for an extended period of time, shift the shift lever to P. (→P.181)

■ Parking the vehicle

- 1 With the shift lever in D, depress the brake pedal to stop the vehicle completely.
- 2 Set the parking brake (→P.184), and shift the shift lever to P. (→P.181)

Check the parking brake indicator is illuminated.

- 3 Turn the power switch to OFF to stop the hybrid system.
- 4 Slowly release the brake pedal.
- 5 Lock the door, making sure that you have the key on your person.

If parking on a hill, block the wheels as needed.

■ Starting off on a steep uphill

- 1 Make sure that the parking brake is set and shift the shift lever to D.
- 2 Gently depress the accelerator pedal.
- 3 Release the parking brake.

■ For fuel-efficient driving

Keep in mind that hybrid vehicles are similar to conventional vehicles, and it is necessary to refrain from activities such as sudden acceleration. (→P.282)

■ Driving in the rain

- Drive carefully when it is raining, because visibility will be reduced, the windows may become fogged-up, and the road will be slippery.
- Drive carefully when it starts to rain, because the road surface will be especially slippery.
- Refrain from high speeds when driving on an expressway in the rain, because there may be a layer of water between the tires and the road surface, preventing the steering and brakes from operating properly.

■ Restraining the hybrid system output (Brake Override System)

- When the accelerator and brake pedals are depressed at the same time, the hybrid system output may be

restrained.

- A warning message is displayed on the multi-information display while the system is operating.

■ ECO Accelerator Guidance (→P.105, 111)

Eco-friendly driving may be achieved more easily by staying within the zone of Eco acceleration. Also, by staying within the zone of Eco acceleration, it will be easier to obtain a good Eco score.

- When starting off:

Gradually depress the accelerator pedal to stay within the zone of Eco acceleration and accelerate to the desired speed. By refraining from excessive acceleration, a good eco start score will be obtained.

- When driving:

After accelerating to the desired speed, release the accelerator pedal and drive at a stable speed while staying within the zone of Eco acceleration. By staying within the zone of Eco acceleration, a good eco cruise score will be obtained.

- When stopping:

By starting to release the accelerator pedal early before decelerating, a good eco stop score will be obtained.

■ Breaking in your new Toyota

To extend the life of the vehicle, observing the following precautions is recommended:

- For the first 300 km (186 miles):
Avoid sudden stops.
- For the first 800 km (500 miles):
Do not tow a trailer. (vehicles with towing packages only)
- For the first 1000 km (621 miles):
 - Do not drive at extremely high speeds.
 - Avoid sudden acceleration.
 - Do not drive at a constant speed for

extended periods.

■ Operating your vehicle in a foreign country

Comply with the relevant vehicle registration laws and confirm the availability of the correct fuel. (→P.422)

WARNING

Observe the following precautions. Failure to do so may result in death or serious injury.

■ When starting the vehicle

Always keep your foot on the brake pedal while stopped with the "READY" indicator is illuminated. This prevents the vehicle from creeping.

■ When driving the vehicle

- Do not drive if you are unfamiliar with the location of the brake and accelerator pedals to avoid depressing the wrong pedal.
- Accidentally depressing the accelerator pedal instead of the brake pedal will result in sudden acceleration that may lead to an accident.
- When backing up, you may twist your body around, leading to a difficulty in operating the pedals. Make sure to operate the pedals properly.
- Make sure to keep a correct driving posture even when moving the vehicle only slightly. This allows you to depress the brake and accelerator pedals properly.
- Depress the brake pedal using your right foot. Depressing the brake pedal using your left foot may delay response in an emergency, resulting in an accident.

**WARNING**

- The driver should pay extra attention to pedestrians when the vehicle is powered only by the electric motor (traction motor). As there is no engine noise, the pedestrians may misjudge the vehicle's movement.
- Do not drive the vehicle over or stop the vehicle near flammable materials.
The exhaust system and exhaust gases can be extremely hot. These hot parts may cause a fire if there is any flammable material nearby.
- During normal driving, do not turn off the hybrid system. Turning the hybrid system off while driving will not cause loss of steering or braking control, however, power assist to the steering will be lost. This will make it more difficult to steer smoothly, so you should pull over and stop the vehicle as soon as it is safe to do so.
In the event of an emergency, such as if it becomes impossible to stop the vehicle in the normal way:
→P.366
- Use engine braking (shift position B) to maintain a safe speed when driving down a steep hill.
Using the brakes continuously may cause the brakes to overheat and lose effectiveness. (→P.181)
- Do not adjust the positions of the steering wheel, the seat, or the inside or outside rear view mirrors while driving.
Doing so may result in a loss of vehicle control.
- Always check that all passengers' arms, heads or other parts of their body are not outside the vehicle.

■ When driving on slippery road surfaces

- Sudden braking, acceleration and steering may cause tire slippage and reduce your ability to control the vehicle.
- Sudden acceleration, engine braking due to shifting, or changes in engine speed could cause the vehicle to skid.
- After driving through a puddle, lightly depress the brake pedal to make sure that the brakes are functioning properly. Wet brake pads may prevent the brakes from functioning properly. If the brakes on only one side are wet and not functioning properly, steering control may be affected.

■ When shifting the shift lever

- Do not let the vehicle roll backward while a forward driving position is selected, or roll forward while the shift lever is in R.
Doing so may result in an accident or damage to the vehicle.
- Do not shift the shift lever to P while the vehicle is moving.
Doing so can damage the transmission and may result in a loss of vehicle control.
- Do not shift the shift lever to R while the vehicle is moving forward.
Doing so can damage the transmission and may result in a loss of vehicle control.
- Do not shift the shift lever to a driving position while the vehicle is moving backward.
Doing so can damage the transmission and may result in a loss of vehicle control.

**WARNING**

- Moving the shift lever to N while the vehicle is moving will disengage the hybrid system. Engine braking is not available with the hybrid system disengaged.

- Be careful not to shift the shift lever with the accelerator pedal depressed. Shifting the shift lever to any positions other than P or N may lead to unexpected rapid acceleration of the vehicle that may cause an accident and result in death or serious injury.

■ **If you hear a squealing or scraping noise (brake pad wear indicators)**

Have the brake pads checked and replaced by any authorized Toyota retailer or Toyota authorized repairer, or any reliable repairer as soon as possible.

Rotor damage may result if the pads are not replaced when needed.

It is dangerous to drive the vehicle when the wear limits of the brake pads and/or those of the brake discs are exceeded.

■ **When the vehicle is stopped**

- Do not depress the accelerator pedal unnecessarily.
If the shift lever is any position other than P or N, the vehicle may accelerate suddenly and unexpectedly, causing an accident.
- In order to prevent accidents due to the vehicle rolling away, always keep depressing the brake pedal while stopped with the "READY" indicator is illuminated, and apply the parking brake as necessary.

- If the vehicle is stopped on an incline, in order to prevent accidents caused by the vehicle rolling forward or backward, always depress the brake pedal and securely apply the parking brake as needed.

- Avoid revving or racing the engine. Running the engine at high speed while the vehicle is stopped may cause the exhaust system to overheat, which could result in a fire if combustible material is nearby.

■ **When the vehicle is parked**

- Do not leave glasses, cigarette lighters, spray cans, or soft drink cans in the vehicle when it is in the sun.
Doing so may result in the following:

- Gas may leak from a cigarette lighter or spray can, and may lead to a fire.
- The temperature inside the vehicle may cause the plastic lenses and plastic material of glasses to deform or crack.
- Soft drink cans may fracture, causing the contents to spray over the interior of the vehicle, and may also cause a short circuit in the vehicle's electrical components.

- Do not leave cigarette lighters in the vehicle. If a cigarette lighter is in a place such as the glove box or on the floor, it may be lit accidentally when luggage is loaded or the seat is adjusted, causing a fire.

- Do not attach adhesive discs to the windshield or windows. Do not place containers such as air fresheners on the instrument panel or dashboard. Adhesive discs or containers may act as lenses, causing a fire in the vehicle.

**WARNING**

- Do not leave a door or window open if the curved glass is coated with a metallized film such as a silver-colored one. Reflected sunlight may cause the glass to act as a lens, causing a fire.
- Always apply the parking brake, shift the shift lever to P, stop the hybrid system and lock the vehicle. Do not leave the vehicle unattended while the hybrid system is operating.
If the vehicle is parked with the shift lever in P but the parking brake is not set, the vehicle may start to move, possibly leading to an accident.
- Do not touch the exhaust pipes while the "READY" indicator is illuminated or immediately after turning the hybrid system off. Doing so may cause burns.

■ When taking a nap in the vehicle

Always turn the hybrid system off. Otherwise, if you accidentally move the shift lever or depress the accelerator pedal, this could cause an accident or fire due to hybrid system overheating. Additionally, if the vehicle is parked in a poorly ventilated area, exhaust gases may collect and enter the vehicle, leading to death or a serious health hazard.

■ When braking

- When the brakes are wet, drive more cautiously.
Braking distance increases when the brakes are wet, and this may cause one side of the vehicle to brake differently than the other side. Also, the parking brake may not securely hold the vehicle.

- If the electronically controlled brake system does not operate, do not follow other vehicles closely and avoid hills or sharp turns that require braking.

In this case, braking is still possible, but the brake pedal should be depressed more firmly than usual. Also, the braking distance will increase. Have your brakes fixed immediately.

- The brake system consists of 2 or more individual hydraulic systems; if one of the systems fails, the other(s) will still operate. In this case, the brake pedal should be depressed more firmly than usual and the braking distance will increase. Have your brakes fixed immediately.

■ If the vehicle becomes stuck

Do not spin the wheels excessively when a driven wheel is up in the air, or the vehicle is stuck in sand, mud, etc. This may damage the driveline components or propel the vehicle forward or backward, causing an accident.

**NOTICE****■ When driving the vehicle**

- Do not depress the accelerator and brake pedals at the same time during driving, as this may restrain the hybrid system output.
- Do not use the accelerator pedal or depress the accelerator and brake pedals at the same time to hold the vehicle on a hill.

■ When parking the vehicle

Always set the parking brake and shift the shift lever to P. Failure to do so may cause the vehicle to move or the vehicle may accelerate suddenly if the accelerator pedal is accidentally depressed.



NOTICE

■ Avoiding damage to vehicle parts

- Do not turn the steering wheel fully in either direction and hold it there for an extended period of time. Doing so may damage the power steering motor.
- When driving over bumps in the road, drive as slowly as possible to avoid damaging the wheels, underside of the vehicle, etc.

■ If you get a flat tire while driving

A flat or damaged tire may cause the following situations. Hold the steering wheel firmly and gradually depress the brake pedal to slow down the vehicle.

- It may be difficult to control your vehicle.
- The vehicle will make abnormal sounds or vibrations.
- The vehicle will lean abnormally.

Information on what to do in case of a flat tire (→P.386, 397)

■ When encountering flooded roads

Do not drive on a road that has flooded after heavy rain, etc. Doing so may cause the following serious damage to the vehicle:

- Engine stalling
- Short in electrical components
- Engine damage caused by water immersion

In the event that you drive on a flooded road and the vehicle becomes flooded or stuck in mud or sand, be sure to have any authorized Toyota retailer or Toyota authorized repairer, or any reliable repairer check the following:

- Brake function

- Changes in quantity and quality of oil and fluid used for the engine, hybrid transmission, etc.

- Lubricant condition for the bearings and suspension joints (where possible), and the function of all joints, bearings, etc.

Sudden start restraint control (Drive-Start Control [DSC])

When the following unusual operation is performed with the accelerator pedal depressed, the hybrid system output may be restrained.

- When the shift lever is shifted to R*.
- When the shift lever is shifted from P or R to forward drive shift position such as D*.

When the system operates, a message appears on the multi-information display. Read the message and follow the instruction.

* : Depending on the situation, the shift position may not be changed.

■ Drive-Start Control (DSC)

When the TRC is turned off (→P.278), sudden start restraint control also does not operate. If your vehicle have trouble escaping from the mud or fresh snow due to sudden start restraint control operation, deactivate TRC (→P.278) so that the vehicle may become able to escape from the mud or fresh snow.

Cargo and luggage

Take notice of the following information about storage precautions, cargo capacity and load:



WARNING

■ Things that must not be carried in the luggage compartment

The following things may cause a fire if loaded in the luggage compartment:

- Receptacles containing gasoline
- Aerosol cans

■ Storage precautions

Observe the following precautions. Failure to do so may prevent the pedals from being depressed properly, may block the driver's vision, or may result in items hitting the driver or passengers, possibly causing an accident.

- Stow cargo and luggage in the luggage compartment whenever possible.
- Do not stack cargo and luggage in the luggage compartment higher than the seatbacks.
- When you fold down the rear seats, long items should not be placed directly behind the front seats.
- Do not place cargo or luggage in or on the following locations.
 - At the feet of the driver
 - On the front passenger or rear seats (when stacking items)
 - On the luggage cover
 - On the instrument panel
 - On the dashboard

- Secure all items in the occupant compartment.

- Never allow anyone to ride in the luggage compartment. It is not designed for passengers. They should ride in their seats with their seat belts properly fastened.

■ Load and distribution

- Do not overload your vehicle.
- Do not apply loads unevenly. Improper loading may cause deterioration of steering or braking control which may cause death or serious injury.

Trailer towing (vehicles without towing packages - including Reunion)

Toyota does not recommend towing a trailer with your vehicle.

Toyota also does not recommend the installation of a tow hitch or the use of a tow hitch carrier for a wheelchair, scooter, bicycle, etc. Your vehicle is not designed for trailer towing or for the use of tow hitch mounted carriers.

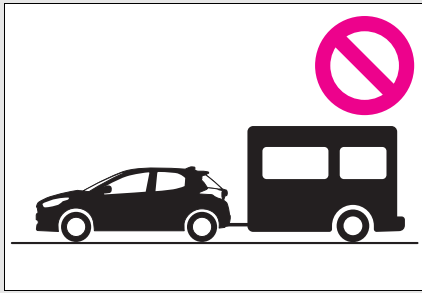
**Trailer towing (vehicles with towing packages - except for Reunion)**

Your vehicle is designed primarily as a passenger carrying vehicle. Towing a trailer will have an adverse effect on handling, performance, braking, durability, and fuel consumption. Your safety and satisfaction depend on the proper use of correct equipment and cautious driving habits. For your safety and the safety of others, do not overload the vehicle or trailer.

To tow a trailer safely, use extreme care and drive the vehicle in accordance with the trailer's characteristics and operating conditions.

Toyota warranties do not apply to damage or malfunction caused by towing a trailer for commercial purposes.

Contact any authorized Toyota retailer or Toyota authorized repairer, or any reliable repairer for further information about additional requirements such as towing kits, etc.

Weight limits

Check the allowable towing capacity, GVM (Gross Vehicle Mass), MPAC (Maximum Permissible Axle

Capacity), and permissible drawbar load before towing. (→P.420)

Towing hitch/bracket

Toyota recommends the use of the Toyota hitch/bracket for your vehicle. Other products of a suitable nature and comparable quality may also be used.

For vehicles where the towing device blocks any of the lights or license plate, the following shall be observed:

- Do not use towing devices that cannot be easily removed or repositioned.
- Towing devices must be removed or repositioned when not in use.

Important points regarding trailer loads

Total trailer weight and permissible drawbar load

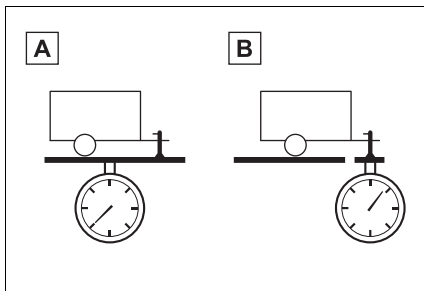

A Total trailer weight
Weight of the trailer itself plus the trailer load should be within the maximum towing capacity. Exceeding this weight

is dangerous. (→P.420)

When towing a trailer, use a friction coupler or friction stabilizer (sway control device).

B Permissible drawbar load

Allocate the trailer load so that the drawbar load is greater than 25 kg (55.1 lb.) or 4% of the towing capacity. Do not let the drawbar load exceed the indicated weight. (→P.420)

Information tag (manufacturer's label)

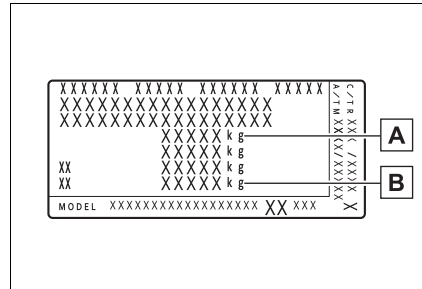

A Gross vehicle mass

The combined weight of the driver, passengers, luggage, towing hitch, total curb mass and drawbar load should not exceed the gross vehicle mass by more than 100 kg (220.5 lb.). Exceeding this weight is dangerous.

B Maximum permissible rear axle capacity

The weight borne by the rear axle should not exceed the maximum permissible rear axle capacity by 15% or more. Exceeding this weight is dangerous. The values for towing capacity were derived from testing conducted at sea level. Take note that engine output and towing capacity will be reduced at high altitudes.

⚠ WARNING

■ **When the gross vehicle mass or maximum permissible axle capacity is exceeded**

Failing to observe this precaution may lead to an accident causing death or serious injury.

- Add an additional 20.0 kPa (0.2 kgf/cm² or bar, 3 psi) to the recommended tire inflation pressure value. (→P.427)
- Do not exceed the established speed limit for towing a trailer in built-up areas or 100 km/h (62 mph), whichever is lower.

Installation positions for the towing hitch/bracket and hitch ball

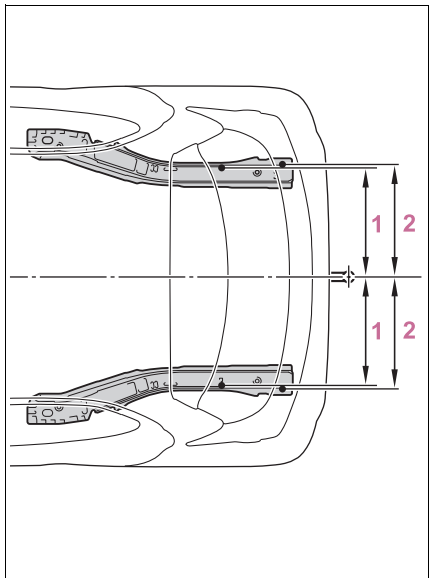

- 1** 511 mm (20.1 in.)
- 2** 513 mm (20.2 in.)

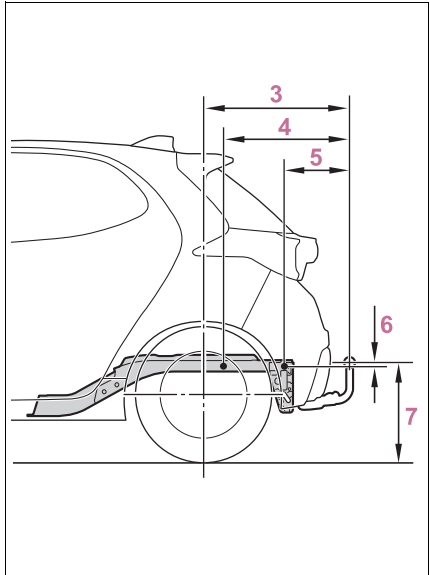

- 3** 690 mm (27.2 in.)
- 4** 600 mm (23.6 in.)
- 5** 322 mm (12.7 in.)
- 6** 19 mm (0.75 in.)
- 7** 370 mm (14.6 in.)

■ **Tire information**

- Increase the tire inflation pressure to 20.0 kPa (0.2 kgf/cm² or bar, 3 psi) greater than the recommended value when towing. (→P.427)
- Increase the air pressure of the trailer tires in accordance with the total trailer weight and according to the values recommended by the manufacturer of your trailer.

■ **Trailer lights**

Please consult any authorized Toyota retailer or Toyota authorized repairer, or any reliable repairer when installing trailer lights, as incorrect installation may cause damage to the vehicle's lights. Please take care to comply with your state's laws when installing trailer lights.

■ **Break-in schedule**

Toyota recommends that vehicles fitted with new power train components should not be used for towing trailers for the first 800 km (500 miles).

■ **Safety checks before towing**

- Check that the maximum load limit for the towing hitch/bracket hitch ball is not exceeded. Bear in mind that the coupling weight of the trailer will add to the load exerted on the vehicle. Also make sure that you will not be towing a load that exceeds the maximum permissible axle capacity.
- Ensure that the trailer load is secure.
- Supplementary outside rear view mirrors should be added to the vehicle if the traffic behind cannot be clearly seen with standard mirrors. Adjust the extending arms of these mirrors on both sides of the vehicle so that they always provide maximum visibility of the road behind.

■ **Maintenance**

- Maintenance must be performed more frequently when using the vehicle for towing due to the greater weight burden placed on the vehicle compared to normal driving.
- Retighten all bolts securing the hitching ball and bracket after towing for approximately 1000 km (600 miles).

	<p>NOTICE</p>
<p>■ When the rear bumper strengthening material is aluminum</p> <p>Ensure the steel bracket part does not come directly in contact with that area.</p> <p>When steel and aluminum come into contact, there is a reaction similar to corrosion, which will weaken the section concerned and may result in damage. Apply a rust inhibitor to parts that will come in contact when attaching a steel bracket.</p>	

Guidance

Your vehicle will handle differently when towing a trailer. In order to avoid accident, death or serious injury, keep the following in mind when towing:

■ **Checking connections between trailer and lights**

Stop the vehicle and check the operation of the connection between the trailer and lights after driving for a brief period as well as before starting off.

■ **Practicing driving with a coupled trailer**

- Get the feel for turning, stopping and reversing with the trailer coupled by practicing in an area with no or light traffic.
- When reversing with a coupled trailer, hold the section of the steering wheel nearest to you and rotate clockwise to turn the trailer left or counterclockwise to turn it right. Always rotate a little at a time to prevent steering error. Have someone guide you when reversing to lessen the risk of an accident.

■ **Increasing vehicle-to-vehicle distance**

At a speed of 10 km/h (6 mph), the distance to the vehicle running ahead of you should be equivalent to or greater than the combined length of your vehicle and trailer.

Avoid sudden braking that may cause skidding. Otherwise, the vehicle may spin out of control. This is especially true when driving on wet or slippery road surfaces.

■ Sudden acceleration/steering input/cornering

Executing sharp turns when towing may result in the trailer colliding with your vehicle. Decelerate well in advance when approaching turns and take them slowly and carefully to avoid sudden braking.

■ Important points regarding turning

The wheels of the trailer will travel closer to the inside of the curve than the wheels of the vehicle. To make allowance for this, take the turns wider than you would normally do.

■ Important points regarding stability

Vehicle movement resulting from uneven road surfaces and strong crosswinds will affect handling. The vehicle may also be rocked by passing buses or large trucks. Frequently check behind when moving alongside such vehicles. As soon as such vehicle movement occurs, immediately start to decelerate smoothly by slowly applying the brakes. Always steer the vehicle straight ahead while braking.

■ Passing other vehicles

Consider the total combined length

of your vehicle and trailer and ensure that the vehicle-to-vehicle distance is sufficient before executing lane changes.

■ Transmission information

To maintain engine braking efficiency and charging system performance when using engine braking, do not use the transmission in D. (→P.181)

■ If the engine overheats

Towing a loaded trailer up a long, steep incline in temperatures exceeding 30°C (85°F) may result in the engine overheating. If the engine coolant temperature gauge indicates that the engine is overheating, turn the air conditioning off immediately, leave the road and stop the vehicle in a safe place. (→P.414)

■ When parking the vehicle

Always place wheel chocks under the wheels of both the vehicle and trailer. Firmly set the parking brake and shift the shift lever to P.

WARNING

Follow all the instructions described in this section. Failure to do so could cause an accident resulting in death or serious injury.

■ Trailer towing precautions

When towing, make sure that none of the weight limits are exceeded. (→P.168)

**WARNING****■ Vehicle speed in towing**

Observe the legal maximum speeds for trailer towing.

■ Before descending hills or long declines

Reduce speed and downshift. However, never downshift suddenly while descending steep or long downhill grades.

■ Operation of the brake pedal

Do not hold the brake pedal depressed often or for long periods of time. Doing so may result in the brake overheating or reduce braking effects.

■ To avoid accident or injury

- Vehicles with a compact spare tire: Do not tow a trailer when the compact spare tire is installed on your vehicle.
- Vehicles with the emergency tire puncture repair kit: Do not tow a trailer when the tire installed is repaired with the emergency tire puncture repair kit.
- Vehicles with a Dynamic radar cruise control: Do not use dynamic radar cruise control when you are towing.

**NOTICE****■ Do not directly splice trailer lights**

Directly splicing trailer lights may damage your vehicle's electrical system and cause a malfunction.

Power (ignition) switch (vehicles without a smart entry & start sys- tem)

Starting the hybrid system

- 1 Pull the parking brake switch to check that the parking brake is set.
- 2 Check that the shift lever is set in P.
- 3 Firmly depress the brake pedal.
- 4 Turn the power switch to START to start the hybrid system.

If the "READY" indicator turns on, the hybrid system will operate normally.

Continue depressing the brake pedal until the "READY" indicator is illuminated.

- 5 Check that the "READY" indicator is illuminated.

The vehicle cannot be driven if the "READY" indicator is off.

■ If the hybrid system does not start

The immobilizer system may not have been deactivated. (→P.84) Contact any authorized Toyota retailer or Toyota authorized repairer, or any reliable repairer.

■ When the ambient temperature is low, such as during winter driving conditions

- When starting the hybrid system, the flashing time of the "READY" indicator may be long. Leave the vehicle as it is until the "READY" indicator is steady on, as steady means the vehicle is able to move.
- When the hybrid battery (traction battery) is extremely cold (below approxi-

mately -30°C [-22°F]) under the influence of the outside temperature, it may not be possible to start the hybrid system. In this case, try to start the hybrid system again after the temperature of the hybrid battery increases due to the outside temperature increase, etc.

■ Sounds and vibrations specific to a hybrid vehicle

→P.78

■ When the steering lock cannot be released

When starting the hybrid system, the power switch may seem stuck in OFF. To free it, turn the key while turning the steering wheel slightly left and right.

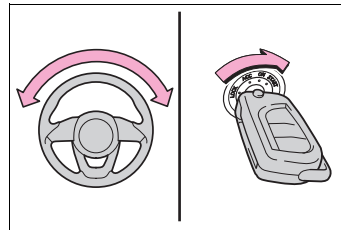

■ If the "READY" indicator does not come on

In the event that the "READY" indicator does not come on even after performing the proper procedures for starting the vehicle, contact any authorized Toyota retailer or Toyota authorized repairer, or any reliable repairer immediately.

■ If the hybrid system is malfunctioning

→P.383

⚠ WARNING

■ When starting the hybrid system

Always start the hybrid system while sitting in the driver's seat. Do not depress the accelerator pedal while starting the hybrid system under any circumstances. Doing so may cause an accident resulting in death or serious injury.

 NOTICE

■ **When starting the hybrid system**

If the hybrid system becomes difficult to start, have your vehicle checked by any authorized Toyota retailer or Toyota authorized repairer, or any reliable repairer immediately.

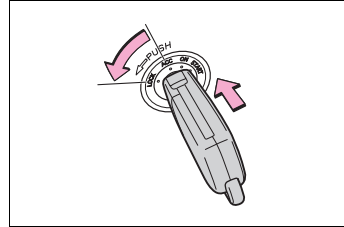

Changing the power switch positions

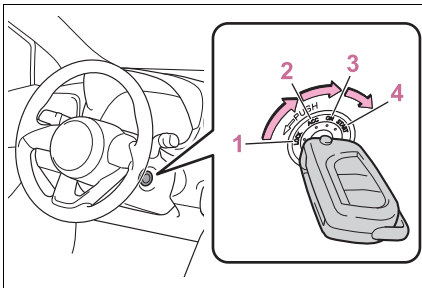

1 OFF ("LOCK" position)

The steering wheel is locked and the key can be removed. (The key can be removed only when the shift lever is in P.)

2 ACC ("ACC" position)

Some electrical components such as the audio system can be used.

3 ON ("ON" position)

All electrical components can be used.

4 START ("START" position)

For starting the hybrid system.

■ **Turning the key from ACC to OFF**

- 1 Shift the shift lever to P.
- 2 Push in the key and turn it to OFF.

■ **Key reminder function**

A buzzer sounds if the driver's door is opened while the power switch is in OFF or ACC to remind you to remove the key.

 **WARNING**

■ **Caution when driving**

Do not turn the power switch to OFF while driving. If, in an emergency, you must turn the hybrid system off while the vehicle is moving, turn the power switch only to ACC to stop the hybrid system. An accident may result if the hybrid system is stopped while driving. (→P.366)

 NOTICE

■ **To prevent 12-volt battery discharge**

Do not leave the power switch in ACC or ON for long periods of time without the hybrid system running.

Power (ignition) switch (vehicles with a smart entry & start system)

Performing the following operations when carrying the electronic key on your person starts the hybrid system or changes power switch modes.

Starting the hybrid system

- 1 Pull the parking brake switch to check that the parking brake is set.
- 2 Check that the shift lever is in P.
- 3 Firmly depress the brake pedal.

 and a message will be displayed on the multi-information display. If it is not displayed, the hybrid system cannot be started.

- 4 Press the power switch shortly and firmly.

When operating the power switch, one short, firm press is enough. It is not necessary to press and hold the switch. If the "READY" indicator turns on, the hybrid system will operate normally.

Continue depressing the brake pedal until the "READY" indicator is illuminated.

The hybrid system can be started from

any power switch mode.

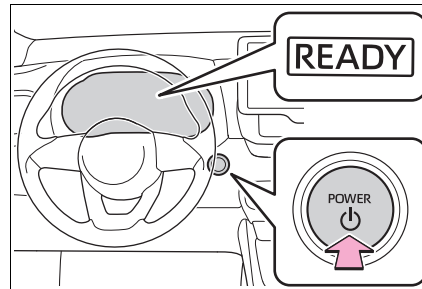

- 5 Check that the "READY" indicator is illuminated.

The vehicle cannot be driven if the "READY" indicator is off.

Power switch illumination

In the following situations, the power switch is illuminated.

- When the driver's or passenger's door is opened.
- When the power switch is in ACC or ON.
- When the power switch mode is changed from ACC or ON to off.

Also, in the following situation, the power switch flashes.

- When depressing the brake pedal while carrying the electronic key.

If the hybrid system does not start

- The immobilizer system may not have been deactivated. (→P.84)
Contact any authorized Toyota retailer or Toyota authorized repairer, or any reliable repairer.
- If a message related to start-up is shown on the multi-information display, read the message and follow the instructions.

When the ambient temperature is low, such as during winter driving conditions

- When starting the hybrid system, the flashing time of the "READY" indicator may be long. Leave the vehicle as it is

until the “READY” indicator is steady on, as steady means the vehicle is able to move.

- When the hybrid battery (traction battery) is extremely cold (below approximately -30°C [-22°F]) under the influence of the outside temperature, it may not be possible to start the hybrid system. In this case, try to start the hybrid system again after the temperature of the hybrid battery increases due to the outside temperature increase, etc.

■ Sounds and vibrations specific to a hybrid vehicle

→P.78

■ If the 12-volt battery is discharged

The hybrid system cannot be started using the smart entry & start system. Refer to P.409 to restart the hybrid system.

■ Electronic key battery depletion

→P.129

■ Conditions affecting operation

→P.142

■ Notes for the entry function

→P.142

■ Steering lock function

- After turning the power switch off and opening and closing the doors, the steering wheel will be locked due to the steering lock function. Operating the power switch again automatically cancels the steering lock.
- When the steering lock cannot be released, “Push Power Switch while Turning Steering Wheel in Either Direction” will be displayed on the multi-information display. Press the power switch shortly and firmly while turning the steering wheel left and right.

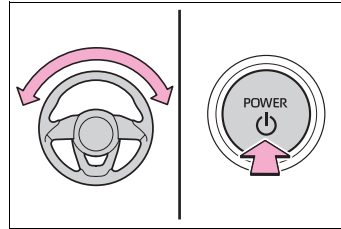

- To prevent the steering lock motor from overheating, the motor may be suspended if the hybrid system is turned on and off repeatedly in a short period of time. In this case, refrain from operating the power switch. After about 10 seconds, the steering lock motor will resume functioning.

■ If the “READY” indicator does not come on

In the event that the “READY” indicator does not come on even after performing the proper procedures for starting the vehicle, contact any authorized Toyota retailer or Toyota authorized repairer, or any reliable repairer immediately.

■ If the hybrid system is malfunctioning

→P.383

■ Electronic key battery

→P.351

■ Operation of the power switch

- If the switch is not pressed shortly and firmly, the power switch mode may not change or the hybrid system may not start.
- If attempting to restart the hybrid system immediately after turning the power switch off, the hybrid system may not start in some cases. After turning the power switch off, please wait a few seconds before restarting the hybrid system.

■ Customization

If the smart entry & start system has been deactivated in a customized setting, refer to P.407.

⚠ WARNING**■ When starting the hybrid system**

Always start the hybrid system while sitting in the driver's seat. Do not depress the accelerator pedal while starting the hybrid system under any circumstances.

Doing so may cause an accident resulting in death or serious injury.

■ Caution while driving

If hybrid system failure occurs while the vehicle is moving, do not lock or open the doors until the vehicle reaches a safe and complete stop. Activation of the steering lock in this circumstance may lead to an accident, resulting in death or serious injury.

⚠ NOTICE**■ When starting the hybrid system**

If the hybrid system becomes difficult to start, have your vehicle checked by any authorized Toyota retailer or Toyota authorized repairer, or any reliable repairer immediately.

■ Symptoms indicating a malfunction with the power switch

If the power switch seems to be operating somewhat differently than usual, such as the switch sticking slightly, there may be a malfunction. Contact any authorized Toyota retailer or Toyota authorized repairer, or any reliable repairer immediately.

Stopping the hybrid system

- 1 Stop the vehicle completely.
- 2 Set the parking brake (→P.184), and shift the shift lever to P.

Check the parking brake indicator is illuminated.

- 3 Press the power switch.

The hybrid system will stop, and the meter display will be extinguished.

- 4 Release the brake pedal and check that "ACCESSORY" or "IGNITION ON" is not shown on the multi-information display.

⚠ WARNING**■ Stopping the hybrid system in an emergency**

- If you want to stop the hybrid system in an emergency while driving the vehicle, press and hold the power switch for more than 2 seconds, or press it briefly 3 times or more in succession. (→P.366) However, do not touch the power switch while driving except in an emergency. Turning the hybrid system off while driving will not cause loss of steering or braking control, however, power assist to the steering will be lost. This will make it more difficult to steer smoothly, so you should pull over and stop the vehicle as soon as it is safe to do so.
- If the power switch is operated while the vehicle is running, a warning message will be shown on the multi-information display and a buzzer sounds.
- To restart the hybrid system after performing an emergency shut-down, shift the shift lever to N and then press the power switch.

Changing power switch modes

Modes can be changed by pressing the power switch with brake pedal released. (The mode changes each time the switch is pressed.)

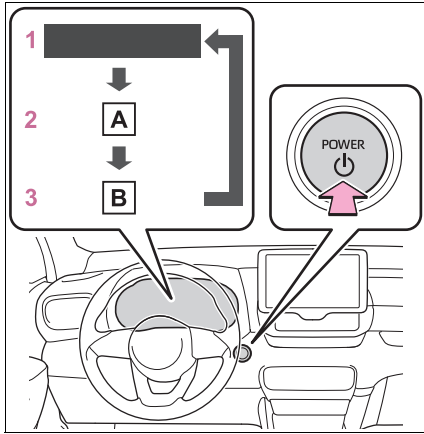

A "ACCESSORY"

B "IGNITION ON"

1 OFF*

The emergency flashers can be used.

2 ACC

Some electrical components such as the audio system can be used.

"ACCESSORY" will be displayed on the multi-information display.

3 ON

All electrical components can be used.

"IGNITION ON" will be displayed on the multi-information display.

*: If the shift lever is in a position other than P when turning off the hybrid system, the power switch will be remained to ON, not to off.

■ Auto power off function

If the vehicle is left in ACC or ON (the hybrid system is not operating) for more than 20 minutes with the shift lever in P, the power switch will automatically turn off. However, this function cannot entirely prevent 12-volt battery discharge. Do not leave the vehicle with the power switch in ACC or ON for long periods of time when the hybrid system

is not operating.

⚠ NOTICE

■ To prevent 12-volt battery discharge

- Do not leave the power switch in ACC or ON for long periods of time without the hybrid system on.
- If "ACCESSORY" or "IGNITION ON" is displayed on the multi-information display, the power switch is not off. Exit the vehicle after turning the power switch off.

When stopping the hybrid system with the shift lever in a position other than P

If the hybrid system is stopped with the shift lever in a position other than P, the power switch will not be turned off. Perform the following procedure to turn the switch off:

- 1** Check that the parking brake is set.
- 2** Shift the shift lever to P.
- 3** Check that "IGNITION ON" is displayed on the multi-information display and press the power switch shortly and firmly.
- 4** Check that "ACCESSORY" or "IGNITION ON" on the multi-information display is off.



NOTICE

■ To prevent 12-volt battery discharge

Do not stop the hybrid system when the shift lever is in a position other than P. If the hybrid system is stopped in another shift lever position, the power switch will not be turned off and remained to ON. If the vehicle is left in ON, battery discharge may occur.

EV drive mode

In EV drive mode, electric power is supplied by the hybrid battery (traction battery), and only the electric motor (traction motor) is used to drive the vehicle.

This mode allows you to drive in residential areas early in the morning and late at night, or in indoor parking lots, etc., without concern for noises and gas emissions.

Operating instructions

Turns EV drive mode on/off

When EV drive mode is turned on, the EV drive mode indicator will come on. Pressing the switch when in EV drive mode will return the vehicle to normal driving (using the gasoline engine and electric motor [traction motor]).

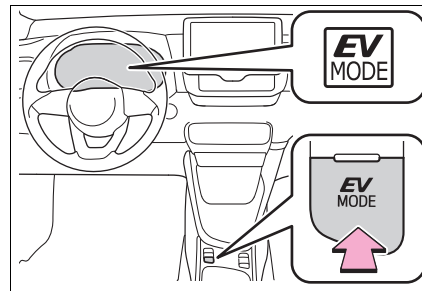
**■ Situations in which EV drive mode cannot be turned on**

It may not be possible to turn EV drive mode on in the following situations. If it cannot be turned on, a buzzer will sound and a message will be shown on the multi-information display.

- The temperature of the hybrid system is high.
The vehicle has been left in the sun, driven on a hill, driven at high speeds, etc.
- The temperature of the hybrid system is low.
The vehicle has been left in temperatures lower than about 0°C (32°F) for a long period of time, etc.
- The gasoline engine is warming up.
- The hybrid battery (traction battery) is low.
The remaining battery level indicated in the energy monitor display is low. (→P.120)
- Vehicle speed is high.
- The accelerator pedal is depressed firmly or the vehicle is on a hill, etc.
- The windshield defogger is in use.

■ **Switching to EV drive mode when the gasoline engine is cold**

If the hybrid system is started while the gasoline engine is cold, the gasoline engine will start automatically after a short period of time in order to warm up. In this case, you will become unable to switch to EV drive mode.

After the hybrid system has started and the “READY” indicator has illuminated, press the EV drive mode switch before the gasoline engine starts to switch to EV drive mode.

■ **Automatic cancelation of EV drive mode**

When driving in EV drive mode, the gasoline engine may start automatically and the vehicle may be driven by the gasoline engine and electric motor (traction motor) in the following situations. When EV drive mode is canceled, a buzzer will sound, the EV drive mode indicator will flash, and a message will be displayed on the multi-information display.

- The hybrid battery (traction battery) becomes low.
The remaining battery level indicated in the energy monitor display is low.

(→P.120)

- Vehicle speed is high.
- The accelerator pedal is depressed firmly or the vehicle is on a hill, etc.

■ **Possible driving distance when driving in EV drive mode**

EV drive mode’s possible driving distance ranges from a few hundred meters to approximately 1 km (0.6 mile). However, depending on vehicle conditions, there are situations when EV drive mode cannot be used.

(The distance that is possible depends on the hybrid battery [traction battery] level and driving conditions.)

■ **Fuel economy**

The hybrid system is designed to achieve the best possible fuel economy during normal driving (using the gasoline engine and electric motor [traction motor]). Driving in EV drive mode more than necessary may lower fuel economy.

■ **If “EV Mode Unavailable” is shown on the multi-information display**

The EV drive mode is not available. The reason the EV drive mode is not available (the vehicle is idling, battery charge is low, vehicle speed is higher than the EV drive mode operating speed range or accelerator pedal is depressed too much) may be displayed. Use the EV drive mode when it becomes available.

■ **If “EV Mode Deactivated” is shown on the multi-information display**

The EV drive mode has been automatically canceled. The reason the EV drive mode is not available (the battery charge is low, vehicle speed is higher than the EV drive mode operating speed range or accelerator pedal is depressed too much) may be displayed. Drive the vehicle for a while before attempting to turn on the EV drive mode again.

**WARNING****■ Caution while driving**

When driving in EV drive mode, pay special attention to the area around the vehicle. Because there is no engine noise, pedestrians, people riding bicycles or other people and vehicles in the area may not be aware of the vehicle starting off or approaching them.

Take extra care while driving even if the acoustic vehicle alerting system is active.

Hybrid transmission

Select the shift position depending on your purpose and situation.

Shift position purpose and functions

Shift position	Objective or function
P	Parking the vehicle/starting the hybrid system
R	Reversing
N	Neutral (Condition in which the power is not transmitted)
D	Normal driving*
B	Applying moderate engine braking driving down hills

*: To improve fuel efficiency and reduce noise, shift the shift lever to D for normal driving.

■ Restraining sudden start (Drive-Start Control)

→P.165

■ When driving with dynamic radar cruise control with full-speed range activated

Even when switching the driving mode to power mode with the intent of enabling engine braking, engine braking will not occur because dynamic radar cruise control with full-speed range will not be canceled. (→P.275)

⚠ WARNING

■ **When driving on slippery road surfaces**

Do not accelerate or shift gears suddenly. Sudden changes in engine braking may cause the vehicle to spin or skid, resulting in an accident.

⚠ NOTICE

■ **Hybrid battery (traction battery) charge**

If the shift lever is in N, the hybrid battery (traction battery) will not be charged even when the engine is running. Therefore, if the vehicle is left with the shift lever in N for a long period of time, the hybrid battery (traction battery) will discharge, and this may result in the vehicle not being able to start.

Shifting the shift lever

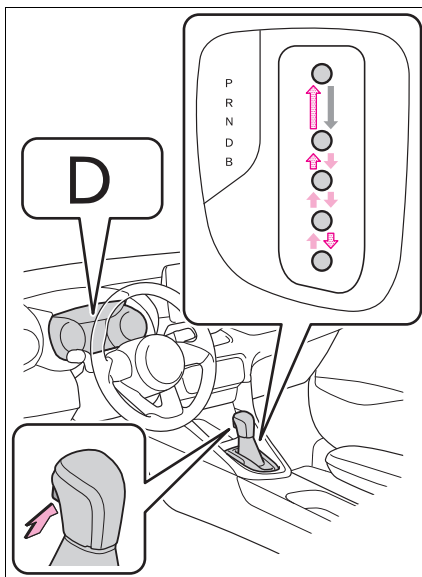

←: While the power switch is in

ON and the brake pedal depressed*, shift the shift lever while pushing the shift release button on the shift knob.

←: Shift the shift lever while pushing the shift release button on the shift knob.

←: Shift the shift lever normally.

When shifting the shift lever between P and D, make sure that the vehicle is completely stopped.

*: For the vehicle to be able to be shifted from P, the brake pedal must be depressed before the shift release button is pushed. If the shift release button is pushed first, the shift lock will not be released.

■ **Shift lock system**

The shift lock system is a system to prevent accidental operation of the shift lever in starting.

The shift lever can be shifted from P only when the power switch is in ON and the brake pedal is being depressed.

■ **If the shift lever cannot be shifted from P**

First, check whether the brake pedal is being depressed.

If the shift lever cannot be shifted with your foot on the brake pedal, there may be a problem with the shift lock system. Have the vehicle inspected by any authorized Toyota retailer or Toyota authorized repairer, or any reliable repairer immediately.

The following steps may be used as an emergency measure to ensure that the shift lever can be shifted.

Releasing the shift lock:

- 1 Set the parking brake.
- 2 Turn the power switch off.

- 3 Depress the brake pedal.
- 4 Ply the cover up with a flathead screwdriver or equivalent tool. To prevent damaging the cover, wrap the tip of the flathead screwdriver with a tape.

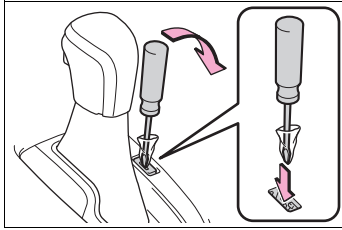

- 5 Press and hold the shift lock override button and then push the button on the shift knob.

The shift lever can be shifted while the both buttons are pressed.

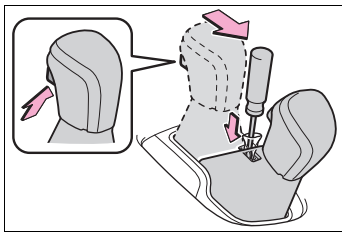

■ About engine braking

When shift position B is selected, releasing the accelerator pedal will apply engine braking.

- When the vehicle is driven at high speeds, compared to ordinary gasoline-fueled vehicles, the engine braking deceleration is felt less than that of other vehicles.
- The vehicle can be accelerated even when shift position B is selected.

If the vehicle is driven continuously in the B position, fuel efficiency will become low. Usually, select the D position.

! WARNING

■ To prevent an accident when releasing the shift lock

Before pressing the shift lock override button, make sure to set the parking brake and depress the brake pedal. If the accelerator pedal is accidentally depressed instead of the brake pedal when the shift lock override button is pressed and the shift lever is shifted out of P, the vehicle may suddenly start, possibly leading to an accident resulting in death or serious injury.

Selecting the driving mode

→P.275

Turn signal lever

Operating instructions

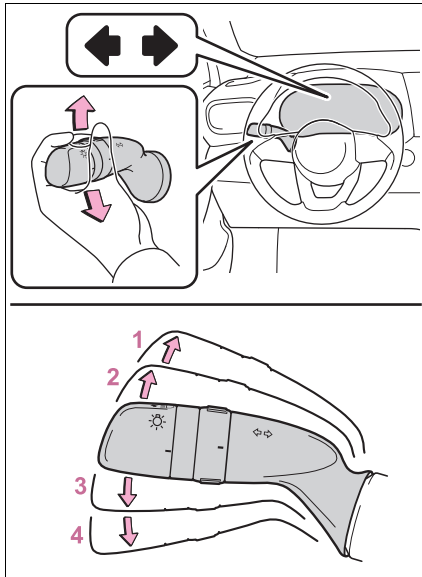

- 1 Right turn
- 2 Lane change to the right (move the lever partway and release it)
The right hand signals will flash 3 times.
- 3 Lane change to the left (move the lever partway and release it)
The left hand signals will flash 3 times.
- 4 Left turn

■ Turn signals can be operated when

The power switch is in ON.

■ If the indicator flashes faster than usual

Check that a light bulb in the front or rear turn signal lights has not burned out.

Parking brake

The parking brake can be set or released automatically or manually.

In automatic mode, the parking brake can be set or released automatically. Also, even in automatic mode, the parking brake can be set or released manually.

Operating instructions

■ Using the manual mode

The parking brake can be set and released manually.

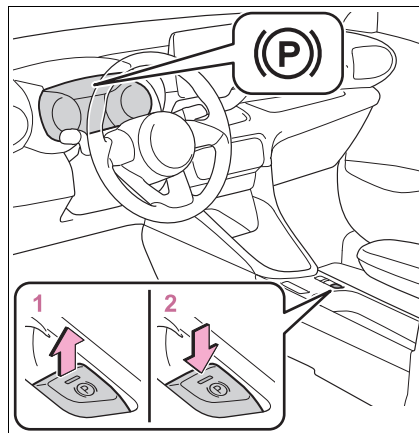

- 1 Pull the switch to set the parking brake

The parking brake indicator and parking brake light will turn on.

Pull and hold the parking brake switch if an emergency occurs and it is necessary to operate the parking brake while driving.

- 2 Push the switch to release the

parking brake

- Operate the parking brake switch while depressing the brake pedal.
- Using the parking brake automatic release function, the parking brake can be released by depressing the accelerator pedal. When using this function, slowly depress the accelerator pedal.

Make sure that the parking brake indicator and parking brake light turn off.

■ **Turning automatic mode on**

While the vehicle is stopped, pull and hold the parking brake switch until a message is shown on the multi-information display

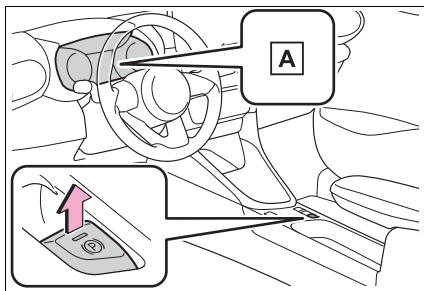

A “EPB Shift Interlock Function Activated”

When the automatic mode is turned on, the parking brake operates as follows.

- When the shift lever is moved out of P, the parking brake will be released, and the parking brake indicator and parking brake light will turn off.
- When the shift lever is moved into P, the parking brake will be set, and the parking brake indicator and parking brake light will

turn on.

Operate the shift lever with the vehicle stopped and the brake pedal depressed.

The parking brake may not operate automatically if the shift lever is moved quickly.

In this case, it is necessary to operate the parking brake switch. (→P.184)

■ **Turning automatic mode off**

While the vehicle is stopped and depressing the brake pedal, press and hold the parking brake switch until a message is shown on the multi-information display

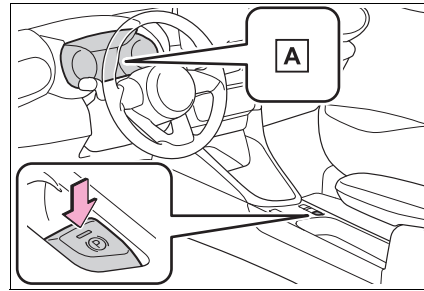

A “EPB Shift Interlock Function Deactivated”

■ **Parking brake operation**

- When the power switch is not in ON, the parking brake cannot be released using the parking brake switch.
- When the power switch is not in ON, automatic mode (automatic brake setting and releasing) is not available.

■ **Parking brake automatic release function**

The parking brake is automatically released when slowly depress the accelerator pedal.

The parking brake will be released automatically under the following conditions:

- The driver's door is closed
- The driver is wearing the seat belt
- The shift lever is in a forward or reverse position.
- The malfunction indicator lamp or brake system warning light is not illuminated.

If the automatic release function does not operate, manually release the parking brake.

■ **If “Parking Brake Temporarily Unavailable” is displayed on the multi-information display**

If the parking brake is operated repeatedly over a short period of time, the system may restrict operation to prevent overheating. If this happens, refrain from operating the parking brake. Normal operation will return after about 1 minute.

■ **If “Parking Brake Unavailable” is displayed on the multi-information display**

Operate the parking brake switch. If the message does not disappear after operating the switch several times, the system may be malfunctioning. Have the vehicle inspected by any authorized Toyota retailer or Toyota authorized repairer, or any reliable repairer.

■ **Parking brake operation sound**

When the parking brake operates, a motor sound (whirring sound) may be heard. This does not indicate a malfunction.

■ **Parking brake operation**

- Depending on the power switch mode, the parking brake indicator and parking brake light will turn on and stay on as described below:
ON: Comes on until the parking brake is released.
Not in ON: Stays on for approximately 15 seconds.
- When the power switch is turned off with the parking brake set, the parking brake indicator and parking brake light

will stay on for about 15 seconds. This does not indicate a malfunction.

■ **When the parking brake switch malfunctions**

Automatic mode (automatic brake setting and releasing) will be turned on automatically.

■ **Parking the vehicle**

→P.160

■ **Parking brake engaged warning buzzer**

A buzzer will sound if the vehicle is driven with the parking brake engaged. “Parking Brake ON” is displayed on the multi-information display. (with the vehicle reached a speed of 5 km/h [3 mph])

■ **If the brake system warning light comes on**

→P.374

■ **Usage in winter time**

→P.285

	WARNING
<p>■ When parking the vehicle</p> <p>Do not leave a child in the vehicle alone. The parking brake may be released unintentionally and there is the danger of the vehicle moving that may lead to an accident resulting in death or serious injury.</p>	
<p>■ Parking brake switch</p> <p>Do not set any objects near the parking brake switch. Objects may interfere with the switch and may lead the parking brake to unexpectedly operate.</p>	

	NOTICE
<p>■ When parking the vehicle</p> <p>Before you leave the vehicle, set the parking brake, shift the shift lever to P and make sure that the vehicle does not move.</p>	

**NOTICE****■ When the system malfunctions**

Stop the vehicle in a safe place and check the warning messages.

■ When the parking brake cannot be released due to a malfunction

Driving the vehicle with the parking brake set will lead to brake components overheating, which may affect braking performance and increase brake wear.

Have the vehicle inspected by any authorized Toyota retailer or Toyota authorized repairer, or any reliable repairer immediately if this occurs.

Brake Hold

The brake hold system keeps the brake applied when the shift lever is in D, B or N with the system on and the brake pedal has been depressed to stop the vehicle. The system releases the brake when the accelerator pedal is depressed with the shift lever in D or B to allow smooth start off.

Enabling the system

Turn the brake hold system on

The brake hold standby indicator (green) **A** comes on. While the system is holding the brake, the brake hold operated indicator (yellow) **B** comes on.

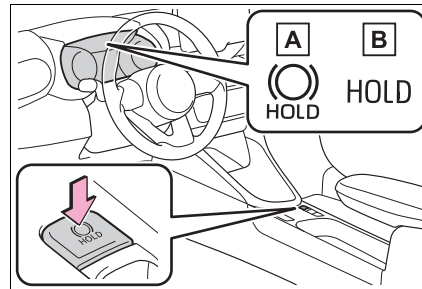
**■ Brake hold system operating conditions**

The brake hold system cannot be turned on in the following conditions:

- The driver's door is not closed.
- The driver is not wearing the seat belt.

If any of the conditions above are detected when the brake hold system is

enabled, the system will turn off and the brake hold standby indicator light will go off. In addition, if any of the conditions are detected while the system is holding the brake, a warning buzzer will sound and a message will be shown on the multi-information display. The parking brake will then be set automatically.

■ Brake hold function

- If the brake pedal is left released for a period of about 3 minutes after the system has started holding the brake, the parking brake will be set automatically. In this case, a warning buzzer sounds and a message is shown on the multi-information display.
- To turn the system off while the system is holding the brake, firmly depress the brake pedal and press the button again.
- The brake hold function may not hold the vehicle when the vehicle is on a steep incline. In this situation, it may be necessary for the driver to apply the brakes. A warning buzzer will sound and the multi-information display will inform the driver of this situation. If a warning message is shown on the multi-information display, read the message and follow the instructions.

■ When the parking brake is set automatically while the system is holding the brakes

Perform any of the following operations to release the parking brake.

- Depress the accelerator pedal. (The parking brake will not be released automatically if the seat belt is not fastened.)
- Operate the parking brake switch with the brake pedal depressed.

Make sure that the parking brake indicator light goes off. (→P.184)

■ When an inspection at any authorized Toyota retailer or Toyota authorized repairer, or any reliable repairer is necessary

When the brake hold standby indicator (green) does not illuminate even when the brake hold switch is pressed with the brake hold system operating conditions met, the system may be malfunctioning. Have the vehicle inspected at any authorized Toyota retailer or Toyota authorized repairer, or any reliable repairer.

■ If “Brake Hold Malfunction Press Brake to Deactivate Visit Your Dealer” or “Brake Hold Malfunction Visit Your Dealer” is displayed on the multi-information display

The system may be malfunctioning. Have the vehicle inspected by any authorized Toyota retailer or Toyota authorized repairer, or any reliable repairer.

■ Warning messages and buzzers

Warning messages and buzzers are used to indicate a system malfunction or to inform the driver of the need for caution. If a warning message is shown on the multi-information display, read the message and follow the instructions.

■ If the brake hold operated indicator flashes

→P.381

WARNING

■ When the vehicle is on a steep incline

When using the brake hold system on a steep incline, exercise caution. The brake hold function may not hold the vehicle in such a situation.

■ When stopped on a slippery road

The system cannot stop the vehicle when the gripping ability of the tires has been exceeded. Do not use the system when stopped on a slippery road.



NOTICE

■ When parking the vehicle

The brake hold system is not designed for use when parking the vehicle for a long period of time. Turning the power switch off while the system is holding the brake may release the brake, which would cause the vehicle to move. When operating the power switch, depress the brake pedal, shift the shift lever to P and set the parking brake.

Headlight switch

The headlights can be operated manually or automatically.

Operating instructions

Operating the ☀ switch turns on the lights as follows:

► Type A

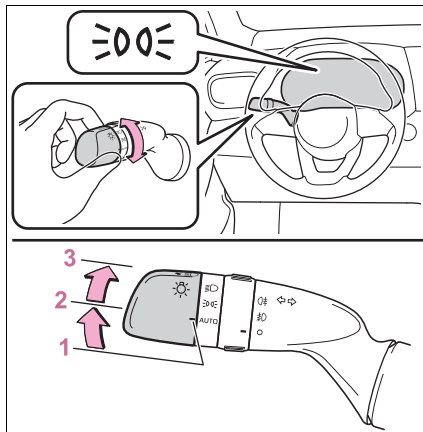

- 1 **AUTO** The headlights, daytime running lights (→P.190) and all the lights listed below turn on and off automatically.
- 2 **☀** The front position, tail, license plate and instrument panel lights turn on.
- 3 **☀** The headlights and all the lights listed above (except daytime running lights) turn on.

► Type B

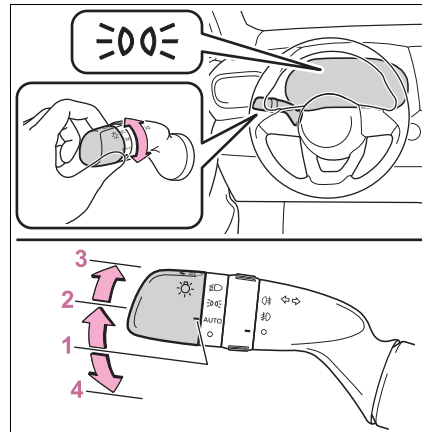

- 1 **AUTO** The headlights, daytime running lights (→P.190) and all the lights listed below turn on and off automatically.
- 2 **☀** The front position, tail, license plate and instrument panel lights turn on.
- 3 **☀** The headlights and all the lights listed above (except daytime running lights) turn on.
- 4 **☀** The daytime running lights turn on (→P.190)

■ **AUTO mode can be used when**

The power switch is in ON.

■ **Daytime running light system**

To make your vehicle more visible to other drivers during daytime driving, the daytime running lights turn on automatically whenever hybrid system is started and the parking brake is released with



the headlight switch in the **AUTO** or  position. (LED type headlights only: Illuminate brighter than the front position lights.) Daytime running lights are not designed for use at night.

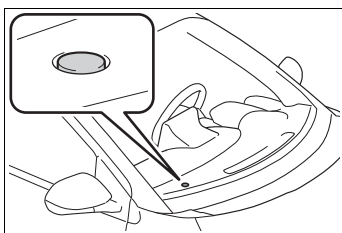

■ Headlight control sensor



The sensor may not function properly if an object is placed on the sensor, or anything that blocks the sensor is affixed to the windshield. Doing so interferes with the sensor detecting the level of ambient light and may cause the automatic headlight system to malfunction.

■ Automatic light off system

- When the light switch is in  or : The headlights and front fog lights (if equipped) turn off automatically if the power switch is turned to ACC or OFF.
- When the light switch is in **AUTO**: The headlights and all lights turn off automatically if the power switch is turned to ACC or OFF.

To turn the lights on again, turn the power switch to ON, or turn the light switch **AUTO** or  once and then back to  or .

■ Light reminder buzzer

A buzzer sounds when the power switch is turned to OFF or ACC and the driver's door is opened while the lights are

turned on.

■ When unlock the doors (welcome lamp) (vehicles with LED type headlights)

When the doors are unlocked using the entry function or wireless remote control, the front position lights turn on automatically.

When the light switch is in the **AUTO** position and the surrounding area is dark, this function will operate.

■ 12-volt battery-saving function

In order to prevent the 12-volt battery of the vehicle from discharging, if the light

switch is in the  or **AUTO** position when the power switch is turned off the 12-volt battery saving function will operate and automatically turn off all the lights after approximately 20 minutes. When the power switch is turned to ON, the 12-volt battery-saving function will be disabled.

When any of the following are performed, the 12-volt battery-saving function is canceled once and then reactivated. All the lights will turn off automatically 20 minutes after the 12-volt battery-saving function has been reactivated:

- When the headlight switch is operated
- When a door is opened or closed

■ Customization

Some functions can be customized. (→P.431)

NOTICE

■ To prevent 12-volt battery discharge

Do not leave the lights on longer than necessary when the hybrid system is off.

Turning on the high beam headlights

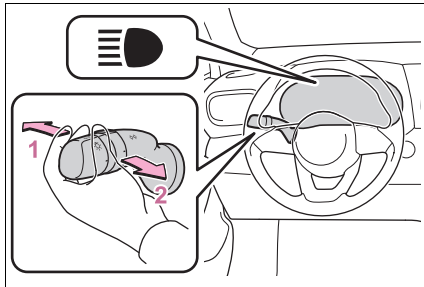

- 1 With the headlights on, push the lever away from you to turn on the high beams.

Pull the lever toward you to the center position to turn the high beams off.

- 2 Pull the lever toward you and release it to flash the high beams once.

You can flash the high beams with the headlights on or off.

Headlamp temporary lighting function

This system allows the headlights to be turned on for 30 seconds when the power switch is off.

Pull the lever toward you and release it with the light switch in **AUTO** or **⦿** after turning the power switch off.

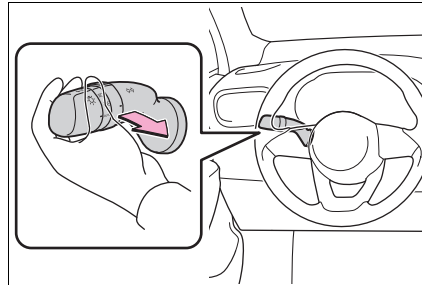

The lights are turned off in the following situations.

- The power switch is turned to ON.
- The light switch is turned on.
- The light switch is pulled toward you and then released.

Manual headlight leveling dial

The level of the headlights can be adjusted according to the number of passengers and the loading condition of the vehicle.

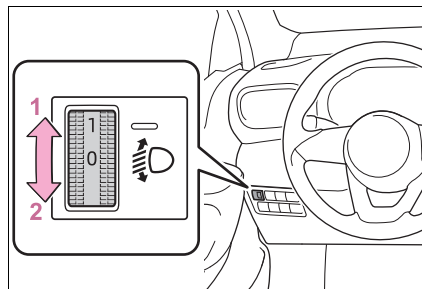

- 1 Raises the level of the headlights
- 2 Lowers the level of the headlights

■ Guide to dial settings

▶ Left-hand drive vehicles

Occupancy and luggage load conditions		Dial position
Occupants	Luggage load	
Driver	None	0
Driver and front passenger	None	0.5
All seats occupied	None	1.5
All seats occupied	Full luggage loading	2.5
Driver	Full luggage loading	3.5

▶ Right-hand drive vehicles

Occupancy and luggage load conditions		Dial position
Occupants	Luggage load	
Driver	None	0
Driver and front passenger	None	0.5
All seats occupied	None	1.5
All seats occupied	Full luggage loading	2.5
Driver	Full luggage loading	3

AHB (Automatic High Beam)*

*: If equipped

The Automatic High Beam uses a front camera located behind the upper portion of the windshield to assess the brightness of the lights of vehicles ahead, streetlights, etc., and automatically turns the high beams on or off as necessary.

⚠ WARNING

■ Limitations of the Automatic High Beam

Do not overly rely on the Automatic High Beam. Always drive safely, taking care to observe your surroundings and turning the high beams on or off manually if necessary.

■ To prevent incorrect operation of the Automatic High Beam system

Do not overload the vehicle.

Activating the Automatic High Beam

- 1 Press the Automatic High Beam switch.

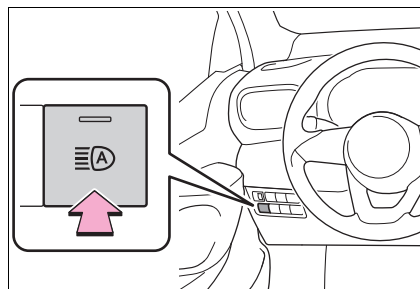

2 Turn the headlight switch to the

 or AUTO position.

The Automatic High Beam indicator will come on when the system is operating.

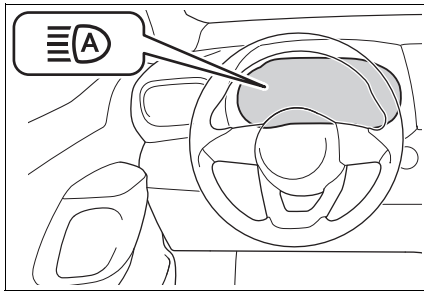

■ **Conditions to turn the high beams on/off automatically**

- When all of the following conditions are met, the high beams will be turned on automatically (after approximately 1 second):
 - The vehicle speed is approximately 30 km/h (19 mph) or more.
 - The area ahead of the vehicle is dark.
 - There are no vehicles ahead with headlights or tail lights turned on.
 - There are few streetlights on the road ahead.
- If any of the following conditions are met, the high beams will turn off automatically:
 - The vehicle speed is below approximately 25 km/h (16 mph).
 - The area ahead of the vehicle is not dark.
 - Vehicles ahead have their headlights or tail lights turned on.
 - There are many streetlights on the road ahead.

■ **Front camera detection information**

- The high beams may not be automatically turned off in the following situations:
 - When a vehicle suddenly appears from around a curve
 - When the vehicle is cut in front of by another vehicle

- When vehicles ahead cannot be detected due to repeated curves, road dividers or roadside trees
- When vehicles ahead appear in a far-away lane on a wide road
- When the lights of vehicles ahead are not on
- The high beams may be turned off if a vehicle ahead that is using fog lights without its headlights turned on is detected.
- House lights, streetlights, traffic signals, and illuminated billboards or signs and other reflective objects may cause the high beams to change to the low beams, or the low beams to remain on.
- The following factors may affect the amount of time taken for the high beams to turn on or off:
 - The brightness of the headlights, fog lights, and tail lights of vehicles ahead
 - The movement and direction of vehicles ahead
 - When a vehicle ahead only has operational lights on one side
 - When a vehicle ahead is a two-wheeled vehicle
 - The condition of the road (gradient, curve, condition of the road surface, etc.)
 - The number of passengers and amount of luggage in the vehicle
- The high beams may turn on or off unexpectedly.
- Bicycles or similar vehicles may not be detected.
- In the following situations the system may not be able to correctly detect the surrounding brightness level. This may cause the low beams to remain on or the high beams to flash or dazzle pedestrians or vehicles ahead. In such a case, it is necessary to manually switch between the high and low beams.
 - When driving in inclement weather (heavy rain, snow, fog, sandstorms, etc.)
 - When the windshield is obscured by

- fog, mist, ice, dirt, etc.
- When the windshield is cracked or damaged
 - When the front camera is deformed or dirty
 - When the temperature of the front camera is extremely high
 - When the surrounding brightness level is equal to that of headlights, tail lights or fog lights
 - When headlights or tail lights of vehicles ahead are turned off, dirty, changing color, or not aimed properly
 - When the vehicle is hit by water, snow, dust, etc., from a preceding vehicle
 - When driving through an area of intermittently changing brightness and darkness
 - When frequently and repeatedly driving ascending/descending roads, or roads with rough, bumpy or uneven surfaces (such as stone-paved roads, gravel roads, etc.)
 - When frequently and repeatedly taking curves or driving on a winding road
 - When there is a highly reflective object ahead of the vehicle, such as a sign or mirror
 - When the back of a preceding vehicle is highly reflective, such as a container on a truck
 - When the vehicle's headlights are damaged or dirty, or are not aimed properly
 - When the vehicle is listing or tilting due to a flat tire, a trailer being towed, etc.
 - When the headlights are changed between the high beams and low beams repeatedly in an abnormal manner
 - When the driver believes that the high beams may be flashing or dazzling pedestrians or other drivers

Turning the high beams on/off manually

■ Switching to the high beams

Push the lever away from you.

The Automatic High Beam indicator will turn off and the high beam indicator will turn on.

Pull the lever to its original position to activate the Automatic High Beam system again.

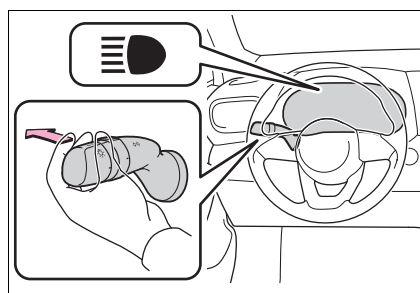

■ Switching to the low beams

Press the Automatic High Beam switch.

The Automatic High Beam indicator will turn off.

Press the switch to activate the Automatic High Beam system again.

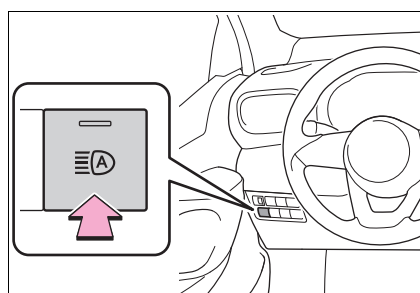

■ Temporarily switching to the low beams

Pull the lever toward you and then

return it to its original position.

The high beams are on while the lever is pulled toward you, however, after the lever is returned to its original position, the low beams remain on for a certain amount of time. Afterwards, the Automatic High Beam will be activated again.

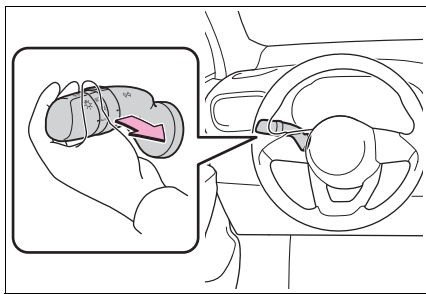

■ **Temporarily switching to the low beams**

It is recommended to switch to the low beams when the high beam may cause problems or distress to other drivers or pedestrians nearby.

Fog light switch

The fog lights secure excellent visibility in difficult driving conditions, such as in rain and fog.

Operating instructions

► **Rear fog light switch**

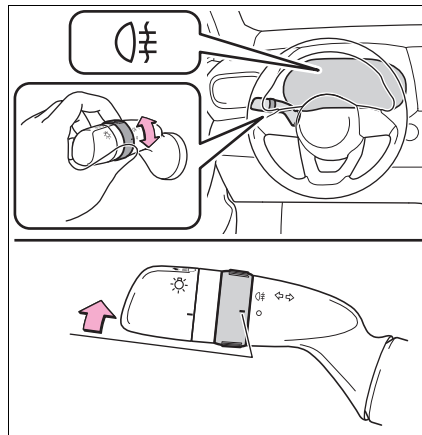

☞ Turns the rear fog light on

Releasing the switch ring returns it

to ○ .

Operating the switch ring again turns the rear fog light off.

▶ Front and rear fog light switch

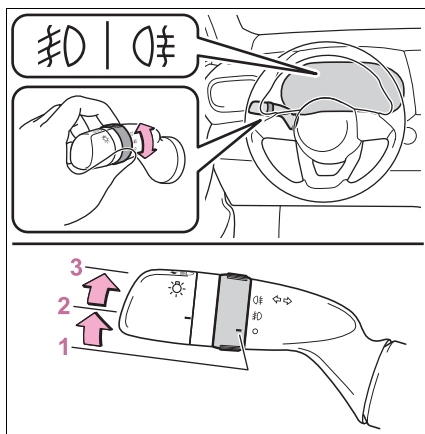

- 1 ○ Turns the front fog lights off
- 2 ⓪ Turns the front fog lights on
- 3 Ⓛ Turns the front and rear fog light on

Releasing the switch ring returns it to ⓪.

Operating the switch ring again turns only the rear fog light off.

■ Fog lights can be used when

- Vehicles with a rear fog light switch
The headlights are turned on.
- Vehicles with a front and rear fog light switch
The headlights or the front fog lights are turned on.

Windshield wipers and washer

Operating the lever can use the windshield wipers or the washer.

⚠ NOTICE

- **When the windshield is dry**
Do not use the wipers, as they may damage the windshield.

Operating the wiper lever

Operating the  lever operates the wipers or washer as follows.

- ▶ Intermittent windshield wipers with interval adjuster

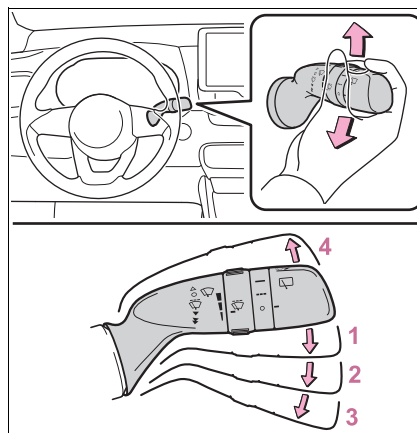

- 1  Intermittent windshield wiper operation
- 2 ▼ Low speed windshield wiper operation
- 3 ▼ High speed windshield wiper operation

wiper operation

4 ▲ Temporary operation

Wiper intervals can be adjusted when intermittent operation is selected.

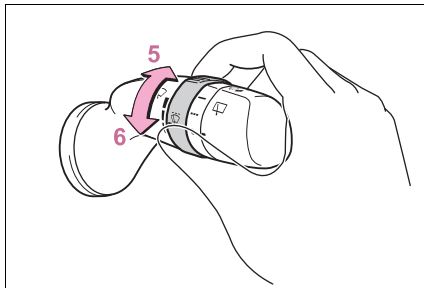

5 Increases the intermittent windshield wiper frequency

6 Decreases the intermittent windshield wiper frequency

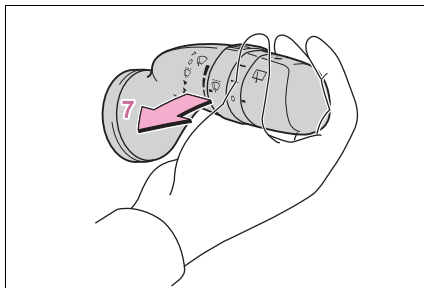

7  Washer/wiper dual operation

Pulling the lever operates the wipers and washer.

Wipers will automatically operate a couple of times after the washer squirts.

► Rain-sensing windshield wipers

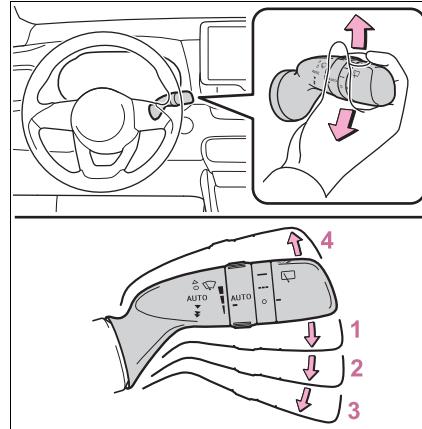

1 AUTO Rain-sensing windshield wiper operation

2 ▼ Low speed windshield wiper operation

3 ▼ High speed windshield wiper operation

4 ▲ Temporary operation

When "AUTO" is selected, the wipers will operate automatically when the sensor detects falling rain. The system automatically adjusts wiper timing in accordance with rain volume and vehicle speed.

When "AUTO" is selected, the sensor sensitivity can be adjusted as follows by turning the switch ring.

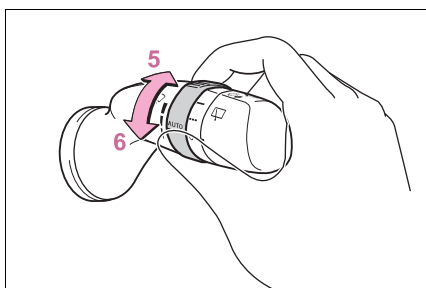

5 Increases the rain-sensing windshield wiper sensitivity

6 Decreases the rain-sensing windshield wiper sensitivity

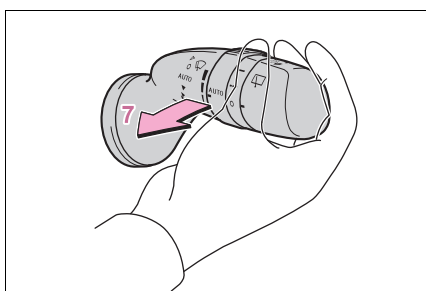

7  Washer/wiper dual operation

Pulling the lever operates the wipers and washer.

Wipers will automatically operate a couple of times after the washer squirts.

■ **The windshield wiper and washer can be operated when**

The power switch is in ON.

■ **Effects of vehicle speed on wiper operation (vehicles with rain-sensing windshield wipers)**

Vehicle speed affects the Intermittent wiper interval.

■ **Raindrop sensor (vehicles with rain-sensing windshield wipers)**

- The raindrop sensor judges the amount of raindrops.

An optical sensor is adopted. It may not operate properly when sunlight from the rising or setting of the sun intermittently strikes the windshield, or if bugs etc. are present on the windshield.

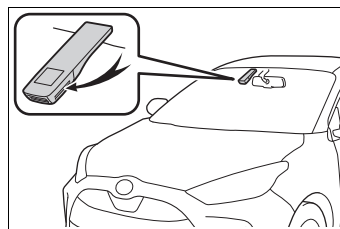

- If the wiper is turned to AUTO mode while the power switch is in ON, the wipers will operate once to show that AUTO mode is activated.
- If the temperature of the raindrop sensor is 85°C (185°F) or higher, or -15°C (5°F) or lower, automatic operation may not occur. In this case, operate the wipers in any mode other than AUTO mode.

■ **If no windshield washer fluid sprays**

Check that the washer nozzles are not blocked if there is washer fluid in the windshield washer fluid reservoir.

 **WARNING**

■ **Caution regarding the use of windshield wipers in AUTO mode (vehicles with rain-sensing windshield wipers)**

The windshield wipers may operate unexpectedly if the sensor is touched or the windshield is subject to vibration in AUTO mode. Take care that your fingers or anything else do not become caught in the windshield wipers.

⚠ WARNING

■ **Caution regarding the use of washer fluid**

When it is cold, do not use the washer fluid until the windshield becomes warm. The fluid may freeze on the windshield and cause low visibility. This may lead to an accident, resulting in death or serious injury.

⚠ NOTICE

■ **When there is no washer fluid spray from the nozzle**

Damage to the washer fluid pump may be caused if the lever is pulled toward you and held continually.

■ **When a nozzle becomes blocked**

In this case, contact any authorized Toyota retailer or Toyota authorized repairer, or any reliable repairer. Do not try to clear it with a pin or other object. The nozzle will be damaged.

Rear window wiper and washer*

*: If equipped

Operating the lever can use the rear window wiper or the washer.

⚠ NOTICE

■ **When the rear window is dry**

Do not use the wiper, as it may damage the rear window.

Operating instructions

Operating the  switch operates the rear wiper as follows:

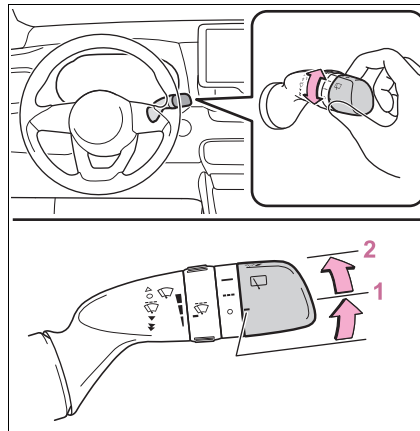

1 ■■■ Intermittent window wiper operation

2 — Normal window wiper operation

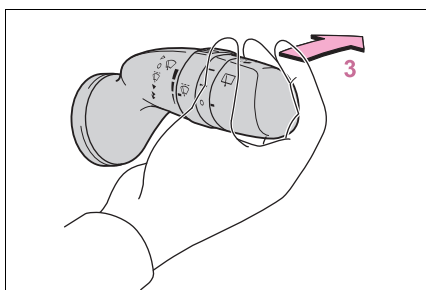

3 Washer/wiper dual operation

Pushing the lever operates the wiper and washer.

The wiper will automatically operate a couple of times after the washer squirts.

■ The rear window wiper and washer can be operated when

The power switch is in ON.

■ If no windshield washer fluid sprays

Check that the washer nozzle is not blocked if there is washer fluid in the windshield washer fluid reservoir.

■ Reverse-linked rear window wiper function

When the shift lever is shifted to R when the front wipers are operating, the rear window wiper will operate once.

■ Back door opening linked rear window wiper stop function

When the rear window wiper are operating, if a back door is opened while the vehicle is stopped, operation of the rear window wiper will be stopped to prevent anyone near the vehicle from being sprayed by water from the wiper. When the back door is closed, wiper operation will resume.*

*: These settings must be customized at any authorized Toyota retailer or Toyota authorized repairer, or any reliable repairer.

NOTICE

■ When the washer fluid tank is empty

Do not operate the switch continually as the washer fluid pump may overheat.

■ When a nozzle becomes blocked

In this case, contact any authorized Toyota retailer or Toyota authorized repairer, or any reliable repairer. Do not try to clear it with a pin or other object. The nozzle will be damaged.

Opening the fuel tank cap

Perform the following steps to open the fuel tank cap:

Before refueling the vehicle

- Turn the power switch off and ensure that all the doors and windows are closed.
- Confirm the type of fuel.

Fuel types

→P.430

Fuel tank opening for unleaded gasoline

To help prevent incorrect fueling, your vehicle has a fuel tank opening that only accommodates the special nozzle on unleaded fuel pumps.



WARNING

When refueling the vehicle

Observe the following precautions while refueling the vehicle. Failure to do so may result in death or serious injury.

- After exiting the vehicle and before opening the fuel door, touch an unpainted metal surface to discharge any static electricity. It is important to discharge static electricity before refueling because sparks resulting from static electricity can cause fuel vapors to ignite while refueling.

- Always hold the grips on the fuel tank cap and turn it slowly to remove it. A whooshing sound may be heard when the fuel tank cap is loosened. Wait until the sound cannot be heard before fully removing the cap. In hot weather, pressurized fuel may spray out the filler neck and cause injury.

- Do not allow anyone that has not discharged static electricity from their body to come close to an open fuel tank.

- Do not inhale vaporized fuel. Fuel contains substances that are harmful if inhaled.

- Do not smoke while refueling the vehicle. Doing so may cause the fuel to ignite and cause a fire.

- Do not return to the vehicle or touch any person or object that is statically charged. This may cause static electricity to build up, resulting in a possible ignition hazard.

When refueling

Observe the following precautions to prevent fuel overflowing from the fuel tank:

- Securely insert the fuel nozzle into the fuel filler neck.
- Stop filling the tank after the fuel nozzle automatically clicks off.
- Do not top off the fuel tank.

 NOTICE

■ Refueling

Do not spill fuel during refueling. Doing so may damage the vehicle, such as causing the emission control system to operate abnormally or damaging fuel system components or the vehicle's painted surface.

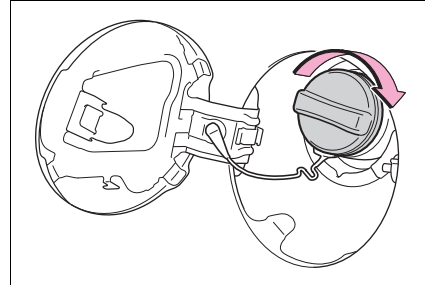
Opening the fuel tank cap

- 1 Pull up the opener to open the fuel filler door.

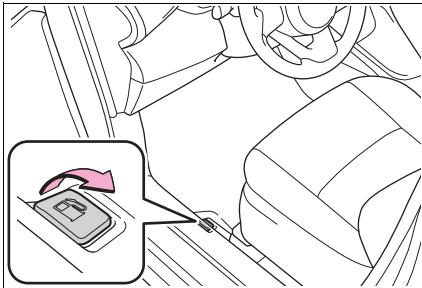

- 2 Turn the fuel tank cap slowly and remove it, then hang it on the back of the fuel filler door.

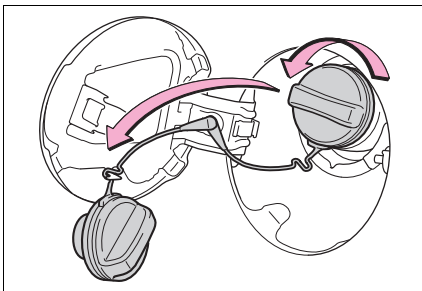
Closing the fuel tank cap

After refueling, turn the fuel tank cap until you hear a click. Once the cap is released, it will turn slightly in the opposite direction.

 **WARNING**
■ When replacing the fuel tank cap

Do not use anything but a genuine Toyota fuel tank cap designed for your vehicle. Doing so may cause a fire or other incident which may result in death or serious injury.

Toyota Safety Sense*

*: If equipped

The Toyota Safety Sense consists of the following drive assist systems and contributes to a safe and comfortable driving experience:

Driving assist system

- **PCS (Pre-Collision System)**
→P.209
- **LTA (Lane Tracing Assist)**
→P.220
- **AHB (Automatic High Beam)**
→P.193
- **RSA (Road Sign Assist) (if equipped)**
→P.244
- **Dynamic radar cruise control with full-speed range**
→P.230

WARNING

■ **Toyota Safety Sense**

The Toyota Safety Sense is designed to operate under the assumption that the driver will drive safely, and is designed to help reduce the impact to the occupants and the vehicle in the case of a collision or assist the driver in normal driving conditions. As there is a limit to the degree of recognition accuracy and control performance that this system can provide, do not overly rely on this system. The driver is always responsible for paying attention to the vehicle's surroundings and driving safely.

Sensors

Two types of sensors, located behind the front grille and windshield, detect information necessary to operate the drive assist systems.

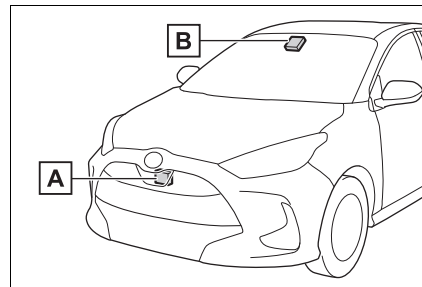

A Radar sensor

B Front camera

⚠ WARNING**■ To avoid malfunction of the radar sensor**

Observe the following precautions. Otherwise, the radar sensor may not operate properly, possibly leading to an accident resulting in death or serious injury.

- Keep the radar sensor and the radar sensor cover clean at all times.

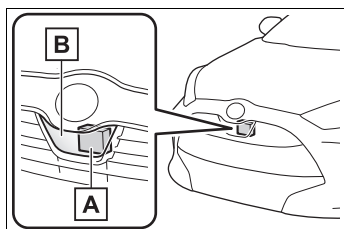

A Radar sensor

B Radar sensor cover

If the front of the radar sensor or the front or back of the radar sensor cover is dirty or covered with water droplets, snow, etc., clean it.

Clean the radar sensor and radar sensor cover with a soft cloth to avoid damaging them.

- Do not attach accessories, stickers (including transparent stickers) or other items to the radar sensor, radar sensor cover or surrounding area.
- Do not subject the radar sensor or its surrounding area to a strong impact.
If the radar sensor, front grille, or front bumper has been subjected to a strong impact, have the vehicle inspected by any authorized Toyota retailer or Toyota authorized repairer, or any reliable repairer.

- Do not disassemble the radar sensor.

- Do not modify or paint the radar sensor or radar sensor cover.

- In the following cases, the radar sensor must be recalibrated. Contact any authorized Toyota retailer or Toyota authorized repairer, or any reliable repairer for details.

- When the radar sensor or front grille are removed and installed, or replaced

- When the front bumper is replaced

■ To avoid malfunction of the front camera

Observe the following precautions. Otherwise, the front camera may not operate properly, possibly leading to an accident resulting in death or serious injury.

- Keep the windshield clean at all times.
- If the windshield is dirty or covered with an oily film, water droplets, snow, etc., clean the windshield.
- If a glass coating agent is applied to the windshield, it will still be necessary to use the windshield wipers to remove water droplets, etc., from the area of the windshield in front of the front camera.
- If the inner side of the windshield where the front camera is installed is dirty, contact any authorized Toyota retailer or Toyota authorized repairer, or any reliable repairer.

⚠ WARNING

- Do not attach objects, such as stickers, transparent stickers, etc., to the outer side of the windshield in front of the front camera (shaded area in the illustration).

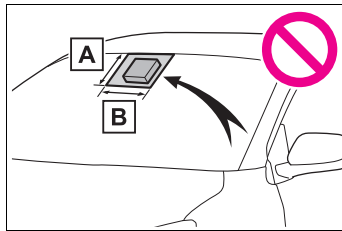

A From the top of the windshield to approximately 1 cm (0.4 in.) below the bottom of the front camera

B Approximately 20 cm (7.9 in.) (Approximately 10 cm [4.0 in.] to the right and left from the center of the front camera)

- If the part of the windshield in front of the front camera is fogged up or covered with condensation or ice, use the windshield defogger to remove the fog, condensation or ice. (→P.290)
- If water droplets cannot be properly removed from the area of the windshield in front of the front camera by the windshield wipers, replace the wiper insert or wiper blade.
- Do not attach window tint to the windshield.
- Replace the windshield if it is damaged or cracked. After replacing the windshield, the front camera must be recalibrated. Contact any authorized Toyota retailer or Toyota authorized repairer, or any reliable repairer for details.

- Do not allow liquids to contact the front camera.
- Do not allow bright lights to shine into the front camera.
- Do not dirty or damage the front camera. When cleaning the inside of the windshield, do not allow glass cleaner to contact the lens of the front camera. Also, do not touch the lens. If the lens is dirty or damaged, contact any authorized Toyota retailer or Toyota authorized repairer, or any reliable repairer.
- Do not subject the front camera to a strong impact.
- Do not change the installation position or direction of the front camera or remove it.
- Do not disassemble the front camera.
- Do not modify any components of the vehicle around the front camera (inside rear view mirror, etc.) or ceiling.
- Do not attach any accessories to the hood, front grille or front bumper that may obstruct the front camera. Contact any authorized Toyota retailer or Toyota authorized repairer, or any reliable repairer for details.
- If a surfboard or other long object is to be mounted on the roof, make sure that it will not obstruct the front camera.
- Do not modify the headlights or other lights.

■ **Certifications for the Toyota Safety Sense**

→P.531

■ **If a warning message is displayed on the multi-information display**

A system may be temporarily unavailable or there may be a malfunction in the system.

- In the following situations, perform the actions specified in the table. When the normal operating conditions are detected, the message will disappear and the system will become operational.

If the message does not disappear, contact any authorized Toyota retailer or Toyota authorized repairer, or any reliable repairer.

Situation	Actions
When the area around a camera is covered with dirt, moisture (fogged up, covered with condensation, ice, etc.), or other foreign matter	Using the wiper and A/C function, remove the dirt and other attached matter. (→P.290).
When the temperature around the front camera is outside of the operational range, such as when the vehicle is in the sun or in an extremely cold environment	If the front camera is hot, such as after the vehicle had been parked in the sun, use the air conditioning system to decrease the temperature around the front camera.
	If a sunshade was used when the vehicle was parked, depending on its type, the sunlight reflected from the surface of the sunshade may cause the temperature of the front camera to become excessively high.
	If the front camera is cold, such after the vehicle is parked in an extremely cold environment, use the air conditioning system to increase the temperature around the front camera.
The area in front of the front camera is obstructed, such as when the hood is open or a sticker is attached to the part of the windshield in front of the front camera.	Close the hood, remove the sticker, etc., to clear the obstruction.
When “Pre-Collision System Radar In Self Calibration Unavailable See Owner’s Manual” is displayed.	Check whether there is attached materials on the radar sensor and radar sensor cover, and if there is, remove it.

208 4-5. Using the driving support systems

- In the following situations, if the situation has changed (or the vehicle has been driven for some time) and the normal operating conditions are detected, the message will disappear and the system will become operational.

If the message does not disappear, contact any authorized Toyota retailer or Toyota authorized repairer, or any reliable repairer.

- When the temperature around the radar sensor is outside of the operational range, such as when the vehicle is in the sun or in an extremely cold environment
- When the front camera cannot detect objects in front of the vehicle, such as when driving in the dark, snow, or fog, or when bright lights are shining into the front camera
- Depending on the conditions in the vicinity of the vehicle, the radar may judge the surrounding environment can not be properly recognized. In that case, "Pre-Collision System Unavailable See Owner's Manual" is displayed.

PCS (Pre-Collision System)*

*: If equipped

The pre-collision system uses a radar sensor and front camera to detect objects (→P.209) in front of the vehicle. When the system determines that the possibility of a frontal collision with an object is high, a warning operates to urge the driver to take evasive action and the potential brake pressure is increased to help the driver avoid the collision. If the system determines that the possibility of a frontal collision with an object is extremely high, the brakes are automatically applied to help avoid the collision or help reduce the impact of the collision.

The pre-collision system can be disabled/enabled and the warning timing can be changed. (→P.212)

Detectable objects

The system can detect the following (The detectable objects differs depending on the function.):

- Vehicles
- Bicyclists
- Pedestrians

System functions

■ Pre-collision warning

When the system determines that the possibility of a frontal collision is high, a buzzer will sound and a warning message will be displayed on the multi-information display to urge the driver to take evasive action.

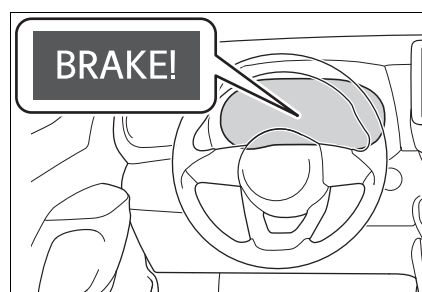

■ Pre-collision brake assist

When the system determines that the possibility of a frontal collision is high, the system applies greater braking force in relation to how strongly the brake pedal is depressed.

■ Pre-collision braking

If the system determines that the possibility of a frontal collision is extremely high, the brakes are automatically applied to help avoid the collision or reduce the impact of the collision.

■ Emergency steering assist

If the system determines that the possibility of a collision with a pedestrian is high and that there is sufficient space for the vehicle to be

steered into within its lane, and the driver has begun evasive maneuver or steering, emergency steering assist will assist the steering movements to help enhance the vehicle stability and for lane departure prevention. During operation, the indicator will illuminate in green.

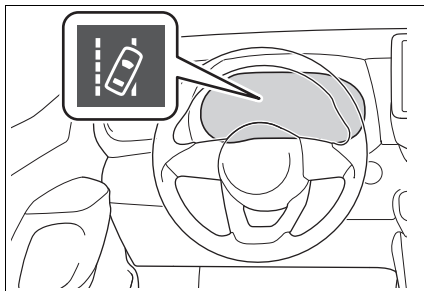

■ **Intersection right/left turn assistance**

If the system determines that there is a high possibility of a collision in the following situations, it will assist with Pre-collision warning and, if necessary Pre-collision braking.

Depending on the configuration of the intersection, it may not be possible to stop.

- When you turn right/left at an intersection and cross the path of an oncoming vehicle

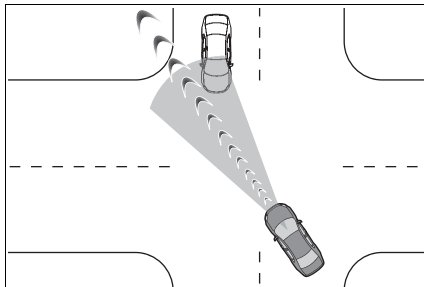

- When you turn right/left, pedestrian is detected in the forward direction and estimated to enter your vehicle's path (bicyclists are not detected.)

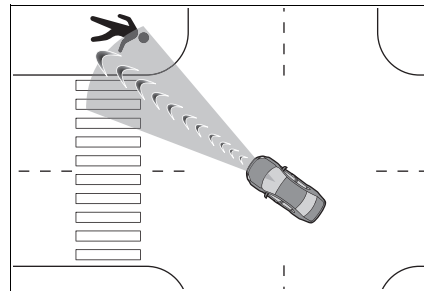

⚠ WARNING

■ **Limitations of the pre-collision system**

- The driver is solely responsible for safe driving. Always drive safely, taking care to observe your surroundings.

Do not use the pre-collision system instead of normal braking operations under any circumstances. This system will not prevent collisions or lessen collision damage or injury in every situation. Do not overly rely on this system. Failure to do so may lead to an accident, resulting in death or serious injury.

- Although this system is designed to help avoid a collision or help reduce the impact of the collision, its effectiveness may change according to various conditions, therefore the system may not always be able to achieve the same level of performance. Read the following conditions carefully. Do not overly rely on this system and always drive carefully.

- Conditions under which the system may operate even if there is no possibility of a collision: →P.215

⚠ WARNING

- Conditions under which the system may not operate properly: →P.217

- Do not attempt to test the operation of the pre-collision system yourself. Depending on the objects used for testing (dummies, cardboard objects imitating detectable objects, etc.), the system may not operate properly, possibly leading to an accident.

■ Pre-collision braking

- When the pre-collision braking function is operating, a large amount of braking force will be applied.
- If the vehicle is stopped by the operation of the pre-collision braking function, the pre-collision braking function operation will be canceled after approximately 2 seconds. Depress the brake pedal as necessary.
- The pre-collision braking function may not operate if certain operations are performed by the driver. If the accelerator pedal is being depressed strongly or the steering wheel is being turned, the system may determine that the driver is taking evasive action and possibly prevent the pre-collision braking function from operating.
- In some situations, while the pre-collision braking function is operating, operation of the function may be canceled if the accelerator pedal is depressed strongly or the steering wheel is turned and the system determines that the driver is taking evasive action.

- If the brake pedal is being depressed, the system may determine that the driver is taking evasive action and possibly delay the operation timing of the pre-collision braking function.

■ Emergency steering assist

- As emergency steering assist operation will be canceled when the system determines that lane departure prevention function has been completed.

- Emergency steering assist may not operate or may be canceled in the following cases as the system may determine the driver is taking actions.

- If the accelerator pedal is being depressed strongly, the steering wheel is being operated sharply, the brake pedal is being depressed or the turn signal lever is being operated. In this case, the system may determine that the driver is taking evasive action and the emergency steering assist may not operate.
- In some situations, while the emergency steering assist is operating, operation of the function may be canceled if the accelerator pedal is depressed strongly, the steering wheel is operated sharply or the brake pedal is being depressed and the system determines that the driver is taking evasive action.
- When the emergency steering assist is operating, if the steering wheel is held firmly or is operated in the opposite direction to that which the system is generating torque, the function may be canceled.

⚠ WARNING

■ **When to disable the pre-collision system**

In the following situations, disable the system, as it may not operate properly, possibly leading to an accident resulting in death or serious injury:

- When the vehicle is being towed
- When your vehicle is towing another vehicle
- When transporting the vehicle via truck, boat, train or similar means of transportation
- When the vehicle is raised on a lift with the hybrid system on and the tires are allowed to rotate freely
- When inspecting the vehicle using a drum tester such as a chassis dynamometer or speedometer tester, or when using an on vehicle wheel balancer
- When a strong impact is applied to the front bumper or front grille, due to an accident or other reasons
- If the vehicle cannot be driven in a stable manner, such as when the vehicle has been in an accident or is malfunctioning
- When the vehicle is driven in a sporty manner or off-road
- When the tires are not properly inflated
- When the tires are very worn
- When tires of a size other than specified are installed
- When tire chains are installed
- When a compact spare tire or an emergency tire puncture repair kit is used

- If equipment (snow plow, etc.) that may obstruct the radar sensor or front camera is temporarily installed to the vehicle

Changing settings of the pre-collision system

■ **Enabling/disabling the pre-collision system**

The pre-collision system can be enabled/disabled on  (→P.431) of the multi-information display.

The system is automatically enabled each time the power switch is turned to ON.

If the system is disabled, the PCS warning light will turn on and a message will be displayed on the multi-information display.

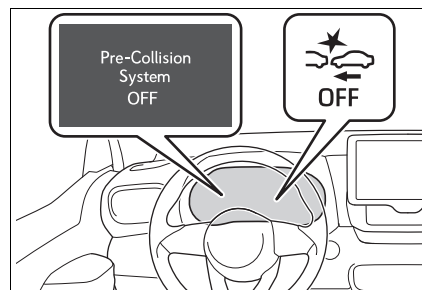

■ **Changing the pre-collision warning timing**

The pre-collision warning timing can be changed on  (→P.431) of the multi-information display.

The warning timing setting is retained when the power switch is turned off. However, if the pre-collision system is disabled and re-enabled, the operation

timing will return to the default setting (middle).

If the pre-collision warning timing is changed, emergency steering assist timing will also be changed accordingly. If late is selected, emergency steering assist would not operate in case of an emergency.

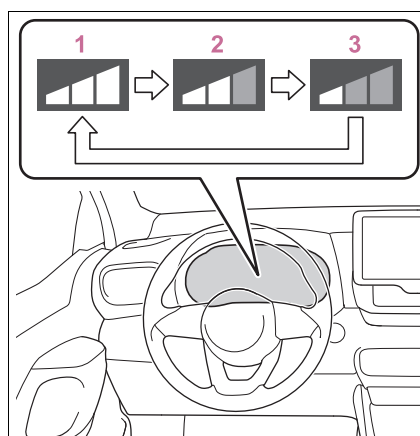

- 1** Early
- 2** Middle
This is the default setting.
- 3** Late

Operational conditions for each pre-collision function

The pre-collision system is enabled and the system determines that the possibility of a frontal collision with a detected object is high.

The system may not operate in the following situations:

- If a 12-volt battery terminal has been disconnected and reconnected and then the vehicle has not been driven for a certain amount of time
- If the shift lever is in R
- When the VSC OFF indicator is illuminated (only the pre-collision warning function will be operational)

The operation speeds and operation cancellation for each function is listed below.

● Pre-collision warning

Detectable objects	Vehicle speed	Relative speed between your vehicle and object
Vehicles	Approx. 10 to 180 km/h (7 to 110 mph)	Approx. 10 to 180 km/h (7 to 110 mph)
Bicyclists and pedestrians	Approx. 10 to 80 km/h (7 to 50 mph)	Approx. 10 to 80 km/h (7 to 50 mph)

214 4-5. Using the driving support systems

● Pre-collision brake assist

Detectable objects	Vehicle speed	Relative speed between your vehicle and object
Vehicles	Approx. 30 to 180 km/h (20 to 110 mph)	Approx. 30 to 180 km/h (20 to 110 mph)
Bicyclists and pedestrians	Approx. 30 to 80 km/h (20 to 50 mph)	Approx. 30 to 80 km/h (20 to 50 mph)

● Pre-collision braking

Detectable objects	Vehicle speed	Relative speed between your vehicle and object
Vehicles	Approx. 10 to 180 km/h (7 to 110 mph)	Approx. 10 to 180 km/h (7 to 110 mph)
Bicyclists and pedestrians	Approx. 10 to 80 km/h (7 to 50 mph)	Approx. 10 to 80 km/h (7 to 50 mph)

If either of the following occur while the pre-collision braking function is operating, it will be canceled:

- The accelerator pedal is depressed strongly.
- The steering wheel is turned sharply or abruptly.

● Emergency steering assist

When the turn signal lights are flashing, emergency steering assist will not operate in case of an emergency.

Detectable objects	Vehicle speed	Relative speed between your vehicle and object
Pedestrians	Approx. 40 to 80 km/h (25 to 50 mph)	Approx. 40 to 80 km/h (25 to 50 mph)

If any of the following occur while the emergency steering assist function is operating, it will be canceled:

- The accelerator pedal is depressed strongly.
- The steering wheel is turned sharply or abruptly.
- The brake pedal is depressed.

● Intersection right/left turn assistance (pre-collision warning)

When the turn signal lights are not flashing, support for turning left or right at an intersection which targets oncoming vehicles does not work.

Detectable objects	Vehicle speed	Oncoming vehicle speed	Relative speed between your vehicle and object
Vehicles	Approx. 10 to 25 km/h (7 to 15 mph)	Approx. 30 to 55 km/h (20 to 35 mph)	Approx. 40 to 80 km/h (25 to 50 mph)
Pedestrians	Approx. 10 to 25 km/h (7 to 15 mph)	-	Approx. 10 to 25 km/h (7 to 15 mph)

● Intersection right/left turn assistance (pre-collision braking)

When the turn signal lights are not flashing, support for turning left or right at an intersection which targets oncoming vehicles does not work.

Detectable objects	Vehicle speed	Oncoming vehicle speed	Relative speed between your vehicle and object
Vehicles	Approx. 15 to 25 km/h (10 to 15 mph)	Approx. 30 to 45 km/h (20 to 28 mph)	Approx. 45 to 70 km/h (28 to 43 mph)
Pedestrians	Approx. 10 to 25 km/h (7 to 15 mph)	-	Approx. 10 to 25 km/h (7 to 15 mph)

■ Object detection function

The system detects objects based on their size, profile, motion, etc. However, an object may not be detected depending on the surrounding brightness and the motion, posture, and angle of the detected object, preventing the system from operating properly. (→P.217)
The illustration shows an image of detectable objects.

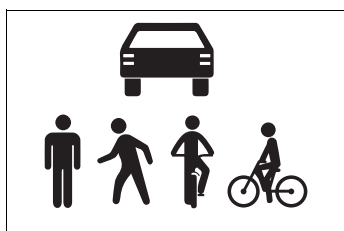

■ Conditions under which the system may operate even if there is no possibility of a collision

- In some situations such as the following, the system may determine that there is a possibility of a frontal collision and operate.
 - When passing a detectable object, etc.
 - When changing lanes while overtaking a detectable object, etc.
 - When approaching a detectable object in an adjacent lane or on the roadside, such as when changing the course of travel or driving on a winding road

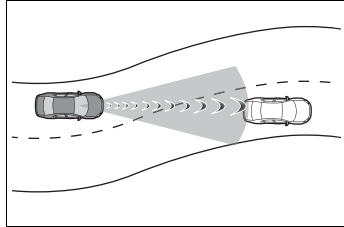

- When rapidly closing on a detectable object, etc.
- When approaching objects on the roadside, such as detectable objects, guardrails, utility poles, trees, or walls
- When there is a detectable object or other object by the roadside at the entrance of a curve

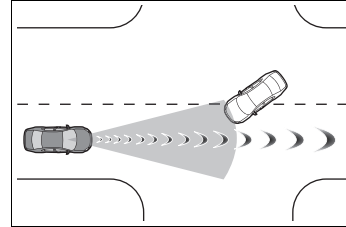

- When a detectable object approaches very close and then stops before entering the path of your vehicle
- If the front of your vehicle is raised or lowered, such as when on an uneven or undulating road surface
- When driving on a road surrounded by a structure, such as in a tunnel or on an iron bridge
- When there is a metal object (man-hole cover, steel plate, etc.), steps, or a protrusion in front of your vehicle
- When passing under an object (road sign, billboard, etc.)

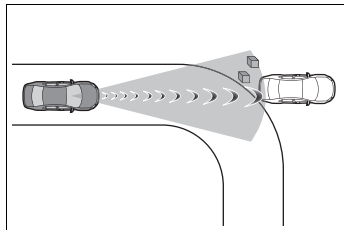

- When there are patterns or paint in front of your vehicle that may be mistaken for a detectable object
- When the front of your vehicle is hit by water, snow, dust, etc.
- When overtaking a detectable object that is changing lanes or making a right/left turn

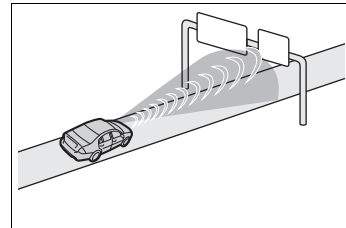

- When approaching an electric toll gate barrier, parking area barrier, or other barrier that opens and closes
- When using an automatic car wash
- When driving through or under objects that may contact your vehicle, such as thick grass, tree branches, or a banner

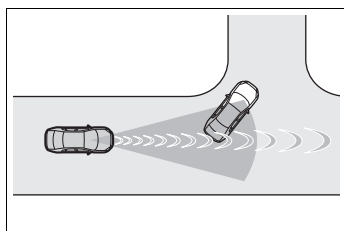

- When passing a detectable object in an oncoming lane that is stopped to make a right/left turn

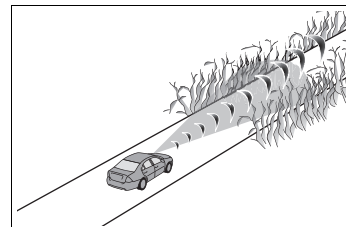

- When driving through steam or smoke
- When driving near an object that

- reflects radio waves, such as a large truck or guardrail
- When driving near a TV tower, broadcasting station, electric power plant, radar equipped vehicles, etc., or other location where strong radio waves or electrical noise may be present
- When there are many things which can reflect the radio waves of the radar in the vicinity (tunnels, truss bridges, gravel roads, snow covered road that have tracks, etc.)
- While making a right/left turn, when an oncoming vehicle or a crossing pedestrian has already exited the path of your vehicle
- While making a right/left turn, closely in front of an oncoming vehicle or a crossing pedestrian
- While making a right/left turn, when an oncoming vehicle or a crossing pedestrian stops before entering the path of your vehicle
- While making a right/left turn, when an oncoming vehicle turns right/left in front of your vehicle

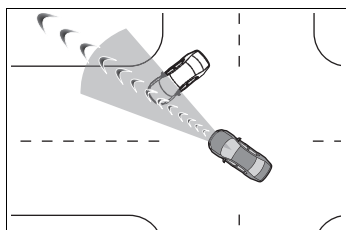

- While steering into the direction of oncoming traffic
- Situations in which the system may not operate properly**
- In some situations such as the following, an object may not be detected by the radar sensor and front camera, preventing the system from operating properly:
 - When a detectable object is approaching your vehicle
 - When your vehicle or a detectable object is wobbling
 - If a detectable object makes an abrupt maneuver (such as sudden swerving, acceleration or deceleration)

- When your vehicle approaches a detectable object rapidly
- When a detectable object is not directly in front of your vehicle

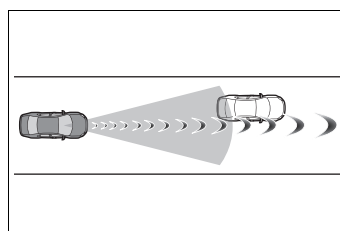

- When a detectable object is near a wall, fence, guardrail, manhole cover, vehicle, steel plate on the road, etc.
- When a detectable object is under a structure
- When part of a detectable object is hidden by an object, such as large baggage, an umbrella, or guardrail
- When there are many things which can reflect the radio waves of the radar in the vicinity (tunnels, truss bridges, gravel roads, snow covered road that have tracks, etc.)
- When there is an effect on the radio waves to the radar that is installed on another vehicle
- When multiple detectable objects are close together
- If the sun or other light is shining directly on a detectable object
- When a detectable object is a shade of white and looks extremely bright
- When a detectable object appears to be nearly the same color or brightness as its surroundings
- If a detectable object cuts or suddenly emerges in front of your vehicle
- When the front of your vehicle is hit by water, snow, dust, etc.
- When a very bright light ahead, such as the sun or the headlights of oncoming traffic, shines directly into the front camera
- When approaching the side or front of a vehicle ahead
- If a vehicle ahead is a motorcycle
- If a vehicle ahead is narrow, such as a personal mobility vehicle
- If a preceding vehicle has a small rear

- end, such as an unloaded truck
- If a preceding vehicle has a low rear end, such as a low bed trailer

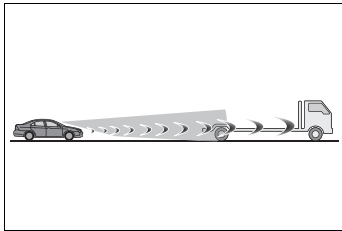

- If a vehicle ahead has extremely high ground clearance

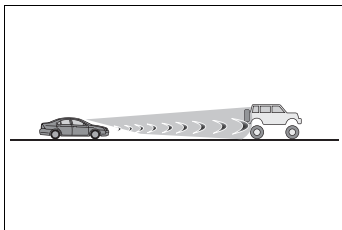

- If a vehicle ahead is carrying a load which protrudes past its rear bumper
- If a vehicle ahead is irregularly shaped, such as a tractor or side car
- If a vehicle ahead is a child sized bicycle, a bicycle that is carrying a large load, a bicycle ridden by more than one person, or a uniquely shaped bicycle (bicycle with a child seat, tandem bicycle, etc.)
- If a pedestrian/or the riding height of a bicyclist ahead is shorter than approximately 1 m (3.2 ft.) or taller than approximately 2 m (6.5 ft.)
- If a pedestrian/bicyclist is wearing oversized clothing (a rain coat, long skirt, etc.), making their silhouette obscure
- If a pedestrian is bending forward or squatting or bicyclist is bending forward
- If a pedestrian/bicyclist is moving fast
- If a pedestrian is pushing a stroller, wheelchair, bicycle or other vehicle
- When driving in inclement weather such as heavy rain, fog, snow or a sandstorm
- When driving through steam or smoke

- When the surrounding area is dim, such as at dawn or dusk, or while at night or in a tunnel, making a detectable object appear to be nearly the same color as its surroundings
- When driving in a place where the surrounding brightness changes suddenly, such as at the entrance or exit of a tunnel
- After the hybrid system has started the vehicle has not been driven for a certain amount of time
- While making a left/right turn and for a few seconds after making a left/right turn
- While driving on a curve and for a few seconds after driving on a curve
- If your vehicle is skidding
- If the front of the vehicle is raised or lowered

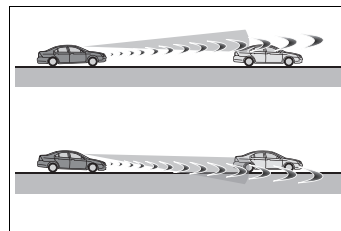

- If the wheels are misaligned
- If a wiper blade is blocking the front camera
- The vehicle is being driven at extremely high speeds
- When driving on a hill
- If the radar sensor or front camera is misaligned
- When driving in a traffic lane separated by more than one lane where oncoming vehicles are driving while making a right/left turn
- When largely out of place with the opposite facing targeted oncoming vehicle during a right/left turn

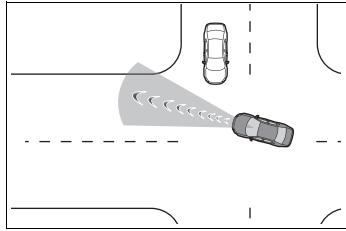

- While making a right/left turn, when a pedestrian approaches from behind or side of your vehicle

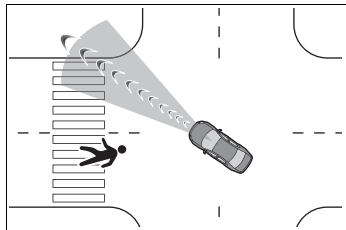

- In addition to the above, in some situations, such as the following, the emergency steering assist may not operate.
- When the white (yellow) lane lines are difficult to see, such as when they are faint, diverging/merging, or a shadow is cast upon them
- When the lane is wider or narrower than normal
- When there is a light and dark pattern on the road surface, such as due to road repairs
- When a pedestrian is detected near the centerline of the vehicle
- When the target is too close
- When there is insufficient safe or unobstructed space for the vehicle to be steered into
- If oncoming vehicle is present
- If VSC function is operating
- In some situations such as the following, sufficient braking force or steering force may not be obtained, preventing the system from performing properly:
 - If the braking functions cannot operate to their full extent, such as when the brake parts are extremely cold, extremely hot, or wet
 - If the vehicle is not properly main-

tained (brakes or tires are excessively worn, improper tire inflation pressure, etc.)

- When the vehicle is being driven on a gravel road or other slippery surface
- When the road surface has deep wheel tracks
- When driving on a hill road
- When driving on a road that inclines to the left or right

■ **If VSC is disabled**

- If VSC is disabled (→P.278), the pre-collision brake assist and pre-collision braking functions are also disabled.
- The PCS warning light will turn on and “VSC Turned OFF Pre-Collision Brake System Unavailable” will be displayed on the multi-information display.

LTA (Lane Tracing Assist)*

*: If equipped

Summary of functions

While driving on a road with clear white (yellow) lane lines, the LTA system warns the driver if the vehicle may deviate from the current lane or course*, and also can slightly operate the steering wheel to help avoid deviation from the lane or course*. Also, while the dynamic radar cruise control with full-speed range is operating, this system will operate the steering wheel to maintain the vehicle's lane position.

The LTA system recognizes white (yellow) lane lines or a course* using the front camera. Additionally, it detects preceding vehicles using the front camera and radar.

*: Boundary between asphalt and the side of the road, such as grass, soil, or a curb

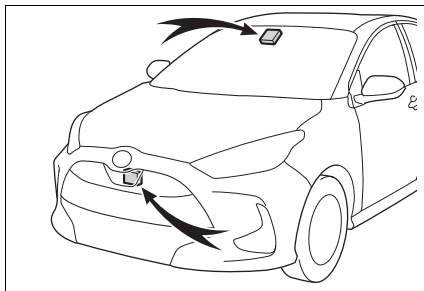

! WARNING

■ Before using LTA system

- Do not rely solely upon the LTA system. The LTA system does not automatically drive the vehicle or reduce the amount of attention that must be paid to the area in front of the vehicle. The driver must always assume full responsibility for driving safely by paying careful attention to the surrounding conditions and operating the steering wheel to correct the path of the vehicle. Also, the driver must take adequate breaks when fatigued, such as from driving for a long period of time.
- Failure to perform appropriate driving operations and pay careful attention may lead to an accident, resulting in death or serious injury.

■ Situations unsuitable for LTA system

In the following situations, use the LTA switch to turn the system off. Failure to do so may lead to an accident, resulting in death or serious injury.

- Vehicle is driven on a road surface which is slippery due to rainy weather, fallen snow, freezing, etc.
- Vehicle is driven on a snow-covered road.
- White (yellow) lines are difficult to see due to rain, snow, fog, dust, etc.
- Vehicle is driven in a temporary lane or restricted lane due to construction work.
- Vehicle is driven in a construction zone.
- A spare tire, tire chains, etc., are equipped.
- When the tires have been excessively worn, or when the tire inflation pressure is low.

⚠ WARNING

- When your vehicle is towing a trailer (vehicles with towing packages) or during emergency towing

■ **Preventing LTA system malfunctions and operations performed by mistake**

- Do not modify the headlights or place stickers, etc., on the surface of the lights.
- Do not modify the suspension, etc. If the suspension, etc., needs to be replaced, contact any authorized Toyota retailer or Toyota authorized repairer, or any reliable repairer.
- Do not install or place anything on the hood or grille. Also, do not install a grille guard (bull bars, kangaroo bar, etc.).
- If your windshield needs repairs, contact any authorized Toyota retailer or Toyota authorized repairer, or any reliable repairer.

■ **Conditions in which functions may not operate properly**

In the following situations, the functions may not operate properly and the vehicle may depart from its lane. Drive safely by always paying careful attention to your surroundings and operate the steering wheel to correct the path of the vehicle without relying solely on the functions.

- When the follow-up cruising display is displayed (→P.225) and the preceding vehicle changes lanes. (Your vehicle may follow the preceding vehicle and also change lanes.)

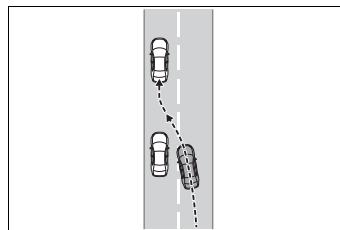

- When the follow-up cruising display is displayed (→P.225) and the preceding vehicle is swaying. (Your vehicle may sway accordingly and depart from the lane.)
- When the follow-up cruising display is displayed (→P.225) and the preceding vehicle departs from its lane. (Your vehicle may follow the preceding vehicle and depart from the lane.)
- When the follow-up cruising display is displayed (→P.225) and the preceding vehicle is being driven extremely close to the left/right lane line. (Your vehicle may follow the preceding vehicle and depart from the lane.)
- Vehicle is being driven around a sharp curve.
- Objects or patterns that could be mistaken for white (yellow) lines are present on the side of the road (guardrails, reflective poles, etc.).

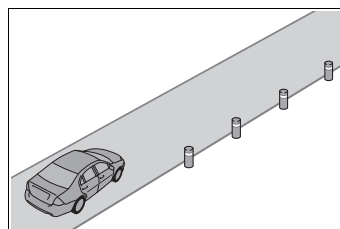

⚠ WARNING

- Vehicle is driven where the road diverges, merges, etc.

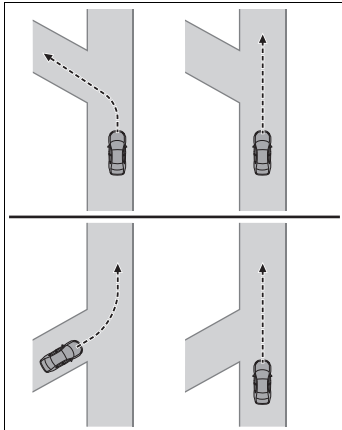

- Repair marks of asphalt, white (yellow) lines, etc., are present due to road repair.

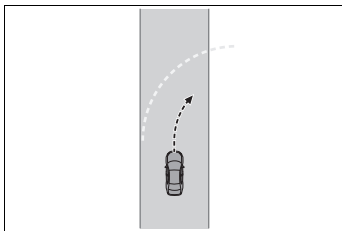

- There are shadows on the road that run parallel with, or cover, the white (yellow) lines.
- The vehicle is driven in an area without white (yellow) lines, such as in front of a tollgate or checkpoint, or at an intersection, etc.
- The white (yellow) lines are cracked, "Raised pavement marker" or stones are present.
- The white (yellow) lines cannot be seen or are difficult to see due to sand, etc.

- The vehicle is driven on a road surface that is wet due to rain, puddles, etc.
- The traffic lines are yellow (which may be more difficult to recognize than lines that are white).
- The white (yellow) lines cross over a curb, etc.
- The vehicle is driven on a bright surface, such as concrete.
- If the edge of the road is not clear or straight.
- The vehicle is driven on a surface that is bright due to reflected light, etc.
- The vehicle is driven in an area where the brightness changes suddenly, such as at the entrances and exits of tunnels, etc.
- Light from the headlights of an oncoming vehicle, the sun, etc., enters the camera.
- The vehicle is driven on a slope.
- The vehicle is driven on a road which tilts left or right, or a winding road.
- The vehicle is driven on an unpaved or rough road.
- The traffic lane is excessively narrow or wide.
- The vehicle is extremely tilted due to carrying heavy luggage or having improper tire pressure.
- The distance to the preceding vehicle is extremely short.
- The vehicle is moving up and down a large amount due to road conditions during driving (poor roads or road seams).

⚠ WARNING

- When driving in a tunnel or at night with the headlights off or when a headlight is dim due to its lens being dirty or it being misaligned.
- The vehicle is struck by a cross-wind.
- The vehicle is affected by wind from a vehicle driven in a nearby lane.
- The vehicle has just changed lanes or crossed an intersection.
- Tires which differ by structure, manufacturer, brand or tread pattern are used.
- When tires of a size other than specified are installed.
- Snow tires, etc., are equipped.
- The vehicle is being driven at extremely high speeds.

Functions included in LTA system**■ Lane departure alert function**

When the system determines that the vehicle might depart from its lane or course*, a warning is displayed on the multi-information display, and either a warning buzzer will sound or the steering wheel will vibrate to alert the driver.

When the warning buzzer sounds or the steering wheel vibrates, check the area around your vehicle and carefully operate the steering wheel to move the vehicle back to the center of the lane.

Vehicle with BSM: When the system determines that the vehicle might depart from its lane and that the possi-

bility of a collision with an overtaking vehicle in the adjacent lane is high, the lane departure alert will operate even if the turn signals are operating.

*: Boundary between asphalt and the side of the road, such as grass, soil, or a curb

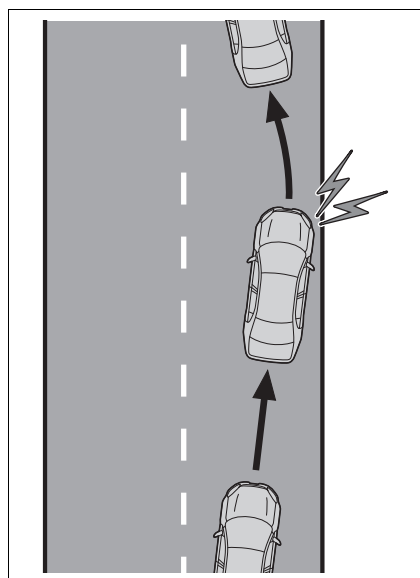
**■ Steering assist function**

When the system determines that the vehicle might depart from its lane or course*, the system provides assistance as necessary by operating the steering wheel in small amounts for a short period of time to keep the vehicle in its lane.

Vehicle with BSM: When the system determines that the vehicle might depart from its lane and that the possibility of a collision with an overtaking vehicle in the adjacent lane is high, the steering assist function will operate even if the turn signals are operating.

*: Boundary between asphalt and the

side of the road, such as grass, soil, or a curb

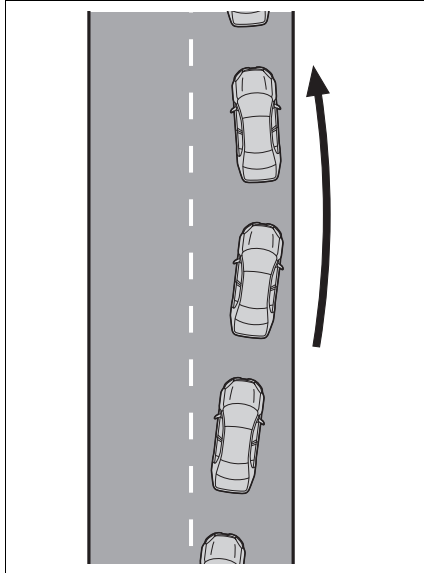

■ **Vehicle sway warning function**

When the vehicle is swaying within a lane, the warning buzzer will sound and a message will be displayed on the multi-information display to alert the driver.

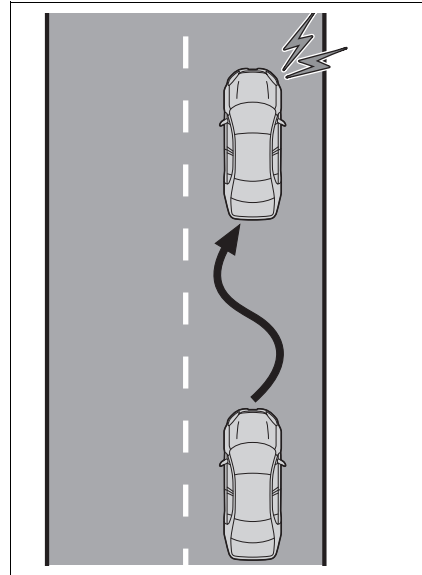

■ **Lane centering function**

This function is linked with dynamic radar cruise control with full-speed range and provides the required assistance by operating the steering wheel to keep the vehicle in its current lane.

When dynamic radar cruise control with full-speed range is not operating, the lane centering function does not operate.

In situations where the white (yellow) lane lines are difficult to see or are not visible, such as when in a traffic jam, this function will operate to help follow a preceding vehicle by monitoring the position of the preceding vehicle.

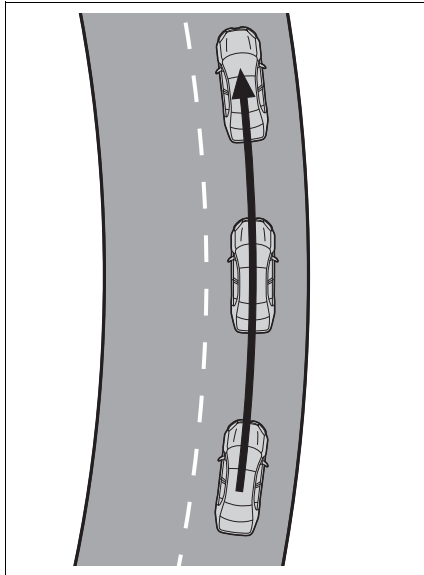

LTA system setting

■ **Turning the lane centering function ON/OFF**

Press the LTA switch.

The lane centering function will change between ON/OFF each time the switch is pressed.

The current setting will be displayed on the multi-information display.

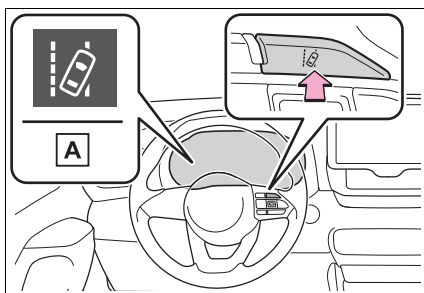

► Lane centering function ON

A “LTA Steering Assist Active Lane Centering Active”

► Lane centering function OFF

A “LTA Steering Assist Active”

■ **Turning the LTA system OFF**

Press and hold the LTA switch

The LTA indicator light turns off when the LTA is turned OFF.

Press the switch again to turn the system on.

The LTA is turned ON each time the power switch is turned to ON.

However, the lane centering function keeps either the ON/OFF state prior to the power switch being turned OFF.

Indications on multi-information display

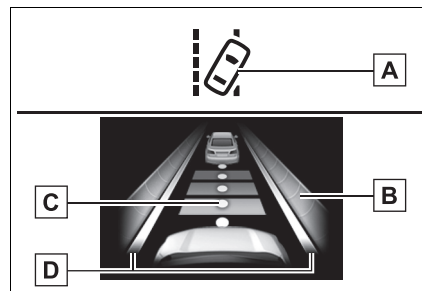

A LTA indicator

The illumination condition of the indicator informs the driver of the system operation status.

Illuminated in white: LTA system is operating.

Illuminated in green: Steering wheel assistance of the steering assist function or lane centering function is operating.

Flashing in orange: Lane departure alert function is operating.

B Operation display of steering

wheel operation support

Displayed when the multi-information display is switched to the driving support system information screen.

Indicates that steering wheel assistance of the steering assist function or lane centering function is operating.

Both outer sides of the lane are displayed: Indicates that steering wheel assist of the lane centering function is operating.

One outer side of the lane is displayed: Indicates that steering wheel assist of the steering assist function is operating.

Both outer sides of the lane are flashing: Alerts the driver that their input is necessary to stay in the center of the lane (lane centering function).

C Follow-up cruising display

Displayed when the multi-information display is switched to the driving support system information screen.

Indicates that steering assist of the lane centering function is operating by monitoring the position of a preceding vehicle.

When the follow-up cruising display is displayed, if the preceding vehicle moves, your vehicle may move in the same way. Always pay careful attention to your surroundings and operate the steering wheel as necessary to correct the path of the vehicle and ensure safety.

D Lane departure alert function display

Displayed when the multi-information display is switched to the driving support system information screen.

▶ Inside of displayed lines is white

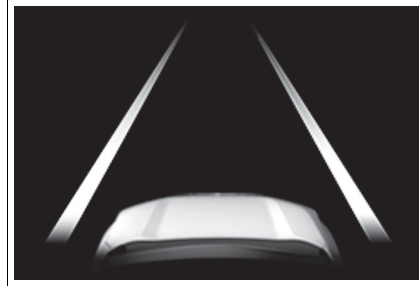

Indicates that the system is recognizing white (yellow) lines or a course*. When the vehicle departs from its lane, the white line displayed on the side the vehicle departs from flashes orange.

▶ Inside of displayed lines is black

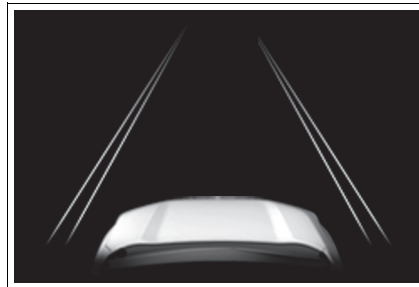

Indicates that the system is not able to recognize white (yellow) lines or a course* or is temporarily canceled.

*: Boundary between asphalt and the side of the road, such as grass, soil, or a curb

■ Operation conditions of each function

- Lane departure alert function
This function operates when all of the following conditions are met.

- LTA is turned on.
- Vehicle speed is approximately 50 km/h (32 mph) or more.*¹
- System recognizes white (yellow) lane lines or a course*². (When a white [yellow] line or course*² is recognized on only one side, the system will operate only for the recognized side.)
- Width of traffic lane is approximately 3 m (9.8 ft.) or more.
- Turn signal lever is not operated.

(Vehicle with BSM: Except when another vehicle is in the lane on the side where the turn signal was operated)

- Vehicle is not being driven around a sharp curve.
- No system malfunctions are detected. (→P.229)

*¹: The function operates even if the vehicle speed is less than approximately 50 km/h (32 mph) when the lane centering function is operating.

*²: Boundary between asphalt and the side of the road, such as grass, soil, or a curb

● Steering assist function

This function operates when all of the following conditions are met in addition to the operation conditions for the lane departure alert function.

- Vehicle is not accelerated or decelerated by a fixed amount or more.
- Steering wheel is not operated with a steering force level suitable for changing lanes.
- ABS, VSC, TRC and PCS are not operating.
- TRC or VSC is not turned off.
- Hands off steering wheel warning is not displayed. (→P.228)

● Vehicle sway warning function

This function operates when all of the following conditions are met.

- Setting for "Sway Warning" in  of the multi-information display is set to

"ON". (→P.431)

- Vehicle speed is approximately 50 km/h (32 mph) or more.
- Width of traffic lane is approximately 3 m (9.8 ft.) or more.
- No system malfunctions are detected. (→P.229)

● Lane centering function

This function operates when all of the following conditions are met.

- LTA is turned on.
- Setting for "Lane Center" in  of the multi-information display is set to "ON" (→P.431)
- This function recognizes white (yellow) lane lines or the position of a preceding vehicle (except when the preceding vehicle is small, such as a motorcycle).
- The dynamic radar cruise control with full-speed range is operating in vehicle-to-vehicle distance control mode.
- Width of traffic lane is approximately 3 to 4 m (10 to 13 ft.).
- Turn signal lever is not operated.
- Vehicle is not being driven around a sharp curve.
- No system malfunctions are detected. (→P.229)
- Vehicle does not accelerate or decelerate by a fixed amount or more.
- Steering wheel is not operated with a steering force level suitable for changing lanes.
- ABS, VSC, TRC and PCS are not operating.
- TRC or VSC is not turned off.
- Hands off steering wheel warning is not displayed. (→P.228)
- The vehicle is being driven in the center of a lane.
- Steering assist function is not operating.

■ Temporary cancelation of functions

- When operation conditions are no longer met, a function may be temporarily canceled. However, when the operation conditions are met again, operation of the function is automati-

cally restored. (→P.226)

- If the operation conditions (→P.226) are no longer met while the lane centering function is operating, the steering wheel may vibrate and the buzzer may sound to indicate that the function has been temporarily canceled. However, if the alert types customization setting is set to steering wheel vibration, the system will notify the driver by vibrating the steering wheel instead of sounding the buzzer.

■ Steering assist function/lane centering function

- Depending on the vehicle speed, lane departure situation, road conditions, etc., the driver may not feel the function is operating or the function may not operate at all.
- The steering control of the function is overridden by the driver's steering wheel operation.
- Do not attempt to test the operation of the steering assist function.

■ Lane departure alert function

- The warning buzzer may be difficult to hear due to external noise, audio playback, etc. Also, it may be difficult to feel steering wheel vibrations due to the road conditions, etc.
- If the edge of the course* is not clear or straight, the lane departure alert function may not operate.
- Vehicle with BSM: It may not be possible for the system to determine if there is a danger of a collision with a vehicle in an adjacent lane.
- Do not attempt to test the operation of the lane departure alert function.

*: Boundary between asphalt and the side of the road, such as grass, soil, or a curb

■ Hands off steering wheel warning

In the following situations, a warning message urging the driver to hold the steering wheel and the symbol shown in

the illustration are displayed on the multi-information display to warn the driver. The warning stops when the system determines that the driver holds the steering wheel. Always keep your hands on the steering wheel when using this system, regardless of warnings.

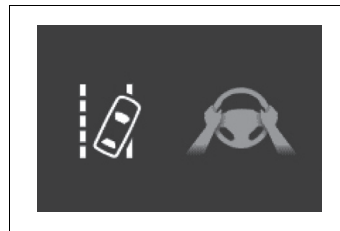

- When the system determines that the driver is driving without holding the steering wheel while the system is operating

If the driver continues to keep their hands off of the steering wheel, the buzzer sounds, the driver is warned and the function is temporarily canceled. This warning also operates in the same way when the driver continuously operates the steering wheel only a small amount.

The buzzer also sounds even if the alert type is set to steering wheel vibration.

- When the system determines that the vehicle may deviate from the lane while driving around a curve while the lane centering function is operating.

Depending on the vehicle condition and road conditions, the warning may not operate. Also, if the system determines that the vehicle is driving around a curve, warnings will occur earlier than during straight-lane driving.

- When the system determines that the driver is driving without holding the steering wheel while the steering wheel assist of the steering assist function is operating.

If the driver continues to keep their hands off of the steering wheel and the

steering wheel assist is operating, the buzzer sounds and the driver is warned. Each time the buzzer sounds, the continuing time of the buzzer becomes longer.

The buzzer also sounds even if the alert type is set to steering wheel vibration.

■ Vehicle sway warning function

When the system determines that the vehicle is swaying while the vehicle sway warning function is operating, a buzzer sounds and a warning message urging the driver to rest and the symbol shown in the illustration are simultaneously displayed on the multi-information display.



Depending on the vehicle and road conditions, the warning may not operate.

■ Warning message

If the following warning message is displayed on the multi-information display and the LTA indicator illuminates in orange, follow the appropriate troubleshooting procedure. Also, if a different warning message is displayed, follow the instructions displayed on the screen.

● “LTA Malfunction Visit Your Dealer”

The system may not be operating properly. Have the vehicle inspected by any authorized Toyota retailer or Toyota authorized repairer, or any reliable repairer.

● “LTA Unavailable”

The system is temporarily canceled due to a malfunction in a sensor other than the front camera. Turn the LTA system off, wait for a little while, and then turn

the LTA system back on.

● “LTA Unavailable at Current Speed”

The function cannot be used as the vehicle speed exceeds the LTA operation range. Drive slower.

■ Customization

Function settings can be changed. (Customizable features:→P.431)

Dynamic radar cruise control with full-speed range*

*: If equipped

Summary of functions

In vehicle-to-vehicle distance control mode, the vehicle automatically accelerates, decelerates and stops to match the speed changes of the preceding vehicle even if the accelerator pedal is not depressed. In constant speed control mode, the vehicle runs at a fixed speed. Use the dynamic radar cruise control with full-speed range on free-ways and highways.

- Vehicle-to-vehicle distance control mode (→P.233)
- Constant speed control mode (→P.237)

System components

■ Meter display

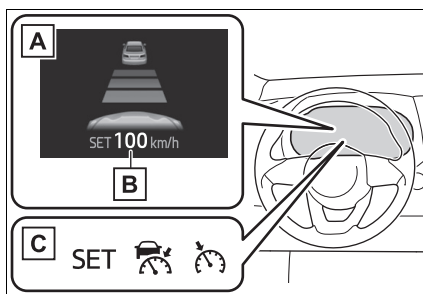

- A Multi-information display
- B Set speed

C Indicators

■ Operation switches

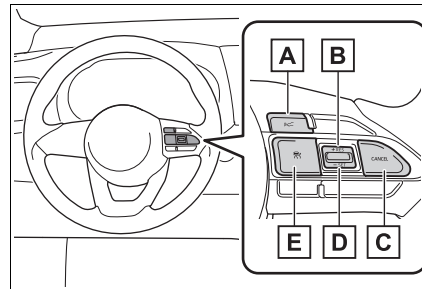

- A Vehicle-to-vehicle distance switch
- B "+RES" switch
- C Cancel switch
- D "-SET" switch
- E Cruise control main switch

WARNING

■ Before using dynamic radar cruise control with full-speed range

- Driving safely is the sole responsibility of the driver. Do not rely solely on the system, and drive safely by always paying careful attention to your surroundings.
- The dynamic radar cruise control with full-speed range provides driving assistance to reduce the driver's burden. However, there are limitations to the assistance provided.

Read the following conditions carefully. Do not overly rely on this system and always drive carefully.

- When the sensor may not be correctly detecting the vehicle ahead: →P.240

⚠ WARNING

- Conditions under which the vehicle-to-vehicle distance control mode may not function correctly: →P.241

- Set the speed appropriately depending on the speed limit, traffic flow, road conditions, weather conditions, etc. The driver is responsible for checking the set speed.

- Even when the system is functioning normally, the condition of the preceding vehicle as detected by the system may differ from the condition observed by the driver. Therefore, the driver must always remain alert, assess the danger of each situation and drive safely. Relying solely on this system or assuming the system ensures safety while driving can lead to an accident, resulting in death or serious injury.

- Switch the dynamic radar cruise control with full-speed range setting to off, using the cruise control main switch when not in use.

■ **Cautions regarding the driving assist systems**

Observe the following precautions, as there are limitations to the assistance provided by the system. Failure to do so may cause an accident resulting in death or serious injury.

- Assisting the driver to measure following distance

The dynamic radar cruise control with full-speed range is only intended to help the driver in determining the following distance between the driver's own vehicle and a designated vehicle traveling ahead. It is not a mechanism that allows careless or inattentive driving, and it is not a system that can assist the driver in low-visibility conditions.

It is still necessary for driver to pay close attention to the vehicle's surroundings.

- Assisting the driver to judge proper following distance

The dynamic radar cruise control with full-speed range determines whether the following distance between the driver's own vehicle and a designated vehicle traveling ahead is within a set range. It is not capable of making any other type of judgement. Therefore, it is absolutely necessary for the driver to remain vigilant and to determine whether or not there is a possibility of danger in any given situation.

- Assisting the driver to operate the vehicle

The dynamic radar cruise control with full-speed range does not include functions which will prevent or avoid collisions with vehicles ahead of your vehicle. Therefore, if there is ever any possibility of danger, the driver must take immediate and direct control of the vehicle and act appropriately in order to ensure the safety of all involved.

**WARNING****■ Situations unsuitable for dynamic radar cruise control with full-speed range**

Do not use dynamic radar cruise control with full-speed range in any of the following situations. Doing so may result in inappropriate speed control and could cause an accident resulting in death or serious injury.

- Roads where there are pedestrians, cyclists, etc.
- In heavy traffic
- On roads with sharp bends
- On winding roads
- On slippery roads, such as those covered with rain, ice or snow
- On steep downhills, or where there are sudden changes between sharp up and down gradients

Vehicle speed may exceed the set speed when driving down a steep hill.

- At entrances to freeways and highways
- When weather conditions are bad enough that they may prevent the sensors from detecting correctly (fog, snow, sandstorm, heavy rain, etc.)
- When there is rain, snow, etc., on the front surface of the radar or front camera
- In traffic conditions that require frequent repeated acceleration and deceleration
- When your vehicle is towing a trailer (vehicles with towing packages) or during emergency towing
- When an approach warning buzzer is heard often

Driving in vehicle-to-vehicle distance control mode

This mode employs a radar to detect the presence of vehicles up to approximately 100 m (328 ft.) ahead, determines the current vehicle-to-vehicle following distance, and operates to maintain a suitable following distance from the vehicle ahead. The desired vehicle-to-vehicle distance can also be set by operating the vehicle-to-vehicle distance switch.

When driving on downhill slopes, the vehicle-to-vehicle distance may become shorter.

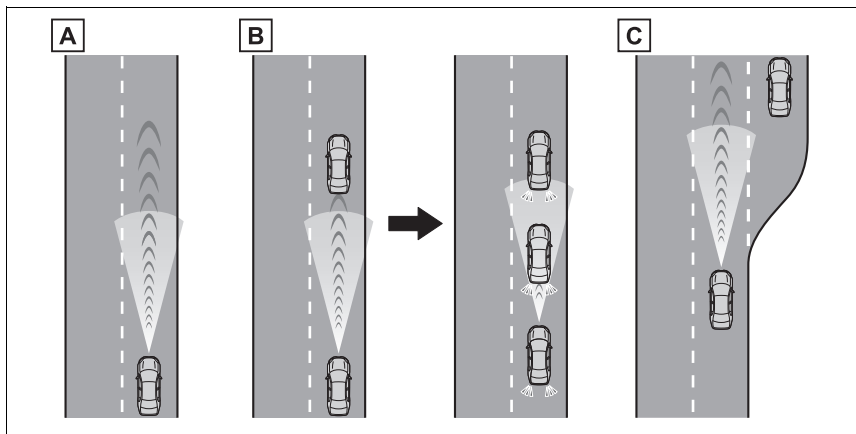
**A** Example of constant speed cruising

When there are no vehicles ahead

The vehicle travels at the speed set by the driver.

B Example of deceleration cruising and follow-up cruising

When a preceding vehicle driving slower than the set speed appears

When a vehicle is detected running ahead of you, the system automatically decelerates your vehicle. When a greater reduction in vehicle speed is necessary, the system applies the brakes (the stop lights will come on at this time). The system will respond to changes in the speed of the vehicle ahead in order to maintain the vehicle-to-vehicle distance set by the driver. Approach warning warns you when the system cannot decelerate sufficiently to prevent your vehicle from closing in on the vehicle ahead.

When the vehicle ahead of you stops, your vehicle will also stop (vehicle is stopped by system control). After the vehicle ahead starts off, pressing the “+RES” switch or depressing the accelerator pedal (start-off operation) will resume follow-up cruising. If the start-off operation is not performed, system control continues to keep your vehicle stopped.

234 4-5. Using the driving support systems

When the turn signal lever is operated and your vehicle moves to an overtaking lane while driving at 80 km/h (50 mph) or more, the vehicle will accelerate to help to overtake a passing vehicle.

The system's identification of what is an overtaking lane may be determined solely based on the location of the steering wheel in the vehicle (left side driver position versus right side driver position.) If the vehicle is driven to a region where the overtaking lane is on a different side from where the vehicle is normally driven, the vehicle may accelerate when the turn signal lever is operated in the opposite direction to the overtaking lane (e.g., if the driver normally operates the vehicle in a region where the overtaking lane is to the right but then drives to a region where the overtaking lane is to the left, the vehicle may accelerate when the right turn signal is activated).

C Example of acceleration

When there are no longer any preceding vehicles driving slower than the set speed

The system accelerates until the set speed is reached. The system then returns to constant speed cruising.

Setting the vehicle speed (vehicle-to-vehicle distance control mode)

- 1 Press the cruise control main switch to activate the cruise control.

Dynamic radar cruise control indicator will come on and a message will be displayed on the multi-information display. Press the switch again to deactivate the cruise control.

If the cruise control main switch is pressed and held for 1.5 seconds or more, the system turns on in constant

speed control mode. (→P.237)

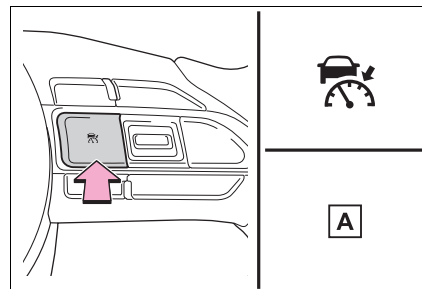

A "Radar Ready"

- 2 Accelerate or decelerate, with accelerator pedal operation, to the desired vehicle speed (at or above approximately 30 km/h [20 mph]) and press the "-SET" switch to set the speed.

Cruise control "SET" indicator will come on.

The vehicle speed at the moment the switch is released becomes the set

speed.

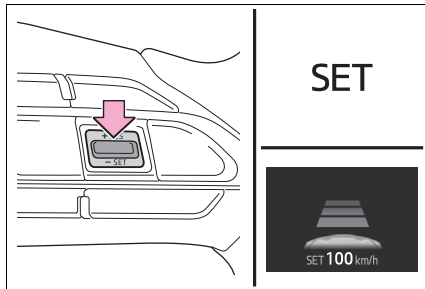

Adjusting the set speed

■ Adjusting the set speed by the switch

To change the set speed, press the “+RES” or “-SET” switch until the desired set speed is displayed.

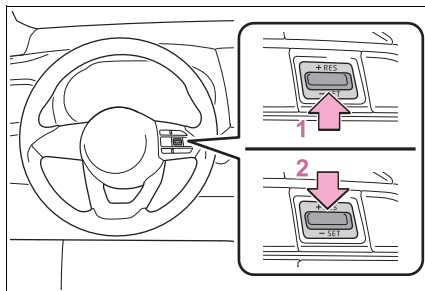

- 1** Increases the speed (Except when the vehicle has been stopped by system control in vehicle-to-vehicle distance control mode)
- 2** Decreases the speed

Fine adjustment: Press the switch.

Large adjustment: Press and hold the switch to change the speed, and release when the desired speed is reached.

In the vehicle-to-vehicle distance control mode, the set speed will be

increased or decreased as follows:

Fine adjustment: By 1 km/h (0.6 mph)^{*1} or 1 mph (1.6 km/h)^{*2} each time the switch is pressed

Large adjustment: Increases or decreases in 5 km/h (3.1 mph)^{*1} or 5 mph (8 km/h)^{*2} increments for as long as the switch is held

In the constant speed control mode (→P.237), the set speed will be increased or decreased as follows:

Fine adjustment: By 1 km/h (0.6 mph)^{*1} or 1 mph (1.6 km/h)^{*2} each time the switch is pressed

Large adjustment: The speed will continue to change while the switch is held.

^{*1}: When the set speed is shown in “km/h”

^{*2}: When the set speed is shown in “MPH”

■ Increasing the set speed by the accelerator pedal

- 1** Accelerate with accelerator pedal operation to the desired vehicle speed
- 2** Press the “-SET” switch

Changing the vehicle-to-vehicle distance (vehicle-to-vehicle distance control mode)

Pressing the switch changes the vehicle-to-vehicle distance as follows:

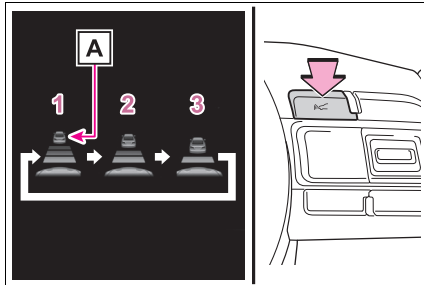

- 1 Long
- 2 Medium
- 3 Short

If a vehicle is running ahead of you, the preceding vehicle mark **A** will also be displayed.

Vehicle-to-vehicle distance settings (vehicle-to-vehicle distance control mode)

Select a distance from the table below. Note that the distances shown correspond to a vehicle speed of 80 km/h (50 mph). Vehicle-to-vehicle distance increases/decreases in accordance with vehicle speed. When the vehicle is stopped by system control, the vehicle stops at a certain vehicle-to-vehicle distance depending on the situation.

Distance options	Vehicle-to-vehicle distance
Long	Approximately 50 m (160 ft.)

Distance options	Vehicle-to-vehicle distance
Medium	Approximately 40 m (130 ft.)
Short	Approximately 30 m (100 ft.)

Resuming follow-up cruising when the vehicle has been stopped by system control (vehicle-to-vehicle distance control mode)

After the vehicle ahead of you starts off, press the “+RES” switch.

Your vehicle will also resume follow-up cruising if the accelerator pedal is depressed after the vehicle ahead of you starts off.

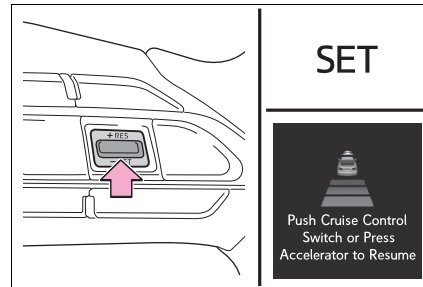

Canceling and resuming the speed control

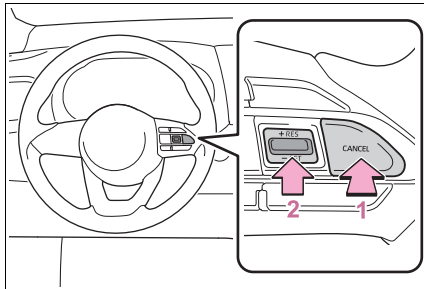

- 1 Pressing the cancel switch cancels the speed control.

The speed control is also canceled when the brake pedal is depressed. (When the vehicle has been stopped by system control, depressing the brake pedal does not cancel the setting.)

- 2 Pressing the “+RES” switch resumes the cruise control and returns vehicle speed to the set speed.

Approach warning (vehicle-to-vehicle distance control mode)

When your vehicle is too close to a vehicle ahead, and sufficient automatic deceleration via the cruise control is not possible, the display will flash and the buzzer will sound to alert the driver. An example of this would be if another driver cuts in front of you while you are following a vehicle. Depress the brake pedal to ensure an appropriate vehicle-to-vehicle distance.

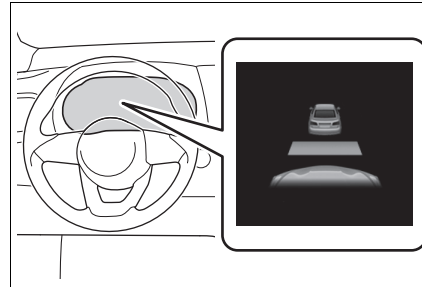

Warnings may not occur when

In the following instances, warnings may not occur even when the vehicle-to-vehicle distance is small.

- When the speed of the preceding vehicle matches or exceeds your vehicle speed
- When the preceding vehicle is traveling at an extremely slow speed
- Immediately after the cruise control speed was set
- When depressing the accelerator pedal

Selecting constant speed control mode

When constant speed control mode is selected, your vehicle will maintain a set speed without controlling the vehicle-to-vehicle distance. Select this mode only when vehicle-to-vehicle distance control mode does not function correctly due to a dirty radar, etc.

- 1 With the cruise control off, press and hold the cruise control main switch for 1.5 seconds or more.

Immediately after the switch is pressed, the dynamic radar cruise control indicator will come on. Afterwards, it switches to the cruise control indicator.

Switching to constant speed control mode is only possible when operating the switch with the cruise control off.

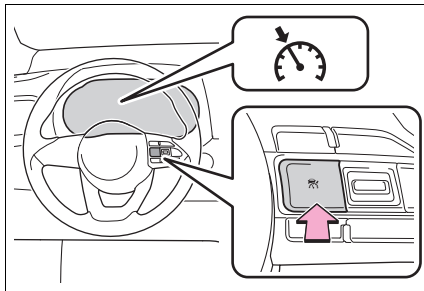

- 2 Accelerate or decelerate, with accelerator pedal operation, to the desired vehicle speed (at or above approximately 30 km/h [20 mph]) and press the “-SET” switch to set the speed.

Cruise control “SET” indicator will come on.

The vehicle speed at the moment the switch is released becomes the set speed.

Adjusting the speed setting: →P.235

Canceling and resuming the speed setting: →P.237

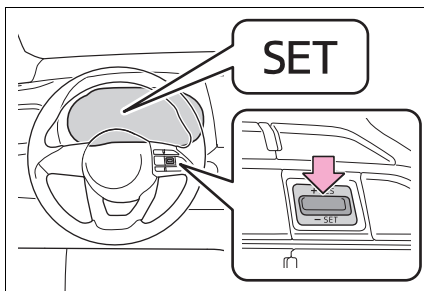

Dynamic Radar Cruise Control with Road Sign Assist (if equipped)

When this function is enabled and the system is operating in vehicle-to-vehicle distance control mode (→P.233), when a speed limit sign is detected, the recognized speed limit will be displayed with an up/down arrow. The set speed can be increased/reduced to the recognized speed limit by pressing and holding the “+RES”/“-SET” switch.

- When the current set speed is lower than the recognized speed limit

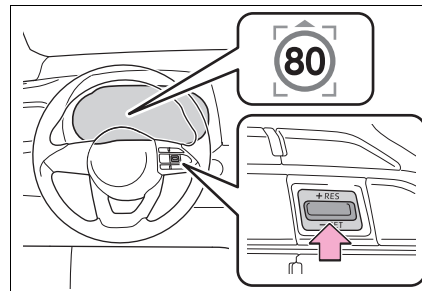

Press and hold the “+RES” switch.

- When the current set speed is higher than the recognized speed limit

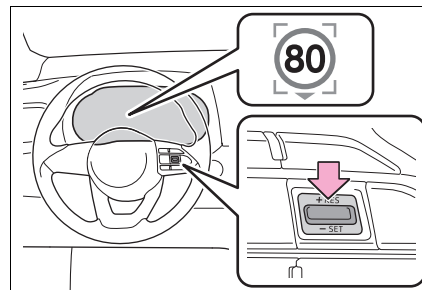

Press and hold the “-SET” switch.

Enabling/Disabling the Dynamic Radar Cruise Control with Road Sign Assist (if equipped)

Dynamic Radar Cruise Control with Road Sign Assist can be

enabled/disabled in  on the

multi-information display. (→P.431)

When the Dynamic Radar Cruise Control with Road Sign Assist is operating, while driving down a hill, the vehicle speed may exceed the set speed. In this case, the displayed set vehicle speed will be highlighted and a buzzer will sound to alert the driver.

■ Dynamic radar cruise control with full-speed range can be set when

- The shift lever is in D.
- The desired set speed can be set when the vehicle speed is approximately 30 km/h (20 mph) or more. (However, when the vehicle speed is set while driving at below approximately 30 km/h [20 mph], the set speed will be set to approximately 30 km/h [20 mph].)

■ Accelerating after setting the vehicle speed

The vehicle can accelerate by operating the accelerator pedal. After accelerating, the set speed resumes. However, during vehicle-to-vehicle distance control mode, the vehicle speed may decrease below the set speed in order to maintain the distance to the preceding vehicle.

■ When the vehicle stops while follow-up cruising

- Pressing the “+RES” switch while the vehicle ahead stops will resume follow-up cruising if the vehicle ahead starts off within approximately 3 seconds after the switch is pressed.
- If the vehicle ahead starts off within 3 seconds after your vehicle stops, follow-up cruising will be resumed.

■ Automatic cancelation of vehicle-to-vehicle distance control mode

Vehicle-to-vehicle distance control mode is automatically canceled in the following situations.

- VSC is activated.
- TRC is activated for a period of time.
- When the VSC or TRC system is turned off.
- The sensor cannot detect correctly because it is covered in some way.
- When the brake control or output restriction control of a driving support system operates. (For example: Pre-Collision System, Drive-Start Control)
- The parking brake is operated.
- The vehicle is stopped by system control on a steep incline.
- The following are detected when the vehicle has been stopped by system control:
 - The driver is not wearing a seat belt.
 - The driver's door is opened.
 - The vehicle has been stopped for about 3 minutes

If vehicle-to-vehicle distance control mode is automatically canceled for any reasons other than the above, there may be a malfunction in the system. Contact any authorized Toyota retailer or Toyota authorized repairer, or any reliable repairer.

■ Automatic cancelation of constant speed control mode

Constant speed control mode is automatically canceled in the following situations:

- Actual vehicle speed is more than approximately 16 km/h (10 mph) below the set vehicle speed.
- Actual vehicle speed falls below approximately 30 km/h (20 mph).
- VSC is activated.
- TRC is activated for a period of time.
- When the VSC or TRC system is turned off.
- When the brake control or output restriction control of a driving support system operates. (For example: Pre-Collision System, Drive-Start Control)
- The parking brake is operated.

If constant speed control mode is automatically canceled for any reasons other than the above, there may be a malfunction in the system. Contact any authorized Toyota retailer or Toyota authorized repairer, or any reliable repairer.

■ **The Dynamic Radar Cruise Control with Road Sign Assist may not operate properly when (if equipped)**

As the Dynamic Radar Cruise Control with Road Sign Assist may not operate properly in conditions in which RSA may not operate or detect correctly (→P.247), when using this function, make sure to check the speed limit sign displayed.

In the following situations, the set speed may not be changed to the recognized speed limit by pressing and holding the “+RES”/“-SET” switch.

- If speed limit information is not available
- When the recognized speed limit is the same as the set speed
- When the recognized speed limit is outside of the speed range that the dynamic radar cruise control system can operate

■ **Brake operation**

A brake operation sound may be heard and the brake pedal response may

change, but these are not malfunctions.

■ **Warning messages and buzzers for dynamic radar cruise control with full-speed range**

Warning messages and buzzers are used to indicate a system malfunction or to inform the driver of the need for caution while driving. If a warning message is shown on the multi-information display, read the message and follow the instructions. (→P.207, 383)

■ **When the sensor may not be correctly detecting the vehicle ahead**

In the case of the following and depending on the conditions, operate the brake pedal when deceleration of the system is insufficient or operate the accelerator pedal when acceleration is required.

As the sensor may not be able to correctly detect these types of vehicles, the approach warning (→P.237) may not be activated.

- Vehicles that cut in suddenly
- Vehicles traveling at low speeds
- Vehicles that are not moving in the same lane
- Vehicles with small rear ends (trailers with no load on board, etc.)

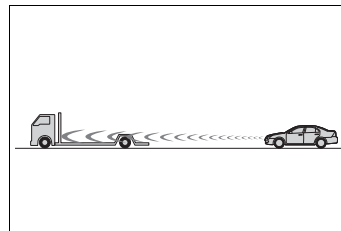

- Motorcycles traveling in the same lane
- When water or snow thrown up by the surrounding vehicles hinders the detecting of the sensor
- When your vehicle is pointing upwards (caused by a heavy load in the luggage compartment, etc.)

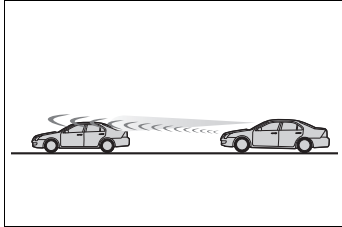

- Preceding vehicle has an extremely high ground clearance

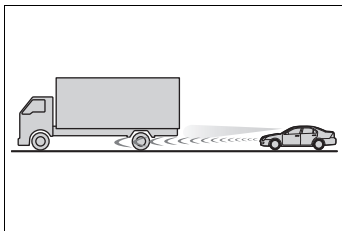

■ **Conditions under which the vehicle-to-vehicle distance control mode may not function correctly**

In the case of the following conditions, operate the brake pedal (or accelerator pedal, depending on the situation) as necessary.

As the sensor may not be able to correctly detect vehicles ahead, the system may not operate properly.

- When the road curves or when the lanes are narrow

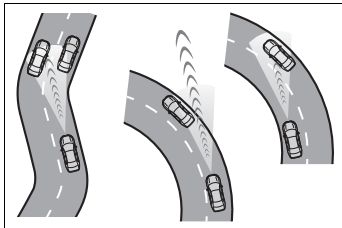

- When steering wheel operation or your position in the lane is unstable

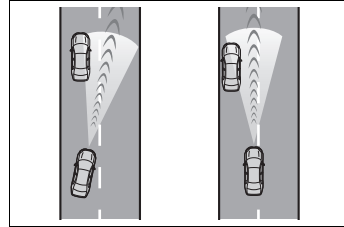

- When the vehicle ahead of you decelerates suddenly
- When driving on a road surrounded by a structure, such as in a tunnel or on a bridge

Speed limiter*

*: If equipped

A desired maximum speed can be set using the speed limiter switch. The speed limiter prevents vehicle speed from exceeding the set speed.

System components

Meter display

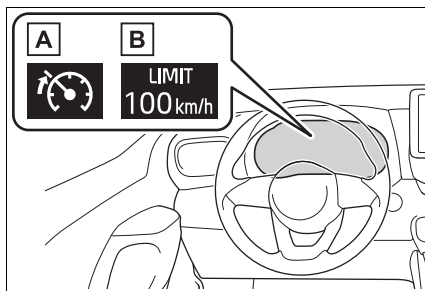

A Indicators

B Set speed

Operation switches

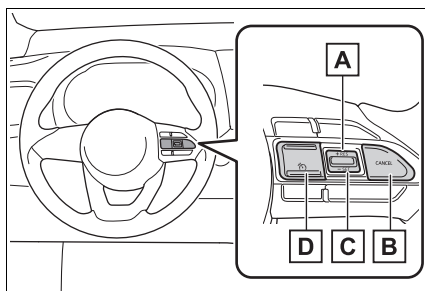

A "+RES" switch

B Cancel switch

C "-SET" switch

D Speed limiter main switch

Setting the vehicle speed

- 1 Press the speed limiter main switch to activate the speed limiter.

Speed limiter indicator will come on. Press the switch again to deactivate the speed limiter.

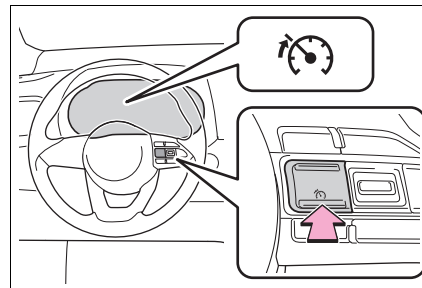

- 2 Accelerate or decelerate the vehicle to the desired speed, and press the "-SET" switch to set the desired maximum speed.

The set speed is displayed on the multi-information display.

If the switch is pressed while the vehicle speed is below 30 km/h (20 mph), the set speed will be 30 km/h (20 mph).

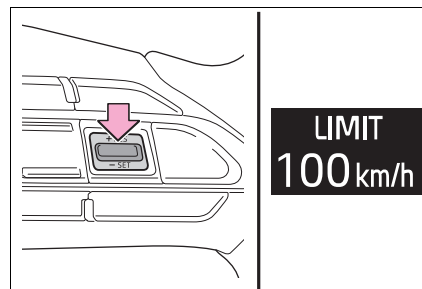

Adjusting the set speed

To change the set speed, press the “+RES” or “-SET” switch until the desired set speed is obtained.

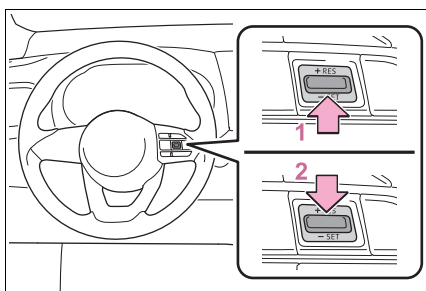

- 1 Increases the speed
- 2 Decreases the speed

Fine adjustment: Press the switch in the desired direction.

Large adjustment: Press and hold switch.

The set speed will be increased or decreased as follows:

Fine adjustment: By 1 km/h (0.6 mph)^{*1} or 1 mph (1.6 km/h)^{*2} each time the switch is pressed

Large adjustment: Increases or decreases in 5 km/h (3.1 mph)^{*1} or 5 mph (8 km/h)^{*2} increments for as long as the switch is held

^{*1}: When the set speed is shown in “km/h”

^{*2}: When the set speed is shown in “MPH”

Canceling and resuming the constant speed control

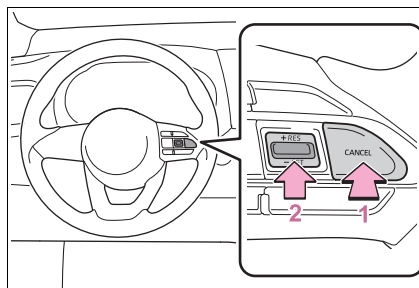

- 1 Pressing the cancel switch cancels the speed limiter.
- 2 Pressing the “+RES” switch resumes the speed limiter.

Exceeding the set speed

In the following situations, the vehicle speed exceeds the set speed and display characters will flash:

- When fully depressing the accelerator pedal
- When driving down a slope

Automatic speed limiter cancellation

The speed limiter is automatically canceled in any of the following situations:

- Cruise control is activated.
- When the VSC or TRC system is turned off by pressing the VSC off switch.

If the warning message for the speed limiter is shown on the multi-information display

Stop the hybrid system and then restart the hybrid system. After restarting the hybrid system, set the speed limiter. If the speed limiter cannot be set, there may be a malfunction in the speed limiter. Have the vehicle inspected by any authorized Toyota retailer or Toyota authorized repairer, or any reliable repairer.

⚠ WARNING

■ **To avoid operating the speed limiter by mistake**

Switch the speed limiter off using the speed limiter main switch when not in use.

■ **Situations unsuitable for speed limiter**

Do not use speed limiter in any of the following situations.

Doing so may result in loss of control and could cause an accident resulting in death or serious injury.

- On slippery roads, such as those covered with rain, ice or snow
- On steep hills
- When your vehicle is towing a trailer or during emergency towing

RSA (Road Sign Assist)*

*: If equipped

Summary of function

The RSA system recognizes specific road signs using the front camera and/or 7-inch/8-inch display navigation system (when speed limit information is available) to provide information to the driver via the display.

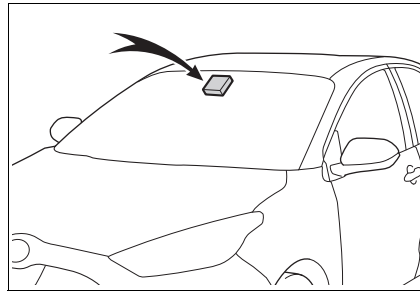

If the system judges that the vehicle is being driven over the speed limit, performing prohibited actions, etc., according to the recognized road signs, it notifies the driver through a visual notification and notification buzzer.

⚠ WARNING

■ **Before using the RSA**

Do not rely solely upon the RSA system. RSA is a system which supports the driver by providing information, but it is not a replacement for a driver's own vision and awareness. Drive safely by always paying careful attention to the traffic rules.

Indication on the multi-information display

When the front camera recognizes a sign and/or information of a sign is available from the 7-inch/8-inch display navigation system, the sign will be displayed on the multi-information display.

- When the driving support system information is selected, a maximum of 3 signs (vertical display) or 2 signs (horizontal display) can be displayed. (→P.103, 109)

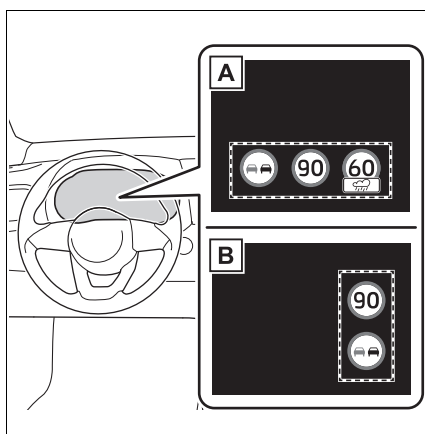

A Vertical display

B Horizontal display

- When a tab other than the driving support system information is selected, the following types of road signs will be displayed. (→P.103, 109)
- Speed limit begins/ends sign
- Speed limit related information sign (Motorway, Expressway, Urban area, Residential area)

- End of prohibition sign
- No-entry sign* (when notification is necessary)
- Speed limit with supplemental sign (Ramp way only)

*: For vehicles with 7-inch/8-inch display navigation system

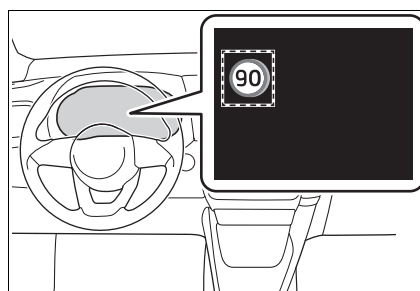

If signs other than speed limit signs are recognized, they will be displayed in an overlapping stack under the current speed limit sign.

Supported types of road signs

The following types of road signs, including electronic signs and blinking signs, are recognized.

A non-official (not meeting the Vienna Convention) or a recently introduced traffic sign may not be recognized.

- Speed limit road signs

 Speed limit begins/Maximum speed zone begins



 Speed limit ends/Maximum speed zone ends

- Speed limit related information*

-  Motorway entrance
-  Motorway exit
-  Expressway entrance
-  Expressway exit
-  Urban area beginning
-  Urban area ending
-  Urban area beginning
-  Urban area ending
-  Residential area beginning
-  Residential area ending

*: Displayed when a sign is recognized but speed limit information for the road is not available from the 7-inch/8-inch display navigation system

● No-overtaking road signs







-  No overtaking begins
-  No overtaking ends

● Other road signs

-  No-entry*
-  End of prohibition
-  Stop

*: For vehicles with 7-inch/8-inch display navigation system

● Speed limit with supplemental mark*¹

-  Wet
-  Rain
-  Ice
-  Supplemental mark exists*²
-  Exit ramp on right*³
-  Exit ramp on left*³
-  Time

*¹: Displayed simultaneously with speed limit

*²: Contents not recognized.

*³: Displayed when system detects driving on ramp way.











Notification function

In the following situations, the RSA system will notify the driver.

- When the vehicle speed exceeds the speed notification threshold of the speed limit sign displayed, the sign display will be emphasized and a buzzer will sound.
- When the RSA system recognizes a no-entry sign and detects that the vehicle has entered a no-entry area based on the map information of the navigation system, the no-entry sign flashes and a buzzer will sound. (For vehicles with 7-inch/8-inch display navigation system)
- If it is detected that your vehicle is overtaking when a no overtaking sign is displayed on the multi-information display, the displayed sign will flash and a buzzer will sound.

Depending on the situation, traffic environment (traffic direction, speed unit) may be detected incorrectly and a notification function may not operate properly.

■ Setting procedure

- 1 Press  /  (vertical display) or  /  (horizontal display) of the meter control switches and select .
- 2 Press  /  (vertical display) or  /  (horizontal display) of the meter control switches and select , then press OK.

■ Automatic turn-off of RSA sign display

One or more signs automatically turn off in the following situations.

- No sign has been recognized for a certain distance.
- The road changes due to a left or right turn, etc.

■ Conditions in which the function may not operate or detect correctly

In the following situations, RSA does not operate normally and may not recognize signs, display the incorrect sign, etc. However, this does not indicate a malfunction.

- The front camera is misaligned due to a strong impact being applied to the sensor, etc.
- Dirt, snow, stickers, etc., are on the windshield near the front camera.
- In inclement weather such as heavy rain, fog, snow or sand storms.
- Light from an oncoming vehicle, the sun, etc., enters the front camera.
- The sign is dirty, faded, tilted or bent.
- The contrast of electronic sign is low.
- All or part of the sign is hidden by the leaves of a tree, a pole, etc.
- The sign is only visible to the front camera for a short amount of time.
- The driving scene (turning, lane change, etc.) is judged incorrectly.
- If a sign not appropriate for the currently traveled lane, but the sign exists directly after a freeway branches, or in an adjacent lane just before merging.
- Stickers are attached to the rear of the preceding vehicle.
- A sign resembling a system compatible sign is recognized.
- Side road speed signs may be detected and displayed (if positioned in sight of the front camera) while the vehicle is traveling on the main road.
- Roundabout exit road speed signs

may be detected and displayed (if positioned in sight of the front camera) while traveling on a roundabout.

- The front of the vehicle is raised or lowered due to the carried load.
- The surrounding brightness is not sufficient or changes suddenly.
- When a sign intended for trucks, etc., is recognized.
- The vehicle is driven in a country with a different direction of traffic.
- The 7-inch/8-inch display navigation system map data is outdated.
- The 7-inch/8-inch display navigation system is not operating.
- The speed information displayed on the meter and on the 7-inch/8-inch display navigation system may be different due to the 7-inch/8-inch display navigation system using map data.

■ **Speed limit sign display**

If the power switch was last turned off while a speed limit sign was displayed on the multi-information display, the same sign displays again when the power switch is turned to ON.

■ **If “RSA Malfunction Visit Your Dealer” is shown**

The system may be malfunctioning. Have the vehicle inspected by any authorized Toyota retailer or Toyota authorized repairer, or any reliable repairer.

■ **Customization**

Some functions can be customized. (Customizable features:→P.431)

BSM (Blind Spot Monitor)*

*: If equipped

The Blind Spot Monitor is a system that uses rear side radar sensors installed on the inner side of the rear bumper on the left and right side to assist the driver in confirming safety when changing lanes.

 **WARNING**

■ **Cautions regarding the use of the system**

The driver is solely responsible for safe driving. Always drive safely, taking care to observe your surroundings.

The Blind Spot Monitor is a supplementary function which alerts the driver that a vehicle is in a blind spot of the outside rear view mirrors or is approaching rapidly from behind into a blind spot. Do not overly rely on the Blind Spot Monitor. As the function cannot judge if it is safe to change lanes, over reliance could lead to an accident resulting in death or serious injury.

As the system may not function correctly under certain conditions, the driver’s own visual confirmation of safety is necessary.

System components

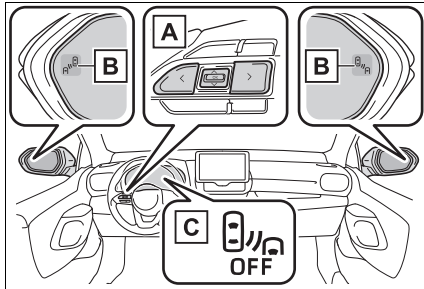

A Meter control switches

Turning the Blind Spot Monitor on/off.

B Outside rear view mirror indicators

When a vehicle is detected in a blind spot of the outside rear view mirrors or approaching rapidly from behind into a blind spot, the outside rear view mirror indicator on the detected side will illuminate. If the turn signal lever is operated toward the detected side, the outside rear view mirror indicator flashes.

C BSM OFF indicator

Illuminates when the Blind Spot Monitor is disabled.

■ Outside rear view mirror indicator visibility

In strong sunlight, the outside rear view mirror indicator may be difficult to see.

■ When “Blind Spot Monitor Unavailable See Owner’s Manual” is shown on the multi-information display

Ice, snow, mud, etc., may be attached to the rear bumper around the sensors. (→P.249) The system should return to normal operation after removing the ice, snow, mud, etc., from the rear bumper. Additionally, the sensors may not operate normally when driving in extremely

hot or cold environments.

■ When “Blind Spot Monitor Malfunction Visit Your Dealer” is shown on the multi-information display

There may be a sensor malfunction or misaligned. Have the vehicle inspected by any authorized Toyota retailer or Toyota authorized repairer, or any reliable repairer.

■ Customization

Some functions can be customized. (→P.431)

■ Certifications for the Blind Spot Monitor

→P.542

⚠ WARNING

■ To ensure the system can operate properly

Blind Spot Monitor sensors are installed behind the left and right sides of the rear bumper respectively. Observe the following to ensure the Blind Spot Monitor can operate correctly.

⚠ WARNING

- Keep the sensors and the surrounding areas on the rear bumper clean at all times.

If a sensor or its surrounding area on the rear bumper is dirty or covered with snow, the Blind Spot Monitor may not operate and a warning message (→P.249) will be displayed. In this situation, clear off the dirt or snow and drive the vehicle with the operation conditions of the BSM function (→P.252) satisfied for approximately 10 minutes. If the warning message does not disappear, have the vehicle inspected by any authorized Toyota retailer or Toyota authorized repairer, or any reliable repairer.

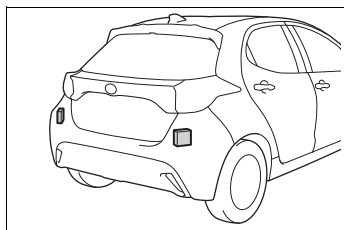



- Do not attach accessories, stickers (including transparent stickers), aluminum tape, etc., to a sensor or its surrounding area on the rear bumper.
- Do not subject a sensor or its surrounding area on the rear bumper to a strong impact. If a sensor is moved even slightly off position, the system may malfunction and vehicles may not be detected correctly. In the following situations, have your vehicle inspected by any authorized Toyota retailer or Toyota authorized repairer, or any reliable repairer.
 - A sensor or its surrounding area is subject to a strong impact.

- If the surrounding area of a sensor is scratched or dented, or part of them has become disconnected.
- Do not disassemble the sensor.
- Do not modify the sensor or surrounding area on the rear bumper.
- If a sensor or the rear bumper needs to be removed/installed or replaced, contact any authorized Toyota retailer or Toyota authorized repairer, or any reliable repairer.
- Do not paint the rear bumper any color other than an official Toyota color.

Turning the Blind Spot Monitor on/off

Use the meter control switches to turn on/off the function.

- 1 Press < / > (vertical display) or ^ / v (horizontal display) of the meter control switch to select .
- 2 Press ^ / v (vertical display) or < / > (horizontal display) of the meter control switch to select  and then press OK.

Blind Spot Monitor operation

■ Vehicles that can be detected by the Blind Spot Monitor

The Blind Spot Monitor uses rear side radar sensors to detect the following vehicles traveling in adjacent lanes and advises the driver of the presence of such vehicles via the indicators on the outside rear view mirrors.

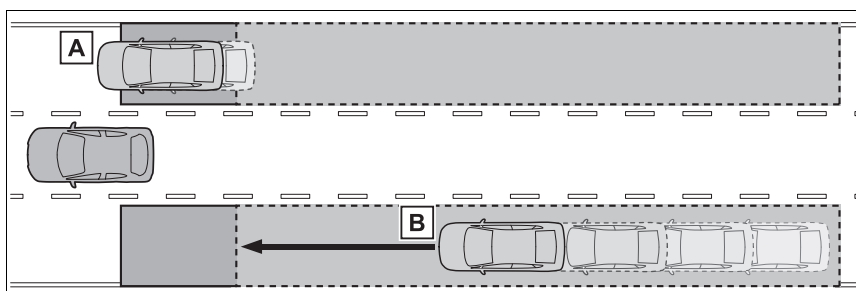

- A** Vehicles that are traveling in areas that are not visible using the outside rear view mirrors (the blind spots)
- B** Vehicles that are approaching rapidly from behind in areas that are not visible using the outside rear view mirrors (the blind spots)

■ The Blind Spot Monitor detection areas

The areas that vehicles can be detected in are outlined below.

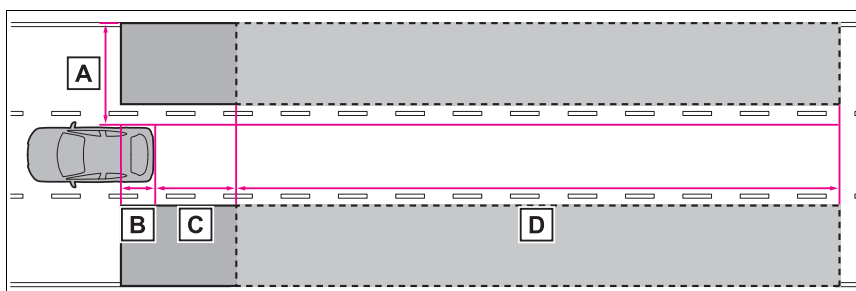

The range of each detection area is:

- A** Approximately 0.5 m (1.6 ft.) to 3.5 m (11.5 ft.) from either side of the vehicle^{*1}
- B** Approximately 1 m (3.3 ft.) forward of the rear bumper
- C** Approximately 3 m (9.8 ft.) from the rear bumper

D Approximately 3 m (9.8 ft.) to 60 m (197 ft.) from the rear bumper*²

*¹: The area between the side of the vehicle and 0.5 m (1.6 ft.) from the side of the vehicle cannot be detected.

*²: The greater the difference in speed between your vehicle and the detected vehicle is, the farther away the vehicle will be detected, causing the outside rear view mirror indicator to illuminate or flash.

■ The Blind Spot Monitor is operational when

The Blind Spot Monitor is operational when all of the following conditions are met:

- The Blind Spot Monitor is on.
- The shift lever is in a position other than R.
- The vehicle speed is greater than approximately 16 km/h (10 mph).

■ The Blind Spot Monitor will detect a vehicle when

The Blind Spot Monitor will detect a vehicle present in the detection area in the following situations:

- A vehicle in an adjacent lane overtakes your vehicle.
- You overtake a vehicle in adjacent lane slowly.
- Another vehicle enters the detection area when it changes lanes.

■ Conditions under which the system will not detect a vehicle

The Blind Spot Monitor is not designed to detect the following types of vehicles and/or objects:

- Small motorcycles, bicycles, pedestrians, etc.*
- Vehicles traveling in the opposite direction
- Guardrails, walls, signs, parked vehicles and similar stationary objects*
- Following vehicles that are in the same lane*
- Vehicles traveling 2 lanes away from

your vehicle*

- Vehicles which are being overtaken rapidly by your vehicle*

*: Depending on the conditions, detection of a vehicle and/or object may occur.

■ Conditions under which the system may not function correctly

- The Blind Spot Monitor may not detect vehicles correctly in the following situations:
 - When the sensor is misaligned due to a strong impact to the sensor or its surrounding area
 - When mud, snow, ice, a sticker, etc., is covering the sensor or surrounding area on the rear bumper
 - When driving on a road surface that is wet with standing water during bad weather, such as heavy rain, snow, or fog
 - When multiple vehicles are approaching with only a small gap between each vehicle
 - When the distance between your vehicle and a following vehicle is short
 - When there is a significant difference in speed between your vehicle and the vehicle that enters the detection area
 - When the difference in speed between your vehicle and another vehicle is changing
 - When a vehicle enters a detection area traveling at about the same speed as your vehicle
 - As your vehicle starts from a stop, a vehicle remains in the detection area
 - When driving up and down consecutive steep inclines, such as hills, dips in the road, etc.

- When driving on roads with sharp bends, consecutive curves, or uneven surfaces
- When vehicle lanes are wide, or when driving on the edge of a lane, and the vehicle in an adjacent lane is far away from your vehicle
- When towing a trailer
- When an accessory (such as a bicycle carrier) is installed to the rear of the vehicle
- When there is a significant difference in height between your vehicle and the vehicle that enters the detection area
- Immediately after the Blind Spot Monitor is turned on
- Instances of the Blind Spot Monitor unnecessarily detecting a vehicle and/or object may increase in the following situations:
 - When the sensor is misaligned due to a strong impact to the sensor or its surrounding area
 - When the distance between your vehicle and a guardrail, wall, etc., that enters the detection area is short
 - When driving up and down consecutive steep inclines, such as hills, dips in the road, etc.
 - When vehicle lanes are narrow, or when driving on the edge of a lane, and a vehicle traveling in a lane other than the adjacent lanes enters the detection area
 - When driving on roads with sharp bends, consecutive curves, or uneven surfaces
 - When the tires are slipping or spinning
 - When the distance between your vehicle and a following vehicle is short
 - When an accessory (such as a bicycle carrier) is installed to the rear of the vehicle

Toyota parking assist-sensor*

*: If equipped

The distance from your vehicle to objects, such as a wall, when parallel parking or maneuvering into a garage is measured by the sensors and communicated via the multi-information display and a buzzer. Always check the surrounding area when using this system.

System components

■ Location and types of sensors

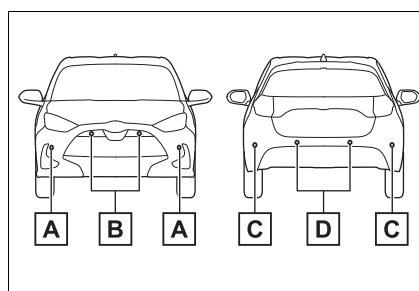

A Front corner sensors

B Front center sensors

C Rear corner sensors

D Rear center sensors

■ Display

When the sensors detect an object, such as a wall, a graphic is shown on the multi-information display depending on the position and dis-

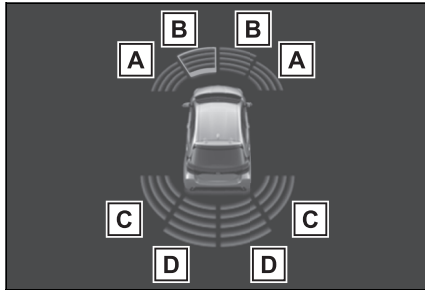

tance to the object. (As the distance to the object becomes short, the distance segments may blink.)



- A** Front corner sensor detection
- B** Front center sensor detection
- C** Rear corner sensor detection
- D** Rear center sensor detection



Turning Toyota parking assist-sensor on/off

Use the meter control switches to enable/disable the Toyota parking assist-sensor. (→P.104, 110)

- 1 Press **< / >** (vertical display) or **^ / v** (horizontal display) of the meter control switch to select .
- 2 Press **^ / v** (vertical display) or **< / >** (horizontal display) of the meter control switch to select  and then press OK.

When the Toyota parking assist-sensor function is disabled, the

Toyota parking assist-sensor OFF indicator (→P.92) illuminates.

To re-enable the system when it was disabled, select  on the multi-information display, select  and then on. If disabled using this method, the system will not be re-enabled by turning the power switch off and then to ON.

WARNING

■ Cautions regarding the use of the system

There is a limit to the degree of recognition accuracy and control performance that this system can provide, do not overly rely on this system. The driver is always responsible for paying attention to the vehicle's surroundings and driving safely.

■ To ensure the system can operate properly

Observe the following precautions. Failing to do so may result in the vehicle being unable to be driven safely and possibly cause an accident.

- Do not damage the sensors, and always keep them clean.
- Do not a sticker or an electronic component, such as a backlit license plate (especially fluorescent type), fog lights, fender pole or wireless antenna is installed near a radar sensor.

⚠ WARNING

- Do not subject the radar sensor or its surrounding area to a strong impact. If the radar sensor, front grille, or front bumper has been subjected to a strong impact, have the vehicle inspected by any authorized Toyota retailer or Toyota authorized repairer, or any reliable repairer. If a sensor or the rear bumper needs to be removed/installed or replaced, contact any authorized Toyota retailer or Toyota authorized repairer, or any reliable repairer.

- Do not modify, disassemble or paint the sensors.

- Do not attach a license plate cover.

- Keep your tires properly inflated.

■ When to disable the function

In the following situations, disable the function as it may operate even though there is no possibility of a collision.

- Failing to observe the warnings above.

- A non-genuine Toyota suspension (lowered suspension, etc.) is installed.

■ Notes when washing the vehicle

Do not apply intensive bursts of water or steam to the sensor area.

Doing so may result in the sensor malfunctioning.

- When using a high pressure washer to wash the vehicle, do not spray the sensors directly, as doing so may cause a sensor to malfunction.

- When using steam to clean the vehicle, do not direct steam too close to the sensors as doing so may cause a sensor to malfunction.

■ The system can be operated when

- The power switch is in ON.

- Toyota parking assist-sensor function is on.

- The vehicle speed is less than about 10 km/h (6 mph).

- The shift lever is in other than P.

■ If “Clean Parking Assist Sensor” is displayed on the multi-information display

A sensor may be covered with water drops, ice, snow, dirt, etc. Remove the water drops, ice, snow, dirt, etc., from the sensor to return the system to normal.

Also, due to ice forming on a sensor at low temperatures, a warning message may be displayed or the sensor may not be able to detect an object. Once the ice melts, the system will return to normal.

If a warning message is displayed even if the sensor is clean, there may be a sensor malfunction. Have the vehicle inspected by any authorized Toyota retailer or Toyota authorized repairer, or any reliable repairer.

**■ Sensor detection information**

- The sensor's detection areas are limited to the areas around the vehicle' front and rear bumpers.

- The following situations may occur during use.

- Depending on the shape of the object and other factors, the detection distance may shorten, or detection may be impossible.
- Detection may be impossible if static objects draw too close to the sensor.
- There will be a short delay between

static object detection and display (warning buzzer sounds). Even at low speeds, there is a possibility that the object will come within 30 cm (1.0 ft.) before the display is shown and the warning buzzer sounds.

- It might be difficult to hear the buzzer due to the volume of the audio system or air flow noise of the air conditioning system.
- It may be difficult to hear the sound of this system due to the buzzers of other systems.

■ **Objects which the system may not be properly detected**

The shape of the object may prevent the sensor from detecting it. Pay particular attention to the following objects:

- Wires, fences, ropes, etc.
- Cotton, snow and other materials that absorb sound waves
- Sharply-angled objects
- Low objects
- Tall objects with upper sections projecting outwards in the direction of your vehicle

■ **Situations in which the system may not operate properly**

Certain vehicle conditions and the surrounding environment may affect the ability of a sensor to correctly detect objects. Particular instances where this may occur are listed below.

- There is dirt, snow, water drops or ice on a sensor. (Cleaning the sensors will resolve this problem.)
- A sensor is frozen. (Thawing the area will resolve this problem.)
In especially cold weather, if a sensor is frozen the sensor display may be displayed abnormally, or objects, such as a wall, may not be detected.
- When a sensor or the area around a sensor is extremely hot or cold.

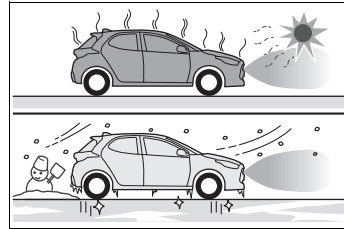

- On an extremely bumpy road, on an incline, on gravel, or on grass.
- When vehicle horns, vehicle detectors, motorcycle engines, air brakes of large vehicles, the clearance sonar of other vehicles or other devices which produce ultrasonic waves are near the vehicle
- A sensor is coated with a sheet of spray or heavy rain.
- If objects draw too close to the sensor.
- Pedestrians that are hard to reflect ultrasonic waves (ex. skirts with gathers or frills).
- When objects that are not perpendicular to the ground, not perpendicular to the vehicle traveling direction, uneven, or waving are in the detection range.
- Strong wind is blowing
- When driving in inclement weather such as fog, snow or a sandstorm
- When an object that cannot be detected is between the vehicle and a detected object
- If an object such as a vehicle, motorcycle, bicycle or pedestrian cuts in front of the vehicle or runs out from the side of the vehicle
- If the orientation of a sensor has been changed due to a collision or other impact
- When equipment that may obstruct a sensor is installed, such as a towing eyelet, bumper protector (an additional trim strip, etc.), bicycle carrier, or snow plow
- If the front of the vehicle is raised or lowered due to the carried load

- If the vehicle cannot be driven in a stable manner, such as when the vehicle has been in an accident or is malfunctioning
- When a tire chains, compact spare tire or an emergency tire puncture repair kit is used

■ **Situations in which the system may operate even if there is no possibility of a collision**

In some situations, such as the following, the system may operate even though there is no possibility of a collision.

- When driving on a narrow road

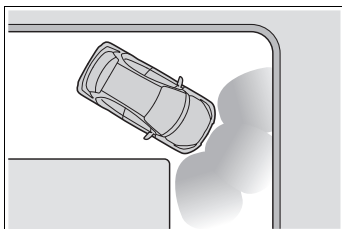

- When driving toward a banner, flag, low-hanging branch or boom barrier (such as those used at railroad crossings, toll gates and parking lots)
- When there is a rut or hole in the surface of the road
- When driving on a metal cover (grating), such as those used for drainage ditches
- When driving up or down a steep slope
- If a sensor is hit by a large amount of water, such as when driving on a flooded road
- There is dirt, snow, water drops or ice on a sensor. (Cleaning the sensors will resolve this problem.)
- A sensor is coated with a sheet of spray or heavy rain
- When driving in inclement weather such as fog, snow or a sandstorm
- When strong winds are blowing

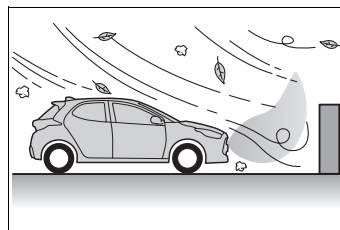

- When vehicle horns, vehicle detectors, motorcycle engines, air brakes of large vehicles, the clearance sonar of other vehicles or other devices which produce ultrasonic waves are near the vehicle
- If the front of the vehicle is raised or lowered due to the carried load
- If the orientation of a sensor has been changed due to a collision or other impact
- The vehicle is approaching a tall or curved curb
- Driving close to columns (H-shaped steel beams, etc.) in multi-story parking garages, construction sites, etc.
- If the vehicle cannot be driven in a stable manner, such as when the vehicle has been in an accident or is malfunctioning
- On an extremely bumpy road, on an incline, on gravel, or on grass

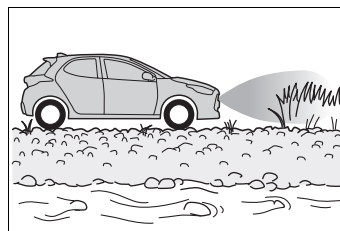

- When a tire chains, compact spare tire or an emergency tire puncture repair kit is used

Sensor detection display, object distance

■ **Detection range of the sensors**

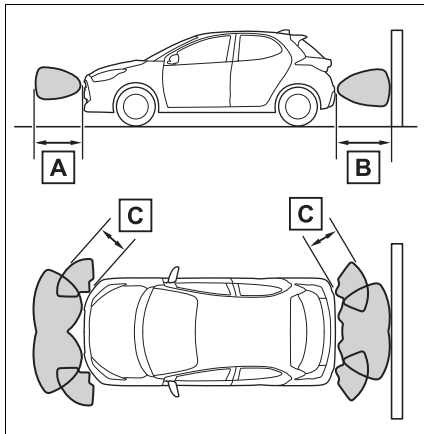

- A** Approximately 100 cm (3.3 ft.)
- B** Approximately 150 cm (4.9 ft.)
- C** Approximately 60 cm (2.0 ft.)

The diagram shows the detection range of the sensors. Note that the sensors cannot detect objects that are extremely close to the vehicle.

The range of the sensors may change depending on the shape of the object, etc.

■ **The distance and buzzer**

Approximate distance to obstacle	Buzzer
Front sensor: 100 cm to 60 cm (3.3 ft. to 2.0 ft.)*	Slow
Rear sensor: 150 cm to 60 cm (4.9 ft. to 2.0 ft.)*	
60 cm to 45 cm (2.0 ft. to 1.5 ft.)*	Medium
45 cm to 30 cm (1.5 ft. to 1.0 ft.)*	Fast
30 cm to 15 cm (1.0 ft. to 0.5 ft.)	Continuous
Less than 15 cm (0.5 ft.)	

*: Automatic buzzer mute function is enabled. (→P.258)

■ **Buzzer operation and distance to an object**

A buzzer sounds when the sensors are operating.

- The buzzer beeps faster as the vehicle approaches an object. When the vehicle comes within

approximately 30 cm (1.0 ft.) of the object, the buzzer sounds continuously.





- When 2 or more sensors simultaneously detect a static object, the buzzer sounds for the nearest object.





- Even when the sensors are operating, the buzzer will be muted in some situations. (automatic buzzer mute function)

■ Adjusting the buzzer volume

The buzzer volume can be adjusted on the multi-information display.

Use the meter control switches to change settings. (→P.104, 110)

- 1 Press  /  (vertical display) or  /  (horizontal display) of the meter control switch to select .

- 2 Press  /  (vertical display) or  /  (horizontal display) of the meter control switch to select  and then press and hold OK.

- 3 Select the volume and then press OK.

Each time the switch is pressed, the volume level will change between 1, 2, and 3.

■ Muting a buzzer

A mute button will be displayed on the multi-information display when an object is detected. To mute the buzzer, press OK.

The buzzers for the Toyota parking assist-sensor and RCTA function (if equipped) will be muted simultane-

ously.

Mute will be canceled automatically in the following situations:

- When the shift lever is changed.
- When the vehicle speed exceeds a certain speed.
- When there is a malfunction in a sensor or the system is temporarily unavailable.
- When the operating function is disabled manually.
- When the power switch is turned off.

RCTA (Rear Crossing Traffic Alert)*

*: If equipped

The RCTA function uses the BSM radar sensors installed on the inner side of the position above the rear bumper. This function is intended to assist the driver in checking areas that are not easily visible when backing up.

⚠ WARNING

■ Cautions regarding the use of the system

There is a limit to the degree of recognition accuracy and control performance that this system can provide, do not overly rely on this system. The driver is always responsible for paying attention to the vehicle's surroundings and driving safely. (→P.248)

■ To ensure the system can operate properly

→P.249

System components

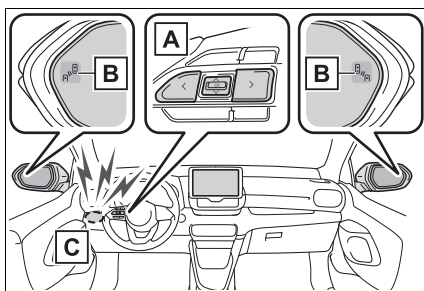

A Meter control switches

Turn the RCTA function on/off.

B Outside rear view mirror indicators

When a vehicle approaching from the right or left at the rear of the vehicle is detected, both outside rear view mirror indicators will flash.

C RCTA buzzer

If a vehicle approaching from the right or left at the rear of the vehicle is detected, a buzzer will sound.

Turning the RCTA function on/off

Use the meter control switches to turn on/off the function. (→P.104, 110)

- 1 Press < / > (vertical display) or ^ / v (horizontal display) of the meter control switch to select .
- 2 Press ^ / v (vertical display) or < / > (horizontal display) of the meter control switch to select "RCTA" and then press OK.

When the RCTA function is disabled, the "RCTA OFF" indicator (→P.92) illuminates. (Each time the power switch is turned off then changed to ON, the RCTA function will be enabled automatically.)

■ Outside rear view mirror indicator visibility

When under strong sunlight, the outside

rear view mirror indicator may be difficult to see.

■ **Hearing the RCTA buzzer**

The RCTA buzzer may be difficult to hear over loud noises, such as high audio system volume.

■ **When “Rear Cross Traffic Alert Unavailable See Owner’s Manual” is shown on the multi-information display**

The sensor voltage has become abnormal, or water, snow, mud, etc., may be built up in the vicinity of the sensor area of the position above the rear bumper. (→P.249) Removing the water, snow, mud, etc., from the vicinity of the sensor area should return it to normal. Also, the sensor may not function normally when used in extremely hot or cold weather.

■ **When “Rear Cross Traffic Alert Malfunction Visit Your Dealer” is shown on the multi-information display**

There may be a sensor malfunction or misaligned. Have the vehicle inspected by any authorized Toyota retailer or Toyota authorized repairer, or any reliable repairer.

■ **Radar sensors**

→P.249

RCTA function

■ **Operation of the RCTA function**

The RCTA function uses radar sensors to detect vehicles approaching from the right or left at the rear of the vehicle and alerts the driver of the presence of such vehicles by flashing the outside rear view mirror indicators and sounding a buzzer.

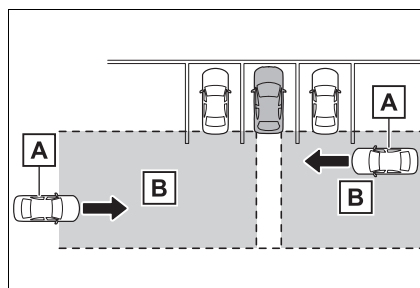

- A** Approaching vehicles
- B** Detection areas of approaching vehicles

■ **RCTA function detection areas**

The areas that vehicles can be detected in are outlined below.

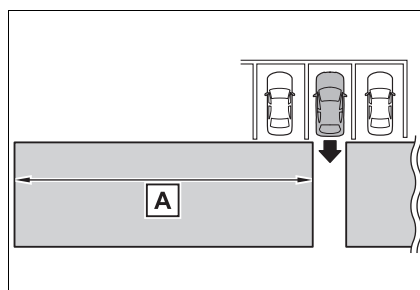

The buzzer can alert for faster vehicles approaching from farther away.

Example:

Approaching vehicle	Speed	A Approximate alert distance
Fast	28 km/h (17 mph)	20 m (66 ft.)
Slow	8 km/h (5 mph)	5.5 m (18 ft.)

■ **The RCTA function is operational when**

The RCTA function operates when all of the following conditions are met:

- The RCTA function is on.
- The shift lever is in R.
- The vehicle speed is less than approximately 8 km/h (5 mph).
- The approaching vehicle speed is between approximately 8 km/h (5 mph) and 28 km/h (17 mph).

■ **Adjusting the buzzer volume**

The buzzer volume can be adjusted on the multi-information display.

Use the meter control switches to change settings. (→P.104, 110)

- 1 Press < / > (vertical display) or ^ / v (horizontal display) of the meter control switch to select .
- 2 Press ^ / v (vertical display) or < / > (horizontal display) of the meter control switch to select "RCTA" and then press and hold OK.

- 3 Press OK to select the volume.

Each time the switch is pressed, the volume level will change between 1, 2, and 3.

When the buzzer volume adjustment is completed, press ↵ to return to the previous screen.

■ **Muting a buzzer temporarily**

A mute button will be displayed on the multi-information display when a vehicle or an object is detected. To mute the buzzer, press OK.

The buzzers for the RCTA function and

Toyota parking assist-sensor will be muted simultaneously.

Mute will be canceled automatically in the following situations:

- When the shift lever is changed.
- When the vehicle speed exceeds a certain speed.
- When there is a malfunction in a sensor or the system is temporarily unavailable.
- When the operating function is disabled manually.
- When the power switch is turned off.

■ **Conditions under which the system will not detect a vehicle**

The RCTA function is not designed to detect the following types of vehicles and/or objects.

- Vehicles approaching from directly behind
- Vehicles backing up in a parking space next to your vehicle
- Vehicles that the sensors cannot detect due to obstructions

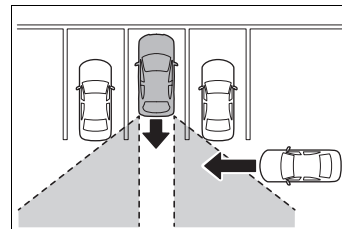

- Guardrails, walls, signs, parked vehicles and similar stationary objects*
- Small motorcycles, bicycles, pedestrians, etc.*
- Vehicles moving away from your vehicle
- Vehicles approaching from the parking spaces next to your vehicle*
- The distance between the sensor and approaching vehicle gets too close

*: Depending on conditions, detection of a vehicle and/or object may occur.

■ Situations in which the system may not operate properly

The RCTA function may not detect vehicles correctly in the following situations:

- When the sensor is misaligned due to a strong impact to the sensor or its surrounding area
- When mud, snow, ice, a sticker, etc., is covering the sensor or surrounding area on the position above the rear bumper
- When driving on a road surface that is wet with standing water during bad weather, such as heavy rain, snow, or fog
- When multiple vehicles are approaching with only a small gap between each vehicle
- When a vehicle is approaching at high speed
- When equipment that may obstruct a sensor is installed, such as a towing eyelet, bumper protector (an additional trim strip, etc.), bicycle carrier, or snow plow
- When backing up on a slope with a sharp change in grade

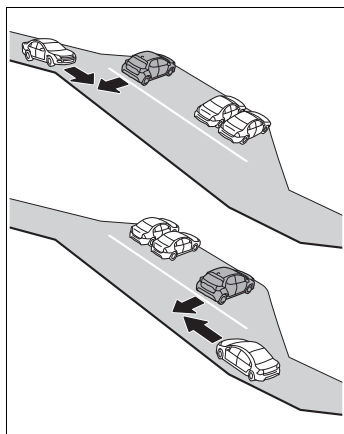

- When backing out of a sharp angle parking spot

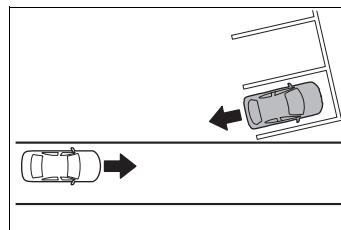

- When towing a trailer
- When there is a significant difference in height between your vehicle and the vehicle that enters the detection area
- When a sensor or the area around a sensor is extremely hot or cold
- If the suspension has been modified or tires of a size other than specified are installed
- If the front of the vehicle is raised or lowered due to the carried load
- When turning while backing up

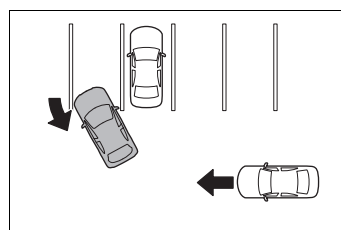

- When a vehicle turns into the detection area

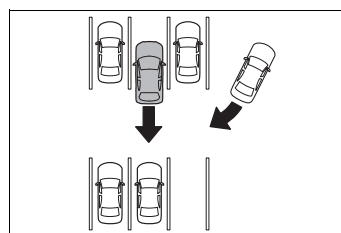

■ Situations in which the system may operate even if there is no possibility of a collision

Instances of the RCTA function unnecessarily detecting a vehicle and/or object may increase in the following situations:

- When the parking space faces a street and vehicles are being driven on the street

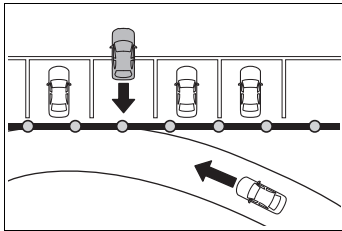

- When the distance between your vehicle and metal objects, such as a guardrail, wall, sign, or parked vehicle, which may reflect electrical waves toward the rear of the vehicle, is short

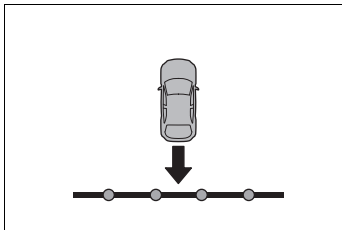

- When equipment that may obstruct a sensor is installed, such as a towing eyelet, bumper protector (an additional trim strip, etc.), bicycle carrier, or snow plow
- When a vehicle passes by the side of your vehicle

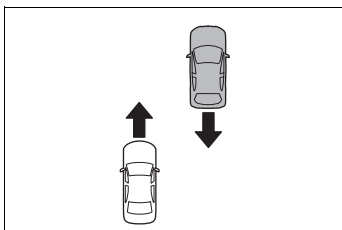

- When a detected vehicle turns while approaching the vehicle

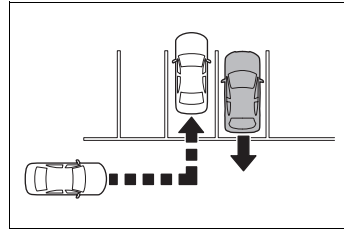

- When there are spinning objects near your vehicle such as the fan of an air conditioning unit
- When water is splashed or sprayed toward the rear bumper, such as from a sprinkler
- Moving objects (flags, exhaust fumes, large rain droplets or snowflakes, rain water on the road surface, etc.)
- When the distance between your vehicle and a guardrail, wall, etc., that enters the detection area is short
- Gratings and gutters
- When a sensor or the area around a sensor is extremely hot or cold
- If the suspension has been modified or tires of a size other than specified are installed
- If the front of the vehicle is raised or lowered due to the carried load

PKSB (Parking Support Brake)*

*: If equipped

The Parking Support Brake system consists of the following functions that operate when driving at a low speed or backing up, such as when parking. When the system determines that the possibility of a collision with a detected object is high, a warning operates to urge the driver to take evasive action. If the system determines that the possibility of a collision with a detected object is extremely high, the brakes are automatically applied to help avoid the collision or help reduce the impact of the collision.

PKSB (Parking Support Brake) system

■ Parking Support Brake function (static objects)

→P.270

■ Parking Support Brake function (rear-crossing vehicles)

→P.273

WARNING

■ Cautions regarding the use of the system

Do not overly rely on the system, as doing so may lead to an accident.

Always drive while checking the safety of the surroundings of the vehicle.

Depending on the vehicle and road conditions, weather, etc., the system may not operate.

The detection capabilities of sensors and radars are limited. Always drive while checking the safety of the surroundings of the vehicle.

- The driver is solely responsible for safe driving. Always drive carefully, taking care to observe your surroundings. The Parking Support Brake system is designed to provide support to lessen the severity of collisions. However, it may not operate in some situations.
- The Parking Support Brake system is not designed to stop the vehicle completely. Additionally, even if the system has stopped the vehicle, it is necessary to depress the brake pedal immediately as brake control will be canceled after approximately 2 seconds.
- It is extremely dangerous to check the system operations by intentionally driving the vehicle into the direction of a wall, etc. Never attempt such actions.

■ When to disable the Parking Support Brake

In the following situations, disable the Parking Support Brake as the system may operate even though there is no possibility of a collision.

- When inspecting the vehicle using a chassis roller, chassis dynamo or free roller

 **WARNING**

- When loading the vehicle onto a boat, truck or other transport vessel
- If the suspension has been modified or tires of a size other than specified are installed
- If the front of the vehicle is raised or lowered due to the carried load
- When equipment that may obstruct a sensor is installed, such as a towing eyelet, bumper protector (an additional trim strip, etc.), bicycle carrier, or snow plow
- When using automatic car washing devices
- If the vehicle cannot be driven in a stable manner, such as when the vehicle has been in an accident or is malfunctioning
- When the vehicle is driven in a sporty manner or off-road
- When the tires are not properly inflated
- When the tires are very worn
- When a tire chains, compact spare tire or an emergency tire puncture repair kit is used

 **NOTICE**









■ **If “PKSB Unavailable” is displayed on the multi-information display and the PKSB OFF indicator is on**

If this message is displayed immediately after the power switch is changed to ON, operate the vehicle carefully, paying attention to your surroundings. It may be necessary to drive the vehicle for a certain amount of time before the system returns to normal. (If the system is not return to normal after driving for a while, clean the sensors and their surrounding area on the bumpers.)



Enabling/Disabling the Parking Support Brake

The Parking Support Brake can be enabled/disabled on the multi-information display. All of the Parking Support Brake functions (static objects and rear-crossing vehicles) are enabled/disabled simultaneously.

Use the meter control switches to enable/disable the parking support brake. (→P.104, 110)

- 1 Press  /  (vertical display) or  /  (horizontal display) of the meter control switch to select .
- 2 Press  /  (vertical display) or  /  (horizontal display) of the meter control switch to select  and then press OK.

When the Parking Support Brake is disabled, the PKSB OFF indicator (→P.92) illuminates.

To re-enable the system when it was disabled, select  on the multi-information display, select  and then On. If disabled using this method, the system will not be re-enabled by turning the power switch off and then to ON.

Display and buzzer for hybrid system output restriction control and brake control

If the hybrid system output restriction control or brake control operates, a buzzer will sound and a message will be displayed on the multi-information display and head-up display (if equipped) to alert the driver.

Depending on the situation, hybrid system output restriction control will operate to either limit acceleration or restrict output as much as possible.

- Hybrid system output restriction control is operating (acceleration restriction)

Acceleration greater than a certain amount is restricted by the system.

Multi-information display: "Object Detected Acceleration Reduced"

Head-up display (if equipped): No warning displayed

PKSB OFF indicator: Not illuminated

Buzzer: Does not sound

- Hybrid system output restriction control is operating (output

restricted as much as possible)

The system has determined that stronger-than-normal brake operation is necessary.

Multi-information display and head-up display (if equipped): "BRAKE!"

PKSB OFF indicator: Not illuminated

Buzzer: Short beep

- Brake control is operating

The system determined that emergency braking is necessary.

Multi-information display and head-up display (if equipped): "BRAKE!"

PKSB OFF indicator: Not illuminated

Buzzer: Short beep

- Vehicle stopped by system operation

The vehicle has been stopped by brake control operation.

Multi-information display and head-up display (if equipped): "Switch to Brake" (If the accelerator pedal is not depressed, "Press Brake Pedal" will be displayed.)

PKSB OFF indicator: Illuminated

Buzzer: Short beep

System overview

If the Parking Support Brake determines that a collision with a detected object is possible, the hybrid system output will be restricted to restrain any increase in the vehicle speed. (Hybrid system output restriction control: See figure 2.)

Additionally, if the accelerator pedal continues to be depressed, the

brakes will be applied automatically to reduce the vehicle speed. (Brake control: See figure 3.)

- Figure 1: When the PKSB (Parking Support Brake) is not operating

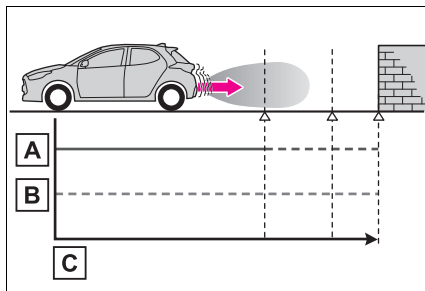

- A** Hybrid system output
- B** Braking force
- C** Time

- Figure 2: When hybrid system output restriction control operates

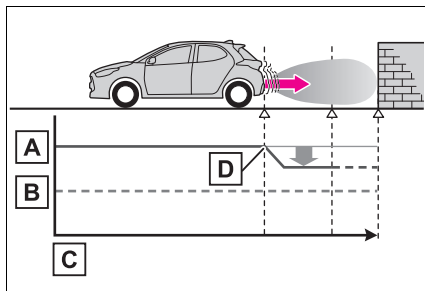

- A** Hybrid system output
- B** Braking force
- C** Time
- D** Hybrid system output restriction control begins operating (System determines that possibility of collision with detected object is high)

tem determines that possibility of collision with detected object is high)

- Figure 3: When engine output restriction control and brake control operates

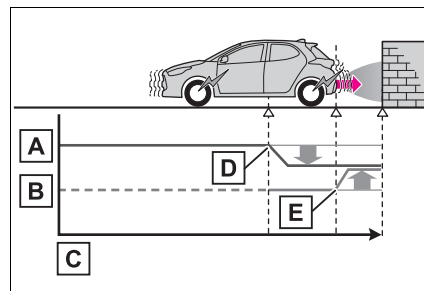

- A** Hybrid system output
- B** Braking force
- C** Time
- D** Hybrid system output restriction control begins operating (System determines that possibility of collision with detected object is high)
- E** Brake control begins operating (System determines that possibility of collision with detected object is extremely high)

■ **If the Parking Support Brake has operated**

If the vehicle is stopped due to operation of the Parking Support Brake, the Parking Support Brake will be disabled and the PKSB OFF indicator will illuminate. If the Parking Support Brake operates unnecessarily, brake control can be canceled by depressing the brake pedal or waiting for approximately 2 seconds for

it to automatically be canceled. Then, the vehicle can be operated by depressing the accelerator pedal.

■ **Re-enabling the Parking Support Brake**

To re-enable the Parking Support Brake when it is disabled due to operation of the Parking Support Brake, either enable the system again (→P.266), or turn the power switch off and then back to ON. Additionally, if the object becomes no longer in the traveling direction of the vehicle or if the traveling direction of the vehicle changes (such as changing from moving forward to backing up, or from backing up to moving forward), the system will be re-enabled automatically.

■ **If “PKSB Unavailable” is displayed on the multi-information display and the PKSB OFF indicator is on**

If the vehicle is stopped due to operation of the Parking Support Brake, the Parking Support Brake will be disabled and the PKSB OFF indicator will illuminate.

- A sensor may be covered with water drops, ice, snow, dirt, etc. Remove the water drops, ice, snow, dirt, etc., from the sensor to return the system to normal.
Also, due to ice forming on a sensor at low temperatures, a warning message may be displayed or the sensor may not be able to detect an object. Once the ice melts, the system will return to normal.
- If this message is displayed, a sensor on the front or rear bumper may be dirty. Clean the sensors and their surrounding area on the bumpers.
- If this message continues to be displayed even after cleaning the sensor, or is displayed even though the sensor is clean, have the vehicle inspected by any authorized Toyota retailer or Toyota authorized repairer, or any reliable repairer.

■ **If a 12-volt battery terminal has been disconnected and reconnected**

The system needs to be initialized. To initialize the system, drive the vehicle straight ahead for 5 seconds or more at a speed of approximately 35 km/h (22 mph) or more.

Parking Support Brake function (static objects)*

*: If equipped

If the sensors detect a static object, such as a wall, in the traveling direction of the vehicle and the system determines that a collision may occur due to the vehicle suddenly moving forward due to an accidental accelerator pedal operation, the vehicle moving the unintended direction due to the wrong shift position being selected, or while parking or traveling at low speeds, the system will operate to lessen the impact with the detected static object and reduce the resulting damage.

Examples of function operation

This function will operate in situations such as the following if an object is detected in the traveling direction of the vehicle.

- When traveling at a low speed and the brake pedal is not depressed, or is depressed late

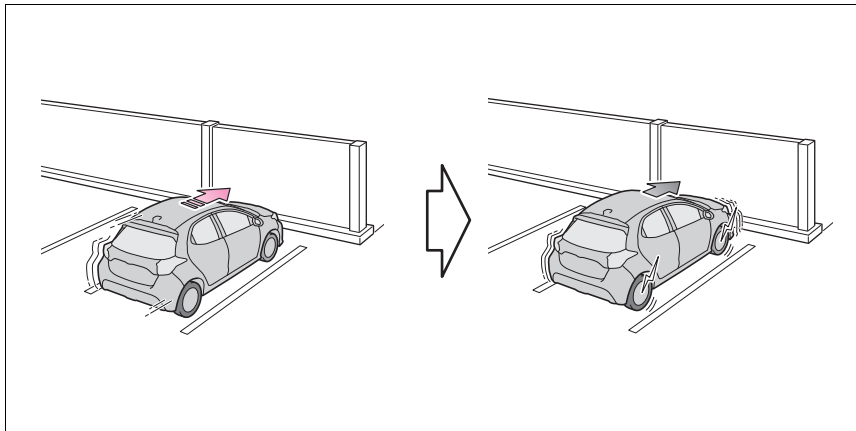

■ When the accelerator pedal is depressed excessively

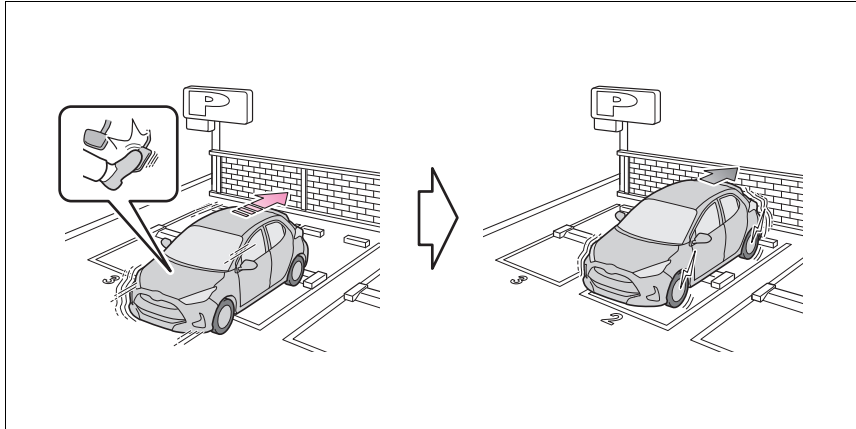

■ When the vehicle moves in the unintended direction due to the wrong shift position being selected

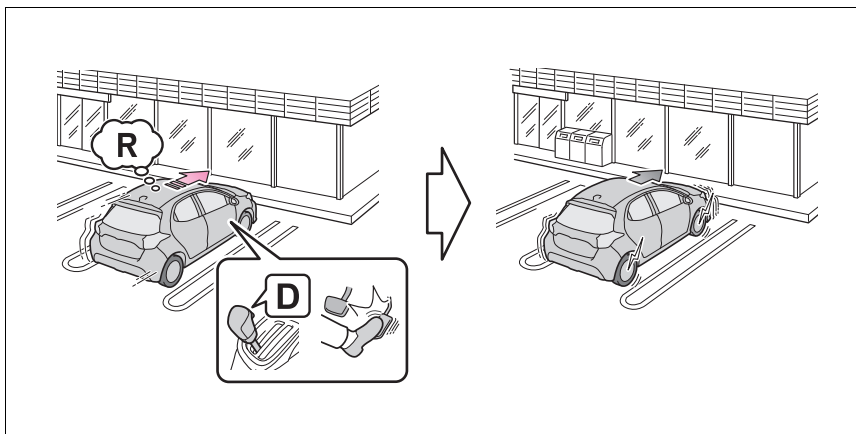

Types of sensors

→P.253

⚠ WARNING

■ To ensure the system can operate properly

→P.254

■ If the Parking Support Brake function (static objects) operates unnecessarily, such as at a railroad crossing

→P.268

■ Notes when washing the vehicle

→P.255

■ The Parking Support Brake function (static object) will operate when

The function will operate when the PKSB OFF indicator is not illuminated or flashing (→P.91, 92) and all of the following conditions are met:

- Hybrid system output restriction control
- The Parking Support Brake is enabled.
- The vehicle speed is approximately 15 km/h (9 mph) or less.
- There is a static object in the traveling direction of the vehicle and approximately 2 to 4 m (6 to 13 ft.) away.
- The Parking Support Brake determines that a stronger-than-normal brake operation is necessary to avoid a collision.
- Brake control
- Hybrid system output restriction control is operating.
- The Parking Support Brake determines that an immediate brake operation is necessary to avoid a collision.

■ The Parking Support Brake function (static objects) will stop operating when

The function will stop operating if any of the following conditions are met:

- Hybrid system output restriction control
- The Parking Support Brake is disabled.
- The system determines that the collision has become avoidable with normal brake operation.
- The static object is no longer approximately 2 to 4 m (6 to 13 ft.) away from the vehicle or in the traveling direction of the vehicle.
- Brake control
- The Parking Support Brake is disabled.
- Approximately 2 seconds have elapsed since the vehicle was stopped by brake control.
- The brake pedal is depressed after

the vehicle is stopped by brake control.

- The static object is no longer approximately 2 to 4 m (6 to 13 ft.) away from the vehicle or in the traveling direction of the vehicle.

■ Re-enabling the Parking Support Brake function (static objects)

→P.269

■ Detection range of the Parking Support Brake function (static objects)

The detection range of the Parking Support Brake function (static objects) differs from the detection range of the Toyota parking assist-sensor. (→P.258) Therefore, even if the Toyota parking assist-sensor detects an object and provides a warning, the Parking Support Brake function (static objects) may not start operating.

■ Objects which the system may not be properly detected

→P.256

■ Toyota parking assist-sensor buzzer

Regardless of whether the Toyota parking assist-sensor buzzer is enabled or not (→P.254), if the Parking Support Brake function (static objects) is enabled (→P.266), the front or rear sensors detect an object and brake control is performed, the Toyota parking assist-sensor buzzer will sound to notify the driver of the approximate distance to the object.

■ Situations in which the system may not operate properly

→P.256

■ Situations in which the system may operate even if there is no possibility of a collision

→P.257

Parking Support Brake function (rear-crossing vehicles)*

*: If equipped

If a rear radar sensor detects a vehicle approaching from the right or left at the rear of the vehicle and the system determines that the possibility of a collision is high, this function will perform brake control to reduce the likelihood of an impact with the approaching vehicle.

Examples of function operation

This function will operate in situations such as the following if a vehicle is detected in the traveling direction of the vehicle.

- When reversing, a vehicle is approaching and the brake pedal is not depressed, or is depressed late

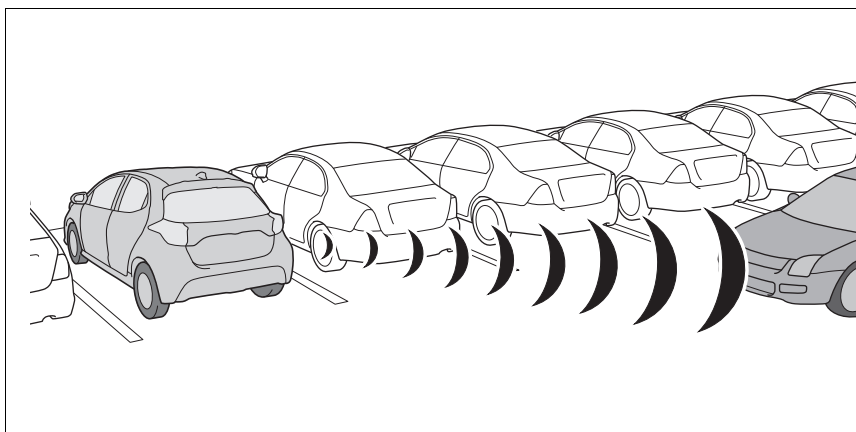

Types of sensors

→P.249

! WARNING

■ To ensure the system can operate properly

→P.260

■ The Parking Support Brake function (rear-crossing vehicles) will operate when

The function will operate when the PKSB OFF indicator is not illuminated or flashing (→P.91, 92) and all of the following conditions are met:

- Hybrid system output restriction control
- The Parking Support Brake is

- enabled.
- The vehicle speed is approximately 15 km/h (9 mph) or less.
- Vehicles are approaching from the right or left at the rear of the vehicle at a traveling speed of approximately 8 km/h (5 mph) or more.
- The shift lever is in R.
- The Parking Support Brake determines that a stronger than normal brake operation is necessary to avoid a collision with an approaching vehicle.
- Brake control
- Hybrid system output restriction control is operating.
- The Parking Support Brake determines that an emergency brake operation is necessary to avoid a collision with an approaching vehicle.

■ **The Parking Support Brake function (rear-crossing vehicles) will stop operating when**

The function will stop operating if any of the following conditions are met:

- Hybrid system output restriction control
- The Parking Support Brake is disabled.
- The collision becomes avoidable with normal brake operation.
- A vehicle is no longer approaching from the right or left at the rear of the vehicle.
- Brake control
- The Parking Support Brake is disabled.
- Approximately 2 seconds have elapsed since the vehicle was stopped by brake control.
- The brake pedal is depressed after the vehicle is stopped by brake control.
- A vehicle is no longer approaching from the right or left at the rear of the vehicle.

■ **Re-enabling the Parking Support Brake function (rear-crossing vehicles)**

→P.269

■ **Detection area of the Parking Support Brake function (rear-crossing vehicles)**

The detection area of the Parking Support Brake function (rear-crossing vehicles) differs from the detection area of the RCTA function (→P.261). Therefore, even if the RCTA function detects a vehicle and provides an alert, the Parking Support Brake function (rear-crossing vehicles) may not start operating.

■ **Conditions under which the system will not detect a vehicle**

→P.262

■ **RCTA buzzer**

Regardless of whether the RCTA function is enabled or not (→P.260), if the Parking Support Brake function is enabled (→P.266) and brake control is performed, a buzzer will sound to notify the driver.

■ **Situations in which the system may not operate properly**

→P.263

■ **Situations in which the system may operate even if there is no possibility of a collision**

→P.263

Driving mode select switch

The driving modes can be selected to suit driving condition.

Selecting a drive mode

Each time the switch is pressed, the system changes between power mode, normal mode, and ECO drive mode.

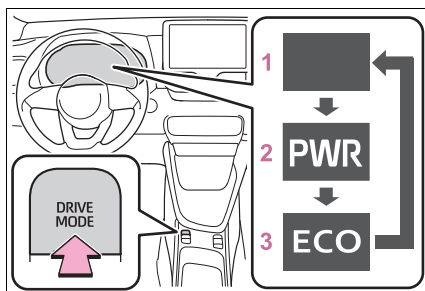

1 Normal mode

Provides an optimal balance of fuel economy, quietness, and dynamic performance. Suitable for normal driving.

2 Power mode

Controls the hybrid system to provide quick, powerful acceleration. Making it suitable for when agile driving response is desired, such as when driving on roads with many curves.

When the Power mode is selected, Power mode indicator comes on.

3 Eco drive mode

Helps the driver accelerate in an eco-friendly manner and improve fuel economy through moderate throttle characteristics and by controlling the operation of the air conditioning system (heat-

ing/cooling).

When the Eco drive mode is selected, Eco drive mode indicator comes on.

■ Operation of the air conditioning system in Eco drive mode

Eco drive mode controls the heating/cooling operations and fan speed of the air conditioning system to enhance fuel efficiency. To improve air conditioning performance, perform the following operations:

- Turn off air conditioning eco mode (→P.288)
- Adjust the fan speed (→P.289)
- Turn off Eco drive mode

■ Automatic deactivation of Power mode

If the power switch is turned off after driving in power mode, the drive mode will be changed to normal mode.

4

Driving

GPF (Gasoline Particulate Filter) system *

*: If equipped

The GPF system collects particulate matter in the exhaust gas by using an exhaust gas filter.

The system will operate to regenerate the filter automatically, depending on the vehicle conditions.

■ If “Exhaust Filter Full See Owner’s Manual” is shown on the multi-information display

- The message may be displayed while high load driving with particulate matter accumulating.
- Hybrid system (engine speed) is restricted when a certain amount of particulate matter accumulates, however, it is possible to drive the vehicle unless the malfunction indicator lamp comes on.
- Particulate matter can accumulate more quickly if the vehicle is frequently driven short trips or at low speeds, or if the hybrid system is regularly started in an extremely cold environment. Excessive accumulation of particulate matter can be prevented by periodically driving long distances continuously with intermittent releasing of the accelerator pedal, such as when driving on highways and freeways.

■ If the malfunction indicator lamp comes on or “Hybrid System Malfunction Output Power Reduced Visit Your Dealer” is shown on the multi-information display

The amount of accumulated particulate matter has exceeded a certain level. Have the vehicle inspected by any

authorized Toyota retailer or Toyota authorized repairer, or any reliable repairer immediately.

 NOTICE

■ To prevent the GPF system from not operating properly

- Do not use fuel other than the specified type
- Do not modify the exhaust pipes

Driving assist systems

To keep driving safety and performance, the following systems operate automatically in response to various driving situations. Be aware, however, that these systems are supplementary and should not be relied upon too heavily when operating the vehicle.

Summary of the driving assist systems

- **ECB (Electronically Controlled Brake System)**

The electronically controlled system generates braking force corresponding to the brake operation

- **ABS (Anti-lock Brake System)**

Helps to prevent wheel lock when the brakes are applied suddenly, or if the brakes are applied while driving on a slippery road surface

- **Brake assist**

Generates an increased level of braking force after the brake pedal is depressed when the system detects a panic stop situation

- **VSC (Vehicle Stability Control)**

Helps the driver to control skidding when swerving suddenly or turning on slippery road surfaces.

- **VSC+ (Vehicle Stability Control+)**

Provides cooperative control of the ABS, TRC, VSC and EPS.

Helps to maintain directional stability when swerving on slippery road surfaces by controlling steering performance.

- **TRC (Traction Control)**

Helps to maintain drive power and prevent the drive wheels from spinning when starting the vehicle or accelerating on slippery roads

- **Active Cornering Assist (ACA)**

Helps to prevent the vehicle from drifting to the outer side by performing inner wheel brake control when attempting to accelerate while turning

- **Hill-start assist control**

Helps to reduce the backward movement of the vehicle when starting on an uphill

- **EPS (Electric Power Steering)**

Employs an electric motor to reduce the amount of effort needed to turn the steering wheel.

- **Emergency brake signal**

When the brakes are applied suddenly, the emergency flashers automatically flash to alert the vehicle behind.

- **Secondary Collision Brake**

When the SRS airbag sensor detects a collision and the system operates, the brakes and brake

lights are automatically controlled to reduce the vehicle speed and help reduce the possibility of further damage due to a secondary collision.

■ When the TRC/VSC/ABS systems are operating

The slip indicator light will flash while the TRC/VSC/ABS systems are operating.

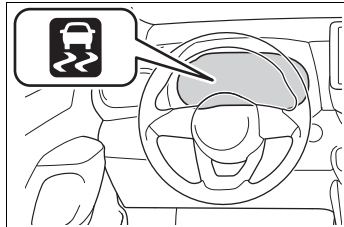

■ Disabling the TRC system

If the vehicle gets stuck in mud, dirt or snow, the TRC system may reduce power from the hybrid system to the wheels. Pressing  to turn the system off may make it easier for you to rock the vehicle in order to free it.

To turn the TRC system off, quickly press and release .

The “Traction Control Turned OFF” will be shown on the multi-information display.

Press  again to turn the system back on.

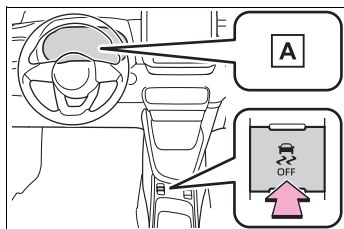

A “Traction Control Turned OFF”

■ Turning off both TRC and VSC systems

To turn the TRC and VSC systems off, press and hold  for more than 3 seconds while the vehicle is stopped. The VSC OFF indicator light will come on and the “Traction Control Turned OFF” will be shown on the multi-information display.*

Press  again to turn the system back on.

*: On vehicles with PCS (Pre-Collision System), PCS will also be disabled (only Pre-Collision warning is available). The PCS warning light will come on and a message will be displayed on the multi-information display. (→P.219)

■ When the message is displayed on the multi-information display showing that TRC has been disabled even if  has not been pressed

TRC is temporary deactivated. If the information continues to show, contact any authorized Toyota retailer or Toyota authorized repairer, or any reliable repairer.

■ Operating conditions of hill-start assist control

When the following four conditions are met, the hill-start assist control will operate:

- The shift lever is in a position other than P or N (when starting off forward/backward on an upward incline).
- The vehicle is stopped
- The accelerator pedal is not depressed
- The parking brake is not engaged

■ Automatic system cancelation of hill-start assist control

The hill-start assist control will turn off in any of the following situations:

- The shift lever is shifted to P or N.
- The accelerator pedal is depressed
- The parking brake is engaged
- 2 seconds at maximum elapsed after the brake pedal is released

■ Sounds and vibrations caused by the ABS, brake assist, VSC, TRC and hill-start assist control systems

- A sound may be heard from the engine compartment when the brake pedal is depressed repeatedly, when the hybrid system is started or just after the vehicle begins to move. This sound does not indicate that a malfunction has occurred in any of these systems.
- Any of the following conditions may occur when the above systems are operating. None of these indicates that a malfunction has occurred.
 - Vibrations may be felt through the vehicle body and steering.
 - A motor sound may be heard also after the vehicle comes to a stop.

■ ECB operating sound

ECB operating sound may be heard in the following cases, but it does not indicate that a malfunction has occurred.

- Operating sound heard from the engine compartment when the brake pedal is operated.
- Motor sound of the brake system heard from the front part of the vehicle when the driver's door is opened.
- Operating sound heard from the engine compartment when one or two minutes passed after the stop of the hybrid system.

■ Active Cornering Assist operation sounds and vibrations

When the Active Cornering Assist is operated, operation sounds and vibra-

tions may be generated from the brake system, but this is not a malfunction.

■ EPS operation sound

When the steering wheel is operated, a motor sound (whirring sound) may be heard. This does not indicate a malfunction.

■ Automatic reactivation of TRC and VSC systems

After turning the TRC and VSC systems off, the systems will be automatically re-enabled in the following situations:

- When the power switch is turned off
- If only the TRC system is turned off, the TRC will turn on when vehicle speed increases.
If both the TRC and VSC systems are turned off, automatic re-enabling will not occur when vehicle speed increases.

■ Operating conditions of Active Cornering Assist

The system operates when the following occurs.

- TRC/VSC can operate
- The driver is attempting to accelerate while turning
- The system detects that the vehicle is drifting to the outer side
- The brake pedal is released

■ Reduced effectiveness of the EPS system

The effectiveness of the EPS system is reduced to prevent the system from overheating when there is frequent steering input over an extended period of time. The steering wheel may feel heavy as a result. Should this occur, refrain from excessive steering input or stop the vehicle and turn the hybrid system off. The EPS system should return to normal within 10 minutes.

■ Operating conditions of emergency brake signal

When the following conditions are met, the emergency brake signal will oper-

ates:

- The emergency flashers are off
- Actual vehicle speed is over 55 km/h (35 mph)
- The system judges from the vehicle deceleration that it is a sudden braking operation.

■ **Automatic system cancelation of emergency brake signal**

The emergency brake signal will be canceled in any of the following situations:

- The emergency flashers are turned on.
- The system judges from the vehicle deceleration that is not a sudden braking operation.

■ **Secondary Collision Brake operating cancelation**

The system operates when the SRS air-bag sensor detects a collision while the vehicle is in motion.

However, the system does not operate when components are damaged.

■ **Secondary Collision Brake automatic cancelation**

The system is automatically canceled in any of the following situations.

- The vehicle speed drops approximately 0 km/h (0 mph)
- A certain amount of time elapses during operation
- The accelerator pedal is depressed a large amount



WARNING

■ **The ABS does not operate effectively when**

- The limits of tire gripping performance have been exceeded (such as excessively worn tires on a snow covered road).
- The vehicle hydroplanes while driving at high speed on wet or slick roads.

■ **Stopping distance when the ABS is operating may exceed that of normal conditions**

The ABS is not designed to shorten the vehicle's stopping distance. Always maintain a safe distance from the vehicle in front of you, especially in the following situations:

- When driving on dirt, gravel or snow-covered roads
- When driving with tire chains
- When driving over bumps in the road
- When driving over roads with pot-holes or uneven surfaces

■ **TRC/VSC may not operate effectively when**

Directional control and power may not be achievable while driving on slippery road surfaces, even if the TRC/VSC system is operating. Drive the vehicle carefully in conditions where stability and power may be lost.

■ **Active Cornering Assist does not operate effectively when**

- Do not overly rely on Active Cornering Assist. Active Cornering Assist may not operate effectively when accelerating down slopes or driving on slippery road surfaces.
- When Active Cornering Assist frequently operates, Active Cornering Assist may temporarily stop operating to ensure proper operation of the brakes, TRC and VSC.

■ **Hill-start assist control does not operate effectively when**

- Do not overly rely on hill-start assist control. Hill-start assist control may not operate effectively on steep inclines and roads covered with ice.

**WARNING**

- Unlike the parking brake, hill-start assist control is not intended to hold the vehicle stationary for an extended period of time. Do not attempt to use hill-start assist control to hold the vehicle on an incline, as doing so may lead to an accident.

- **When the TRC/ABS/VSC is activated**

The slip indicator light flashes. Always drive carefully. Reckless driving may cause an accident. Exercise particular care when the indicator light flashes.

- **When the TRC/VSC systems are turned off**

Be especially careful and drive at a speed appropriate to the road conditions. As these are the systems to help ensure vehicle stability and driving force, do not turn the TRC/VSC systems off unless necessary.

- **Replacing tires**

Make sure that all tires are of the specified size, brand, tread pattern and total load capacity. In addition, make sure that the tires are inflated to the recommended tire inflation pressure level.

The ABS, TRC and VSC systems will not function correctly if different tires are installed on the vehicle.

Contact any authorized Toyota retailer or Toyota authorized repairer, or any reliable repairer for further information when replacing tires or wheels.

- **Handling of tires and the suspension**

Using tires with any kind of problem or modifying the suspension will affect the driving assist systems, and may cause a system to malfunction.

- **Secondary Collision Brake**

Do not rely solely upon the Secondary Collision Brake. This system is designed to help reduce the possibility of further damage due to a secondary collision, however, that effect changes according to various conditions. Overly relying on the system may result in death or serious injury.

Hybrid vehicle driving tips

For economical and ecological driving, pay attention to the following points:

Using Eco drive mode

When using Eco drive mode, the torque corresponding to the accelerator pedal depression amount can be generated more smoothly than it is in normal conditions. In addition, the operation of the air conditioning system (heating/cooling) will be minimized, improving the fuel economy. (→P.275)

Use of Hybrid System Indicator

The Eco-friendly driving is possible by keeping the indicate of Hybrid System Indicator within Eco area. (→P.95, 100)

Shift lever operation

Shift the shift lever to D when stopped at a traffic light, or driving in heavy traffic etc. Shift the shift lever to P when parking. When using the N, there is no positive effect on fuel consumption. In the N, the gasoline engine operates but electricity cannot be generated. Also, when using the air conditioning system, etc., the hybrid battery

(traction battery) power is consumed.

Accelerator pedal/brake pedal operation

- Drive your vehicle smoothly. Avoid abrupt acceleration and deceleration. Gradual acceleration and deceleration will make more effective use of the electric motor (traction motor) without having to use gasoline engine power.
- Avoid repeated acceleration. Repeated acceleration consumes hybrid battery (traction battery) power, resulting in poor fuel consumption. Battery power can be restored by driving with the accelerator pedal slightly released.

When braking

Make sure to operate the brakes gently and in a timely manner. A greater amount of electrical energy can be regenerated when slowing down.

Delays

Repeated acceleration and deceleration, as well as long waits at traffic lights, will lead to bad fuel economy. Check traffic reports before leaving and avoid delays as much as possible. When driving in

a traffic jam, gently release the brake pedal to allow the vehicle to move forward slightly while avoiding overuse of the accelerator pedal. Doing so can help control excessive gasoline consumption.

Highway driving

Control and maintain the vehicle at a constant speed. Before stopping at a toll booth or similar, allow plenty of time to release the accelerator and gently apply the brakes. A greater amount of electrical energy can be regenerated when slowing down.

Air conditioning

Use the air conditioning only when necessary. Doing so can help reduce excessive gasoline consumption.

In summer: When the ambient temperature is high, use the recirculated air mode. Doing so will help to reduce the burden on the air conditioning system and reduce fuel consumption as well.

In winter: Because the gasoline engine will not automatically cut out until it and the interior of the vehicle are warm, it will consume fuel. Also, fuel consumption can be improved by avoiding overuse of the heater.

Checking tire inflation pressure

Make sure to check the tire inflation pressure frequently. Improper tire inflation pressure can cause poor fuel economy.

Also, as snow tires can cause large amounts of friction, their use on dry roads can lead to poor fuel economy. Use tires that are appropriate for the season.

Luggage

Carrying heavy luggage will lead to poor fuel economy. Avoid carrying unnecessary luggage. Installing a large roof rack will also cause poor fuel economy.

Warming up before driving

Since the gasoline engine starts up and cuts out automatically when cold, warming up the engine is unnecessary. Moreover, frequently driving short distances will cause the engine to repeatedly warm up, which can lead to excess fuel consumption.

Winter driving tips

Carry out the necessary preparations and inspections before driving the vehicle in winter. Always drive the vehicle in a manner appropriate to the prevailing weather conditions.

Pre-winter preparations

- Use fluids that are appropriate to the prevailing outside temperatures.
 - Engine oil
 - Engine/power control unit coolant
 - Washer fluid
- Have a service technician inspect the condition of the 12-volt battery.
- Have the vehicle fitted with four snow tires or purchase a set of tire chains for the front tires.

Ensure that all tires are the same size and brand, and that chains match the size of the tires.

WARNING

■ Driving with snow tires

Observe the following precautions to reduce the risk of accidents. Failure to do so may result in a loss of vehicle control and cause death or serious injury.

- Use tires of the size specified.
- Maintain the recommended level of air pressure.

- Do not drive at speeds in excess of the speed limit or the speed limit specified for the snow tires being used.

- Use snow tires on all, not just some wheels.

■ Driving with tire chains

Observe the following precautions to reduce the risk of accidents. Failure to do so may result in the vehicle being unable to be driven safely, and may cause death or serious injury.

- Do not drive in excess of the speed limit specified for the tire chains being used, or 50 km/h (30 mph), whichever is lower.

- Avoid driving on bumpy road surfaces or over potholes.

- Avoid sudden acceleration, abrupt steering, sudden braking and shifting operations that cause sudden engine braking.

- Slow down sufficiently before entering a curve to ensure that vehicle control is maintained.

- Do not use LTA (Lane Tracing Assist) system. (if equipped)



NOTICE

■ Repairing or replacing snow tires

Request repairs or replacement of snow tires from any authorized Toyota retailer or Toyota authorized repairer, or any reliable repairer or legitimate tire retailers.

This is because the removal and attachment of snow tires affects the operation of the tire pressure warning valves and transmitters.

Before driving the vehicle

Perform the following according to

the driving conditions:

- Do not try to forcibly open a window or move a wiper that is frozen. Pour warm water over the frozen area to melt the ice. Wipe away the water immediately to prevent it from freezing.
- To ensure proper operation of the climate control system fan, remove any snow that has accumulated on the air inlet vents in front of the windshield.
- Check for and remove any excess ice or snow that may have accumulated on the exterior lights, vehicle's roof, chassis, around the tires or on the brakes.
- Remove any snow or mud from the bottom of your shoes before getting in the vehicle.

When driving the vehicle

Accelerate the vehicle slowly, keep a safe distance between you and the vehicle ahead, and drive at a reduced speed suitable to road conditions.

When parking the vehicle

- Park the vehicle and shift the shift lever to P without setting the parking brake. The parking brake may freeze up, preventing it from being released. If the vehicle is parked without setting the parking brake, make sure to block the wheels.

Failure to do so may be dangerous because it may cause the vehicle to move unexpectedly, possibly leading to an accident.

- If the vehicle is parked without setting the parking brake, confirm that the shift lever cannot be moved out of P*.

*: The shift lever will be locked if it is attempted to be shifted from P to any other position without depressing the brake pedal. If the shift lever can be shifted from P, there may be a problem with the shift lock system. Have the vehicle inspected by any authorized Toyota retailer or Toyota authorized repairer, or any reliable repairer or legitimate tire retailers immediately.

Selecting tire chains

Use the correct tire chain size when mounting the tire chains.

Chain size is regulated for each tire size.

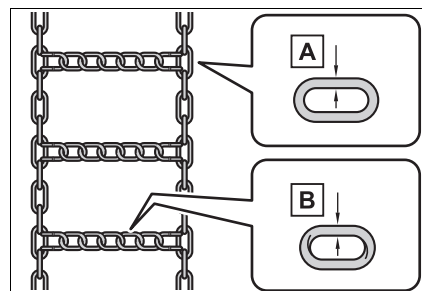

A Side chain (3 mm [0.12 in.] in diameter)

B Cross chain (4 mm [0.16 in.] in diameter)

Regulations on the use of tire chains

Regulations regarding the use of tire chains vary depending on location and type of road. Always check local regulations before installing chains.

■ Tire chain installation

Observe the following precautions when installing and removing chains:

- Install and remove tire chains in a safe location.
- Install tire chains on the front tires only. Do not install tire chains on the rear tires.
- Install tire chains on the front tires as tightly as possible. Retighten chains after driving 0.5—1.0 km (1/4—1/2 mile).
- Install tire chains following the instructions provided with the tire chains.



NOTICE

■ Fitting tire chains

The tire pressure warning valves and transmitters may not function correctly when tire chains are fitted.

Interior features**5**

- 5-1. Using the air conditioning system and defogger**
 - Automatic air conditioning system**288**
 - Heated steering wheel/seat heaters**293**
- 5-2. Using the interior lights**
 - Interior lights list.....**295**
- 5-3. Using the storage features**
 - List of storage features**297**
 - Luggage compartment features**299**
- 5-4. Other interior features**
 - Other interior features.....**303**

Automatic air conditioning system

Air outlets are automatically selected and fan speed is automatically adjusted according to the set temperature setting.

The illustrations below are for left-hand drive vehicles.

The button positions and shapes will differ for right-hand drive vehicles.

Also, the display and button positions will differ depending on the type of the system.

Air conditioning controls

- ▶ Vehicles with the DUAL mode

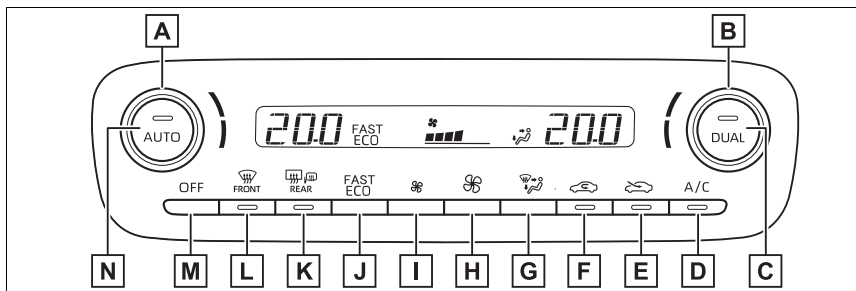

- ▶ Vehicles without the DUAL mode

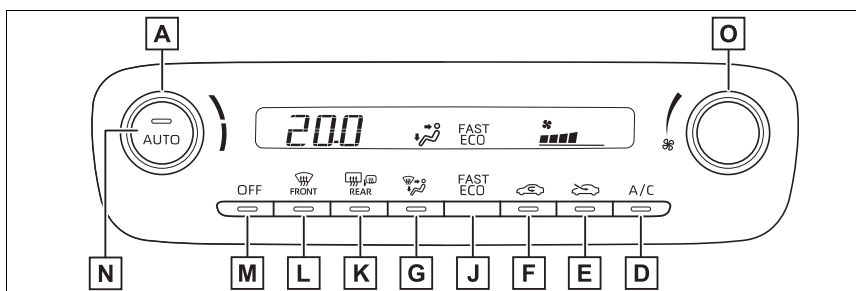

- A** Driver side temperature control dial
- B** Passenger side temperature control dial
- C** "DUAL" switch
- D** "A/C" switch
- E** Outside air mode switch

- F** Recirculated air mode switch
- G** Airflow mode control switch
- H** Fan speed increases switch
- I** Fan speed decreases switch
- J** “FAST/ECO” switch
- K** Rear window defogger and outside rear view mirror defoggers switch
- L** Windshield defogger switch
- M** Off switch
- N** Automatic mode switch
- O** Fan speed control dial

■ Adjusting the temperature setting

To adjust the temperature setting, turn the temperature control dial clockwise (warm) or counterclockwise (cool).

If “A/C” switch is not pressed, the system will blow ambient temperature air or heated air.

■ Setting the fan speed

▶ Vehicles with the DUAL mode

Operate the fan speed increases switch to increase the fan speed and the fan speed decreases switch to decrease the fan speed.

Pressing the off switch to turns off the fan.

▶ Vehicles without the DUAL mode

To adjust the fan speed, turn the fan speed control dial clockwise (increase) or counterclockwise (decrease).

■ Change the airflow mode

Press the airflow mode control switch.

The airflow mode changes as follows each time the switch is pressed.

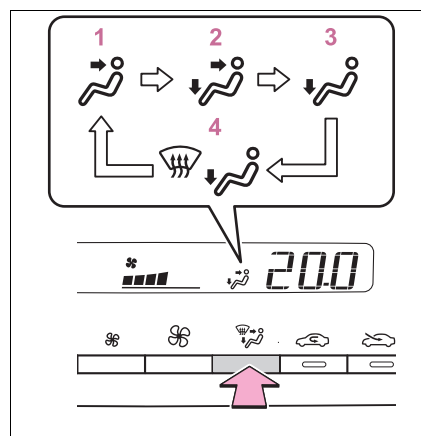

- 1** Upper body
- 2** Upper body and feet
- 3** Feet
- 4** Feet and the windshield defogger operates

■ **Switching between outside air and recirculated air modes**

- To change to recirculated air mode, press the recirculated air mode switch.

The indicator illuminates on the recirculated air mode switch.

- To change to outside air mode, press the outside air mode switch.

The indicator illuminates on the outside air mode switch.

■ **Set cooling and dehumidification function**

Press the "A/C" switch.

When the function is on, the indicator illuminates on the "A/C" switch.

■ **Defogging the windshield**

Defoggers are used to defog the windshield and front side windows.

Press the windshield defogger switch.

Set the outside/recirculated air mode switch to outside air mode if the recirculated air mode is used. (It may switch automatically.)

To defog the windshield and the side windows quickly, turn the air flow and temperature up.

To return to the previous mode, press the windshield defogger switch again when the windshield is defogged.

When the windshield defogger switch is on, the indicator illuminates on the windshield defogger switch.

■ **Defogging the rear window and outside rear view mirrors**

Defoggers are used to defog the rear window, and to remove raindrops, dew and frost from the outside rear view mirrors.

Press the rear window and outside rear view mirror defoggers switch.

The defoggers will automatically turn off after a while.

When the rear window and outside rear view mirror defoggers switch is on, the indicator illuminates on the rear window and outside rear view mirror defoggers switch.

■ **Using the Climate Preference**

- 1 Press the automatic mode switch.
- 2 Press the "FAST/ECO" switch.

Each time the "FAST/ECO" switch is pressed, the fan speed setting mode toggles as follows.

Normal → "ECO" → "FAST" → Normal

When "ECO" is displayed on the air conditioning screen, the air conditioning is controlled with low fuel consumption prioritized such as reducing fan speed, etc.

When "FAST" is displayed on the screen, fan speed will be increased.

■ **Fogging up of the windows**

- The windows will easily fog up when the humidity in the vehicle is high. Turning "A/C" on will dehumidify the air from the outlets and defog the

windshield effectively.

- If you turn "A/C" off, the windows may fog up more easily.
- The windows may fog up if the recirculated air mode is used.

■ When driving on dusty roads

Close all windows. If dust thrown up by the vehicle is still drawn into the vehicle after closing the windows, it is recommended that the air intake mode be set to outside air mode and the fan speed to any setting except off.

■ Outside/recirculated air mode

- Setting to the recirculated air mode temporarily is recommended in preventing dirty air from entering the vehicle interior and helping to cool the vehicle when the outside air temperature is high.
- Outside/recirculated air mode may automatically switch depending on the temperature setting or the inside temperature.

■ Operation of the air conditioning system in Eco drive mode

- In Eco drive mode, the air conditioning system is controlled as follows to prioritize fuel efficiency:
 - Engine speed and compressor operation controlled to restrict heating/cooling capacity
 - Fan speed restricted when automatic mode is selected
- To improve air conditioning performance, perform the following operations:
 - Adjust the fan speed
 - Turn off Eco drive mode (→P.275)
- Even when the drive mode is set to Eco drive mode, the air conditioning eco mode can be turned off by pressing the "FAST/ECO" switch. (→P.290)

■ When the outside temperature falls to nearly 0°C (32°F)

The dehumidification function may not operate even when "A/C" switch is pressed.

■ Ventilation and air conditioning odors

- To let fresh air in, set the air conditioning system to the outside air mode.
- During use, various odors from inside and outside the vehicle may enter into and accumulate in the air conditioning system. This may then cause odor to be emitted from the vents.
- To reduce potential odors from occurring:
 - It is recommended that the air conditioning system be set to outside air mode prior to turning the vehicle off.
 - The start timing of the blower may be delayed for a short period of time immediately after the air conditioning system is started in automatic mode.
- When parking, the system automatically switches to outside air mode to encourage better air circulation throughout the vehicle, helping to reduce odors that occur when starting the vehicle.

■ Air conditioning filter

→P.346

■ Customization

Some functions can be customized. (→P.431)

WARNING

■ To prevent the windshield from fogging up

Do not use the windshield defogger switch during cool air operation in extremely humid weather. The difference between the temperature of the outside air and that of the windshield can cause the outer surface of the windshield to fog up, blocking your vision.

■ When the outside rear view mirror defoggers are operating

Do not touch the outside rear view mirror surfaces, as they can become very hot and burn you.



NOTICE

■ **To prevent 12-volt battery discharge**

Do not leave the air conditioning system on longer than necessary when the hybrid system is off.

Using automatic mode

- 1 Press the automatic mode switch.
- 2 Adjust the temperature setting.
- 3 To stop the operation, press the off switch.

If the fan speed setting or air flow modes are operated, the automatic mode indicator goes off. However, automatic mode for functions other than that operated is maintained.

■ **Using automatic mode**

Fan speed is adjusted automatically according to the temperature setting and the ambient conditions.

Therefore, the fan may stop for a while until warm or cool air is ready to flow immediately after the automatic mode switch pressed.

Adjusting the temperature for the driver and front passenger seat separately (if equipped)

To turn on the “DUAL” mode, perform any of the following procedures:

- Press the “DUAL” switch.
- Adjust the front passenger’s side temperature setting.

The indicator on the “DUAL” switch comes on when the “DUAL” mode is on.

Pressing the “DUAL” switch when in “DUAL” mode will disable “DUAL” mode, and the temperature setting for the front passenger’s side will become linked to the driver’s side.

Air outlet layout and operations

■ **Location of air outlets**

The air outlets and air volume changes according to the selected air flow mode.

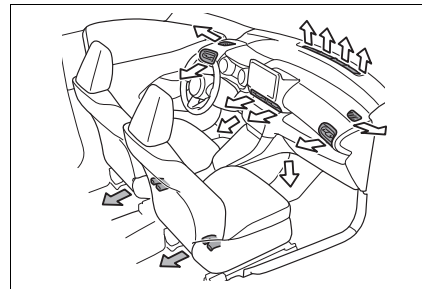

←: If equipped

■ **Adjusting the position of and opening and closing the air outlets**

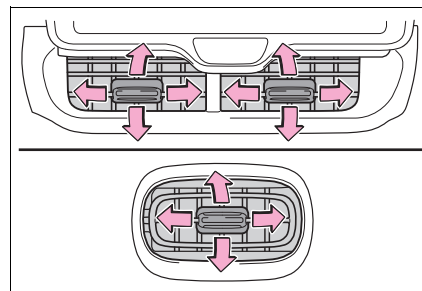

Direct air flow to the left or right, up

or down

Center outlets: Move the knob fully to the left-side to close the vent.

Side outlets: Move the knob fully to the outside to close the vent.

! WARNING

■ To prevent the windshield defogger from operating improperly

Do not place anything on the instrument panel which may cover the air outlets. Otherwise, air flow may be obstructed, preventing the windshield defoggers from defogging.

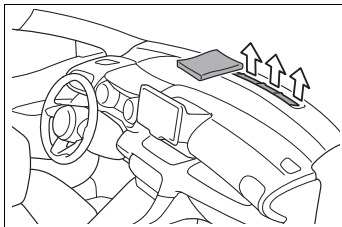

Heated steering wheel* / seat heaters*

*: If equipped

● Heated steering wheel

Warms up the grip of the steering wheel

● Seat heaters

Warm up the seat upholstery

! WARNING

■ To prevent minor burn injuries

Care should be taken if anyone in the following categories comes in contact with the steering wheel or seats when the heater is on:

- Babies, small children, the elderly, the sick and the physically challenged
- Persons with sensitive skin
- Persons who are fatigued
- Persons who have taken alcohol or drugs that induce sleep (sleeping drugs, cold remedies, etc.)

! NOTICE

■ To prevent damage to the seat heaters

Do not put heavy objects that have an uneven surface on the seat and do not stick sharp objects (needles, nails, etc.) into the seat.

■ To prevent 12-volt battery discharge

Do not use the functions when the hybrid system is off.

Operation instructions

■ **Heated steering wheel**

Turns heated steering wheel on/off

When the heated steering wheel is on, the indicator illuminates on the heated steering wheel switch.

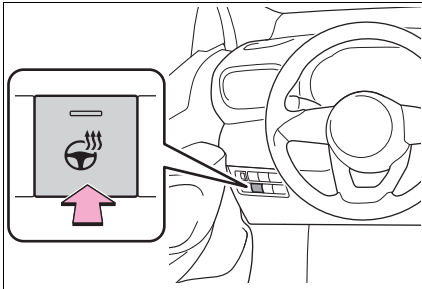

■ **Seat heaters**

Turns seat heaters on/off

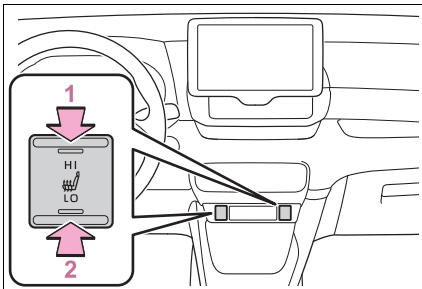

1 High temperature

2 Low temperature

When the seat heater is on, the indicator illuminates on the seat heater switch.

When not in use, put the switch in the neutral position. The indicator will turn off.

■ **The heated steering wheel and seat heaters can be used when**

The power switch is in ON.

! WARNING

■ **To prevent overheating and minor burn injuries**

Observe the following precautions when using the seat heaters.

- Do not cover the seat with a blanket or cushion when using the seat heater.
- Do not use seat heater more than necessary.

Interior lights list

Location of the interior lights

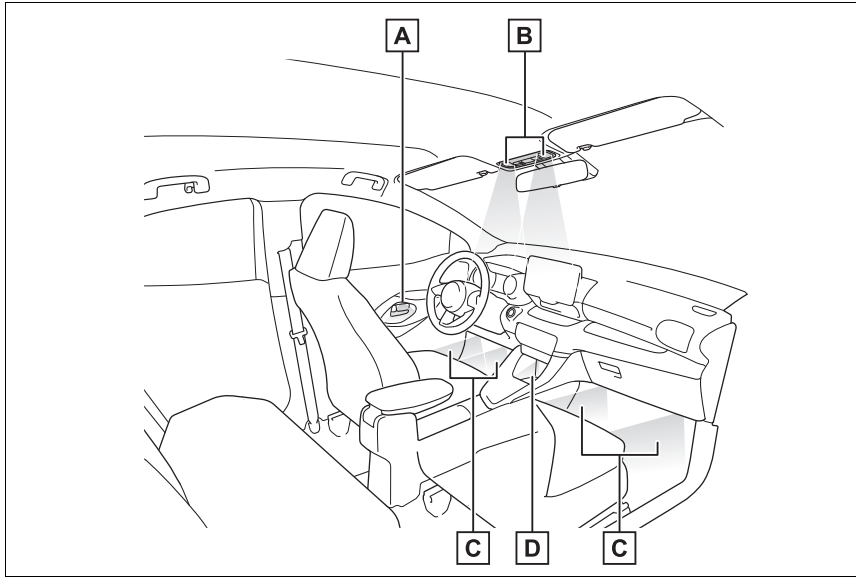

- A** Door trim lights (if equipped)
- B** Interior/personal lights (→P.295, 296)
- C** Footwell lights (if equipped)
- D** Front console lights

Operating the interior lights

When a door is opened while the door position is on, the lights turn on.

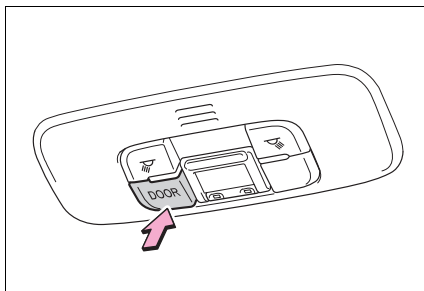

Turns the door position on/off

Operating the personal lights

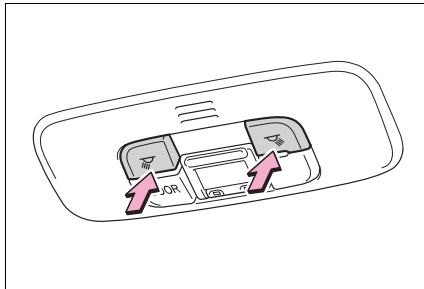

Turns the lights on/off



NOTICE

■ To prevent 12-volt battery discharge

Do not leave the lights on longer than necessary when the hybrid system is off.

■ Illuminated entry system

The lights automatically turn on/off according to the power switch mode, the presence of the electronic key (vehicles with entry function), whether the doors are locked/unlocked, and whether the doors are opened/closed.

■ To prevent the 12-volt battery from being discharged

If the interior lights remain on when the power switch is turned off, the lights will go off automatically after 20 minutes.

■ The interior lights may turn on automatically when

If any of the SRS airbags deploy (inflate) or in the event of a strong rear impact, the interior lights will turn on automatically.

The interior lights will turn off automatically after approximately 20 minutes.

The interior lights can be turned off manually. However, in order to help prevent further collisions, it is recommended that they be left on until safety can be ensured.

(The interior lights may not turn on automatically depending on the force of the impact and conditions of the collision.)

■ Customization

Some functions can be customized.
(→P.431)

List of storage features

Location of the storage features

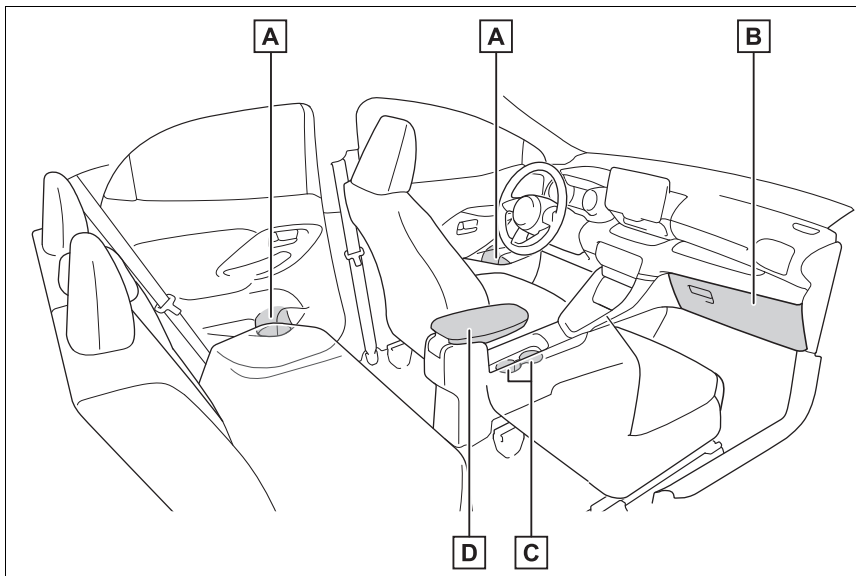

- A** Bottle holders (→P.298)
- B** Glove box (→P.298)
- C** Cup holders (→P.298)
- D** Console box (→P.299)

WARNING

■ **Items that should not be left in the storage spaces**

Do not leave glasses, lighters or spray cans in the storage spaces, as this may cause the following when cabin temperature becomes high:

- Glasses may be deformed by heat or cracked if they come into contact with other stored items.

- Lighters or spray cans may explode. If they come into contact with other stored items, the lighter may catch fire or the spray can may release gas, causing a fire hazard.

Glove box

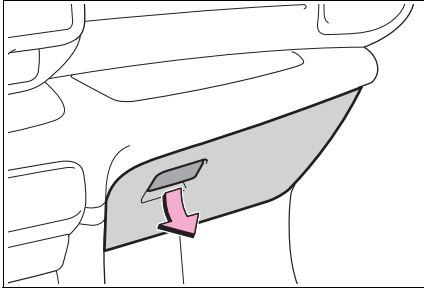

Pull up the lever to open the glove box.

! WARNING

■ Caution while driving

Keep the glove box closed. In the event of sudden braking or sudden swerving, an accident may occur due to an occupant being struck by the open glove box or the items stored inside.

Cup holders

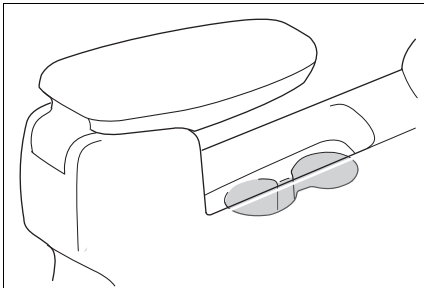

! WARNING

■ Items unsuitable for the cup holder

Do not place anything other than cups or beverage cans in the cup holders. Other items may be thrown out of the holders in the event of an accident or sudden braking and cause injury. If possible, cover hot drinks to prevent burns.

Bottle holders

► Front

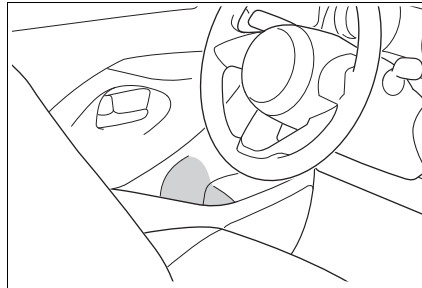

► Rear

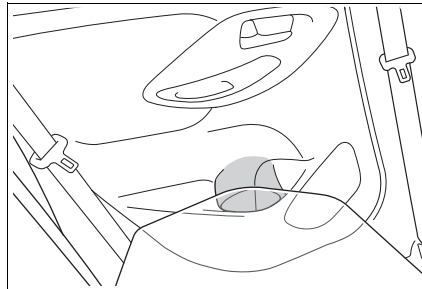

■ Bottle holders

- When storing a bottle, close the cap.
- The bottle may not be stored depending on its size or shape.

! WARNING**■ Items unsuitable for the bottle holders**

Do not place anything other than a bottle in the bottle holders. Other items may be thrown out of the holders in the event of an accident or sudden braking and cause injury.

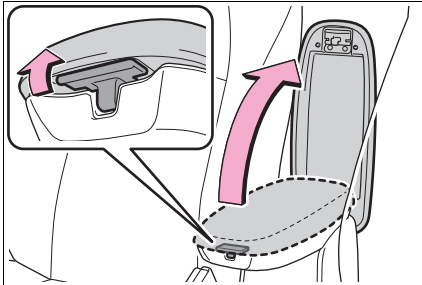
Console box

Lift the lid while pulling up the knob.

■ When not in use

The console box can be raised to reveal a secondary console box.

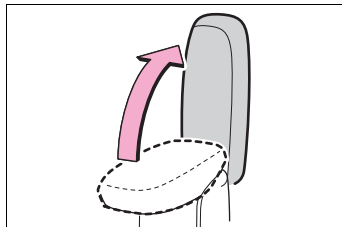
**! WARNING****■ Caution while driving**

Keep the console box closed. Injuries may result in the event of an accident or sudden braking.

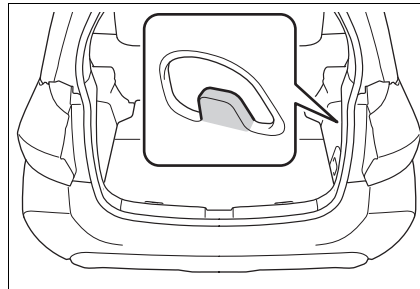
Luggage compartment features**Grocery bag hooks****! WARNING****■ To prevent damage to the grocery bag hooks**

Do not hang any object heavier than 2 kg (4.4 lb.) on the grocery bag hooks.

Deck board (if equipped)**■ Opening the deck board**

Open the deck board.

The deck board can be set up as shown in the illustration.

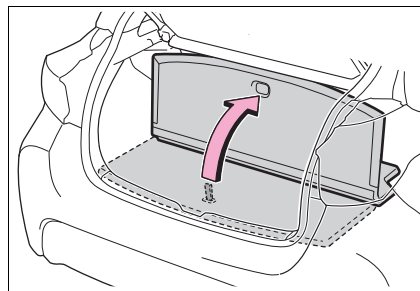

■ **Removing the deck board**

- 1 Fold the deck board.

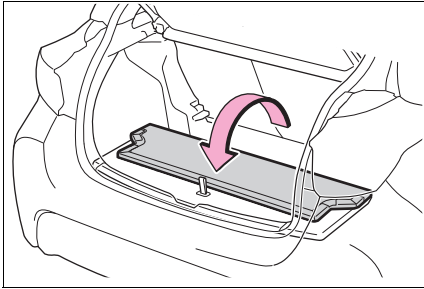

- 2 Slide the deck board to the front of the vehicle.

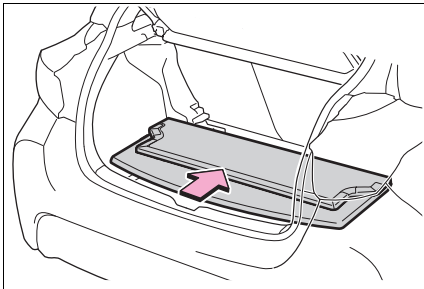

- 3 Remove the deck board diagonally.

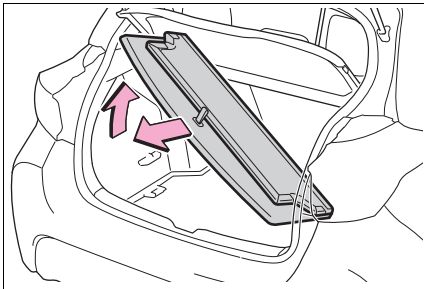

■ **Installing the deck board**

- 1 Fold the deck board.

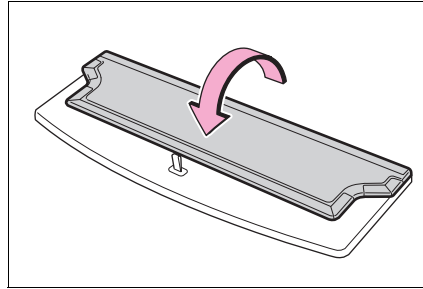

- 2 Insert the deck board diagonally.

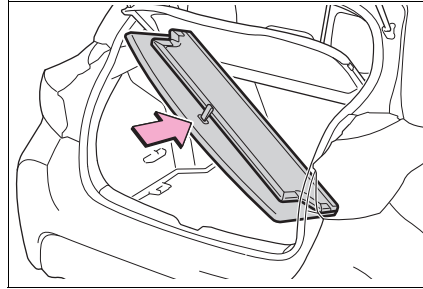

- 3 Slide the deck board to the rear of the vehicle.

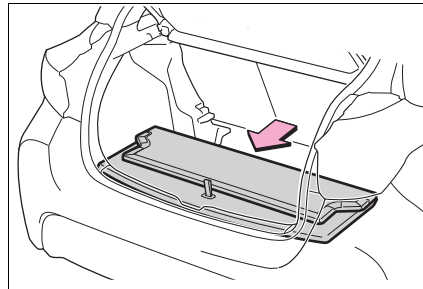

4 Unfold the deck board.

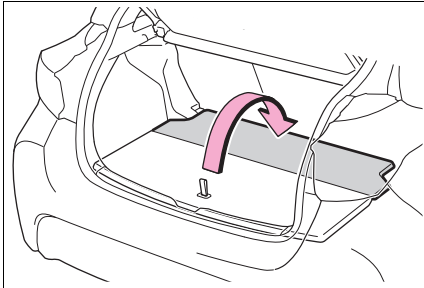

■ **Changing the height of the luggage compartment floor**

By changing the position of the deck board, the height of the luggage compartment floor can be changed.

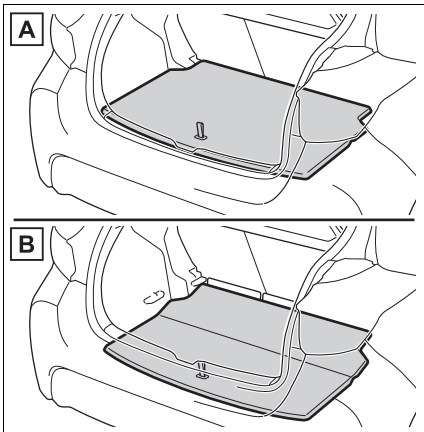

A Upper position

B Lower position

Auxiliary box

Open the deck board.

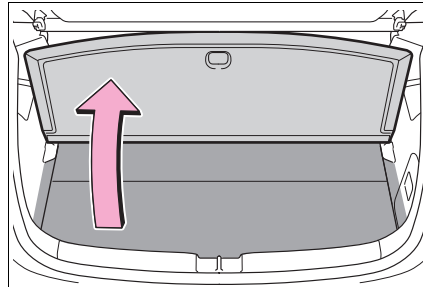

Open the floor cover.

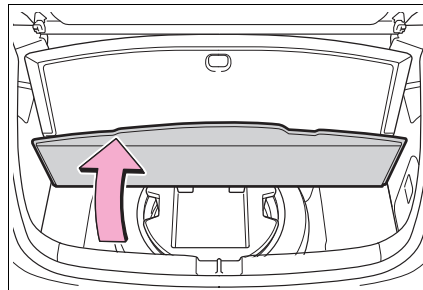

► Type A

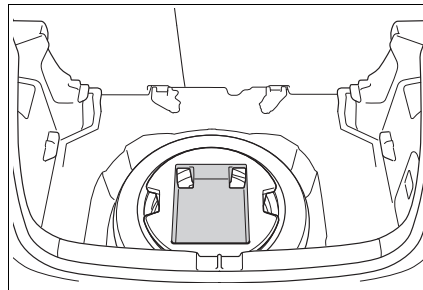

► Type B

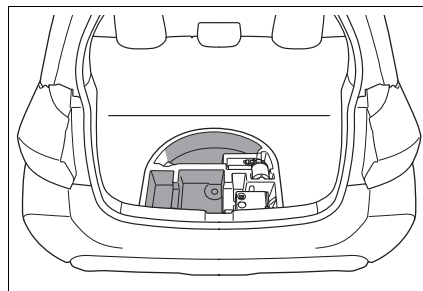

Removing the tonneau cover (if equipped)

- 1 Unhook the cords.

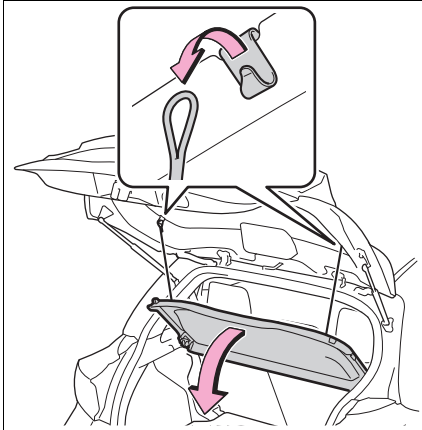

- 2 Unhook and remove the tonneau cover.

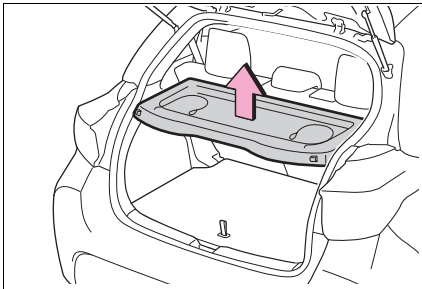

Stowing the tonneau cover (if equipped)

Tonneau cover can be stowed to the rear seats.

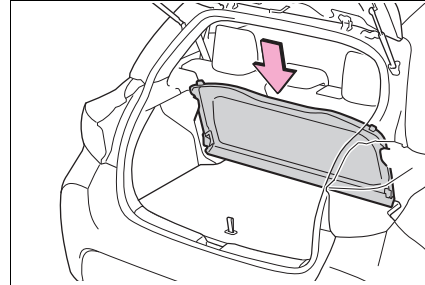

Other interior features

Power outlet

The power outlet can be used for 12 V accessories that run on less than 10 A.

Open the lid.

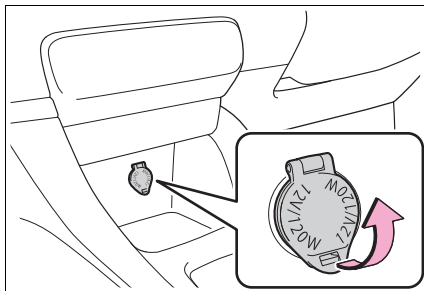

■ **The power outlet can be used when**

The power switch is in ACC or ON.

■ **When stopping the hybrid system**

Disconnect electrical devices with charging functions, such as mobile battery packs.

If such devices are left connected, the hybrid system may not stop normally.

 **NOTICE**

■ **To prevent the fuse from being blown**

Do not use an accessory that uses more than 12 V 10 A.

■ **To avoid damaging the power outlet**

Close the power outlet lid when the power outlet is not in use. Foreign objects or liquids that enter the power outlet may cause a short circuit.

■ **To prevent 12-volt battery discharged**

Do not use the power outlet longer than necessary when the hybrid system is off.

Wireless charger (if equipped)

A portable device, such as a smartphone or mobile battery, can be charged by just placing it on the charging area, provided the device is compatible with the Qi wireless charging standard created by the Wireless Power Consortium.

The wireless charger cannot be used with a portable device that is larger than the charging area. Additionally, depending on the portable device, the wireless charger may not operate properly. Refer to the operation manual of the portable device.

■ **The “Qi” symbol**

The “Qi” symbol is a trademark of the Wireless Power Consortium.



■ Name for all parts

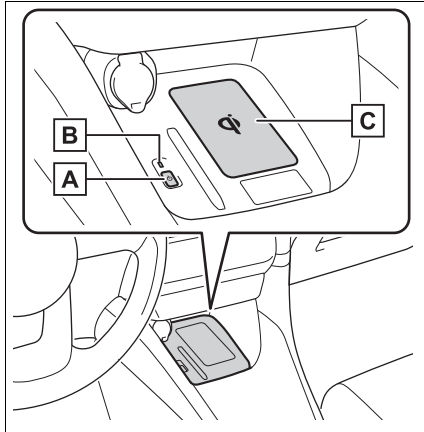

- A** Power supply switch
- B** Operation indicator light
- C** Charge area

■ Using the wireless charger

- 1 Press the power supply switch of the wireless charger.

Pressing the switch again turns the wireless charger off.
 When turned on, the operation indicator light (green) comes on.
 When the power switch is turned off, the on/off state of the wireless charger will be memorized.

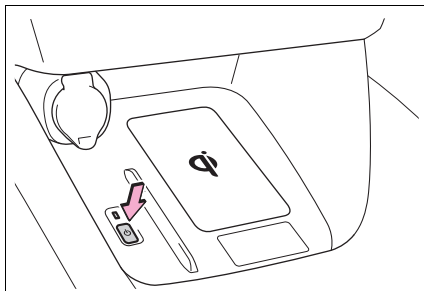

- 2 Place a portable device on the charging area with its charging surface facing down.

While charging, the operation indicator light (orange) will be illuminated.
 If charging does not begin, move the portable device as close to the center of the charging area as possible.
 When charging is complete, the operation indicator light (green) will illuminate.

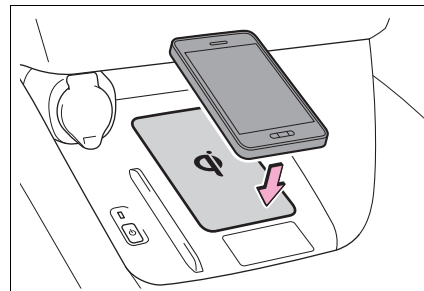

■ Recharging function

- If a certain amount of time has elapsed since charging completed and the portable device has not been moved, the wireless charger will restart charging.
- If the portable device is moved within the charging area, charging will stop temporarily then restart.

■ **Operation indicator light status**

Operation indicator light	State
Off	The Wireless charger is off
Green (illuminated)	Standby (charging is possible)
	Charging is complete *
Orange (illuminated)	A portable device has been placed on the charging area (identifying the portable device)
	Charging in progress

* : Depending on the portable device, the operation indicator light may stay illuminated (orange) after charging has completed.

● **If the operation indicator light blinks**

If an error is detected, the operation indicator light will blink (orange). Take the appropriate measures according to the table below.

Operation indicator light	Suspected cause	Measure
Blinks (orange) at a one second interval continuously	Vehicle to charger communication failure.	Contact any authorized Toyota retailer or Toyota authorized repairer, or any reliable repairer.
Blinks (orange) 3 times repeatedly	A foreign object exists between the portable device and charging area.	Remove the foreign object.
	Portable device is not positioned properly on the charging area.	Move the portable device toward the center of the charging area.
Blinks (orange) 4 times repeatedly	The temperature of the wireless charger is excessively high.	Stop charging immediately and continue charging after a while.

■ **The wireless charger can be operated when**

The power switch is in ACC or ON.

■ **Portable devices that can be charged**

- Portable devices compatible with the Qi wireless charging standard can be charged by the wireless charger. However, compatibility with all devices which meet the Qi wireless charging

standard is not guaranteed.

- The wireless charger is designed to supply low power electricity (5 W or less) to a cellular phone, smartphone, or other portable device.

■ **If a cover or accessory is attached to the portable device**

Do not charge a portable device if a cover or accessory which is not Qi compatible is attached. Depending on the

type of cover and/or accessory attached, it may not be possible to charge the portable device. If the portable device is placed on the charging area and does not charge, remove the cover and/or accessories.

■ **If interference is heard in AM radio broadcasts while charging**

Turn off the wireless charger and check if the noise is reduced. If noise is reduced, press and hold the power supply switch of the wireless charger for 2 seconds. The frequency of the wireless charger is changed and noise may be reduced. When the frequency is changed, the operation indicator light will blink (orange) 2 times.

■ **Charging precautions**

- If the electronic key cannot be detected in the cabin, charging cannot be performed. When a door is opened and closed, charging may be temporarily suspended.
- While charging, the wireless charger and the portable device will become warm.
This is not a malfunction. If a portable device becomes warm while charging and charging stops due to the protection function of the portable device, wait until the portable device cools down and charge it again.

■ **Sound generated during operation**

When the power supply switch is turned on or while a portable device is being identified, operation sounds may be heard. This is not a malfunction.

■ **Cleaning the wireless charger**

→P.315

 **WARNING**

■ **Caution while driving**

When charging a portable device while driving, for safety reasons, the driver should not operate the portable device.

■ **Caution regarding interference with electronic devices**

People with implantable cardiac pacemakers, cardiac resynchronization therapy pacemakers or implantable cardioverter defibrillators, as well as any other electrical medical device, should consult their physician about the usage of the wireless charger. Operations of the wireless charger may have an affect on medical devices.

■ **To prevent damage or burns**

Observe the following precautions. Failure to do so may result in the possibility of fire, equipment failure or damage, or burns due to heat.

- Do not put any metallic objects between the charging area and the portable device while charging.
- Do not attach metallic objects, such as aluminum stickers, to the charging area.
- Do not cover the wireless charger with a cloth or other object while charging.
- Do not attempt to charge portable devices which are not compatible with the Qi wireless charging standard.
- Do not disassemble, modify or remove the wireless charger.
- Do not apply force or impact to the wireless charger.

 **NOTICE**

■ **Conditions in which the wireless charger may not operate correctly**

In the following situations, the wireless charger may not operate correctly:

- When a portable device is fully charged

**NOTICE**

- When there is a foreign object between the charging area and portable device
- When a portable device becomes hot while charging
- When a portable device is placed on the wireless area with its charging surface facing up
- When a portable device is not centered on the charging area
- When the vehicle is near a TV tower, electric power plant, gas station, radio station, large display, airport or other facility that generates strong radio waves or electrical noise
- When the portable device is in contact with, or is covered by any of the following metallic objects:
 - Cards to which aluminum foil is attached
 - Cigarette boxes that have aluminum foil inside
 - Metallic wallets or bags
 - Coins
 - Metal hand warmers
 - Media such as CDs and DVDs
- When wireless keys (that emit radio waves) other than those of your vehicle are being used nearby.

If in situations other than above the wireless charger does not operate properly or the operation indicator light is blinking, the wireless charger may be malfunctioning. Contact any authorized Toyota retailer or Toyota authorized repairer, or any reliable repairer.

■ To prevent failure or damage to data

- Do not bring magnetic cards, such as a credit card, or magnetic recording media, close to the wireless charger while charging. Otherwise, data may be erased due to the influence of magnetism. Additionally, do not bring precision instruments such as wrist watches, close to the wireless charger, as such objects may malfunction.
- Do not leave portable devices in the cabin. The temperature inside the cabin may become high when parked in the sun, and cause damage to the device.

■ To prevent 12-volt battery discharge

Do not use the wireless charger for a long period of time with the hybrid system stopped.

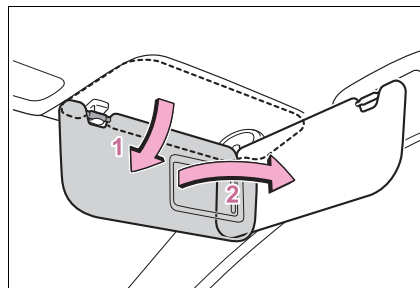
Sun visors

- 1** To set the visor in the forward position, flip it down.
- 2** To set the visor in the side position, flip down, unhook, and swing it to the side.

Vanity mirrors (if equipped)

Slide the cover to open.

The vanity light turns on. (if equipped)

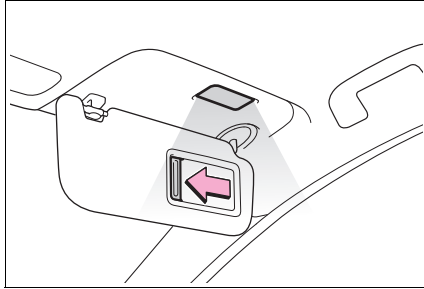

To prevent 12-volt battery discharge

If the vanity lights remain on when the power switch is OFF, the lights will go off automatically after 20 minutes.

NOTICE

To prevent the 12-volt battery from being discharged

Do not leave the vanity lights on for extended periods while the hybrid system is off.

Assist grips

An assist grip installed on the ceiling can be used to support your body while sitting on the seat.

► Front

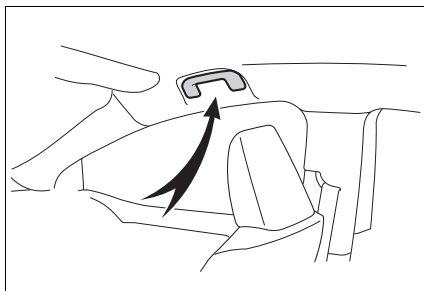

► Rear (if equipped)

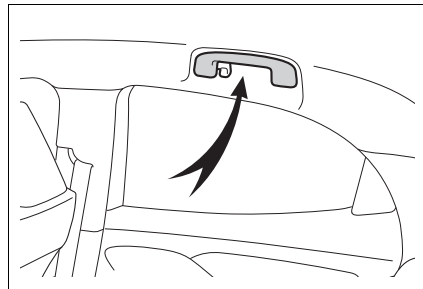

WARNING

Assist grip

Do not use the assist grip when getting in or out of the vehicle or rising from your seat.

NOTICE

To prevent damage to the assist grip

Do not hang any heavy object or put a heavy load on the assist grip.

Coat hooks

The coat hooks are provided with the rear assist grips.

► Type A

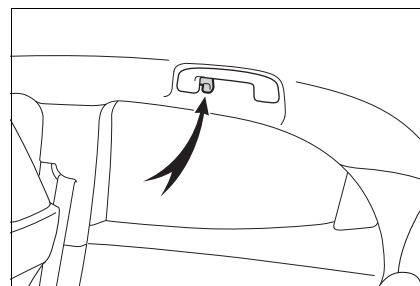

► Type B

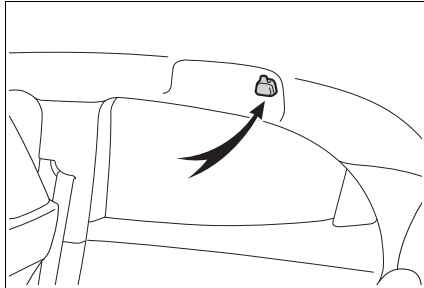

⚠ WARNING

■ **Items that cannot be hung on the coat hook**

Do not hang coat hangers or other hard or sharp objects on the hook. If the SRS curtain shield airbags deploy, these items may become projectiles, causing death or serious injury.

Panoramic roof shade (if equipped)

The panoramic roof shade can be opened and closed manually.

■ **Opening the panoramic roof shade**

Pushing the tabs will release the lock, and the shade can be opened.

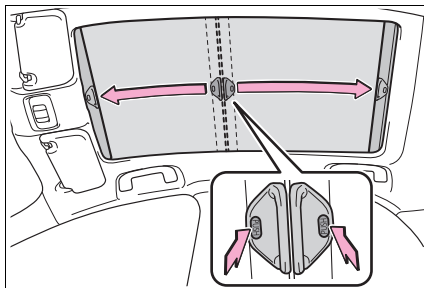

■ **Closing the panoramic roof shade**

Pull the tabs to the lock position to

close the shade.

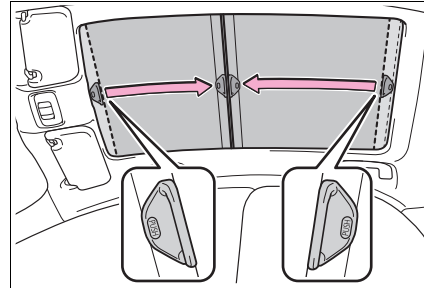

Maintenance and care**6****6-1. Maintenance and care**

Cleaning and protecting the
vehicle exterior **312**

Cleaning and protecting the
vehicle interior **315**

6-2. Maintenance

Maintenance requirements **318**

6-3. Do-it-yourself maintenance

Do-it-yourself service precau-
tions **320**

Hood **322**

Positioning a floor jack..... **323**

Engine compartment **325**

12-volt battery **330**

Tires **332**

Tire inflation pressure **342**

Wheels **344**

Air conditioning filter **346**

Cleaning the hybrid battery
(traction battery) air intake
vent and filter **348**

Wireless remote control/elec-
tronic key battery **351**

Checking and replacing fuses
..... **354**

Light bulbs **357**

Cleaning and protecting the vehicle exterior

Perform cleaning in a manner appropriate to each component and its material.

Cleaning instructions

- Working from top to bottom, liberally apply water to the vehicle body, wheel wells and underside of the vehicle to remove any dirt and dust.
- Wash the vehicle body using a sponge or soft cloth, such as a chamois.
- For hard-to-remove marks, use car wash soap and rinse thoroughly with water.
- Wipe away any water.
- Wax the vehicle when the water-proof coating deteriorates.

If water does not bead on a clean surface, apply wax when the vehicle body is cool.

Automatic car washes

- Before washing the vehicle:
 - Fold the mirrors.

Start washing from the front of the vehicle. Extend the mirrors before driving.

- Brushes used in automatic car washes may scratch the vehicle surface, parts (wheel, etc.) and harm your vehicle's paint.
- In certain automatic car washes, the rear spoiler (if equipped) may interfere with machine operation. This may prevent the vehicle from being cleaned

properly or result in damage to the rear spoiler.

High pressure car washes

As water may enter the cabin, do not bring the nozzle tip near the gaps around the doors or perimeter of the windows, or spray these areas continuously.

When using a car wash (vehicles with a smart entry & start system)

If the door handle becomes wet while the electronic key is within the effective range, the door may lock and unlock repeatedly. In that case, follow the following correction procedures to wash the vehicle:

- Place the key in a position 2 m (6 ft.) or more separate from the vehicle while the vehicle is being washed. (Take care to ensure that the key is not stolen.)
- Set the electronic key to battery-saving mode to disable the smart entry & start system. (→P.141)

Wheels and wheel ornaments (if equipped)

- Remove any dirt immediately by using a neutral detergent.
- Wash detergent off with water immediately after use.
- To protect the paint from damage, make sure to observe the following precautions.
 - Do not use acidic, alkaline or abrasive detergent
 - Do not use hard brushes
 - Do not use detergent on the wheels when they are hot, such as after driving or parking in hot weather

Bumpers

Do not scrub with abrasive cleaners.

Plated portions (if equipped)

If dirt cannot be removed, clean the parts as follows:

- Use a soft cloth dampened with an approximately 5% solution of neutral detergent and water to clean the dirt

off.

- Wipe the surface with a dry, soft cloth to remove any remaining moisture.
- To remove oily deposits, use alcohol wet wipes or a similar product.

WARNING

■ When washing the vehicle

Do not apply water to the inside of the engine compartment. Doing so may cause the electrical components, etc. to catch fire.

■ When cleaning the windshield (vehicles with rain-sensing windshield wipers)

Set the wiper switch to off. If the wiper switch is in "AUTO", the wipers may operate unexpectedly in the following situations, and may result in hands being caught or other serious injuries and cause damage to the wiper blades.

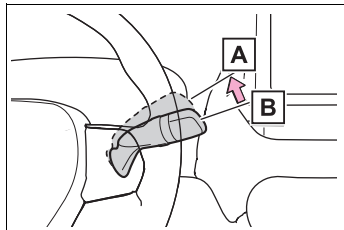

A Off

B AUTO

- When the upper part of the windshield where the raindrop sensor is located is touched by hand
- When a wet rag or similar is held close to the raindrop sensor
- If something bumps against the windshield
- If you directly touch the raindrop sensor body or if something bumps into the raindrop sensor

■ Precautions regarding the exhaust pipe

Exhaust gasses cause the exhaust pipe to become quite hot. When washing the vehicle, be careful not to touch the pipe until it has cooled sufficiently, as touching a hot exhaust pipe can cause burns.

■ Precaution regarding the rear bumper with Blind Spot Monitor (if equipped)

If the paint of the rear bumper is chipped or scratched, the system may malfunction. If this occurs, consult with any authorized Toyota retailer or Toyota authorized repairer, or any reliable repairer.

NOTICE

■ To prevent paint deterioration and corrosion on the body and components (aluminum wheels, etc.)

- Wash the vehicle immediately in the following cases:
 - After driving near the sea coast
 - After driving on salted roads
 - If coal tar or tree sap is present on the paint surface
 - If dead insects, insect droppings or bird droppings are present on the paint surface
 - After driving in an area contaminated with soot, oily smoke, mine dust, iron powder or chemical substances
 - If the vehicle becomes heavily soiled with dust or mud
 - If liquids such as benzene and gasoline are spilled on the paint surface
- If the paint is chipped or scratched, have it repaired immediately.



NOTICE

- To prevent the wheels from corroding, remove any dirt and store in a place with low humidity when storing the wheels.

■ Cleaning the exterior lights

- Wash carefully. Do not use organic substances or scrub with a hard brush. This may damage the surfaces of the lights.
- Do not apply wax to the surfaces of the lights. Wax may cause damage to the lenses.

■ To prevent damage to the windshield wiper arms

When lifting the wiper arms away from the windshield, pull the driver side wiper arm upward first, and repeat for the passenger side. When returning the wipers to their original position, do so from the passenger side first.

■ When using an automatic car wash (vehicles with rain-sensing windshield wipers)

Set the wiper switch to the off position. If the wiper switch is in "AUTO", the wipers may operate and the wiper blades may be damaged.

■ When using a high pressure car wash

- Vehicles with rear view monitor system: When washing the vehicle, do not spray the camera or its surrounding area directly with a high pressure washer. Shock applied from high pressure water may cause the device to not operate normally.
- Do not spray water directly on the radar which is equipped behind the emblem. Otherwise it may cause the device to be damaged.

- Do not bring the nozzle tip close to boots (rubber or resin manufactured cover), connectors or the following parts. The parts may be damaged if they come into contact with high-pressure water.
 - Traction related parts
 - Steering parts
 - Suspension parts
 - Brake parts
- Keep the cleaning nozzle at least 30 cm (11.9 in.) away from the vehicle body. Otherwise resin section, such as moldings and bumpers, may be deformed and damaged. Also, do not continuously hold the nozzle in the same place.
- Do not spray the lower part of the windshield continuously. If water enters the air conditioning system intake located near the lower part of the windshield, the air conditioning system may not operate correctly.
- Do not wash the underside of the vehicle using a high pressure car washer.

Cleaning and protecting the vehicle interior

Perform cleaning in a manner appropriate to each component and its material.

Protecting the vehicle interior

- Remove dirt and dust using a vacuum cleaner. Wipe dirty surfaces with a cloth dampened with lukewarm water.
- If dirt cannot be removed, wipe it off with a soft cloth dampened with neutral detergent diluted to approximately 1%.
Wring out any excess water from the cloth and thoroughly wipe off remaining traces of detergent and water.

■ Shampooing the carpets

There are several commercial foaming-type cleaners available. Use a sponge or brush to apply the foam. Rub in overlapping circles. Do not use water. Wipe dirty surfaces and let them dry. Excellent results are obtained by keeping the carpet as dry as possible.

■ Handling the seat belts

Clean with mild soap and lukewarm water using a cloth or sponge. Also check the belts periodically for excessive wear, fraying or cuts.



WARNING

■ Water in the vehicle

- Do not splash or spill liquid in the vehicle, such as on the floor, in the hybrid battery (traction battery) air intake vent, and in the luggage compartment. (→P.315)
Doing so may cause the hybrid battery, electrical components, etc. to malfunction or catch fire.
- Do not get any of the SRS components or wiring in the vehicle interior wet. (→P.36)
An electrical malfunction may cause the airbags to deploy or not function properly, resulting in death or serious injury.
- Vehicles with wireless charger: Do not let the wireless charger (→P.303) get wet. Failure to do so may cause the charger to become hot and cause burns or could cause electric shock resulting in death or serious injury.

■ Cleaning the interior (especially instrument panel)

Do not use a polish wax or polish cleaner. The instrument panel may reflect off the windshield, obstructing the driver's view and leading to an accident, resulting in death or serious injury.



NOTICE

■ Cleaning detergents

- Do not use the following types of detergent, as they may discolor the vehicle interior or cause streaks or damage to painted surfaces:
 - Non-seat portions: Organic substances such as benzene or gasoline, alkaline or acidic solutions, dye, and bleach

**NOTICE**

- Seats: Alkaline or acidic solutions, such as thinner, benzene, and alcohol

- Do not use a polish wax or polish cleaner. The instrument panel's or other interior part's painted surface may be damaged.

■ Preventing damage to leather surfaces

Observe the following precautions to avoid damage to and deterioration of leather surfaces:

- Remove any dust or dirt from leather surfaces immediately.
- Do not expose the vehicle to direct sunlight for extended periods of time. Park the vehicle in the shade, especially during summer.
- Do not place items made of vinyl, plastic, or containing wax on the upholstery, as they may stick to the leather surface if the vehicle interior heats up significantly.

■ Water on the floor

Do not wash the vehicle floor with water.

Vehicle systems such as the audio system may be damaged if water comes into contact with electrical components such as the audio system above or under the floor of the vehicle. Water may also cause the body to rust.

■ When cleaning the inside of the windshield (vehicles with Toyota Safety Sense)

Do not allow glass cleaner to contact the lens. Also, do not touch the lens. (→P.204)

■ Cleaning the inside of the rear window

- Do not use glass cleaner to clean the rear window, as this may cause damage to the rear window defogger heater wires or antenna. Use a cloth dampened with lukewarm water to gently wipe the window clean. Wipe the window in strokes running parallel to the heater wires or antenna.
- Be careful not to scratch or damage the heater wires or antenna.

Cleaning the areas with satin-finish metal accents

- Remove dirt using a water-dampened soft cloth or synthetic chamois.
- Wipe the surface with a dry, soft cloth to remove any remaining moisture.

■ Cleaning the areas with satin-finish metal accents

The metal areas use a layer of real metal for the surface. It is necessary to clean them regularly. If dirty areas are left uncleaned for long periods of time, they may be difficult to clean.

Cleaning the leather areas

- Remove dirt and dust using a vacuum cleaner.
- Wipe off any excess dirt and dust with a soft cloth dampened with diluted detergent.

Use a diluted water solution of approximately 5% neutral wool detergent.

- Wring out any excess water from

the cloth and thoroughly wipe off all remaining traces of detergent.

- Wipe the surface with a dry, soft cloth to remove any remaining moisture. Allow the leather to dry in a shaded and ventilated area.

■ Caring for leather areas

Toyota recommends cleaning the interior of the vehicle at least twice a year to maintain the quality of the vehicle's interior.

Cleaning the synthetic leather areas

- Remove dirt and dust using a vacuum cleaner.
- Wipe it off with a soft cloth dampened with neutral detergent diluted to approximately 1%.
- Wring out any excess water from the cloth and thoroughly wipe off remaining traces of detergent and water.

Maintenance requirements

To ensure safe and economical driving, day-to-day care and regular maintenance are essential. Toyota recommends the maintenance below.

■ Where to go for maintenance service?

In order to maintain your vehicle in the best possible condition, Toyota recommends that maintenance service operations as well as other inspections and repairs be carried out by authorized Toyota retailers or Toyota authorized repairers, or any reliable repairers. For repairs and services covered by your warranty, please visit an authorized Toyota retailer or repairer, who will use genuine Toyota parts in repairing any difficulties you may encounter. There can also be advantages in utilizing authorized Toyota retailers or repairers for non-warranty repairs and services, as members of the Toyota network will be able to expertly assist you with any difficulties you may encounter.

Your Toyota retailer or Toyota authorized repairer, or any reliable repairer will perform all of the scheduled maintenance on your vehicle reliably and economically due to their experience with Toyota vehicles.



WARNING

■ If your vehicle is not properly maintained

Improper maintenance could result in serious damage to the vehicle and possible death or serious injury.

■ Handling of the 12-volt battery

12-volt battery posts, terminals and related accessories contain lead and lead compounds which are known to cause brain damage. Wash your hands after handling. (→P.330)

Scheduled maintenance

Scheduled maintenance should be performed at specified intervals according to the maintenance schedule.

For full details of your maintenance schedule, read the "Toyota Service Booklet" or "Toyota Warranty Booklet".

Do-it-yourself maintenance

What about do-it-yourself maintenance?

Many of the maintenance items are easy to do yourself if you have a little mechanical ability and a few basic automotive tools.

Note, however, that some maintenance tasks require special tools and skills. These are best performed by qualified technicians. Even if you're an experienced do-it-yourself mechanic, we recommend that repairs and maintenance be conducted by any authorized Toyota retailer or Toyota authorized repairer, or any reliable repairer. Any authorized Toyota retailer or repairer will keep a record of maintenance, which could be useful should you ever require Warranty Service. Should you choose to select a qualified and equipped professional other than an authorized Toyota repairer to service or maintain your vehicle, we recommend that you

request that a record of maintenance be kept.

■ Does your vehicle need repairs?

Be on the alert for changes in performance and sounds, and visual tip-offs that indicate service is needed. Some important clues are:

- Engine misses (misfire), stumbling or pinging
- Appreciable loss of power
- Strange engine noises
- A fluid leak under the vehicle (However, water dripping from the air conditioning system after use is normal.)
- Change in exhaust sound (This may indicate a dangerous carbon monoxide leak. Drive with the windows open and have the exhaust system checked immediately.)
- Flat-looking tires, excessive tire squeal when cornering, uneven tire wear
- Vehicle pulls to one side when driven straight on a level road
- Strange noises related to suspension movement
- Loss of brake effectiveness, spongy feeling brake pedal, pedal almost touches the floor, vehicle pulls to one side when braking
- Engine coolant temperature continually higher than normal (→P.94, 99)

If you notice any of these clues, take your vehicle to any authorized Toyota retailer or Toyota authorized repairer, or any reliable repairer as soon as possible. Your vehicle may need adjustment or repair.

Do-it-yourself service precautions

If you perform maintenance by yourself, be sure to follow the correct procedure as given in these sections.

Maintenance

Items	Parts and tools
12-volt battery condition (→P.330)	<ul style="list-style-type: none"> • Warm water • Baking soda • Grease • Conventional wrench (for terminal clamp bolts)
Engine/power control unit coolant level (→P.327)	<ul style="list-style-type: none"> • “Toyota Super Long Life Coolant” or a similar high quality ethylene glycol-based non-silicate, non-amine, non-nitrite and non-borate coolant with long-life hybrid organic acid technology. • “Toyota Super Long Life Coolant” is premixed with 50% coolant and 50% deionized water. • Funnel (used only for adding coolant)
Engine oil level (→P.325)	<ul style="list-style-type: none"> • “Toyota Genuine Motor Oil” or equivalent • Rag or paper towel • Funnel (used only for adding engine oil)

Items	Parts and tools
Fuses (→P.354)	<ul style="list-style-type: none"> • Fuse with same amperage rating as original
Hybrid battery (traction battery) air intake vent (→P.348)	<ul style="list-style-type: none"> • Vacuum cleaner, etc. • Flathead screwdriver
Light bulbs (→P.357)	<ul style="list-style-type: none"> • Bulb with same number and wattage rating as original • Flathead screwdriver • Wrench
Radiator and condenser (→P.329)	—
Tire inflation pressure (→P.342)	<ul style="list-style-type: none"> • Tire pressure gauge • Compressed air source
Washer fluid (→P.329)	<ul style="list-style-type: none"> • Water or washer fluid containing antifreeze (for winter use) • Funnel (used only for adding water or washer fluid)

 **WARNING**

The engine compartment contains many mechanisms and fluids that may move suddenly, become hot, or become electrically energized. To avoid death or serious injury, observe the following precautions.

When working on the engine compartment

- Make sure that the “ACCESSORY” or “IGNITION ON” on the multi-information display and the “READY” indicator are both off.

 **WARNING**

- Keep hands, clothing and tools away from the moving fan.
 - Be careful not to touch the engine, power control unit, radiator, exhaust manifold, etc. right after driving as they may be hot. Oil and other fluids may also be hot.
 - Do not leave anything that may burn easily, such as paper and rags, in the engine compartment.
 - Do not smoke, cause sparks or expose an open flame to fuel or 12-volt battery. Fuel and 12-volt battery fumes are flammable.
 - Be extremely cautious when working on the 12-volt battery. It contains poisonous and corrosive sulfuric acid.
 - Take care because brake fluid can harm your hands or eyes and damage painted surfaces. If fluid gets on your hands or in your eyes, flush the affected area with clean water immediately.
If you still experience discomfort, consult a doctor.
- **When working near the electric cooling fan or radiator grille**
Be sure the power switch is OFF. With the power switch in ON, the electric cooling fan may automatically start to run if the air conditioning is on and/or the coolant temperature is high. (→P.329)
- **Safety glasses**
Wear safety glasses to prevent flying or falling material, fluid spray, etc. from getting in your eyes.

 **NOTICE**■ **If you remove the air cleaner filter**

Driving with the air cleaner filter removed may cause excessive engine wear due to dirt in the air.

■ **If the fluid level is low or high**

It is normal for the brake fluid level to go down slightly as the brake pads wear or when the fluid level in the accumulator is high.

If the reservoir needs frequent refilling, it may indicate a serious problem.

Hood

Opening the hood

- 1 Pull the hood lock release lever.
The hood will pop up slightly.

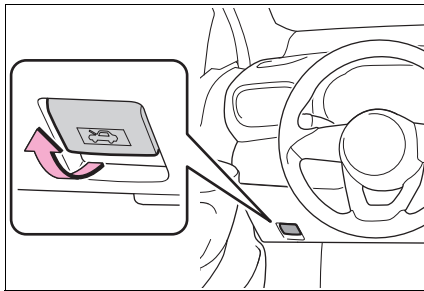

- 2 Push the auxiliary catch lever to the left and lift the hood.

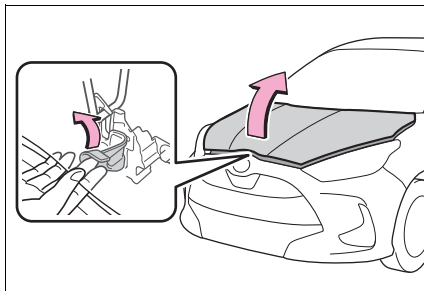

- 3 Hold the hood open by inserting the support rod into the slot.

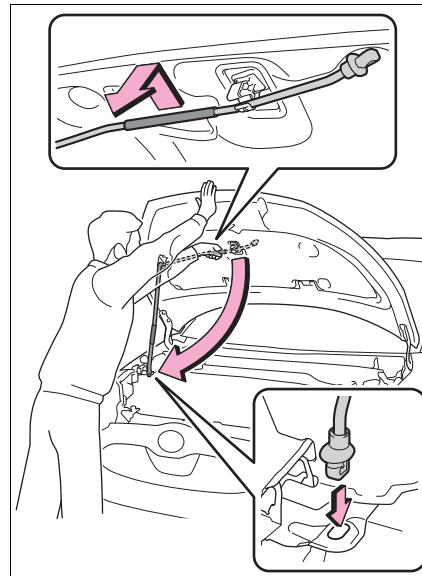

⚠ WARNING

■ Pre-driving check

Check that the hood is fully closed and locked.
If the hood is not locked properly, it may open while the vehicle is in motion and cause an accident, which may result in death or serious injury.

■ To prevent a injuries

The support rod may be hot after driving the vehicle. Touching the hot support rod may lead to burns or other serious injuries.

■ After installing the support rod into the slot

Make sure the rod supports the hood securely preventing it from falling down onto your head or body.

**NOTICE****■ When closing the hood**

Be sure to return the support rod to its clip before closing the hood. Closing the hood with the support rod not clipped could cause the hood to bend.

Positioning a floor jack

When using a floor jack, follow the instructions in the manual provided with the jack and perform the operation safely.

When raising your vehicle with a floor jack, position the jack correctly. Improper placement may damage your vehicle or cause injury.

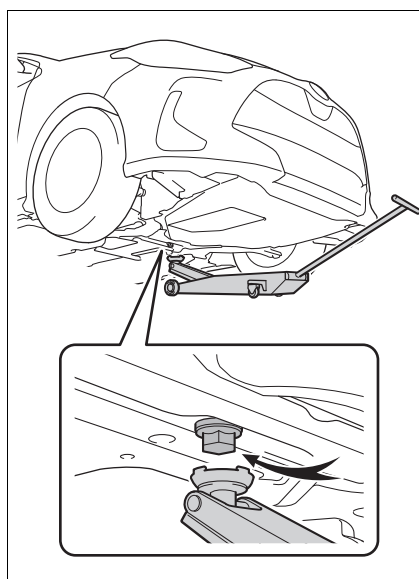
Location of the jack point**■ Front**

6

Maintenance and care

■ Rear

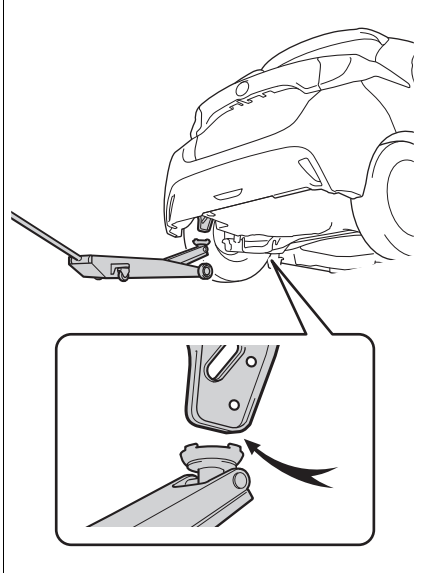

 NOTICE

■ **When raising your vehicle**

Do not jack the vehicle at the suspension. The suspension may be damaged.

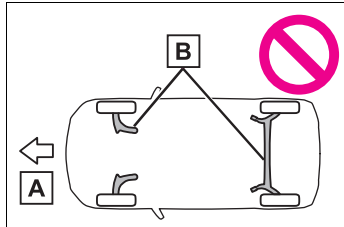

A Front

B Suspension

Engine compartment

Components

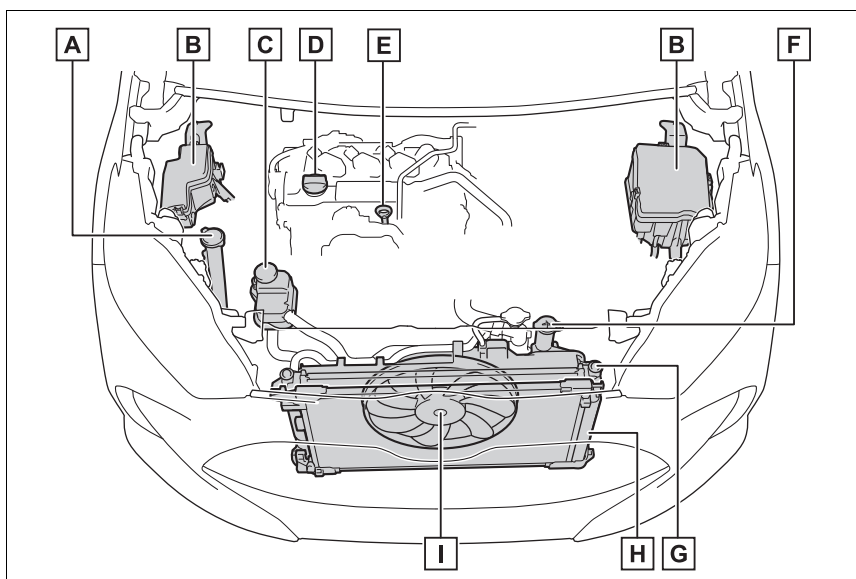

- A** Washer fluid tank (→P.329)
- B** Fuse boxes (→P.354)
- C** Power control unit coolant reservoir (→P.327)
- D** Engine oil filler cap (→P.326)
- E** Engine oil level dipstick (→P.326)
- F** Engine coolant reservoir (→P.327)
- G** Radiator (→P.329)
- H** Condenser (→P.329)
- I** Electric cooling fan

■ **12-volt battery**
→P.330

Checking and adding the engine oil

With the engine at operating tem-

perature and turned off, check the oil level on the dipstick.

■ **Checking the engine oil**

- 1 Park the vehicle on level ground. After warming up the engine and turning off the hybrid system, wait more than 5 minutes for the oil to drain back into the bottom of the engine.
- 2 Holding a rag under the end, pull the dipstick out.

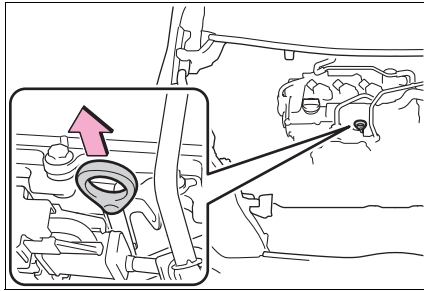

- 3 Wipe the dipstick clean.
- 4 Reinsert the dipstick fully.
- 5 Holding a rag under the end, pull the dipstick out and check the oil level.

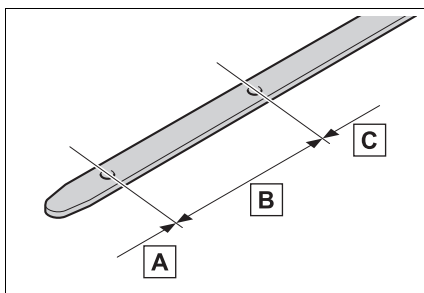

- A** Low
- B** Normal
- C** Excessive

The shape of the dipstick may differ depending on the type of vehicle or engine.

- 6 Wipe the dipstick and reinsert it fully.

■ **Checking the oil type and preparing the item needed**

Make sure to check the oil type and prepare the items needed before adding oil.

- Engine oil selection
→P.423
- Oil quantity (Low → Full)
1.5 L (1.6 qt., 1.3 Imp. qt.)
- Item
Clean funnel

■ **Adding engine oil**

If the oil level is below or near the low level mark, add engine oil of the same type as that already in the engine.

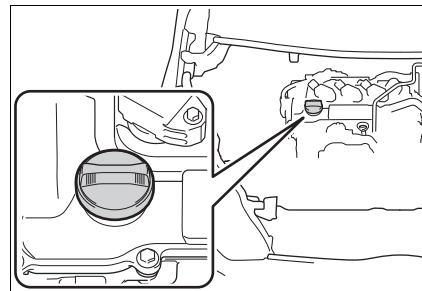

- 1 Remove the oil filler cap by turning it counterclockwise.
- 2 Add engine oil slowly, checking the dipstick.
- 3 Install the oil filler cap by turning it clockwise.













■ Engine oil consumption

A certain amount of engine oil will be consumed while driving. In the following situations, oil consumption may increase, and engine oil may need to be refilled in between oil maintenance intervals.

- When the engine is new, for example directly after purchasing the vehicle or after replacing the engine
- If low quality oil or oil of an inappropriate viscosity is used
- When driving at high engine speeds or with a heavy load, when towing (vehicles with towing packages), or when driving while accelerating or decelerating frequently
- When leaving the engine idling for a long time, or when driving frequently through heavy traffic

■ After changing the engine oil

The engine oil maintenance data should be reset. Perform the following procedures:

- 1 Press  /  (vertical display) or  /  (horizontal display) of the meter control switch to select .
- 2 Press  /  (vertical display) or  /  (horizontal display) to select "Vehicle Settings" and then press and hold OK.
- 3 Press  /  to select "Oil Maintenance" and then press OK.
- 4 Press  /  to select "Yes" and then press OK.

A message will be displayed on the multi-information display when the reset procedure has been completed.

WARNING

■ Used engine oil

- Used engine oil contains potentially harmful contaminants which may cause skin disorders such as inflammation and skin cancer, so care should be taken to avoid prolonged and repeated contact. To remove used engine oil from your skin, wash thoroughly with soap and water.
- Dispose of used oil and filters only in a safe and acceptable manner. Do not dispose of used oil and filters in household trash, in sewers or onto the ground. Call any authorized Toyota retailer or Toyota authorized repairer, or any reliable repairer, service station or auto parts store for information concerning recycling or disposal.
- Do not leave used engine oil within the reach of children.

NOTICE

■ To prevent serious engine damage

Check the oil level on a regular basis.

■ When replacing the engine oil

- Be careful not to spill engine oil on the vehicle components.
- Avoid overfilling, or the engine could be damaged.
- Check the oil level on the dipstick every time you refill the vehicle.
- Be sure the engine oil filler cap is properly tightened.

Checking the coolant

■ Engine coolant reservoir

The coolant level is satisfactory if it is between the "F" and "L" lines on

the reservoir when the engine is cold.

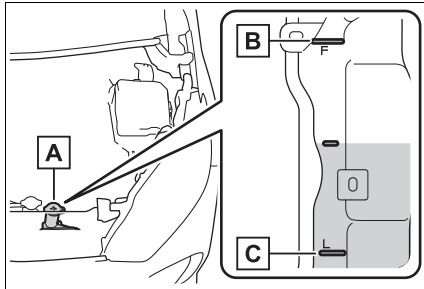

A Reservoir cap

B “F” line

C “L” line

If the level is on or below the “L” line, add coolant up to the “F” line. (→P.414)

Power control unit coolant reservoir

The coolant level is satisfactory if it is between the “F” and “L” lines on the reservoir when the hybrid system is cold.

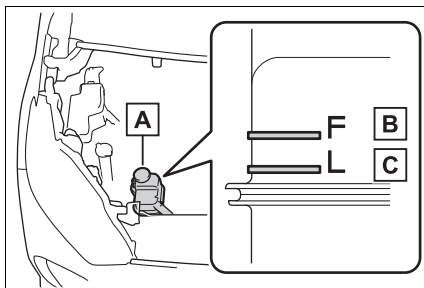

A Reservoir cap

B “F” line

C “L” line

If the level is on or below the “L” line, add coolant up to the “F” line. (→P.414)

Coolant selection

Only use “Toyota Super Long Life Coolant” or a similar high quality ethylene glycol based non-silicate, non-amine, non-nitrite, and non-borate coolant with long-life hybrid organic acid technology.

“Toyota Super Long Life Coolant” is a mixture of 50% coolant and 50% deionized water. (Minimum temperature: -35°C [-31°F])

For more details about coolant, contact any authorized Toyota retailer or Toyota authorized repairer, or any reliable repairer.

If the coolant level drops within a short time of replenishing

Visually check the radiator, hoses, engine/power control unit coolant reservoir caps, drain cock and water pump. If you cannot find a leak, have any authorized Toyota retailer or Toyota authorized repairer, or any reliable repairer, test the cap and check for leaks in the cooling system.

WARNING

When the hybrid system is hot

Do not remove the engine/power control unit coolant reservoir caps.

The cooling system may be under pressure and may spray hot coolant if the cap is removed, causing serious injuries, such as burns.

NOTICE

When adding coolant

Coolant is neither plain water nor straight antifreeze. The correct mixture of water and antifreeze must be used to provide proper lubrication, corrosion protection and cooling. Be sure to read the antifreeze or coolant label.

 NOTICE

■ **If you spill coolant**

Be sure to wash it off with water to prevent it from damaging parts or paint.

Checking the radiator and condenser

Check the radiator and condenser and clear away any foreign objects. If either of the above parts is extremely dirty or you are not sure of their condition, have your vehicle inspected by any authorized Toyota retailer or Toyota authorized repairer, or any reliable repairer.

 WARNING

■ **When the hybrid system is hot**

Do not touch the radiator or condenser as they may be hot and cause serious injuries, such as burns.

Adding the washer fluid

If the washer fluid level is at “1/2”, add washer fluid.

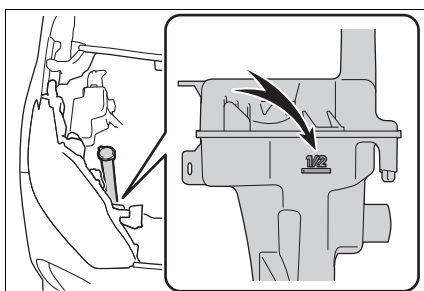

 WARNING

■ **When adding washer fluid**

Do not add washer fluid when the hybrid system is hot or operating as washer fluid contains alcohol and may catch fire if spilled on the engine, etc.

 NOTICE

■ **Do not use any fluid other than washer fluid**

Do not use soapy water or engine antifreeze instead of washer fluid. Doing so may cause streaking on the vehicle's painted surfaces, as well as damaging the pump leading to problems of the washer fluid not spraying.

■ **Diluting washer fluid**

Dilute washer fluid with water as necessary. Refer to the freezing temperatures listed on the label of the washer fluid bottle.

12-volt battery

Location

The 12-volt battery is located in the right-hand side of the rear seats.

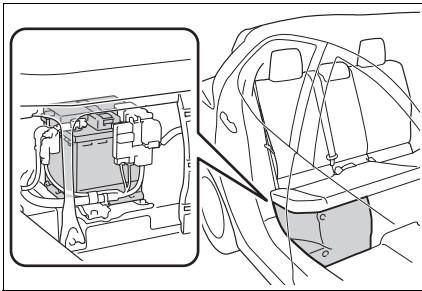

Removing the 12-volt battery cover

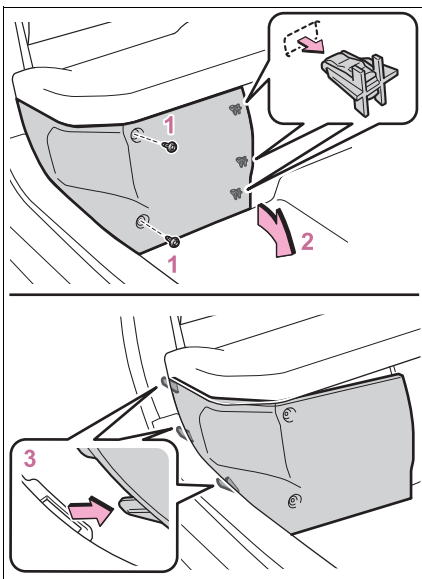

- 1** Remove the screws.
- 2** Remove the clips from the claws.
- 3** Slide the tabs out of the

notches.

Before recharging

When recharging, the 12-volt battery produces hydrogen gas which is flammable and explosive. Therefore, observe the following precautions before recharging:

- If recharging with the 12-volt battery installed on the vehicle, be sure to disconnect the ground cable.
- Make sure the power switch on the charger is off when connecting and disconnecting the charger cables to the 12-volt battery.

After recharging/reconnecting the 12-volt battery (vehicles with a smart entry & start system)

- Unlocking the doors using the smart entry & start system may not be possible immediately after reconnecting the 12-volt battery. If this happens, use the wireless remote control or the mechanical key to lock/unlock the doors.
- Start the hybrid system with the power switch in ACC. The hybrid system may not start with the power switch turned off. However, the hybrid system will operate normally from the second attempt.
- The power switch mode is recorded by the vehicle. If the 12-volt battery is reconnected, the vehicle will return the power switch mode to the status it was in before the 12-volt battery was disconnected. Make sure to turn off the power before disconnecting the 12-volt battery. Take extra care when connecting the 12-volt battery if the power switch mode prior to discharge is unknown.

If the system will not start even after multiple attempts, contact any authorized Toyota retailer or Toyota authorized repairer, or any reliable repairer.

**WARNING****Chemicals in the 12-volt battery**

The 12-volt battery contains poisonous and corrosive sulfuric acid and may produce hydrogen gas which is flammable and explosive. To reduce the risk of death or serious injury, take the following precautions while working on or near the 12-volt battery:

- Do not cause sparks by touching the 12-volt battery terminals with tools.
- Do not smoke or light a match near the 12-volt battery.
- Avoid contact with eyes, skin and clothes.
- Never inhale or swallow electrolyte.
- Wear protective safety glasses when working near the 12-volt battery.
- Keep children away from the 12-volt battery.

Where to safely charge the 12-volt battery

Always charge the 12-volt battery in an open area. Do not charge the 12-volt battery in a garage or closed room where there is insufficient ventilation.

Emergency measures regarding electrolyte

- If electrolyte gets in your eyes
Flush your eyes with clean water for at least 15 minutes and get immediate medical attention. If possible, continue to apply water with a sponge or cloth while traveling to the nearest medical facility.
- If electrolyte gets on your skin
Wash the affected area thoroughly. If you feel pain or burning, get medical attention immediately.

- If electrolyte gets on your clothes
It can soak through clothing on to your skin. Immediately take off the clothing and follow the procedure above if necessary.

- If you accidentally swallow electrolyte
Drink a large quantity of water or milk. Get emergency medical attention immediately.

When replacing the 12-volt battery

Use a 12-volt battery designed for this vehicle. Failure to do so may cause gas (hydrogen) to enter the passenger compartment, causing a fire or explosion.

For replacement of the 12-volt battery, contact any authorized Toyota retailer or Toyota authorized repairer, or any reliable repairer.

**NOTICE****When recharging the 12-volt battery**

Never recharge the 12-volt battery while the hybrid system is operating. Also, be sure all accessories are turned off.

Exterior

Make sure that the 12-volt battery terminals are not corroded and that there are no loose connections, cracks, or loose clamps.

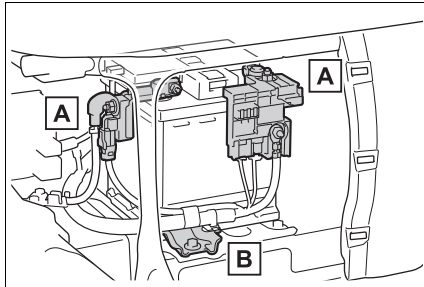

- A** Terminals
- B** Hold-down clamp

Tires

Replace or rotate tires in accordance with maintenance schedules and treadwear.

Checking tires

Check if the treadwear indicators are showing on the tires. Also check the tires for uneven wear, such as excessive wear on one side of the tread.

Check the spare tire condition and pressure if not rotated.

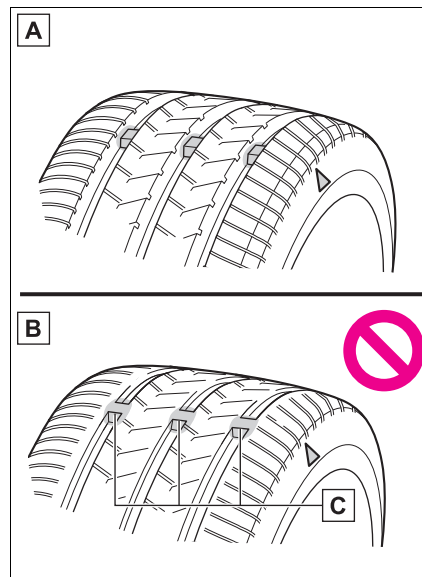

- A** New tread
- B** Worn tread
- C** Treadwear indicator

The location of treadwear indicators is shown by a "TWI" or "△" mark, etc.,

molded into the sidewall of each tire. Replace the tires if the treadwear indicators are showing on a tire.

■ When to replace your vehicle's tires

Tires should be replaced if:

- The treadwear indicators are showing on a tire.
- You have tire damage such as cuts, splits, cracks deep enough to expose the fabric, and bulges indicating internal damage
- A tire goes flat repeatedly or cannot be properly repaired due to the size or location of a cut or other damage

If you are not sure, consult with any authorized Toyota retailer or Toyota authorized repairer, or any reliable repairer.

■ Tire life

Any tire over 6 years old must be checked by a qualified technician even if it has seldom or never been used, or damage is not obvious.

■ Low profile tires (16 and 17-inch tires)

Generally, low profile tires will wear more rapidly and tire grip performance will be reduced on snowy and/or icy roads when compared to standard tires. Be sure to use snow tires on snowy and/or icy roads and drive carefully at a speed appropriate for road and weather conditions.

■ If the tread on snow tires wears down below 4 mm (0.16 in.)

The effectiveness of the tires as snow tires is lost.

■ Checking the tire valves

When replacing the tires, check the tire valves for deformation, cracks, and other damage.

WARNING

■ When inspecting or replacing tires

Observe the following precautions to prevent accidents. Failure to do so may cause damage to parts of the drivetrain as well as dangerous handling characteristics, which may lead to an accident resulting in death or serious injury.

- Do not mix tires of different makes, models or tread patterns. Also, do not mix tires of remarkably different treadwear.
- Do not use tire sizes other than those recommended by Toyota.
- Do not mix differently constructed tires (radial, bias-belted or bias-ply tires).
- Do not mix summer, all season and snow tires.
- Do not use tires that have been used on another vehicle. Do not use tires if you do not know how they were used previously.

NOTICE

■ Low profile tires (16 and 17-inch tires)

Low profile tires may cause greater damage than usual to the tire wheel when sustaining impact from the road surface. Therefore, pay attention to the following:

- Be sure to use proper tire inflation pressure. If tires are under-inflated, they may be damaged more severely.
- Avoid potholes, uneven pavement, curbs and other road hazards. Failure to do so may lead to severe tire and wheel damage.



NOTICE

■ **If tire inflation pressure of each tire becomes low while driving**

Do not continue driving, or your tires and/or wheels may be ruined.

■ **Driving on rough roads**

Take particular care when driving on roads with loose surfaces or potholes. These conditions may cause losses in tire inflation pressure, reducing the cushioning ability of the tires. In addition, driving on rough roads may cause damage to the tires themselves, as well as the vehicle's wheels and body.

Tire rotation

Rotate the tires in the order shown.

- ▶ Vehicles without a full-size spare tire

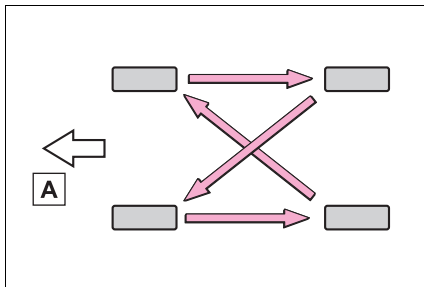

A Front

- ▶ Vehicles with a full-size spare tire

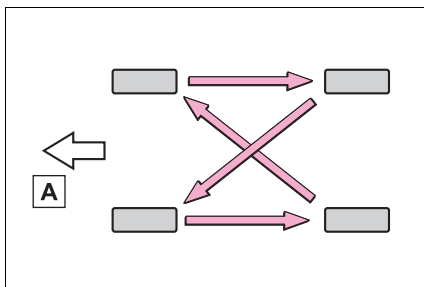

A Front

To equalize tire wear and help extend tire life, Toyota recommends that tire rotation is carried out approximately every 10000 km (6000 miles).

When rotating front and rear tires which have different tire inflation pressures, do not fail to initialize the tire pressure warning system after tire rotation.

Tire pressure warning system

Your vehicle is equipped with a tire pressure warning system that uses tire pressure warning valves and transmitters to detect low tire inflation pressure before serious problems arise.

The tire pressure warning system of this vehicle adopts a 2-type warning system.

- When “Adjust Pressure” is displayed (Normal Warning)

A warning with the tire pressure warning light and warning buzzer when there is an unknown level of low tire pressure with the appearance of the tire due to natural air leakage as well as the pressure lowering due to changes in the pressure according to the outside temperature. (Ways of coping: →P.381, 427)

- When “Immediately Check tire when Safe” is displayed (Emergency Warning)

A warning with the tire pressure warning light and warning buzzer when there is a known level of low tire pres-

sure with the appearance of the tire due to pressure suddenly lowering. (Ways of coping: →P.386, 397)

However, the system may not be able to detect sudden tire ruptures (bursting, etc.).

The tire pressure detected by the tire pressure warning system can be displayed on the 9-inch display multimedia system or multi-information display.

► 9-inch display multimedia system

- 1 Press the "HOME" button
- 2 Select "Vehicle" on the "Home" screen
- 3 If a screen other than "Tyre pressure" is displayed, select "Tyre pressure"

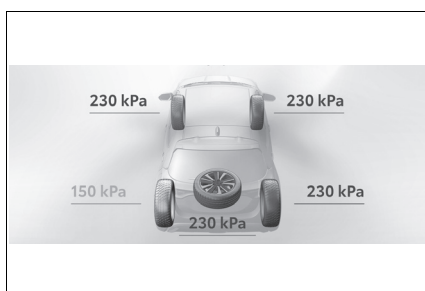

► Multi-information display

The unit can be changed.

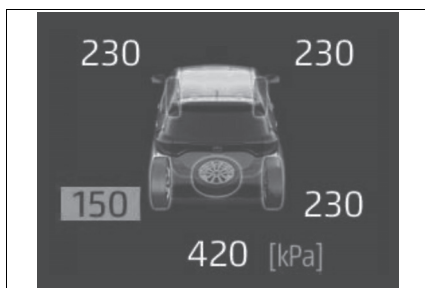

■ How to change the unit

- 1 Park the vehicle in a safe place and turn the power switch off.

Changing the unit cannot be performed while the vehicle is moving.

- 2 Turn the power switch to ON.
- 3 Press < / > (vertical display) or ^ / v (horizontal display) of the meter control switch to select .
- 4 Press ^ / v (vertical display) or < / > (horizontal display) to select "Vehicle Settings" and then press and hold OK .
- 5 Press ^ / v to select "TPWS setting" and then press OK .
- 6 Press ^ / v to select "Setting Unit".
- 7 Press ^ / v to select the desired unit and then press OK .

■ Routine tire inflation pressure checks

The tire pressure warning system does not replace routine tire inflation pressure checks. Make sure to check tire inflation pressure as part of your routine of daily vehicle checks.

■ Tire inflation pressure

- It may take a few minutes to display the tire inflation pressure after the power switch is turned to ON. It may

also take a few minutes to display the tire inflation pressure after inflation pressure has been adjusted.

- Tire inflation pressure changes with temperature. The displayed values may also be different from the values measured using a tire pressure gauge.
- **Situations in which the tire pressure warning system may not operate properly**
 - In the following cases, the tire pressure warning system may not operate properly.
 - If non-genuine Toyota wheels are used.
 - A tire has been replaced with a tire that is not an OE (Original Equipment) tire.
 - A tire has been replaced with a tire that is not of the specified size.
 - Tire chains, etc. are equipped.
 - An auxiliary-supported run-flat tire is equipped.
 - If a window tint that affects the radio wave signals is installed.
 - If there is a lot of snow or ice on the vehicle, particularly around the wheels or wheel housings.
 - If the tire inflation pressure is extremely higher than the specified level.
 - If tires not equipped with tire pressure warning valves and transmitters are used.
 - If the ID code on the tire pressure warning valves and transmitters is not registered in the tire pressure warning computer.
 - Performance may be affected in the following situations.
 - Near a TV tower, electric power plant, gas station, radio station, large display, airport or other facility that generates strong radio waves or electrical noise.
 - When carrying a portable radio, cellular phone, cordless phone or other wireless communication device.
 - When the vehicle is parked, the time taken for the warning to start or go off

could be extended.

- When tire inflation pressure declines rapidly for example when a tire has burst, the warning may not function.

■ Warning performance of the tire pressure warning system

The warning of the tire pressure warning system will change in accordance with driving conditions. For this reason, the system may give a warning even if the tire pressure does not reach a low enough level, or if the pressure is higher than the pressure that was adjusted to when the system was initialized.

Installing tire pressure warning valves and transmitters

When replacing tires or wheels, tire pressure warning valves and transmitters must also be installed.

When new tire pressure warning valves and transmitters are installed, new ID codes must be registered in the tire pressure warning computer and the tire pressure warning system must be initialized. Have tire pressure warning valves and transmitter ID codes registered any authorized Toyota retailer or Toyota authorized repairer, or any reliable repairer. (→P.339)

■ Replacing tires and wheels

If the ID code of the tire pressure warning valve and transmitter is not registered, the tire pressure warning system will not work properly. After driving for about 10 minutes, the tire pressure warning light blinks for 1 minute and stays on to indicate a system malfunction.



NOTICE

■ Repairing or replacing tires, wheels, tire pressure warning valves, transmitters and tire valve caps

- When removing or fitting the wheels, tires or the tire pressure warning valves and transmitters, contact any authorized Toyota retailer or Toyota authorized repairer, or any reliable repairer as the tire pressure warning valves and transmitters may be damaged if not handled correctly.

- Make sure to install the tire valve caps. If the tire valve caps are not installed, water could enter the tire pressure warning valves and the tire pressure warning valves could be bound.

- When replacing tire valve caps, do not use tire valve caps other than those specified. The cap may become stuck.

■ To avoid damage to the tire pressure warning valves and transmitters

When a tire is repaired with liquid sealants, the tire pressure warning valve and transmitter may not operate properly. If a liquid sealant is used, contact any authorized Toyota retailer or Toyota authorized repairer, or any reliable repairer as soon as possible. Make sure to replace the tire pressure warning valve and transmitter when replacing the tire. (→P.336)

Initializing the tire pressure warning system

- **The tire pressure warning system must be initialized in the following circumstances:**

- When rotating front and rear tires which have different tire inflation

pressures.

- When changing the tire size.
- When the tire inflation pressure is changed such as when changing traveling speed or load weight.
- When changing between two registered wheel sets.

When the tire pressure warning system is initialized, the current tire inflation pressure is set as the benchmark pressure.





■ How to initialize the tire pressure warning system

- 1 Park the vehicle in a safe place and turn the power switch off, wait for approximately 15 minutes or more, and then perform the procedure.
- 2 Adjust the tire inflation pressure to the specified cold tire inflation pressure level. (→P.427)

Make sure to adjust the tire pressure to the specified cold tire inflation pressure level. The tire pressure warning system will operate based on this pressure level.

- 3 Turn the power switch to ON.

Initialization cannot be performed while the vehicle is moving.

- 4 Press  /  (vertical display) or  /  (horizontal display) of the meter control switch to select .

- 5 Press \wedge / \vee (vertical display) or \langle / \rangle (horizontal display) to select "Vehicle Settings" and then press and hold OK .
- 6 Press \wedge / \vee to select "TPWS setting" and then press OK .
- 7 Press \wedge / \vee to select "Setting Pressure". Then press and hold OK until the tire pressure warning light blinks 3 times.

Then a message will be displayed on the multi-information display. "--" will be displayed on the multi-information display for the inflation pressure of each tire while initialization is being performed.

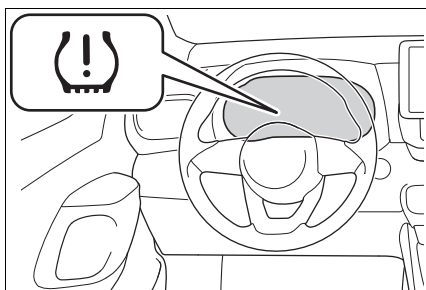

- 8 Drive straight (with occasional left and right turns) at approximately 40 km/h (25 mph) or more for approximately 10 to 30 minutes.

Even if the vehicle is not driven at approximately 40 km/h (25 mph) or more, initialization can be completed by driving for a long time. However, if initialization does not complete after driving for 1 hour or more, park the vehicle in a safe place for more than 15 min-

utes and please drive a vehicle once again with the power switch ON. (→P.340)

■ Initialization procedure

- Make sure to carry out initialization after adjusting the tire inflation pressure. Also, make sure the tires are cold before carrying out initialization or tire inflation pressure adjustment.
- If you have accidentally turned the power switch off during initialization, it is not necessary to press the reset switch again as initialization will restart automatically when the power switch is turned to ON the next time.
- If you accidentally press the reset switch when initialization is not necessary, adjust the tire inflation pressure to the specified level when the tires are cold, and conduct initialization again.
- While the position of each tire is being determined and the inflation pressures are not being displayed on the multi-information display, if the inflation pressure of a tire drops, the tire pressure warning light will come on.

■ If the tire pressure warning system is not initialized properly

- In the following situations, initialization may take longer than usual to be completed or may not be possible. (Usually, the vehicle will need to be driven for approximately 10 to 30 minutes to complete initialization.) If initialization is not complete after driving approximately 30 minutes, continue driving for a while.
 - If the vehicle is driven on an unpaved road, it may take longer to complete initialization.
 - If the vehicle is backed up while performing initialization, data collected during initialization will be cleared and it will take longer than normal to complete.
 - If the vehicle is driven in heavy traffic or another situation where other vehi-

cles are driven close by, it may take time for the system to recognize the tire pressure warning valve and transmitters of your vehicle over those of other vehicles.

If initialization is not complete after driving for approximately 1 hour, park the vehicle in a safe place for approximately 20 minutes and then drive the vehicle again.

- In the following situations, initialization will not be started or was not completed properly and the system will not operate properly. Perform the initialization procedure again.
 - If, when attempting to start initialization, the tire pressure warning light does not blink 3 times.
 - If, when the vehicle has been driven for about 20 minutes after performing initialization, the tire pressure warning light blinks for approximately 1 minute and then illuminates.
- If initialization cannot be completed after performing the above procedure, contact any authorized Toyota retailer or Toyota authorized repairer, or any reliable repairer.



WARNING

■ When initializing the tire pressure warning system

Do not initialize the tire pressure warning system without first adjusting the tire inflation pressure to the specified level. Otherwise, the tire pressure warning light may not come on even if the tire inflation pressure is low, or it may come on when the tire inflation pressure is actually normal.













Registering ID codes

The tire pressure warning valve and transmitter is equipped with a unique ID code. When replacing a tire pressure warning valve and

transmitter, it is necessary to register the ID code.

The ID codes can be registered on  of the multi-information display.

Park the vehicle in a safe place, wait for approximately 15 minutes or more and perform the procedure.

- 1 Press  /  (vertical display) or  /  (horizontal display) of the meter control switch to select .
- 2 Press  /  (vertical display) or  /  (horizontal display) to select "Vehicle Settings" and then press OK .
- 3 Press  /  to select "TPWS setting" and then press OK .
- 4 Press  /  to select "Identifying Each Wheel & Position". Then press and hold OK until the tire pressure warning light blinks slowly 3 times.

Then a message will be displayed on the multi-information display.

When registration is being performed, the tire pressure warning light will blink for approximately 1 minute then illuminate and "--" will be displayed for the inflation pressure of each tire on the

multi-information display.

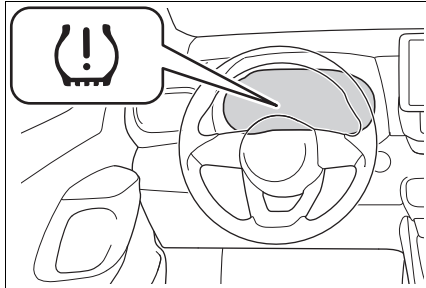

- 5 Drive straight (with occasional left and right turns) at approximately 40 km/h (25 mph) or more for approximately 10 to 30 minutes.

Registration is complete when the tire pressure warning light turns off and the inflation pressure of each tire is displayed on the multi-information display.

Registration may take longer than approximately 1 hour in certain situations, such as when the vehicle is stopped for a long time at traffic lights, etc. (→P.340)

After registering the ID codes, make sure to initialize the tire pressure warning system. (→P.337)

■ **When registering ID codes**

- Before performing ID code registration, make sure that no wheels with tire pressure warning valve and transmitters installed are near the vehicle.
- Make sure to initialize the tire pressure warning system after registering the ID codes. If the system is initialized before registering the ID codes, the initialized values will be invalid.
- As the tires will be warm when registration is completed, make sure to allow the tires to cool before performing initialization.

■ **Canceling ID code registration**

- To cancel ID code registration after it has been started, operate the multi-

information display to select “Identifying Each Wheel & Position”. (→P.339)

- If ID code registration has been canceled, the tire pressure warning light will blink for approximately 1 minute when the power switch is turned to ON mode and then illuminate. The tire pressure warning system will be operational when the tire pressure warning light turns off.
- If the warning light does not turn off even after several minutes have elapsed, ID code registration may not have been canceled correctly. To cancel registration, perform the ID code registration start procedure again and then turn the power switch off before driving.

■ **If ID codes are not registered properly**

- In the following situations, ID code registration may take longer than usual to be completed or may not be possible. (Usually, the vehicle will need to be driven for approximately 10 to 30 minutes to complete ID code registration.)
If ID code registration is not complete after driving for approximately 30 minutes, continue driving for a while.
- If the vehicle is driven on an unpaved road, it may take longer than normal to complete registration.
- If the vehicle is backed up while performing registration, data collected during registration will be cleared, and it will take longer than normal to complete.
- If the vehicle is driven in heavy traffic or another situation where other vehicles are driven close by, it may take time for the system to recognize the tire pressure warning valve and transmitters of your vehicle over those of other vehicles.
- If a wheel with a tire pressure warning valve and transmitter installed is inside or near the vehicle, registration of the ID codes for the installed wheels may not be possible.

If ID registration is not complete after

driving for approximately 1 hour, park the vehicle in a safe place for approximately 20 minutes and then perform the ID code registration procedure again.

- In the following situations, ID code registration will not be started or was not completed properly and the system will not operate properly. Perform the ID code registration procedure again.
 - If, when attempting to start ID code registration, the tire pressure warning light does not blink slowly 3 times.
 - If, when the vehicle has been driven for about 10 minutes after performing ID code registration, the tire pressure warning light blinks for approximately 1 minute and then illuminates.
- If ID code registration cannot be completed after performing the above procedure, contact any authorized Toyota retailer or Toyota authorized repairer, or any reliable repairer.

Selecting wheel set

Your vehicle is equipped with tire pressure warning system with the function to have ID codes registered for a second wheel set, for example a winter set, by any authorized Toyota retailer or Toyota authorized repairer, or any reliable repairer.

After registration of a second wheel set, either of these two wheel sets can be selected for usage with the tire pressure warning system.

■ Operating conditions for the function

- This function will perform the change of wheel set only if a second wheel set has been regis-

tered. If no second wheel set has been registered, no change will be made when selecting this function in the menu.

- Only a change between both registered wheel set is possible, mixing between these wheel sets is not supported.

■ How to change between wheel sets

- 1 Have the vehicle fitted with the preferred wheel set.
- 2 Press \langle / \rangle (vertical display) or \wedge / \vee (horizontal display) of the meter control switch to select .
- 3 Press \wedge / \vee (vertical display) or \langle / \rangle (horizontal display) to select "Vehicle Settings" and then press OK .
- 4 Press \wedge / \vee to select "TPWS setting" and then press OK .
- 5 Press \wedge / \vee to select "Identifying Each Wheel & Position". Then press and hold OK until the tire pressure warning light blinks slowly 3 times. Afterward,

turns on after flashing for 1 minute.

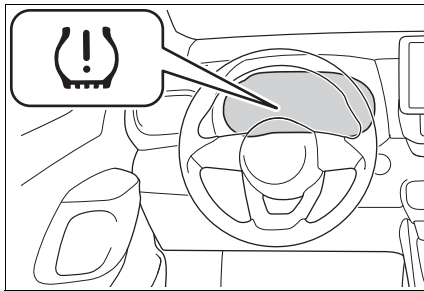

After 2 minutes, registration of a second wheel set is being performed. The tire pressure warning light will turn off and "--" will be displayed for the inflation pressure of each tire on the multi-information display.

6 Initialize the tire pressure warning system. (→P.337)

If the tire inflation pressure settings for the installed tire changes, initialization operations are required, but if the same tire inflation pressure, initialization is not required.

7 Drive straight (with occasional left and right turns) at approximately 40 km/h (25 mph) or more for approximately 10 to 30 minutes.

Registration of a second wheel set is complete when the tire pressure warning light turns off and the inflation pressure of each tire is displayed on the multi-information display.

■ **Certifications for the tire pressure warning system**

→P.552

Tire inflation pressure

Make sure to maintain proper tire inflation pressure. Tire inflation pressure should be checked at least once per month. However, Toyota recommends that tire inflation pressure be checked once every two weeks. (→P.427)

Tire-loading information label

Tire inflation pressure is specified on the label on the driver's side door frame as shown.

▶ **Left-hand drive vehicles**

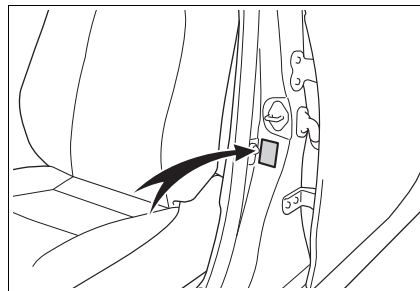

▶ **Right-hand drive vehicles**

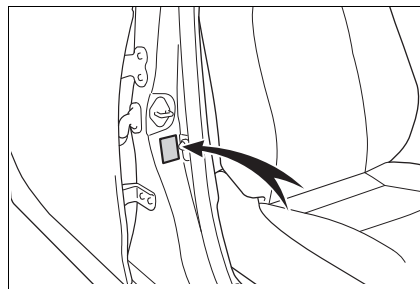

■ Effects of incorrect tire inflation pressure

Driving with incorrect tire inflation pressure may result in the following:

- Reduced safety
- Damage to the drivetrain
- Reduced tire life due to wear
- Reduced fuel economy
- Reduced driving comfort and poor handling

If a tire needs frequent inflating, have it checked by any authorized Toyota retailer or Toyota authorized repairer, or any reliable repairer.

■ Instructions for checking tire inflation pressure

When checking tire inflation pressure, observe the following:

- Check only when the tires are cold.
If your vehicle has been parked for at least 3 hours or has not been driven for more than 1.5 km or 1 mile, you will get an accurate cold tire inflation pressure reading.
- Always use a tire pressure gauge.
It is difficult to judge if a tire is properly inflated based only on its appearance.
- It is normal for the tire inflation pressure to be higher after driving as heat is generated in the tire. Do not reduce tire inflation pressure after driving.
- Passengers and luggage weight should be placed so that the vehicle is balanced.



WARNING

■ Proper inflation is critical to save tire performance

Keep your tires properly inflated. If the tires are not properly inflated, the following conditions may occur which could lead to an accident resulting in death or serious injury:

- Excessive wear

- Uneven wear
- Poor handling
- Possibility of blowouts resulting from overheated tires
- Air leaking from between tire and wheel
- Wheel deformation and/or tire damage
- Greater possibility of tire damage while driving (due to road hazards, expansion joints, sharp edges on the road, etc.)



NOTICE

■ When inspecting and adjusting tire inflation pressure

Be sure to put the tire valve caps back on.

If a valve cap is not installed, dirt or moisture may get into the valve and cause an air leak, resulting in decreased tire inflation pressure.

Wheels

If a wheel is bent, cracked or heavily corroded, it should be replaced. Otherwise, the tire may separate from the wheel or cause a loss of handling control.

Wheel selection

When replacing wheels, care should be taken to ensure that they are equivalent to those removed in load capacity, diameter, rim width and inset*.

Replacement wheels are available at any authorized Toyota retailer or Toyota authorized repairer, or any reliable repairer.

*: Conventionally referred to as offset.

Toyota does not recommend using the following:

- Wheels of different sizes or types
- Used wheels
- Bent wheels that have been straightened

■ When replacing wheels

The wheels of your vehicle are equipped with tire pressure warning valves and transmitters that allow the tire pressure warning system to provide advance warning in the event of a loss in tire inflation pressure. Whenever wheels are replaced, the tire pressure warning valves and transmitters must be installed. (→P.336)

■ When removing the wheel ornament (vehicles with a wheel cap clip)

Remove the wheel ornament using the wheel cap clip*.

*: The wheel cap clip is installed in the glove box. (→P.298)

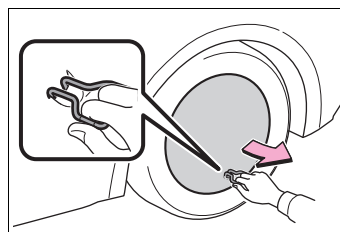

⚠ WARNING

■ When replacing wheels

- Do not use wheels that are a different size from those recommended in the Owner's Manual, as this may result in a loss of handling control.
- Never use an inner tube in a leaking wheel which is designed for a tubeless tire. Doing so may result in an accident, causing death or serious injury.

■ When installing the wheel nuts

- Be sure to install the wheel nuts with the tapered ends facing inward (→P.402). Installing the nuts with the tapered ends facing outward can cause the wheel to break and eventually cause the wheel to come off while driving, which could lead to an accident resulting in death or serious injury.

⚠ WARNING

- Never use oil or grease on the wheel bolts or wheel nuts. Oil and grease may cause the wheel nuts to be excessively tightened, leading to bolt or disc wheel damage. In addition, the oil or grease can cause the wheel nuts to loosen and the wheel may fall off, causing an accident and resulting in death or serious injury. Remove any oil or grease from the wheel bolts or wheel nuts.

■ Use of defective wheels prohibited

Do not use cracked or deformed wheels. Doing so could cause the tire to leak air during driving, possibly causing an accident.

⚠ NOTICE**■ Replacing tire pressure warning valves and transmitters**

- Because tire repair or replacement may affect the tire pressure warning valves and transmitters, make sure to have tires serviced by any authorized Toyota retailer or Toyota authorized repairer, or any reliable repairer. In addition, make sure to purchase your tire pressure warning valves and transmitters at any authorized Toyota retailer or Toyota authorized repairer, or any reliable repairer.
- Ensure that only genuine Toyota wheels are used on your vehicle. Tire pressure warning valves and transmitters may not work properly with non-genuine wheels.

Aluminum wheel precautions (if equipped)

- use with your aluminum wheels.
- When rotating, repairing or changing your tires, check that the wheel nuts are still tight after driving 1600 km (1000 miles).
- Be careful not to damage the aluminum wheels when using tire chains.
- Use only Toyota genuine balance weights or equivalent and a plastic or rubber hammer when balancing your wheels.
- Use only Toyota wheel nuts and wheel nut wrenches designed for

Air conditioning filter

The air conditioning filter must be changed regularly to maintain air conditioning efficiency.

Removing the air conditioning filter

- 1 Turn the power switch off.
- 2 Open the glove box. Slide off the damper.

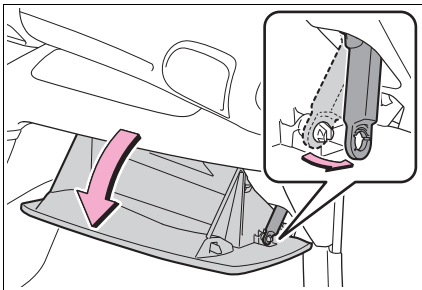

- 3 Push in the glove box on the vehicle's outer side to disconnect the 2 claws. Then pull out the glove box and disconnect the lower claws.

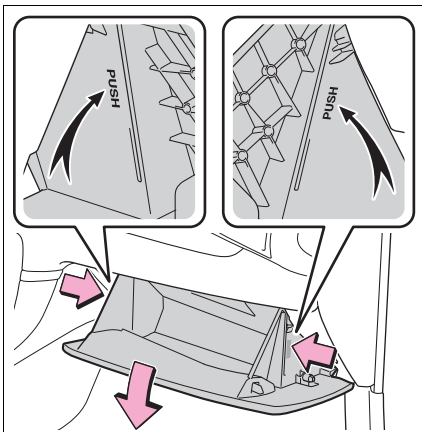

- 4 Pull out the glove box and disconnect the lower claws.

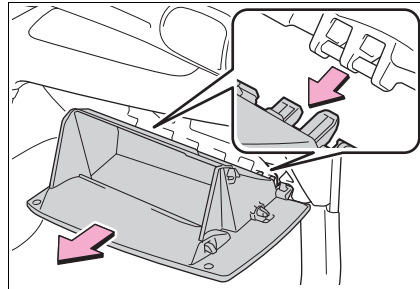

- 5 Unlock the filter cover (A), pull the filter cover out of the claws (B), and remove the filter cover.

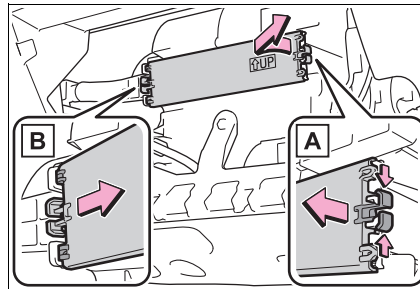

- 6 Remove the filter (type A) or filter case. (type B)

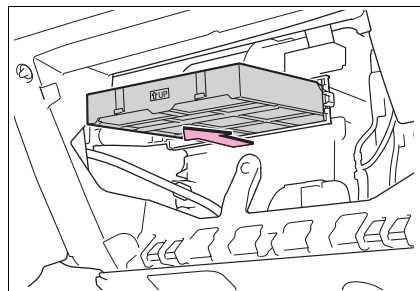

- 7 Replace the air conditioning filter with a new one.

The "↑ UP" marks shown on the filter

and the filter case should be pointing up.

► Type A

Replace the air conditioning filter.

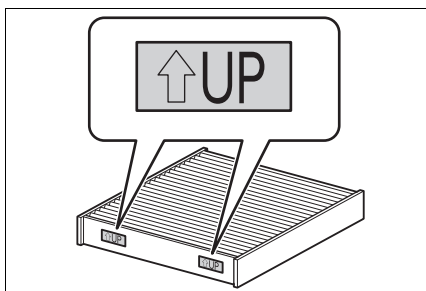

► Type B

Remove the air conditioning filter from the filter case and replace it.

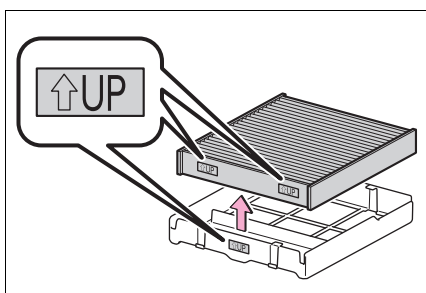

■ **Checking interval**

Inspect and replace the air conditioning filter according to the maintenance schedule. In dusty areas or areas with heavy traffic flow, early replacement may be required. (For scheduled maintenance information, please refer to the "Toyota Service Booklet" or "Toyota Warranty Booklet".)

■ **If air flow from the vents decreases dramatically**

The filter may be clogged. Check the filter and replace if necessary.

 NOTICE

■ **When using the air conditioning system**

Make sure that a filter is always installed. Using the air conditioning system without a filter may cause damage to the system.

■ **To prevent damage to the filter cover**

When moving the filter cover in the direction of arrow to release the fitting, pay attention not to apply excessive force to the claws. Otherwise, the claws may be damaged.

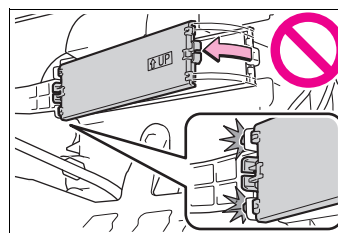

Cleaning the hybrid battery (traction battery) air intake vent and filter

To prevent the fuel economy from being affected, visually inspect the hybrid battery (traction battery) air intake vent periodically for dust and clogs. If it is dusty or clogged or if “Maintenance Required for Traction Battery Cooling Parts See Owner’s Manual” is displayed on the multi-information display, clean the air intake vent using the following procedures:

Cleaning the air intake vent

Remove the dust from the air intake vent with a vacuum cleaner, etc.

Make sure to only use a vacuum to suck out dust and clogs. Attempting to blow out dust and clogs using an air-gun, etc. may push it into the air intake vent. (→P.350)

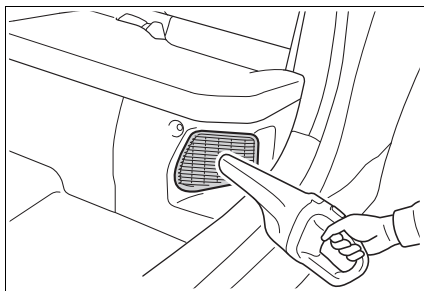

If dust and clogs cannot be completely removed

If dust and clogs cannot be completely removed with the air intake vent cover installed, remove the cover and clean the filter.

- 1 Turn the power switch off.
- 2 Using a flathead screwdriver, remove the air intake vent cover.

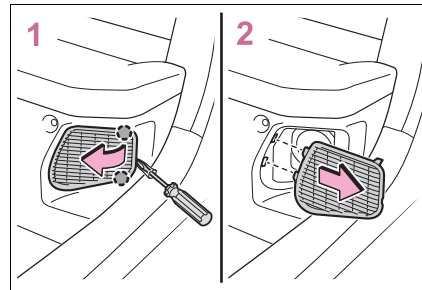

- 1 Pull the cover as shown in the illustration to disengage the 2 claws, starting from the claw in the upper right corner.
- 2 Pull the cover toward the side of the vehicle to remove it.
- 3 Remove the air intake vent filter.

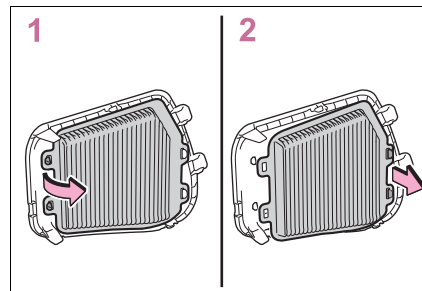

- 1 Disengage the 2 claws as shown in the illustration.
- 2 Disengage the 2 tabs and

remove the filter from cover as shown in the illustration.

- 4 Remove the dust and clogs from the filter using a vacuum cleaner, etc.

Make sure to also remove the dust and clogs from the inside of the air intake vent cover.

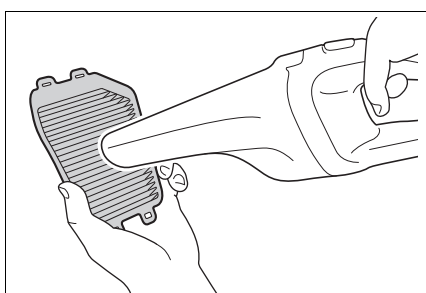

- 5 Reinstall the filter to the cover.

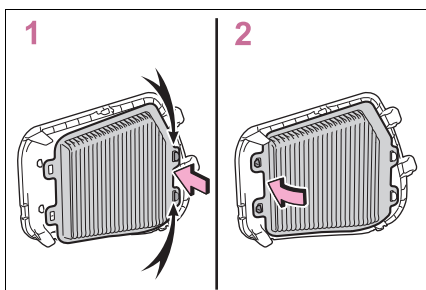

- 1 Engage the filter to the 2 tabs as shown in the illustration.
- 2 Engage the 2 claws to install the filter.

Make sure that the filter is not crooked or deformed when installing it.

- 6 Install the air intake vent cover.

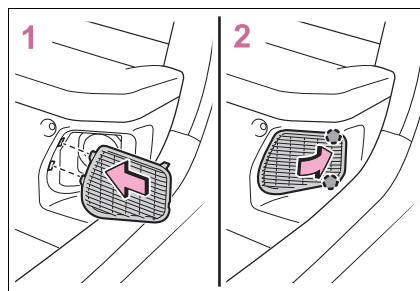

- 1 Insert the tab of the cover as shown in the illustration.
- 2 Push the cover to engage the 2 claws.

■ Scheduled maintenance of the air intake vent

Refer to "Toyota Service Booklet" or "Toyota Warranty Booklet".

■ Cleaning the air intake vent

- Dust in the air intake vent may interfere with the cooling of the hybrid battery (traction battery). If charging/discharging of the hybrid battery (traction battery) becomes limited, the distance that the vehicle can be driven using the electric motor (traction motor) may be reduced and the fuel economy may be reduced. Inspect and clean the air intake vent periodically.
- Improper handling of the air intake vent cover and filter may result in damage to them. If you have any concerns about cleaning the filter, contact any authorized Toyota retailer or Toyota authorized repairer, or any reliable repairer.

■ If "Maintenance Required for Traction Battery Cooling Parts See Owner's Manual" is displayed on the multi-information display

- If this warning message is displayed on the multi-information display, remove the air intake vent cover and

- clean the filter. (→P.348)
- After cleaning the air intake vent, start the hybrid system and check that the warning message is no longer displayed. After the hybrid system is started, it may be necessary to drive the vehicle up to approximately 20 minutes before the warning message disappears. If the warning message does not disappear after driving for appropriately 20 minutes, have the vehicle inspected by any authorized Toyota retailer or Toyota authorized repairer, or any reliable repairer.

WARNING

■ **When cleaning the air intake vent**

- Do not use water or other liquids to clean the air intake vent. If water is applied to the hybrid battery (traction battery) or other components, a malfunction or fire may occur.
- Before cleaning the air intake vent, make sure to turn the power switch off to stop the hybrid system.

■ **When removing the air intake vent cover**

Do not touch the service plug located near the air intake vent. (→P.80)

NOTICE

■ **When cleaning the air intake vent**

When cleaning the air intake vent, make sure to only use a vacuum to suck out dust and clogs. If a compressed air blow gun, etc. is used to blow out dust and clogs, the dust or clogs may be pushed into the air intake vent, which may affect the performance of the hybrid battery (traction battery) and cause a malfunction.

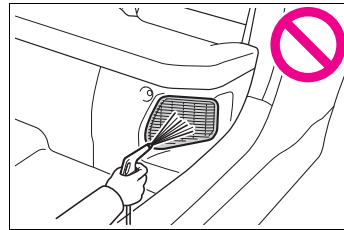

■ **To prevent damage to the vehicle**

- Do not allow water or foreign matter to enter the air intake vent when the cover is removed.
- Carefully handle the removed filter so that it will not be damaged. If the filter is damaged, have it replaced with a new filter by any authorized Toyota retailer or Toyota authorized repairer, or any reliable repairer.
- Make sure to reinstall the filter and cover to their original positions after cleaning.

**NOTICE**

- Do not install anything to the air intake vent other than the exclusive filter for this vehicle or use the vehicle without the filter installed.

■ **If “Maintenance Required for Traction Battery Cooling Parts See Owner’s Manual” is displayed on the multi-information display**

If the vehicle is continuously driven with the warning message (indicating that charging/discharging of the hybrid battery [traction battery] may become limited) displayed, the hybrid battery (traction battery) may malfunction. If the warning message is displayed, clean the air intake vent immediately.

Wireless remote control/electronic key battery

Replace the battery with a new one if it is depleted.

As the key may be damaged if the following procedure is not performed properly, it is recommended that key battery replacement be performed by any authorized Toyota retailer or Toyota authorized repairer, or any reliable repairer.

■ **If the electronic key battery is depleted**

The following symptoms may occur:

- The smart entry & start system (if equipped) and wireless remote control will not function properly.
- The operational range will be reduced.

Items to prepare

- Flathead screwdriver
- Small flathead screwdriver
- Lithium battery CR2032 (vehicles without a smart entry & start system), or CR2450 (vehicles with a smart entry & start system)

■ **Use a CR2032 (vehicles without a smart entry & start system) or CR2450 (vehicles with a smart entry & start system) lithium battery**

- Batteries can be purchased at any authorized Toyota retailer or Toyota authorized repairer, or any reliable

repairer, local electrical appliance shops or camera stores.

- Replace only with the same or equivalent type recommended by the manufacturer.
- Dispose of used batteries according to local laws.

Replacing the battery

- ▶ Vehicles without a smart entry & start system

1 Remove the key cover.

To prevent damage to the key, cover the tip of the flathead screwdriver with a rag.

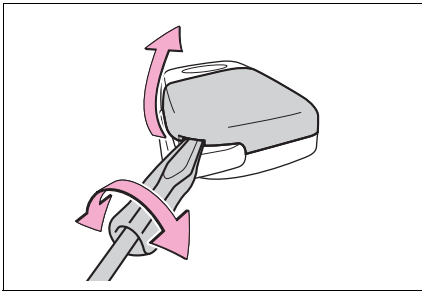

2 Remove the battery cover.

Use a screwdriver of an appropriate size. Forcedly prying may cause the cover damaged.

If the battery cover is difficult to remove, lift the edge to remove it.

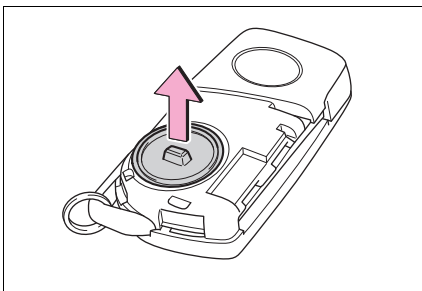

3 Remove the depleted battery using a small flathead screwdriver.

When removing the battery, use a screwdriver of an appropriate size.

Insert a new battery with the “+” terminal facing up.

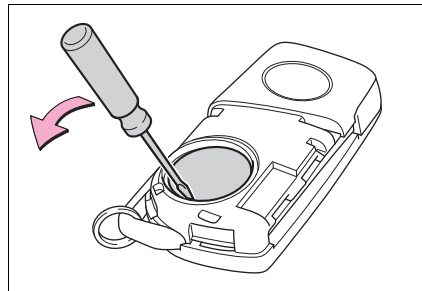

4 Install the battery cover with the tab facing up.

Push the entire edge of the battery cover into the key.

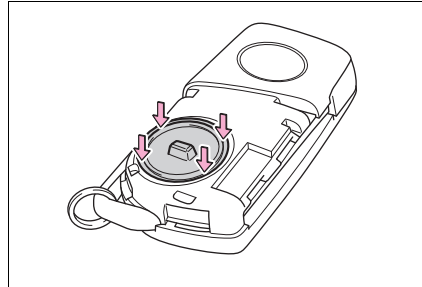



5 Install the key cover.

Align the key cover with the key and then press it straight into the key.

Make sure that the key cover is securely installed without any gaps

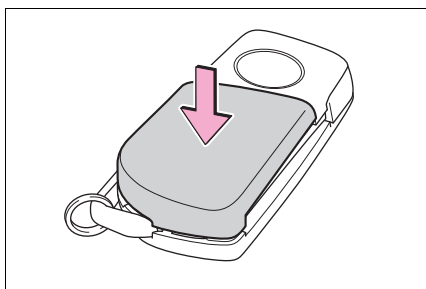
between it and the key.



6 Operate the  or  switch and check that the doors can be locked/unlocked.

► Vehicles with a smart entry & start system

1 Release the lock and remove the mechanical key.

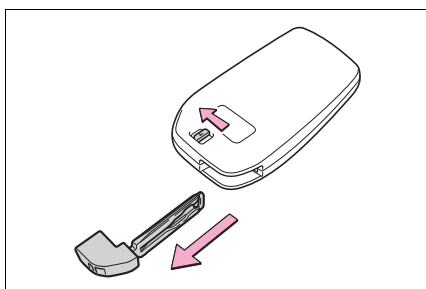

2 Remove the key cover.

Use a screwdriver of an appropriate size. Forcedly prying may cause the cover damaged.

To prevent damage to the key, cover the tip of the flathead screwdriver with a

rag.

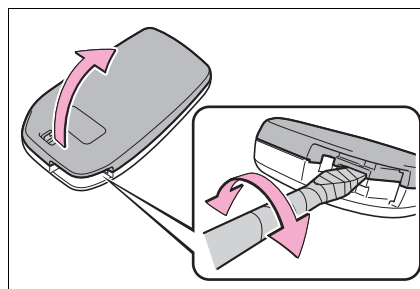

3 Remove the depleted battery using a small flathead screwdriver.



When removing the cover, the electronic key module may stick to the cover and the battery may not be visible. In this case, remove the electronic key module in order to remove the battery.

When removing the battery, use a screwdriver of an appropriate size.

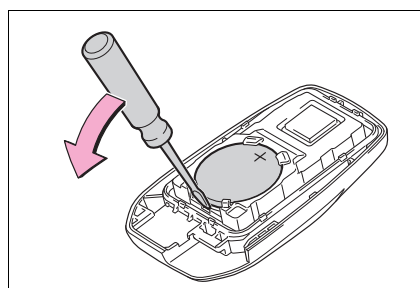
Insert a new battery with the “+” terminal facing up.



4 When installing the key cover and mechanical key, install by conducting step **2** and step **1** with the directions reversed.

5 Operate the  or  switch and check that the doors can be locked/unlocked.

⚠ WARNING

■ **Removed battery and other parts**

These parts are small and if swallowed by a child, they can cause choking. Keep away from children. Failure to do so could result in death or serious injury.

■ **Lithium battery precautions**

CAUTION
RISK OF EXPLOSION IF BATTERY IS REPLACED BY AN INCORRECT TYPE.
DISPOSE OF USED BATTERIES ACCORDING TO THE INSTRUCTIONS

⚠ NOTICE

■ **When replacing the battery**

Use a flathead screwdriver of appropriate size. Applying excessive force may deform or damage the cover.

■ **For normal operation after replacing the battery**

Observe the following precautions to prevent accidents:

- Always work with dry hands. Moisture may cause the battery to rust.
- Do not touch or move any other component inside the remote control.
- Do not bend either of the battery terminals.

■ **When removing the battery cover (vehicles without a smart entry & start system)**

Do not forcibly remove the battery cover, otherwise it may be damaged. If the battery cover is difficult to remove, lift the edge to remove it.

Checking and replacing fuses

If any of the electrical components do not operate, a fuse may have blown. If this happens, check and replace the fuses as necessary.

Checking and replacing fuses

- 1 Turn the power switch off.
 - 2 Open the fuse box cover.
- ▶ Engine compartment: type A fuse box

Push the tabs in and lift the lid off.

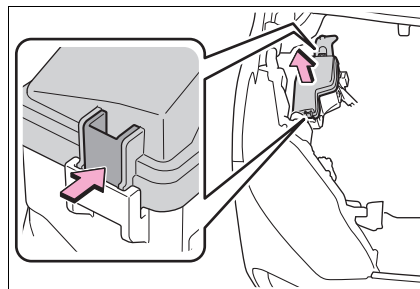

- ▶ Engine compartment: type B fuse box

Push the tabs in and lift the lid off.

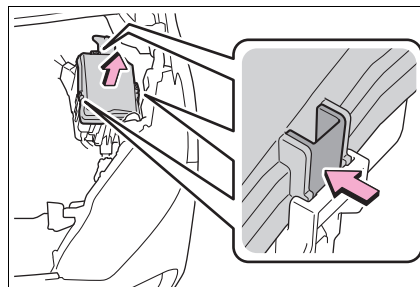

- ▶ Under the driver's side instrument panel (left-hand drive vehicles)

Remove the lid.

Make sure to push the claw when removing/installing the lid.

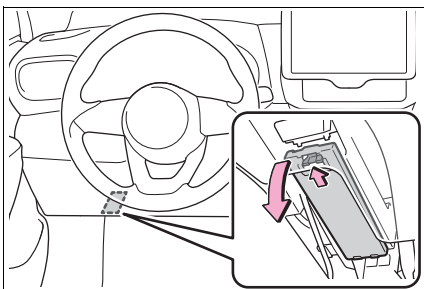

- ▶ Under the passenger's side instrument panel (right-hand drive vehicles)

Remove the cover, connector (if equipped) and then remove the lid.

Make sure to push the claw when removing/installing the lid.

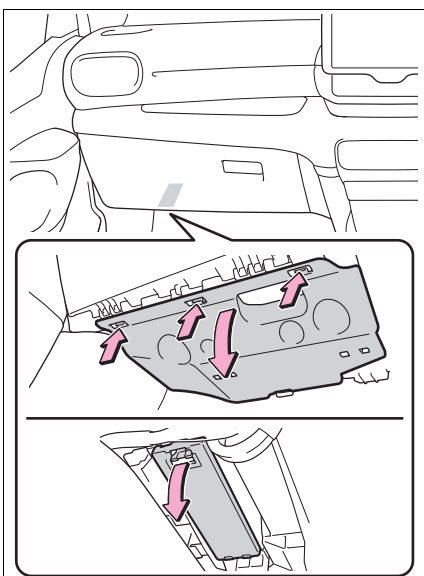

- ▶ Under the right-hand rear seat
Remove the 12-volt battery cover.
(→P.330)

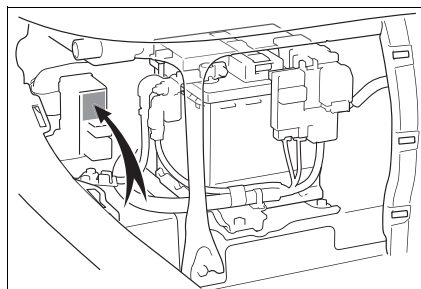

- 3 Remove the fuse with the pull-out tool.
Only type A fuse can be removed using the pullout tool.

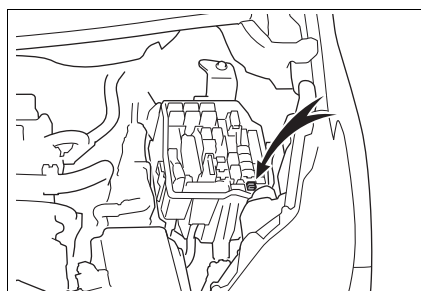

- 4 Check if the fuse is blown.

Replace the blown fuse with a new fuse of an appropriate amperage rating. The amperage rating can be found on the fuse box lid.

- ▶ Type A

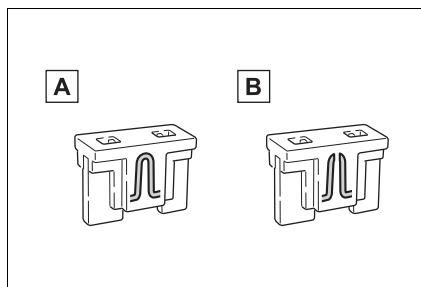

A Normal fuse

B Blown fuse

▶ Type B

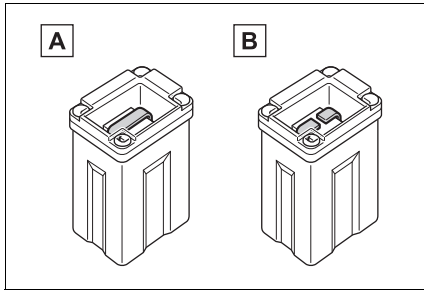

A Normal fuse

B Blown fuse

▶ Type C

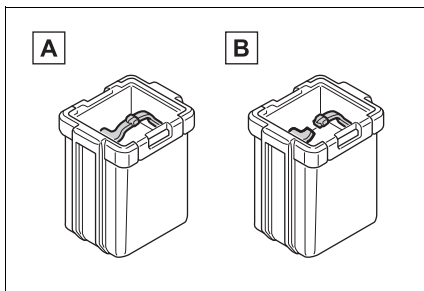

A Normal fuse

B Blown fuse

▶ Type D

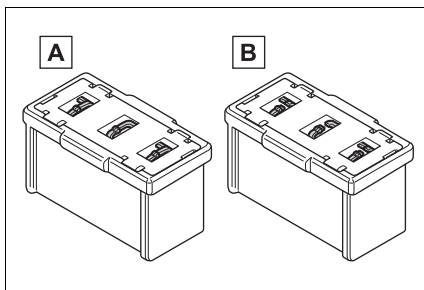

A Normal fuse

B Blown fuse

■ **After a fuse is replaced**

- When installing the lid, make sure that the tab is installed securely.
- If the lights do not turn on even after the fuse has been replaced, a bulb may need replacement. (→P.357)
- If the replaced fuse blows again, have the vehicle inspected by any authorized Toyota retailer or Toyota authorized repairer, or any reliable repairer.

■ **If there is an overload in a circuit**

The fuses are designed to blow, protecting the wiring harness from damage.

■ **When replacing light bulbs**

Toyota recommends that you use genuine Toyota products designed for this vehicle.

Because certain bulbs are connected to circuits designed to prevent overload, non-genuine parts of parts not designed for this vehicle may be unusable.

⚠ WARNING

■ **To prevent system breakdowns and vehicle fire**

Observe the following precautions. Failure to do so may cause damage to the vehicle, and possibly a fire or injury.

- Never use a fuse of a higher amperage rating than that indicated, or use any other object in place of a fuse.
- Always use a genuine Toyota fuse or equivalent. Never replace a fuse with a wire, even as a temporary fix.
- Do not modify the fuses or fuse boxes.

 NOTICE

■ Before replacing fuses

Have the cause of electrical overload determined and repaired by any authorized Toyota retailer or Toyota authorized repairer, or any reliable repairer as soon as possible.

■ When installing the fuse box cover (Engine compartment: type A and type B fuse boxes)

Press the fuse box cover, when installing, after aligning all of the claw positions. Otherwise, the claws may be damaged.

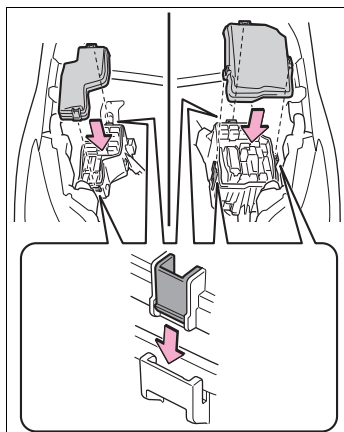
Light bulbs

You may replace the following bulbs by yourself. The difficulty level of replacement varies depending on the bulb. As there is a danger that components may be damaged, we recommend that replacement is carried out by any authorized Toyota retailer or Toyota authorized repairer, or any reliable repairer.

Preparing for light bulb replacement

Check the wattage of the light bulb to be replaced. (→P.428)

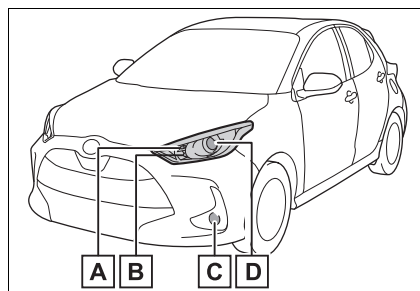
Bulb locations
► Front

- A** Front position lights (bulb type)
- B** Front turn signal lights (bulb type)
- C** Front fog lights (bulb type)
- D** Headlights (bulb type)

► Rear

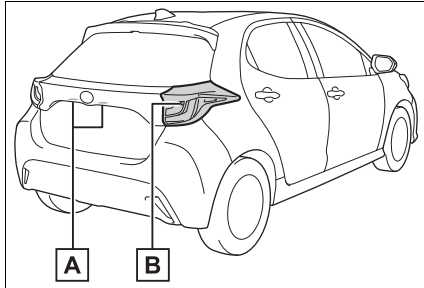

A License plate light

B Rear turn signal lights (bulb type)

■ **Lights that need to be replaced by any authorized Toyota retailer or Toyota authorized repairer, or any reliable repairer**

- Headlights (LED type)
- Front fog lights (LED type)
- Front position lights (LED type)
- Front turn signal lights (LED type)
- Daytime running lights
- Side turn signal lights
- Tail lights
- Stop lights
- Back-up light
- Rear fog light
- Rear turn signal lights (LED type)
- High mounted stoplight

■ **LED light bulbs**

The lights other than the following lights each consist of a number of LEDs. If any of the LEDs burn out, take your vehicle

to any authorized Toyota retailer or Toyota authorized repairer, or any reliable repairer to have the light replaced.

- Headlights (bulb type)
- Front position lights (bulb type)
- Front turn signal lights (bulb type)
- Front fog lights (bulb type)
- Rear turn signal lights (bulb type)
- License plate light

■ **Condensation build-up on the inside of the lens**

Temporary condensation build-up on the inside of the headlight lens does not indicate a malfunction. Contact any authorized Toyota retailer or Toyota authorized repairer, or any reliable repairer for more information in the following situations:

- Large drops of water have built up on the inside of the lens.
- Water has built up inside the headlight.

■ **When replacing light bulbs**

→P.356

Replacing light bulbs

■ **Headlights (bulb type)**

- 1 Unplug the connector.

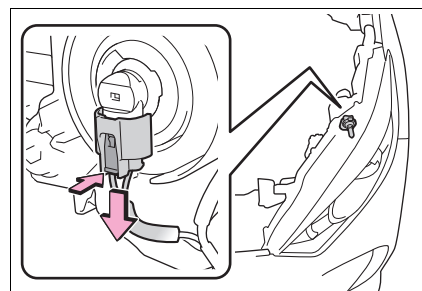

- 2** Turn the bulb base counter-clockwise.

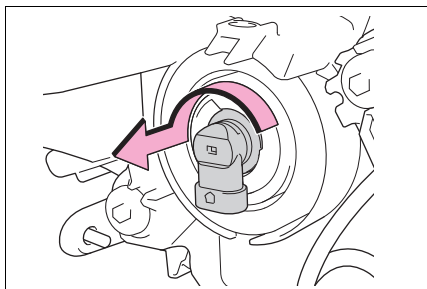

- 3** Replace the light bulb.

- 4** Install the bulb base.

Align the 3 tabs on the light bulb with the mounting and insert.

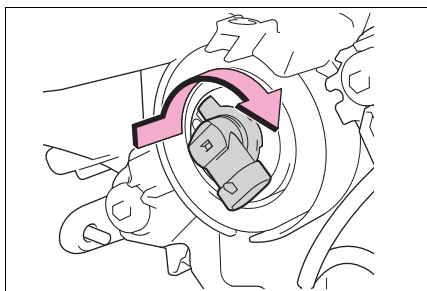

- 5** Plug the connector.

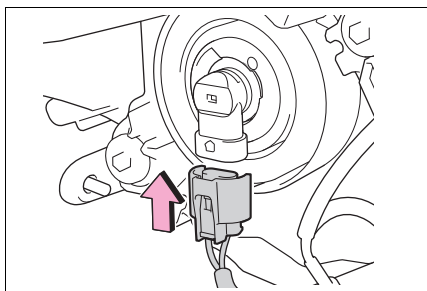

- 6** Secure the bulb base.

Shake the bulb base gently to check that it is not loose, turn the headlights on once and visually confirm that no

light is leaking through the mounting.

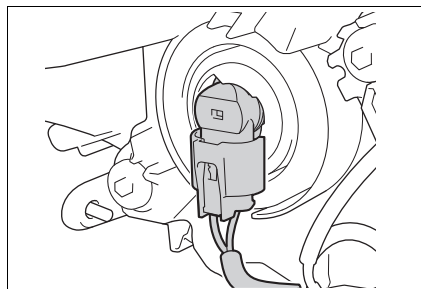

■ Front position lights (bulb type)

- 1** Turn the bulb base counter-clockwise.

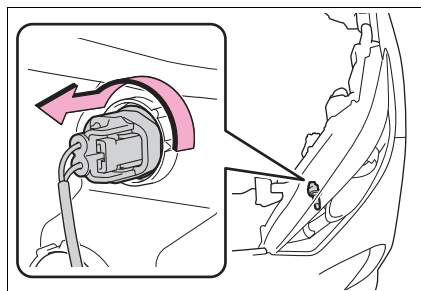

- 2** Remove light bulb.

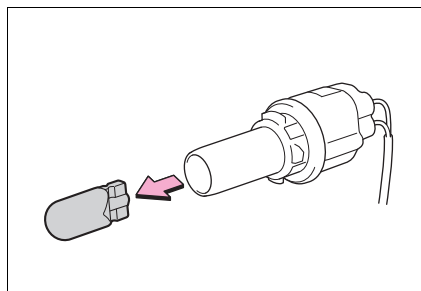

- 3** When installing, reverse the steps listed.

■ **Front turn signal lights (bulb type)**

- 1 Turn the bulb base counter-clockwise.

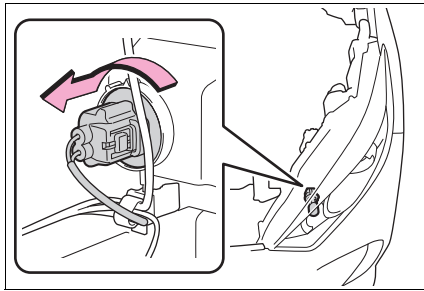

- 2 Remove the light bulb.

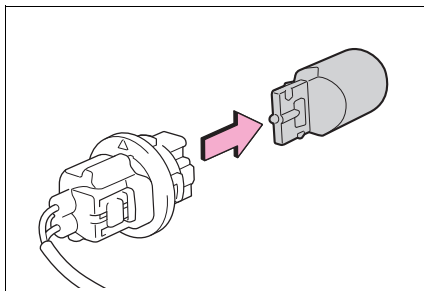

- 3 When installing, reverse the steps listed.

■ **Front fog lights (bulb type)**

- 1 To allow enough working space, turn the steering wheel.

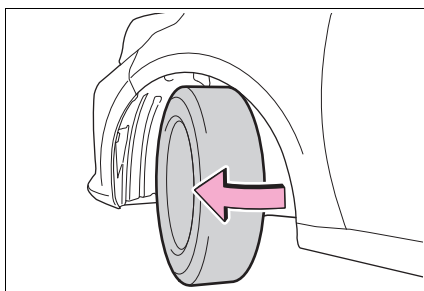

- 2 Remove the screws and clips.

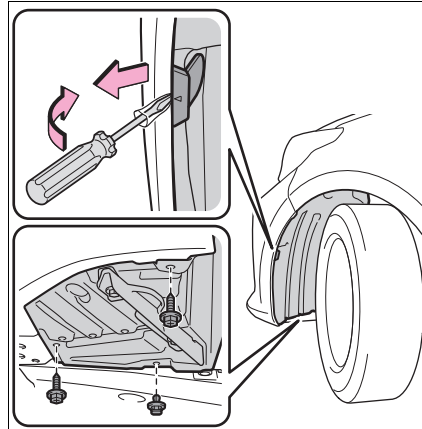

- 3 Partly remove the fender liner.

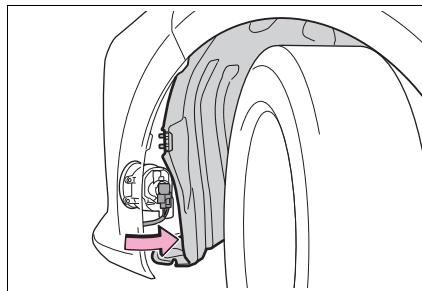

- 4 Unplug the connector.

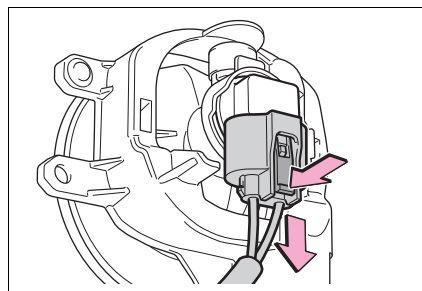

- 5** Turn the bulb base counter-clockwise.

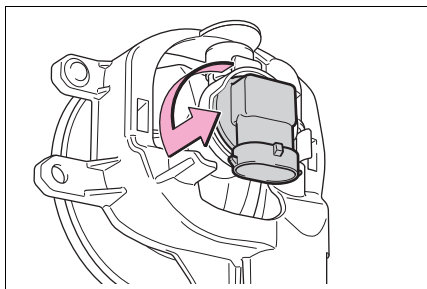

- 6** Set a new light bulb.

Align the 3 tabs on the light bulb with the mounting, and insert. Turn it clockwise to set.

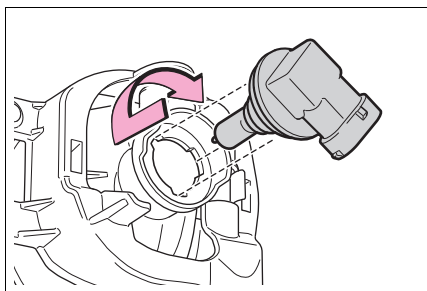

- 7** Set the connector.

Shake the bulb base gently to check that it is not loose, turn the front fog lights on once and visually confirm that no light is leaking through the mounting.

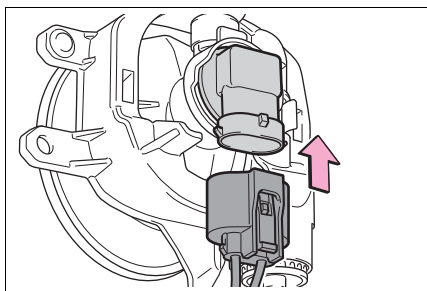

- 8** Reinstall the fender liner.

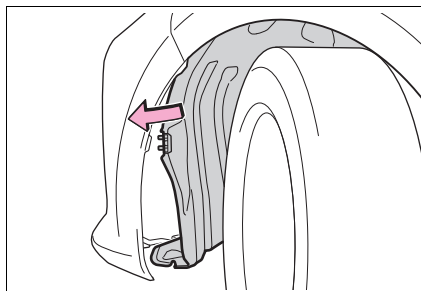

- 9** Reinstall the screws and clips.

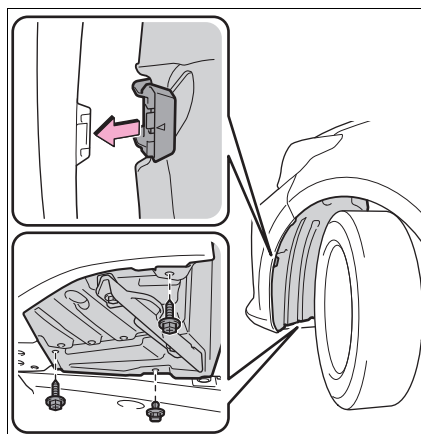

■ Rear turn signal lights (bulb type)

- 1** Open the back door.
- 2** Remove the 2 bolts and pull the lamp assembly toward the rear of the vehicle to remove it.

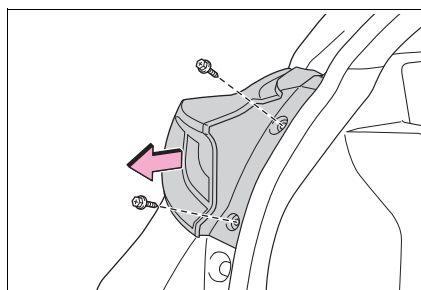

- 3** Turn the bulb base counter-clockwise.

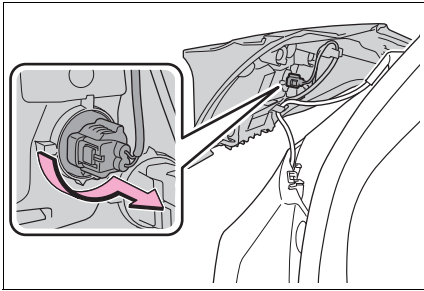

- 4** Remove the light bulb.

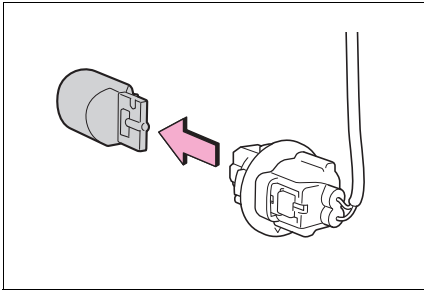

- 5** When installing the light bulb, install by conducting **3** and **4** with the directions reversed.

- 6** Install the lamp assembly.

Align the guides **A** and pins **B** on the lamp assembly with the mounting when

installing it.

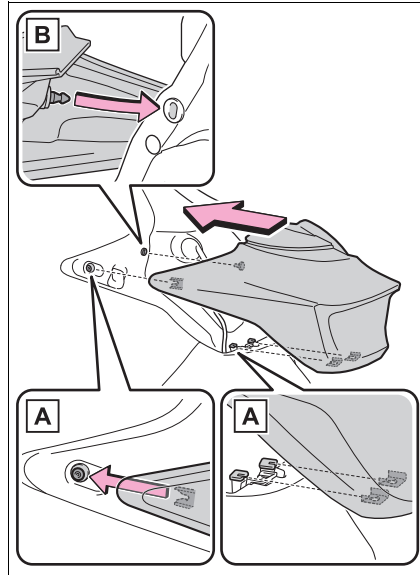

- 7** Install the 2 bolts.

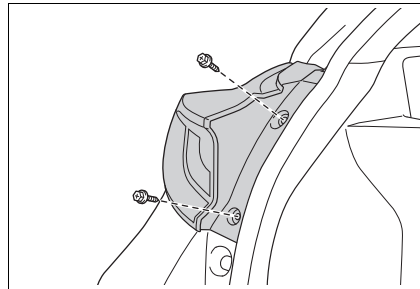

■ License plate light

1 Remove the lens.

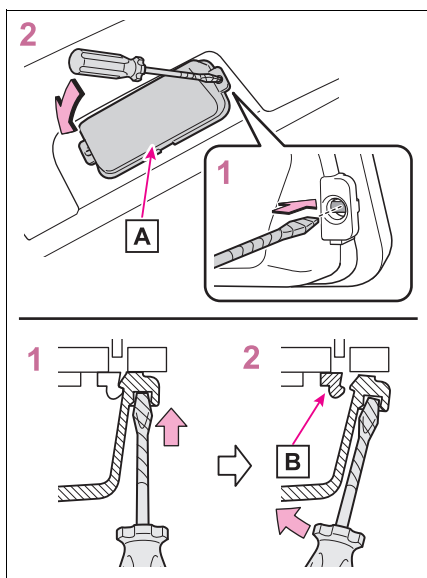

- 1 Insert a small flathead screwdriver, etc., into either the right or left hole of the lens.
- 2 Tilt the screwdriver in the direction of the arrow shown in the illustration so as to release the fitting portion, and then remove the lens.

To prevent damage to the vehicle, wrap the tip of the screwdriver with tape.

A Lens

B Fitting portion

2 Remove the light bulb.

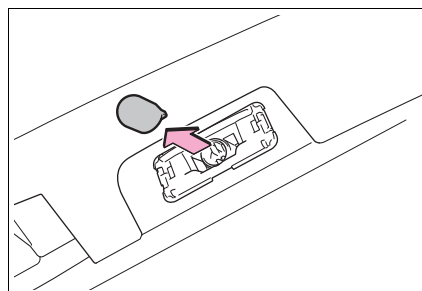

3 Install a new light bulb.

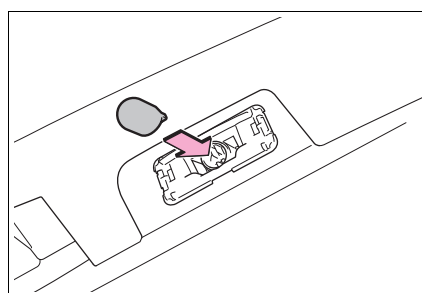

4 Install the lens.

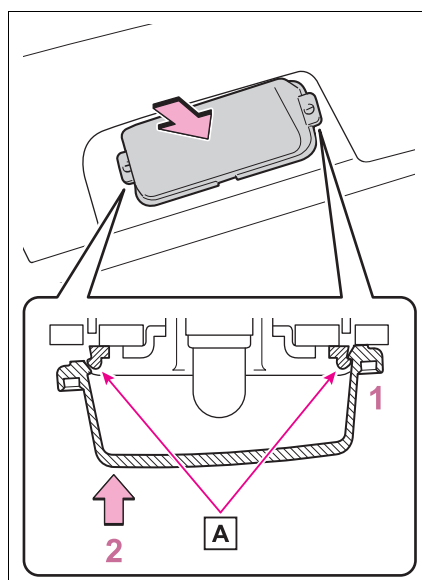

- 1 Fit the lens into either the right or left fitting portion.

2 Push the lens into place.

After installation, confirm that the lens is properly installed by gently pulling it.

A Fitting portion



WARNING

■ **Replacing light bulbs**

- Turn off the lights. Do not attempt to replace the bulb immediately after turning off the lights. The bulbs become very hot and may cause burns.
- Do not touch the glass portion of the light bulb with bare hands. When it is unavoidable to hold the glass portion, use and hold with a clean dry cloth to avoid getting moisture and oils on the bulb. Also, if the bulb is scratched or dropped, it may blow out or crack.
- Fully install light bulbs and any parts used to secure them. Failure to do so may result in heat damage, fire, or water entering the light unit. This may damage the lights or cause condensation to build up on the lens.

■ **To prevent damage or fire**

Make sure bulbs are fully seated and locked.

When trouble arises

7

7-1. Essential information

Emergency flashers **366**

If your vehicle has to be stopped in an emergency **366**

If the vehicle is submerged or water on the road is rising **367**

7-2. Steps to take in an emergency

If your vehicle needs to be towed **369**

If you think something is wrong **372**

If a warning light turns on or a warning buzzer sounds... **374**

If a warning message is displayed **383**

If you have a flat tire (vehicles with an emergency tire puncture repair kit) **386**

If you have a flat tire (vehicles with a spare tire) **397**

If the hybrid system will not start **405**

If you lose your keys **407**

If the electronic key does not operate properly (vehicles with a smart entry & start system) **407**

If the 12-volt battery is discharged **409**

If your vehicle overheats... **414**

If the vehicle becomes stuck **417**

Emergency flashers

The emergency flashers are used to warn other drivers when the vehicle has to be stopped on the road due to a breakdown, etc.

Operating instructions

Press the switch.

All the turn signal lights will flash.

To turn them off, press the switch once again.

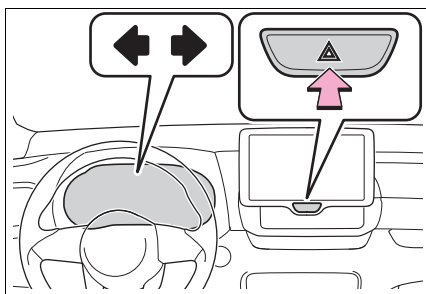

Emergency flashers

- If the emergency flashers are used for a long time while the hybrid system is not operating (while the “READY” indicator is not illuminated), the 12-volt battery may discharge.
- If any of the SRS airbags deploy (inflate) or in the event of a strong rear impact, the emergency flashers will turn on automatically. The emergency flashers will turn off automatically after operating for approximately 20 minutes. To manually turn the emergency flashers off, press the switch twice. (The emergency flashers may not turn on automatically depending on the force of the impact and conditions of the collision.)

If your vehicle has to be stopped in an emergency

Only in an emergency, such as if it becomes impossible to stop the vehicle in the normal way, stop the vehicle using the following procedure:

Stopping the vehicle

- 1 Steadily step on the brake pedal with both feet and firmly depress it.

Do not pump the brake pedal repeatedly as this will increase the effort required to slow the vehicle.

- 2 Shift the shift lever to N.
 - ▶ If the shift lever is shifted to N
- 3 After slowing down, stop the vehicle in a safe place by the road.
- 4 Stop the hybrid system.
 - ▶ If the shift lever cannot be shifted to N
- 3 Keep depressing the brake pedal with both feet to reduce vehicle speed as much as possible.
- 4 Perform the following procedure to stop the hybrid system:
 - ▶ Vehicles without a smart entry & start system

Turn the power switch to ACC.

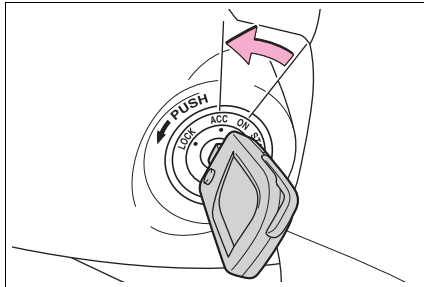

- ▶ Vehicles with a smart entry & start system

Press and hold the power switch for 2 consecutive seconds or more, or press it briefly 3 times or more in succession.

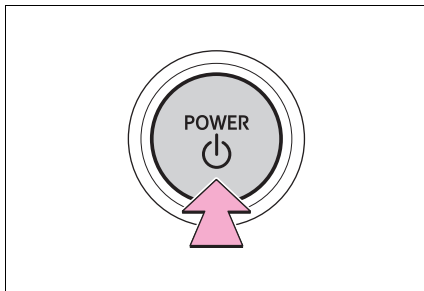

- 5 Stop the vehicle in a safe place by the road.

WARNING

■ If the hybrid system has to be turned off while driving

- Power assist for the steering wheel will be lost, making the steering wheel heavier to turn. Decelerate as much as possible before turning off the hybrid system.
- Vehicles without a smart entry & start system: Never attempt to remove the key, as doing so will lock the steering wheel.

If the vehicle is submerged or water on the road is rising

This vehicle is not designed to be able to drive on roads that are deeply flooded with water. Do not drive on roads where the roads may be submerged or the water may be rising. It is dangerous to remain in the vehicle, if it anticipated that the vehicle will be flooded or set a drift. Remain calm and follow the following.

- If the door can be opened, open the door and exit the vehicle.
- If the door can not be opened, open the window using the power window switch and ensure an escape route.
- If the window can be opened, exit the vehicle through the window.
- If the door and window cannot be opened due to the rising water, remain calm, wait until the water level inside the vehicle rises to the point that the water pressure inside of the vehicle equals the water pressure outside of the vehicle and then open the door after waiting for the rising water to enter the vehicle, and exit the vehicle. When the outside water level exceeds half the height of the door, the door cannot be opened from the inside due to

water pressure.

■ **Water level exceeds the floor**

When the water level exceeds the floor and time has passed, the electrical equipment will get damaged, the power windows will not operate, the engine and motor stop, and the vehicle may not be able to get moving.

■ **Using an emergency escape hammer***

Laminated glass is used in the windshield on this vehicle. Laminated glass cannot be shattered with an emergency hammer*.

Tempered glass is used in the windows on this vehicle.

*: Contact any authorized Toyota retailer or Toyota authorized repairer, or any reliable repairer, or aftermarket accessory manufacturer for further information about an emergency hammer.



WARNING

■ **Caution while driving**

Do not drive on roads where the roads may be submerged or the water may be rising. Otherwise the vehicle may be damaged and cannot move, as well as become flooded and set a drift, which may lead to death.

If your vehicle needs to be towed

If towing is necessary, we recommend having your vehicle towed by any authorized Toyota retailer or Toyota authorized repairer, or any reliable repairer or commercial towing service, using a wheel-lift type truck or flatbed truck.

Use a safety chain system for all towing, and abide by all state/provincial and local laws.

WARNING

Observe the following precautions. Failure to do so may result in death or serious injury.

■ When towing the vehicle

Be sure to transport the vehicle with the front wheels raised or with all four wheels raised off the ground. If the vehicle is towed with the front wheels contacting the ground, the drivetrain and related parts may be damaged or electricity generated by the operation of the motor may cause a fire to occur depending on the nature of the damage or malfunction.

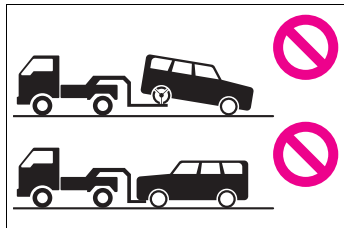

■ While towing

- When towing using cables or chains, avoid sudden starts, etc. which place excessive stress on the towing eyelets, cables or chains. The towing eyelets, cables or chains may become damaged, broken debris may hit people, and cause serious damage.
- Do not turn the power switch off. There is a possibility that the steering wheel is locked and cannot be operated.

■ Installing towing eyelets to the vehicle

Make sure that towing eyelets are installed securely. If not securely installed, towing eyelets may come loose during towing.

NOTICE

■ To prevent damage to the vehicle when towing using a wheel-lift type truck

- Do not tow the vehicle from the rear when the power switch is off. The steering lock mechanism is not strong enough to hold the front wheels straight.
- When raising the vehicle, ensure adequate ground clearance for towing at the opposite end of the raised vehicle. Without adequate clearance, the vehicle could be damaged while being towed.

■ To prevent damage to the vehicle when towing with a sling-type truck

Do not tow with a sling-type truck, either from the front or rear.

■ To prevent damage to the vehicle during emergency towing

Do not secure cables or chains to the suspension components.

Situations when it is necessary to contact dealers before towing

The following may indicate a problem with your transmission. Contact any authorized Toyota retailer or Toyota authorized repairer, or any reliable repairer or commercial towing service before towing.

- The hybrid system warning message is shown on the multi-information display and the vehicle does not move.
- The vehicle makes an abnormal sound.

Towing with a wheel-lift type truck

► From the front

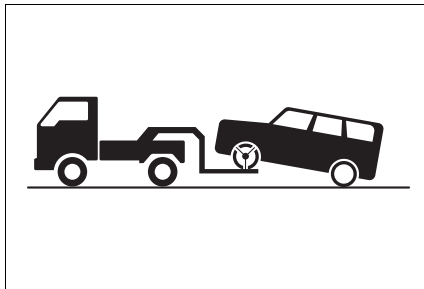

Release the parking brake.
Turn automatic mode off. (→P.185)

► From the rear

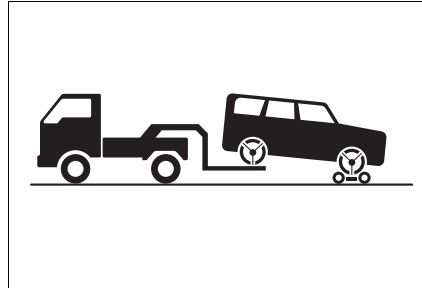

Use a towing dolly under the front wheels.

NOTICE

Towing with a sling-type truck

Do not tow with a sling-type truck to prevent body damage.

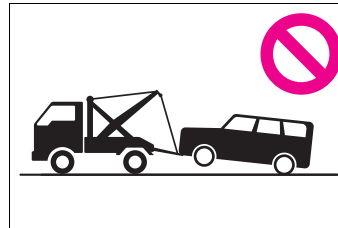

Using a flatbed truck

When using a flat-bed truck to transport the vehicle, use tire strapping belts. Refer to the owner's manual of the flat-bed truck for the tire strapping method.

In order to suppress vehicle movement during transportation, set the parking brake and turn the power switch off.

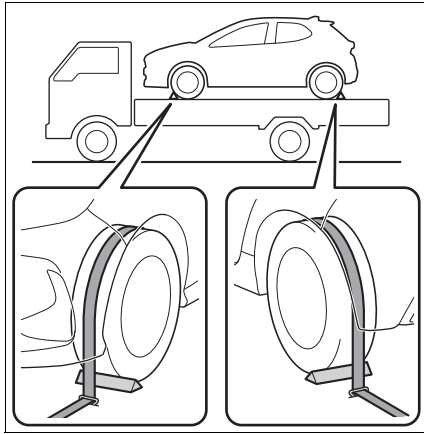

Emergency towing

If a tow truck is not available in an emergency, your vehicle may be temporarily towed using cables or chains secured to the emergency towing eyelets. This should only be attempted on hard surfaced roads for a short distance at under 30 km/h (18 mph).

A driver must be in the vehicle to steer and operate the brakes. The vehicle's wheels, drivetrain, axles, steering and brakes must be in good condition.

Emergency towing procedure

To have your vehicle towed by another vehicle, the towing eyelet must be installed to your vehicle. Install the towing eyelet using the following procedure.

- 1 Take out the wheel nut wrench and towing eyelet. (→P.398)

- 2 Remove the eyelet cover using a flathead screwdriver.

To protect the bodywork, place a rag between the screwdriver and the vehicle body as shown in the illustration.

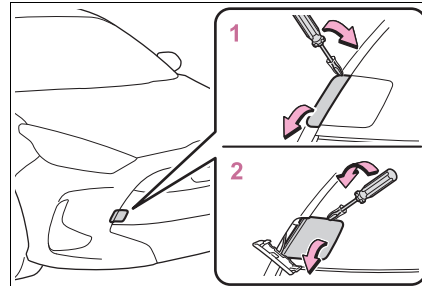

- 3 Insert the towing eyelet into the hole and tighten partially by hand.

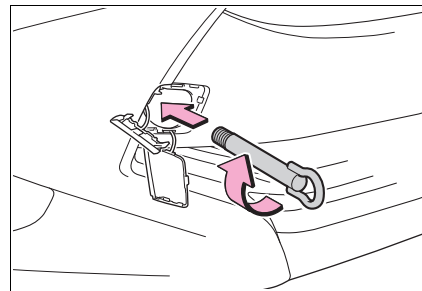

- 4 Tighten down the towing eyelet securely using a wheel nut wrench^{*1, 2} or hard metal bar.

^{*1}: If equipped

^{*2}: If your vehicles does not provide a wheel nut wrench, you can purchase it from any authorized Toyota retailer or Toyota authorized repairer, or any

reliable repairer.

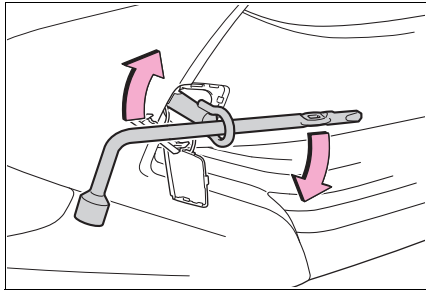

- 5 Securely attach cables or chains to the towing eyelet.

Take care not to damage the vehicle body.

- 6 Enter the vehicle being towed and start the hybrid system.

If the hybrid system does not start, turn the power switch to ON.

- 7 Shift the shift lever to N and release the parking brake.
When the shift lever cannot be shifted: →P.182

Turn automatic mode off. (→P.185)

■ While towing

If the hybrid system is off, the power assist for the brakes and steering will not function, making steering and braking more difficult.

■ Wheel nut wrench^{*1, 2}

Wheel nut wrench is installed in luggage compartment. (→P.398)

^{*1}: If equipped

^{*2}: If your vehicles does not provide a wheel nut wrench, you can purchase it from any authorized Toyota retailer or Toyota authorized repairer, or any reliable repairer.

If you think something is wrong

If you notice any of the following symptoms, your vehicle probably needs adjustment or repair. Contact any authorized Toyota retailer or Toyota authorized repairer, or any reliable repairer as soon as possible.

Visible symptoms

- Fluid leaks under the vehicle.
(Water dripping from the air conditioning after use is normal.)
- Flat-looking tires or uneven tire wear
- Engine coolant temperature gauge needle continually points higher than normal.

Audible symptoms

- Changes in exhaust sound
- Excessive tire squeal when cornering
- Strange noises related to the suspension system
- Pinging or other noises related to the hybrid system

Operational symptoms

- Engine missing, stumbling or running roughly
- Appreciable loss of power

- Vehicle pulls heavily to one side when braking
- Vehicle pulls heavily to one side when driving on a level road
- Loss of brake effectiveness, spongy feeling, pedal almost touches the floor

If a warning light turns on or a warning buzzer sounds

Calmly perform the following actions if any of the warning lights comes on or flashes. If a light comes on or flashes, but then goes off, this does not necessarily indicate a malfunction in the system. However, if this continues to occur, have the vehicle inspected by any authorized Toyota retailer or Toyota authorized repairer, or any reliable repairer.

Actions to the warning lights or warning buzzers

■ **Brake system warning light (warning buzzer)**

Warning light	Details/Actions
 (Red)	Indicates that: <ul style="list-style-type: none"> ● The brake fluid level is low; or ● The brake system is malfunctioning → Immediately stop the vehicle in a safe place and contact any authorized Toyota retailer or Toyota authorized repairer, or any reliable repairer. Continuing to drive the vehicle may be dangerous.

■ **Brake system warning light**

Warning light	Details/Actions
 (Yellow)	Indicates a malfunction in: <ul style="list-style-type: none"> ● The regenerative braking system; ● The electronically controlled brake system; or ● The parking brake system → Have the vehicle inspected by any authorized Toyota retailer or Toyota authorized repairer, or any reliable repairer immediately.

■ **High coolant temperature warning light* (warning buzzer)**

Warning light	Details/Actions
	Indicates that the engine coolant temperature is excessively high → Immediately stop the vehicle in a safe place. Handling method (→P.414)

*: This light illuminates on the multi-information display.

■ Hybrid system overheat warning light* (warning buzzer)

Warning light	Details/Actions
	Indicates the hybrid system has overheated → Stop the vehicle in a safe place. Handling method (→P.414)

*: This light illuminates on the multi-information display.

■ Charging system warning light*

Warning light	Details/Actions
	Indicates a malfunction in the vehicle's charging system → Immediately stop the vehicle in a safe place and contact any authorized Toyota retailer or Toyota authorized repairer, or any reliable repairer.

*: This light illuminates on the multi-information display.

■ Low engine oil pressure warning light* (warning buzzer)

Warning light	Details/Actions
	Indicates that the engine oil pressure is excessively low → Immediately stop the vehicle in a safe place and contact any authorized Toyota retailer or Toyota authorized repairer, or any reliable repairer.

*: This light illuminates on the multi-information display.

■ Malfunction indicator lamp (warning buzzer)

Warning light	Details/Actions
	Indicates a malfunction in: <ul style="list-style-type: none"> ● The hybrid system; ● The electronic engine control system; or ● The electronic throttle control system → Immediately stop the vehicle in a safe place and contact any authorized Toyota retailer or Toyota authorized repairer, or any reliable repairer.

■ SRS warning light (warning buzzer)

Warning light	Details/Actions
	<p>Indicates a malfunction in:</p> <ul style="list-style-type: none"> ● The SRS airbag system; or ● The seat belt pretensioner system <p>→ Have the vehicle inspected by any authorized Toyota retailer or Toyota authorized repairer, or any reliable repairer immediately.</p>

■ ABS warning light



Warning light	Details/Actions
	<p>Indicates a malfunction in:</p> <ul style="list-style-type: none"> ● The ABS; or ● The brake assist system <p>→ Have the vehicle inspected by any authorized Toyota retailer or Toyota authorized repairer, or any reliable repairer immediately.</p>

■ Inappropriate pedal operation warning light* (warning buzzer)

Warning light	Details/Actions
	<p>When a buzzer sounds:</p> <p>Indicates a malfunction in:</p> <ul style="list-style-type: none"> ● The Brake Override System ● The Drive-Start Control system <p>→ Have the vehicle inspected by any authorized Toyota retailer or Toyota authorized repairer, or any reliable repairer immediately.</p> <p>Indicates that the shift position was changed and Drive-Start Control was operated while depressing the accelerator pedal.</p> <p>→ Momentarily release the accelerator pedal.</p> <p>When a buzzer does not sound:</p> <p>Indicates that the accelerator and brake pedals are being depressed simultaneously, and the Brake Override System is operating.</p> <p>→ Release the accelerator pedal and depress the brake pedal.</p>

*: This light illuminates on the multi-information display.

■ Electric power steering system warning light (warning buzzer)

Warning light	Details/Actions
 (Red) or  (Yellow)	Indicates a malfunction in the EPS (Electric Power Steering) system → Have the vehicle inspected by any authorized Toyota retailer or Toyota authorized repairer, or any reliable repairer immediately.

■ Low fuel level warning light

Warning light	Details/Actions
	Vehicles without rear wiper: Indicates that remaining fuel is approximately 5.0 L (1.4 gal., 1.2 Imp. gal.) or less Vehicles with rear wiper: Indicates that remaining fuel is approximately 5.4 L (1.5 gal., 1.2 Imp. gal.) or less → Refuel the vehicle.

■ Driver's and front passenger's seat belt reminder light (warning buzzer*)

Warning light	Details/Actions
	Warns the driver and/or front passenger to fasten their seat belts → Fasten the seat belt. If the front passenger's seat is occupied, the front passenger's seat belt also needs to be fastened to make the warning light (warning buzzer) turn off.

*: Driver's and front passenger's seat belt warning buzzer:

The driver's and front passenger's seat belt warning buzzer sounds to alert the driver and front passenger that his or her seat belt is not fastened. If the seat belt is unfastened, the buzzer sounds intermittently for a certain period of time after the vehicle reaches a certain speed.

■ Rear passengers' seat belt reminder lights*¹ (warning buzzer*²)

Warning light	Details/Actions
	Warns the rear passengers to fasten their seat belts → Fasten the seat belt.

*¹: This light illuminates on the multi-information display.

378 7-2. Steps to take in an emergency

*2: Rear passengers' seat belt warning buzzer:

The rear passengers' seat belt warning buzzer sounds to alert the rear passenger that his or her seat belt is not fastened. If the seat belt is unfastened, the buzzer sounds intermittently for a certain period of time after the vehicle reaches a certain speed.

■ Tire pressure warning light

Warning light	Details/Actions
	<p>When the light comes on after blinking for approximately 1 minute (a buzzer does not sound):</p> <p>Malfunction in the tire pressure warning system → Have the system checked by any authorized Toyota retailer or Toyota authorized repairer, or any reliable repairer.</p> <p>When the light comes on (a buzzer sounds):</p> <p>Low tire inflation pressure from natural causes → Adjust the tire inflation pressure to the specified cold tire inflation pressure level. (→P.427)</p> <p>Low tire inflation pressure from flat tire → Immediately stop the vehicle in a safe place. Handling method (→P.381)</p>

■ LTA indicator* (warning buzzer)

Warning light	Details/Actions
 <p>(Orange) (if equipped)</p>	<p>Indicates a malfunction in the LTA (Lane Tracing Assist)</p> <p>→ Follow the instructions displayed on the multi-information display. (→P.229)</p>

*: This light illuminates on the multi-information display.

■ Toyota parking assist-sensor OFF indicator (warning buzzer)

Warning light	Details/Actions
 (Flashes) (if equipped)	<p>Indicates a malfunction in the Toyota parking assist-sensor function</p> <p>→ Have the vehicle inspected by any authorized Toyota retailer or Toyota authorized repairer, or any reliable repairer immediately.</p> <p>Indicates that the system is temporarily unavailable, possibly due to a sensor being dirty or covered with ice, etc.</p> <p>→ Follow the instructions displayed on the multi-information display. (→P.255)</p>

■ “RCTA OFF” indicator (warning buzzer)

Warning light	Details/Actions
 (Flashes) (if equipped)	<p>Indicates a malfunction in the RCTA (Rear Crossing Traffic Alert) function</p> <p>→ Have the vehicle inspected by any authorized Toyota retailer or Toyota authorized repairer, or any reliable repairer immediately.</p> <p>Indicates that the rear bumper around the radar sensor is covered with dirt, etc. (→P.249)</p> <p>→ Follow the instructions displayed on the multi-information display. (→P.261)</p>

■ PKSB OFF indicator

Warning light	Details/Actions
 (if equipped)	<p>When a buzzer sounds:</p> <p>Indicates a malfunction in the PKSB (Parking Support Brake) system</p> <p>→ Have the vehicle inspected by any authorized Toyota retailer or Toyota authorized repairer, or any reliable repairer immediately.</p> <p>When a buzzer does not sound:</p> <p>Indicates that the system is temporarily unavailable, possibly due to a sensor being dirty or covered with ice, etc.</p> <p>→ Follow the instructions displayed on the multi-information display. (→P.269, 383)</p>

■ PCS warning light

Warning light	Details/Actions
 <p>(Flashes or illuminates) (if equipped)</p>	<p>When a buzzer sounds simultaneously: Indicates a malfunction has occurred in the PCS (Pre-Collision System). → Have the vehicle inspected by any authorized Toyota retailer or Toyota authorized repairer, or any reliable repairer immediately.</p> <p>When a buzzer does not sound: The PCS (Pre-Collision System) has become temporarily unavailable, corrective action may be necessary. → Follow the instructions displayed on the multi-information display. (→P.207, 383)</p> <p>If the PCS (Pre-Collision System) or VSC (Vehicle Stability Control) system is disabled, the PCS warning light will illuminate. → P.278</p>

■ Slip indicator

Warning light	Details/Actions
	<p>Indicates a malfunction in:</p> <ul style="list-style-type: none"> ● The VSC system; ● The TRC system; or ● The hill-start assist control system <p>→ Have the vehicle inspected by any authorized Toyota retailer or Toyota authorized repairer, or any reliable repairer immediately.</p>

■ Parking brake indicator

Warning light	Details/Actions
 <p>(Flashes)</p>	<p>It is possible that the parking brake is not fully engaged or released → Operate the parking brake switch once again.</p> <p>This light comes on when the parking brake is not released. If the light turns off after the parking brake is fully released, the system is operating normally.</p>

■ Brake hold operated indicator

Warning light	Details/Actions
	Indicates a malfunction in the brake hold system → Have the vehicle inspected by any authorized Toyota retailer or Toyota authorized repairer, or any reliable repairer immediately.

■ Warning buzzer

In some cases, the buzzer may not be heard due to being in a noisy location or audio sound.

■ Front passenger detection sensor, seat belt reminder and warning buzzer

- If luggage is placed on the front passenger seat, the front passenger detection sensor may cause the warning light to flash and the warning buzzer to sound even if a passenger is not sitting in the seat.
- If a cushion is placed on the seat, the sensor may not detect a passenger, and the warning light may not operate properly.

■ If the malfunction indicator lamp comes on while driving

For some models, the malfunction indicator lamp will come on if the fuel tank becomes completely empty. If the fuel tank is empty, refuel the vehicle immediately. The malfunction indicator lamp will go off after several trips.

If the malfunction indicator lamp does not go off, contact any authorized Toyota retailer or Toyota authorized repairer, or any reliable repairer as soon as possible.

■ Electric power steering system warning light (warning buzzer)

When the 12-volt battery charge becomes insufficient or the voltage temporarily drops, the electric power steering system warning light may come on and the warning buzzer may sound.

■ When the tire pressure warning light comes on

Inspect the tires to check if a tire is punctured.

If a tire is punctured: →P.386, 397

If none of the tires are punctured: Turn the power switch off then turn it to ON. Check if the tire pressure warning light comes on or blinks.

- ▶ If the tire pressure warning light blinks for approximately 1 minute then stays on

There may be a malfunction in the tire pressure warning system. Have the vehicle inspected by any authorized Toyota retailer or Toyota authorized repairer, or any reliable repairer immediately.

- ▶ If the tire pressure warning light comes on

- 1 After the temperature of the tires has lowered sufficiently, check the inflation pressure of each tire and adjust them to the specified level.
- 2 If the warning light does not turn off even after several minutes have elapsed, check that the inflation pressure of each tire is at the specified level and perform initialization. (→P.337)

■ The tire pressure warning light may come on due to natural causes

The tire pressure warning light may come on due to natural causes such as natural air leaks and tire inflation pressure changes caused by temperature. In this case, adjusting the tire inflation pressure will turn off the warning light (after a few minutes).

■ **When a tire is replaced with a spare tire**

Vehicles with a compact spare tire: The compact spare tire is not equipped with a tire pressure warning valve and transmitter. If a tire goes flat, the tire pressure warning light will not turn off even though the flat tire has been replaced with the spare tire. Replace the spare tire with the repaired tire and adjust the tire inflation pressure. The tire pressure warning light will go off after a few minutes.

Vehicles with a full-size spare tire: The spare tire is also equipped with a tire pressure warning valve and transmitter. The tire pressure warning light will turn on if the tire inflation pressure of the spare tire is low. If a tire goes flat, the tire pressure warning light will not turn off even though the flat tire has been replaced with the spare tire. Replace the spare tire with the repaired tire and adjust the tire inflation pressure. The tire pressure warning light will go off after a few minutes.

■ **Conditions that the tire pressure warning system may not function properly**

→P.336



WARNING

■ **If both the ABS and the brake system warning lights remain on**

Stop your vehicle in a safe place immediately and contact any authorized Toyota retailer or Toyota authorized repairer, or any reliable repairer. The vehicle will become extremely unstable during braking, and the ABS system may fail, which could cause an accident resulting in death or serious injury.

■ **When the electric power steering system warning light comes on**

When the light comes on yellow, the assist to the power steering is restricted. When the light comes on red, the assist to the power steering is lost and handling operations of the steering wheel become extremely heavy.

When steering wheel operations are heavier than usual, grip the steering wheel firmly and operate it using more force than usual.

■ **If the tire pressure warning light comes on**

Be sure to observe the following precautions.

Failure to do so could cause a loss of vehicle control and result in death or serious injury.

- Stop your vehicle in a safe place as soon as possible. Adjust the tire inflation pressure immediately.

- Vehicles with a compact spare tire and full-size spare tire: If the tire pressure warning light comes on even after tire inflation pressure adjustment, it is probable that you have a flat tire. Check the tires. If a tire is flat, change it with the spare tire and have the flat tire repaired by the nearest any authorized Toyota retailer or Toyota authorized repairer, or any reliable repairer.

- Vehicles with emergency tire puncture repair kit: If the tire pressure warning light comes on even after tire inflation pressure adjustment, it is probable that you have a flat tire. Check the tires. If a tire is flat, repair the flat tire by using emergency tire puncture repair kit.

- Avoid abrupt maneuvering and braking.
If the vehicle tires deteriorate, you could lose control of the steering wheel or the brakes.

**WARNING****■ If a blowout or sudden air leakage should occur**

The tire pressure warning system may not activate immediately.

**NOTICE****■ To ensure the tire pressure warning system operates properly**

Do not install tires with different specifications or makers, as the tire pressure warning system may not operate properly.

If a warning message is displayed

The multi-information display shows warnings for system malfunctions and incorrectly performed operations, and messages that indicate a need for maintenance. When a message is displayed, perform the appropriate corrective action for the message.

If a warning message is displayed again after the appropriate actions have been performed, contact any authorized Toyota retailer or Toyota authorized repairer, or any reliable repairer.

Additionally, if a warning light comes on or flashes at the same time that a warning message is displayed, take the appropriate corrective action for the warning light. (→P.374)

■ Warning messages

The warning messages explained below may differ from the actual messages according to operation conditions and vehicle specifications.

■ Warning buzzer

A buzzer may sound when a message is displayed.

The buzzer may not be audible if the vehicle is in a noisy location or if the audio system volume is high.

■ If “Engine Oil Level Low Add or Replace” is displayed

The engine oil level is low. Check the

level of the engine oil, and add if necessary.

This message may appear if the vehicle is stopped on a slope. Move the vehicle to a level surface and check to see if the message disappears.

■ **If “Hybrid System Stopped Steering Power Low” is displayed**

This message is displayed if the hybrid system is stopped while driving.

When steering wheel operations are heavier than usual, grip the steering wheel firmly and operate it using more force than usual.

■ **If “Hybrid System Overheated Output Power Reduced” is displayed**

This message may be displayed when driving under severe operating conditions. (For example, when driving up a long steep hill.)

Handling method: →P.414

■ **If “Traction Battery Needs to be Protected Refrain from the Use of N Position” is displayed**

This message may be displayed when the shift lever is in N.

As the hybrid battery (traction battery) cannot be charged when the shift lever is in N, shift the shift lever to P when the vehicle is stopped.

■ **If “Traction Battery Needs to be Protected Shift into P to Restart” is displayed**

This message is displayed when the hybrid battery (traction battery) charge has become extremely low because the shift lever has been left in N for a certain amount of time.

When operating the vehicle, shift to P and restart the hybrid system.

■ **If “Shift to P Before Exiting Vehicle” is shown**

Message is displayed when the driver’s door is opened without turning the power switch to OFF with the shift lever in any position other than P. Shift the shift lever to P.

■ **If “Shift is in N Release Accelerator Before Shifting” is displayed**

The accelerator pedal has been depressed when the shift lever is in N.

Release the accelerator pedal and shift the shift lever to D or R.

■ **If “Press Brake when Vehicle is Stopped Hybrid System may Overheat” is displayed**

The message may be displayed when the accelerator pedal is depressed to hold the vehicle while the vehicle is stopped on an incline, etc. The hybrid system may overheat. Release the accelerator pedal and depress the brake pedal.

■ **If “Auto Power OFF to Conserve Battery” is displayed**

Power was cut off due to the automatic power off function. Next time when starting the hybrid system, operate the hybrid system for approximately 5 minutes to recharge the 12-volt battery.

■ **If “Headlight System Malfunction Visit Your Dealer” is displayed**

The following systems may be malfunctioning. Have the vehicle inspected by any authorized Toyota retailer or Toyota authorized repairer, or any reliable repairer immediately.

- The LED headlight system (if equipped)
- Automatic High Beam (if equipped)

■ **If a message that indicates the malfunction of front camera is displayed**

The following systems may be suspended until the problem shown in the message is resolved. (→P.207, 374)

- PCS (Pre-Collision system) (if equipped)
- LTA (Lane Tracing Assist) (if equipped)
- Automatic High Beam (if equipped)
- RSA (Road Sign Assist) (if equipped)
- Dynamic radar cruise control with full-

speed range (if equipped)

■ **If a message that indicates the malfunction of radar sensor is displayed**

The following systems may be suspended until the problem shown in the message is resolved. (→P.207, 374)

- PCS (Pre-Collision system) (if equipped)
- LTA (Lane Tracing Assist) (if equipped)
- Dynamic radar cruise control with full-speed range (if equipped)

■ **If “Oil Maintenance Required Soon” is displayed**

Indicates that the engine oil should be scheduled to be changed.

Check the engine oil and change it if necessary.

After changing the engine oil, make sure to reset the message. (→P.327)

■ **If “Oil Maintenance Required Visit Your Dealer” is displayed**

Indicates that the engine oil should be changed.

Check and change the engine oil, and oil filter by any authorized Toyota retailer or Toyota authorized repairer, or any reliable repairer. After changing the engine oil, make sure to reset the message. (→P.327)

■ **If “Radar Cruise Control Unavailable See Owner’s Manual” is displayed (if equipped)**

The dynamic radar cruise control with full-speed range system is suspended temporarily or until the problem shown in the message is resolved. (causes and coping methods: →P.207)

■ **If “Radar Cruise Control Unavailable” is displayed (if equipped)**

The dynamic radar cruise control with full-speed range system cannot be used temporarily. Use the system when it becomes available again.

■ **If a message that indicates the need for visiting your Toyota dealer is displayed**

The system or part shown on the multi-information display is malfunctioning. Have the vehicle inspected by any authorized Toyota retailer or Toyota authorized repairer, or any reliable repairer immediately.

■ **If a message that indicates the need for referring to Owner’s Manual is displayed**

- If “Engine Coolant Temp High” is displayed, follow the instructions accordingly. (→P.414)
- If “Exhaust Filter Full” is displayed, follow the instructions accordingly. (→P.276)
- If any of the following messages are displayed on the multi-information display, it may indicate a malfunction. Have the vehicle inspected by any authorized Toyota retailer or Toyota authorized repairer, or any reliable repairer immediately.
 - “Smart Entry & Start System Malfunction”
 - “Hybrid System Malfunction”
 - “Check Engine”
 - “Hybrid Battery System Malfunction”
 - “Accelerator System Malfunction”
- If any of the following messages are displayed on the multi-information display, it may indicate a malfunction. Immediately stop the vehicle and contact any authorized Toyota retailer or Toyota authorized repairer, or any reliable repairer.
 - “Braking Power Low”
 - “12-Volt Battery Charging System Malfunction”
 - “Oil Pressure Low”
- If any of the following messages are shown on the multi-information display, the vehicle may have run out of fuel. Stop the vehicle in a safe place and, if the fuel level is low, refuel the vehicle. (→P.80)
 - “Hybrid System Stopped”
 - “Engine Stopped”

- If “Low Auxiliary Battery” is shown,
 - When the display goes off after several seconds (displays for about 6 seconds): Maintain the hybrid system operation for more than 15 minutes and charge the 12-volt battery.
 - When the display does not go off: Start up the hybrid system using the procedures: →P.409
- If “Maintenance Required for Traction Battery Cooling Parts See Owner’s Manual” is shown, the filters may be clogged, the air intake vents may be blocked, or there may be a gap in the duct. Therefore, perform the following correction procedure.
 - If the air intake vents and filters of the hybrid battery (traction battery) are dirty, perform the procedure on P.348 to clean them.
 - If the warning message is shown when the air intake vents and filters of the hybrid battery (traction battery) are not dirty, have the vehicle inspected by any authorized Toyota retailer or Toyota authorized repairer, or any reliable repairer immediately.

If you have a flat tire (vehicles with an emergency tire puncture repair kit)

Your vehicle is not equipped with a spare tire, but instead is equipped with an emergency tire puncture repair kit.

A puncture caused by a nail or screw passing through the tire tread can be repaired temporarily using the emergency tire puncture repair kit. (The kit contains a bottle of sealant.

The sealant can be used only once to temporarily repair one tire without removing the nail or screw from the tire.)

Depending on the damage, this kit cannot be used to repair the tire. (→P.387)

After temporarily repairing the tire with the kit, have the tire repaired or replaced by any authorized Toyota retailer or Toyota authorized repairer, or any reliable repairer. Repairs conducted using the emergency tire puncture repair kit are only a temporary measure. Have the tire repaired and replaced as soon as possible.

**WARNING****■ If you have a flat tire**

Do not continue driving with a flat tire. Driving even a short distance with a flat tire can damage the tire and the wheel beyond repair, which could result in an accident.

Before repairing the tire

- Stop the vehicle in a safe place on a hard, flat surface.
- Set the parking brake.
- Shift the shift lever to P.
- Stop the hybrid system.
- Turn on the emergency flashers. (→P.366)
- Check the degree of the tire damage.

Do not remove the nail or screw from the tire. Removing the object may widen the opening and make emergency repair with the repair kit impossible.

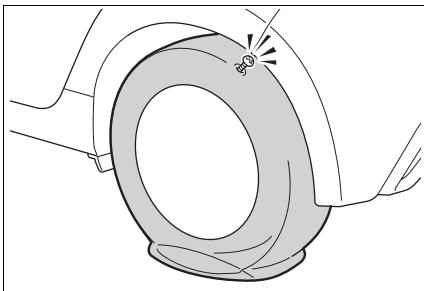
**■ A flat tire that cannot be repaired with the emergency tire puncture repair kit**

In the following cases, the tire cannot be repaired with the emergency tire puncture repair kit. Contact any authorized

Toyota retailer or Toyota authorized repairer, or any reliable repairer.

- When the tire is damaged due to driving without sufficient air pressure
- When there are any cracks or damage at any location on the tire, such as on the side wall, except the tread
- When the tire is visibly separated from the wheel
- When the cut or damage to the tread is 4 mm (0.16 in.) long or more
- When the wheel is damaged
- When two or more tires have been punctured
- When more than 2 sharp objects such as nails or screws have passed through the tread on a single tire
- When the sealant has expired

Location of the emergency tire puncture repair kit and tools

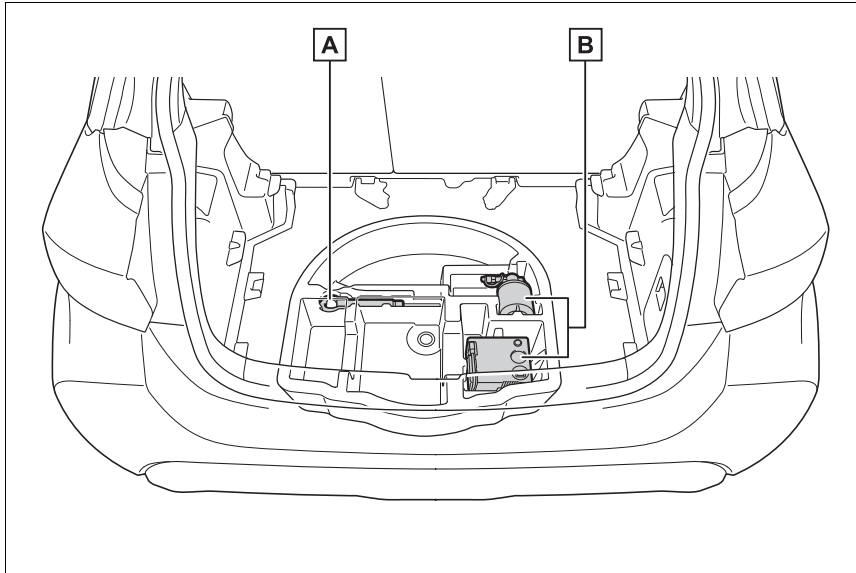

A Towing eyelet

B Emergency tire puncture repair kit

Emergency tire puncture repair kit components

► Bottle

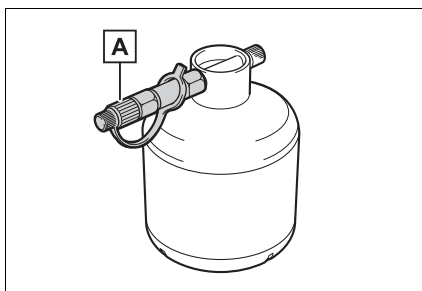

A Nozzle

► Compressor

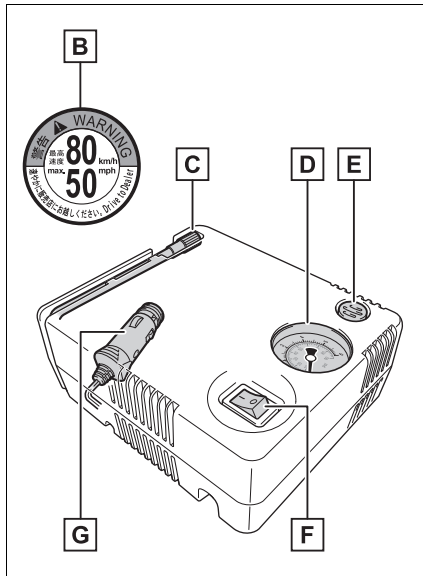

- B** Sticker
- C** Hose
- D** Air pressure gauge
- E** Pressure release button
- F** Compressor switch
- G** Power plug

■ **Note for checking the emergency tire puncture repair kit**

Check the sealant expiry date occasionally.

The expiry date is shown on the bottle. Do not use sealant whose expiry date has already passed. Otherwise, repairs conducted using the emergency tire puncture repair kit may not be performed properly.

■ **Emergency tire puncture repair kit**

- The emergency tire puncture repair kit is for filling the car tire with air.

- The sealant has a limited life span. The expiry date is marked on the bottle. The sealant should be replaced before the expiry date. Contact any authorized Toyota retailer or Toyota authorized repairer, or any reliable repairer for replacement.
- The sealant stored in the emergency tire puncture repair kit can be used only once to temporarily repair a single tire. If the sealant has been used and needs to be replaced, purchase a new bottle at any authorized Toyota retailer or Toyota authorized repairer, or any reliable repairer. The compressor is reusable.
- The sealant can be used when the outside temperature is from -30°C (-22°F) to 60°C (140°F).
- The kit is exclusively designed for size and type of tires originally installed on your vehicle. Do not use it for tires that a different size than the original ones, or for any other purposes.
- If the sealant gets on your clothes, it may stain.
- If the sealant adheres to a wheel or the surface of the vehicle body, the stain may not be removable if it is not cleaned at once. Immediately wipe away the sealant with a wet cloth.
- During operation of the repair kit, a loud operation noise is produced. This does not indicate a malfunction.
- Do not use to check or to adjust the tire pressure.

WARNING

■ **Caution while driving**

- Store the repair kit in the luggage compartment. Injuries may result in the event of an accident or sudden braking.

⚠ WARNING

- The repair kit is exclusively only for your vehicle. Do not use repair kit on other vehicles, which could lead to an accident causing death or serious injury.
 - Do not use repair kit for tires that are different size than the original ones, or for any other purpose. If the tires have not been completely repaired, it could lead to an accident causing death or serious injury.
- **Precautions for use of the sealant**
- Ingesting the sealant is hazardous to your health. If you ingest sealant, consume as much water as possible, and then immediately consult a doctor.
 - If sealant gets in eyes or adheres to skin, immediately wash it off with water. If discomfort persists, consult a doctor.

Taking out the emergency tire puncture repair kit

- 1 Open the deck board and floor cover. (→P.299)
- 2 Take out the emergency tire puncture repair kit. (→P.388)

Emergency repair method

- 1 Attach the sticker provided with the tire puncture repair kit to a

position easily seen from the driver's seat.



- 2 Remove the valve cap from the valve of the punctured tire.

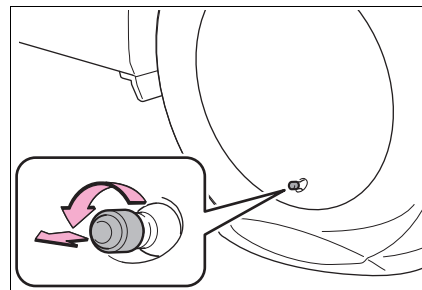

- 3 Remove the cap from the nozzle.

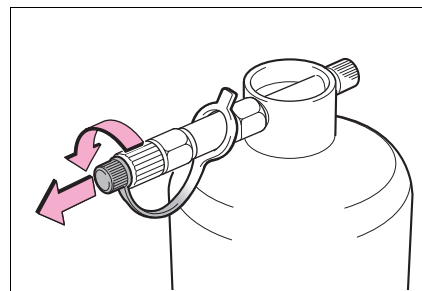

- 4 Connect the nozzle to the valve.

Screw the end of the nozzle clockwise as far as possible. The bottle should hang vertically without contacting the ground. If the bottle does not hang vertically, move the vehicle so that the tire

valve is located properly.

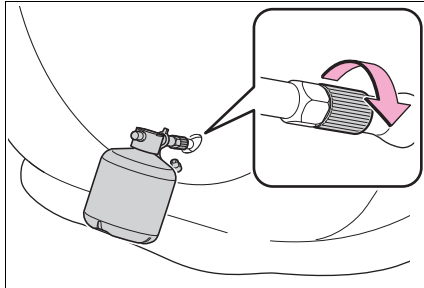

5 Remove the cap from the bottle.

far as possible.

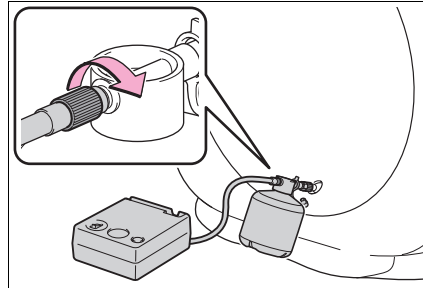

8 Make sure that the compressor switch is  (off).

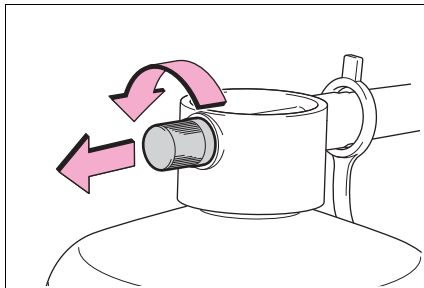

6 Pull the hose out from the compressor.

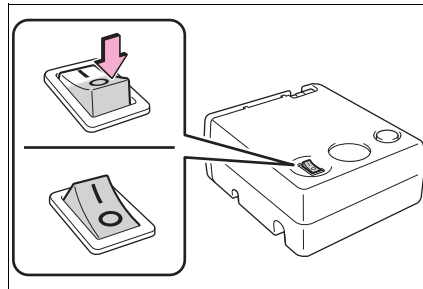

9 Remove the power plug from the compressor.

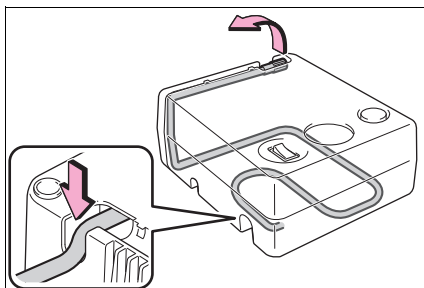

7 Connect the bottle to the compressor.

Screw the end of the hose clockwise as

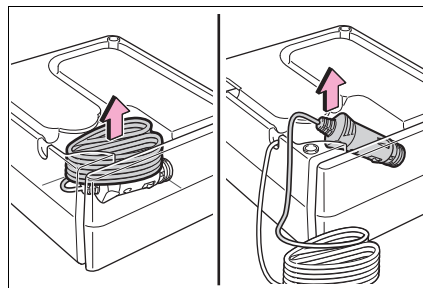

7

When trouble arises

392 7-2. Steps to take in an emergency

10 Connect the power plug to the power outlet socket. (→P.303)

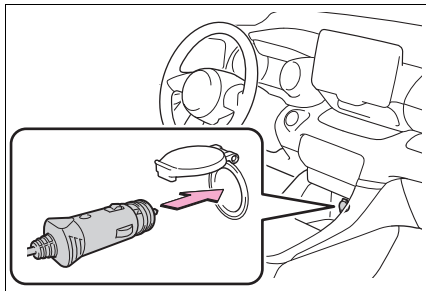

11 Check the specified tire inflation pressure.

Tire inflation pressure is specified on the label on the driver's side door frame as shown. (→P.427)

► Left-hand drive vehicles

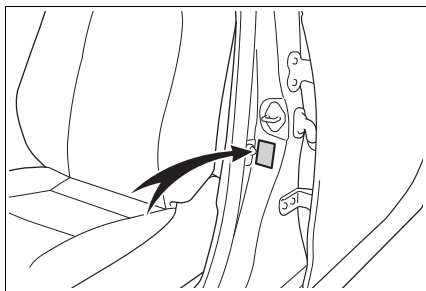

► Right-hand drive vehicles

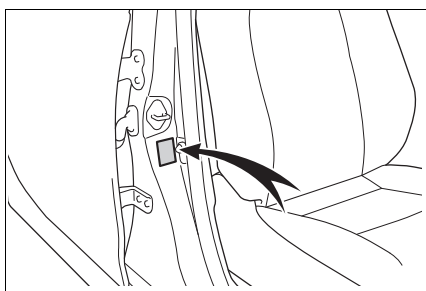

12 Start the hybrid system.

13 To inject the sealant and inflate the tire, turn the compressor switch to **I** (on).

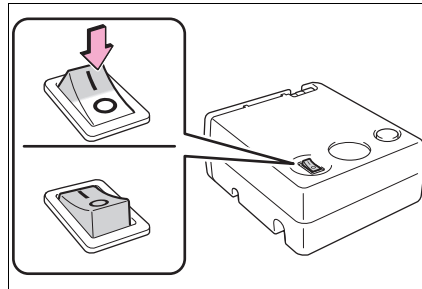

14 Inflate the tire until the specified air pressure is reached.

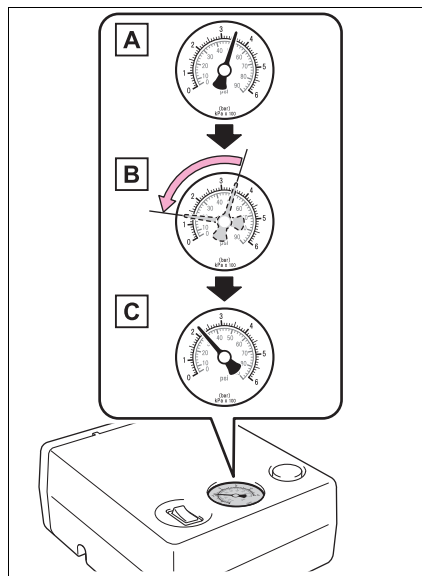

A The sealant will be injected and the pressure will surge and then gradually decrease.

B The air pressure gauge will display the actual tire inflation pressure about 1 minute (5 minutes

at low temperature) after the switch is turned **I** (on).

C Inflate the tire to the specified air pressure.

- If the tire inflation pressure is still lower than the specified point after inflation for 35 minutes with the switch at **I** (on), the tire is too damaged to be repaired. Turn the compressor switch to **O** (off) and contact any authorized Toyota retailer or Toyota authorized repairer, or any reliable repairer.
- If the tire inflation pressure exceeds the specified air pressure, let out some air to adjust the tire inflation pressure. (→P.395, 427)

15 Turn the compressor switch to **O** (off).

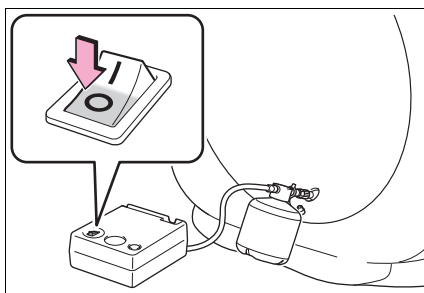

16 Disconnect the nozzle from the valve on the tire and then pull out the power plug from the power outlet socket or cigarette lighter.

Some sealant may leak when the nozzle is removed.

17 Press the button to release pressure from the bottle.

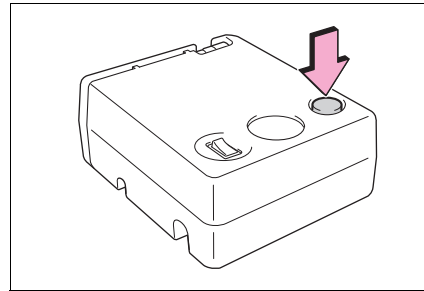

18 Attach the cap to the nozzle.

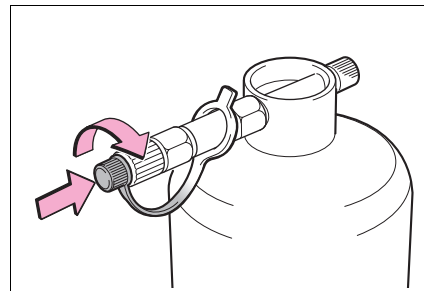

19 Install the valve cap onto the valve of the emergency repaired tire.

20 Disconnect the hose from the bottle and attach the cap to the bottle.

Place the bottle in the original bag and zip it.

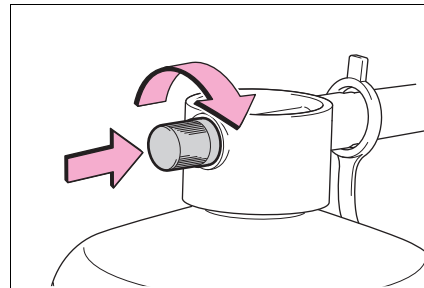

394 7-2. Steps to take in an emergency

21 Temporarily store the bottle and compressor in the luggage compartment.

22 To spread the liquid sealant evenly within the tire, immediately drive safely for about 5 km (3 miles) below 80 km/h (50 mph).

23 After driving for about 5 km (3 miles), stop your vehicle in a safe place on a hard, flat surface and connect the compressor.

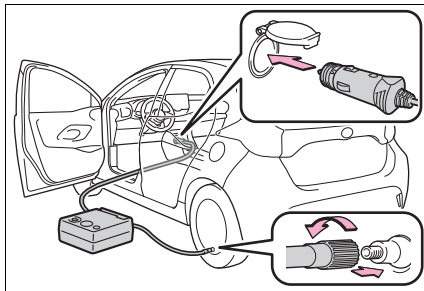

24 Check the tire inflation pressure.

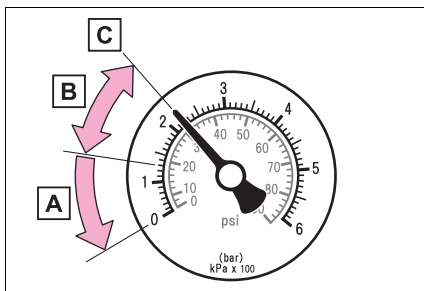

A If the tire inflation pressure is under 130 kPa (1.3 kgf/cm² or bar, 19 psi): The puncture cannot be repaired. Contact any authorized Toyota retailer or Toyota authorized repairer, or

any reliable repairer.

B If the tire inflation pressure is 130 kPa (1.3 kgf/cm² or bar, 19 psi) or higher, but less than the specified air pressure: Proceed to step **25**.

C If the tire inflation pressure is the specified air pressure (→P.427): Proceed to step **26**.

25 Turn the compressor switch to **I** (on) to inflate the tire until the specified air pressure is reached. Drive for about 5 km (3 miles) and then perform step **24**.

26 Store the bottle in the luggage compartment while it is connected to the compressor.

27 Taking precautions to avoid sudden braking, sudden acceleration and sharp turns, drive carefully at under 80 km/h (50 mph) to the nearest any authorized Toyota retailer or Toyota authorized repairer, or any reliable repairer for tire repair or replacement.

28 For repair and replacement of a tire or disposal of the tire puncture repair kit, contact any authorized Toyota retailer or Toyota authorized repairer, or any reliable repairer.

When having the tire repaired or

replaced, make sure to tell any authorized Toyota retailer or Toyota authorized repairer, or any reliable repairer that the sealant is injected.

■ **If the tire is inflated to more than the specified air pressure**

- 1 Press the button to let some air out.

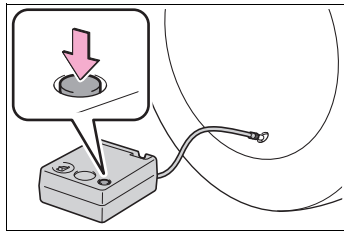

- 2 Check that the air pressure indicator shows the specified air pressure. If the air pressure is under the designated pressure, turn the compressor switch **I** (on) again and repeat the inflation procedure until the specified air pressure is reached.

■ **The valve of a tire that has been repaired**

After a tire is repaired with the emergency tire puncture repair kit, the valve should be replaced.

■ **After a tire is repaired with the emergency tire puncture repair kit**

- The tire pressure warning valve and transmitter should be replaced.
- Even if the tire inflation pressure is at the recommended level, the tire pressure warning light may come on/flash.

! WARNING

■ **Do not drive the vehicle with a flat tire**

Do not continue driving with a flat tire. Driving even a short distance with a flat tire can damage the tire and the wheel beyond repair.

Driving with a flat tire may cause a circumferential groove on the side wall. In such a case, the tire may explode when using a repair kit.

■ **When fixing the flat tire**

- Stop your vehicle in a safe and flat area.
- Do not touch the wheels or the area around the brakes immediately after the vehicle has been driven. After the vehicle has been driven, the wheels and the area around the brakes may be extremely hot. Touching these areas with hands, feet or other body parts may result in burns.
- Connect the valve and hose securely with the tire installed on the vehicle. If the hose is not properly connected to the valve, air leakage may occur as sealant may be sprayed out.
- If the hose comes off the valve while inflating the tire, there is a risk that the hose will move abruptly due to air pressure.
- After inflation of the tire has completed, the sealant may splatter when the hose is disconnected or some air is let out of the tire.
- Follow the operation procedure to repair the tire. If the procedures not followed, the sealant may spray out.

**WARNING**

- Keep back from the tire while it is being repaired, as there is a chance of it bursting while the repair operation is being performed. If you notice any cracks or deformation of the tire, turn  (off) the compressor switch and stop the repair operation immediately.
- The repair kit may overheat if operated for a long period of time. Do not operate the repair kit continuously for more than 40 minutes.
- Parts of the repair kit become hot during operation. Be careful when handling the repair kit during and after operation. Do not touch the metal part around the connecting area between the bottle and compressor. It will be extremely hot.
- Do not attach the vehicle speed warning sticker to an area other than the one indicated. If the sticker is attached to an area where an SRS airbag is located, such as the pad of the steering wheel, it may prevent the SRS airbag from operating properly.
- To avoid risk of burst or severe leakage, do not drop or damage the bottle. Visually inspect the bottle before use. Do not use a bottle with shock, crack, scratch, leakage or any other damage. In such case, immediately replace.

■ Driving to spread the liquid sealant evenly

Observe the following precautions to reduce the risk of accidents. Failing to do so may result in a loss of vehicle control and cause death or serious injury.

- Drive the vehicle carefully at a low speed. Be especially careful when turning and cornering.

- If the vehicle does not drive straight or you feel a pull through the steering wheel, stop the vehicle and check the following.

- Tire condition. The tire may have separated from the wheel.
- Tire inflation pressure. If the tire inflation pressure is 130 kPa (1.3 kgf/cm² or bar, 19 psi) or less, the tire may be severely damaged.

**NOTICE****■ When performing an emergency repair**

- A tire should only be repaired with the emergency tire puncture repair kit if the damage is caused by a sharp object such as nail or screw passing through the tire tread. Do not remove the sharp object from the tire. Removing the object may widen the opening and disable emergency repair with the repair kit.
- The repair kit is not waterproof. Make sure that the repair kit is not exposed to water, such as when it is being used in the rain.
- Do not put the repair kit directly onto dusty ground such as sand at the side of the road. If the repair kit vacuums up dust etc., a malfunction may occur.
- Do not turn the bottle upside down when using it, as doing so may cause damage to the compressor.

■ Precautions for the emergency tire puncture repair kit

- The repair kit power source should be 12 V DC suitable for vehicle use. Do not connect the repair kit to any other source.

**NOTICE**

- If fuel splatters on the repair kit, the repair kit may deteriorate. Take care not to allow fuel to contact it.
- Place the repair kit in a storage to prevent it from being exposed to dirt or water.
- Store the repair kit in the luggage compartment out of reach of children.
- Do not disassemble or modify the repair kit. Do not subject parts such as the air pressure indicator to impacts. This may cause a malfunction.

■ **To avoid damage to the tire pressure warning valves and transmitters**

When a tire is repaired with liquid sealants, the tire pressure warning valve and transmitter may not operate properly. If a liquid sealant is used, contact any authorized Toyota retailer or Toyota authorized repairer, or any reliable repairer or other qualified service shop as soon as possible. After use of liquid sealant, make sure to replace the tire pressure warning valve and transmitter when repairing or replacing the tire. (→P.336)

If you have a flat tire (vehicles with a spare tire)

Your vehicle is equipped with a spare tire. The flat tire can be replaced with the spare tire.

For details about tires: →P.332

**WARNING**

■ **If you have a flat tire**

Do not continue driving with a flat tire. Driving even a short distance with a flat tire can damage the tire and the wheel beyond repair, which could result in an accident.

Before jacking up the vehicle

- Stop the vehicle in a safe place on a hard, flat surface.
- Set the parking brake.
- Shift the shift lever to P.
- Stop the hybrid system.
- Turn on the emergency flashers. (→P.366)

Location of the spare tire, jack and tools

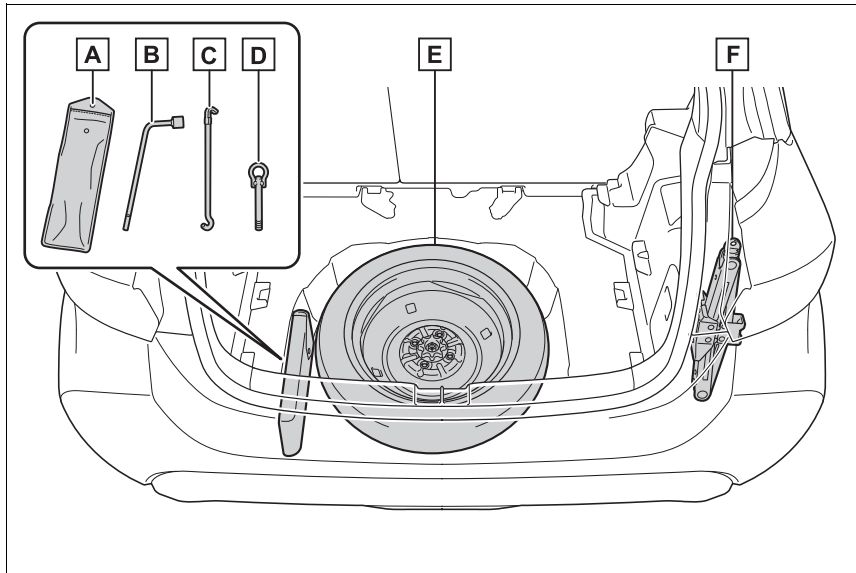

A Tool bag

B Wheel nut wrench

C Jack handle

D Towing eyelet

E Spare tire

F Jack

⚠ WARNING

■ Using the tire jack

Observe the following precautions. Improper use of the tire jack may cause the vehicle to suddenly fall off the jack, leading to death or serious injury.

- Do not use the tire jack for any purpose other than replacing tires or installing and removing tire chains.

- Only use the tire jack that comes with this vehicle for replacing a flat tire. Do not use it on other vehicles, and do not use other tire jacks for replacing tires on this vehicle.

⚠ WARNING

- Put the jack properly in its jack point.

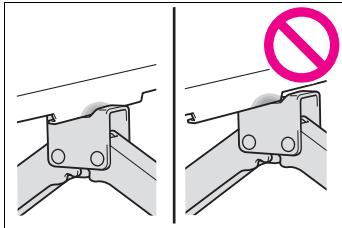

- Do not put any part of your body under the vehicle while it is supported by the jack.
- Do not start the hybrid system or drive the vehicle while the vehicle is supported by the jack.
- Do not raise the vehicle while someone is inside.
- When raising the vehicle, do not put an object on or under the jack.
- Do not raise the vehicle to a height greater than that required to replace the tire.
- Use a jack stand if it is necessary to get under the vehicle.
- When lowering the vehicle, make sure that there is no-one near the vehicle. If there are people nearby, warn them vocally before lowering.

Taking out the jack

- 1 Remove the deck board and floor cover. (→P.299)

- 2 Remove the cover.

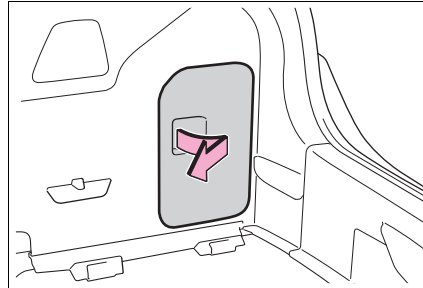

- 3 Unhook the rubber band and remove the jack.

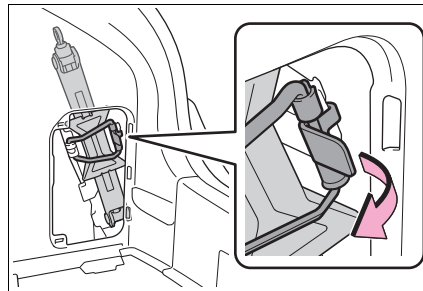
**Taking out the spare tire**

- 1 Remove the deck board and floor cover. (→P.299)
- 2 Remove the tool bag.

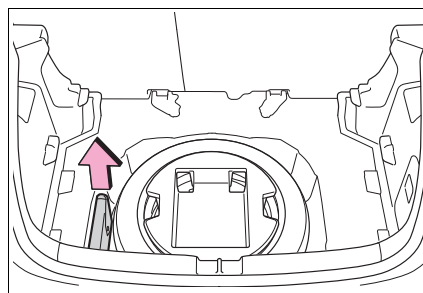

- 3 Remove the spare wheel cushion (if equipped).

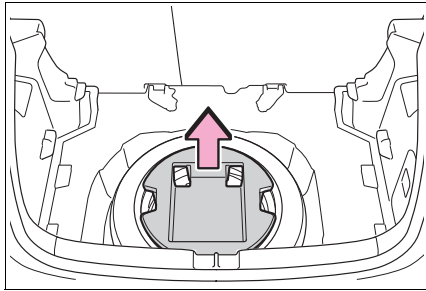

- 4 Loosen the center fastener that secures the spare tire.

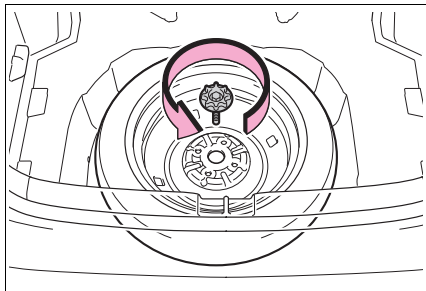

⚠ WARNING

■ **When storing the spare tire**

Be careful not get fingers caught or other body parts between the spare tire and the body of the vehicle.

Replacing a flat tire

- 1 Chock the tires.

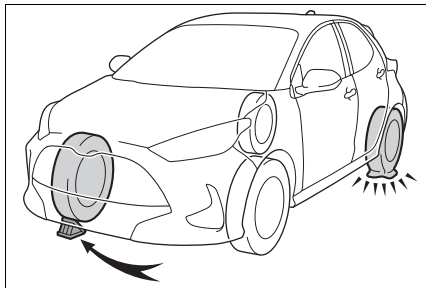

Flat tire	Wheel chock positions
Front left-hand side	Behind the rear right-hand side tire
Front right-hand side	Behind the rear left-hand side tire
Rear left-hand side	In front of the front right-hand side tire
Rear right-hand side	In front of the front left-hand side tire

- 2 Vehicles with a steel wheel:
Remove the wheel ornament using the wrench.

Insert the wrench into the notch **A** on the wheel cap.

To protect the wheel ornament, place a rag between the wrench and the wheel ornament.

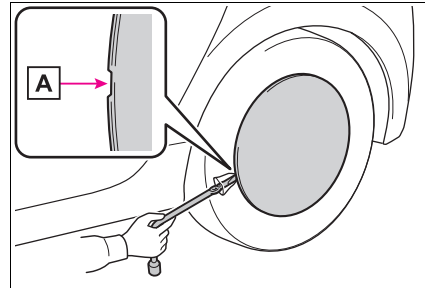

- 3 Slightly loosen the wheel nuts (one turn).

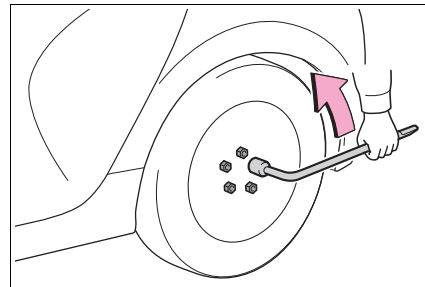

- 4 Turn the tire jack portion **A** by hand until the center of the recessed portion of the jack is in contact with the center of the jack point.

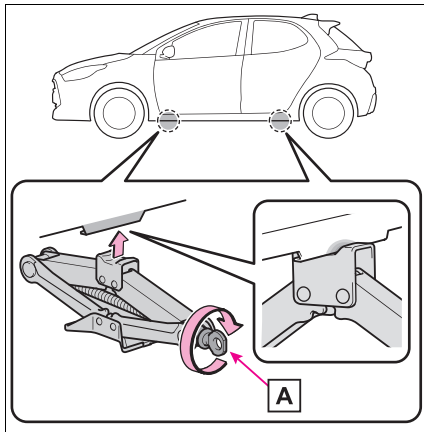

- 5 Assemble the jack handle extension.

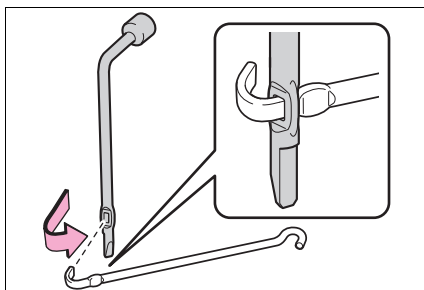

- 6 Raise the vehicle until the tire is slightly raised off the ground.

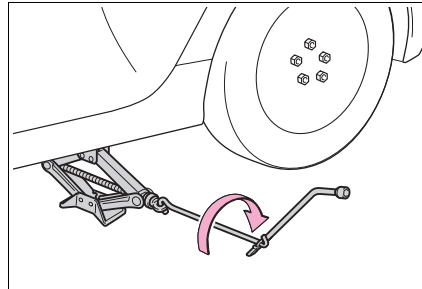

- 7 Remove all the wheel nuts and the tire.

When resting the tire on the ground, place the tire so that the wheel design faces up to avoid scratching the wheel surface.

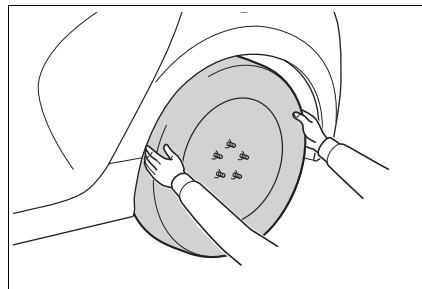

WARNING

Replacing a flat tire

- Do not touch the disc wheels or the area around the brakes immediately after the vehicle has been driven. After the vehicle has been driven the disc wheels and the area around the brakes will be extremely hot. Touching these areas with hands, feet or other body parts while changing a tire, etc. may result in burns.
- Failure to follow these precautions could cause the wheel nuts to loosen and the tire to fall off, resulting in death or serious injury.

⚠ WARNING

- Have the wheel nuts tightened with a torque wrench to 103 N•m (10.5 kgf•m, 76 ft•lbf) as soon as possible after changing wheels.
- Do not attach a heavily damaged wheel ornament, as it may fly off the wheel while the vehicle is moving.
- When installing a tire, only use wheel nuts that have been specifically designed for that wheel.
- If there are any cracks or deformations in the bolt screws, nut threads or bolt holes of the wheel, have the vehicle inspected by any authorized Toyota retailer or Toyota authorized repairer, or any reliable repairer.
- When installing the wheel nuts, be sure to install them with the tapered ends facing inward. (→P.402)

Installing the spare tire

- 1 Remove any dirt or foreign matter from the wheel contact surface.

If foreign matter is on the wheel contact surface, the wheel nuts may loosen while the vehicle is in motion, causing the tire to come off.

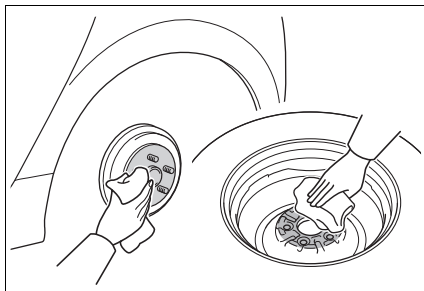

- 2 Install the tire and loosely tighten each wheel nut by hand

by approximately the same amount.

When replacing a steel wheel with a steel wheel (including a compact spare tire), tighten the wheel nuts until the tapered portion **A** comes into loose contact with the disc wheel seat **B**.

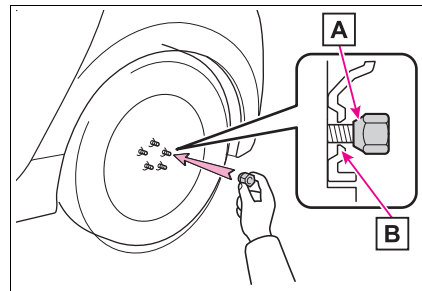

When replacing an aluminum wheel with a steel wheel (including a compact spare tire), tighten the wheel nuts until the tapered portion **A** comes into loose contact with the disc wheel seat **B**.

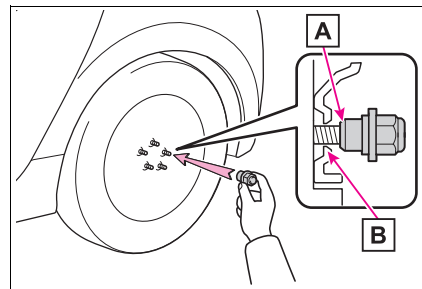

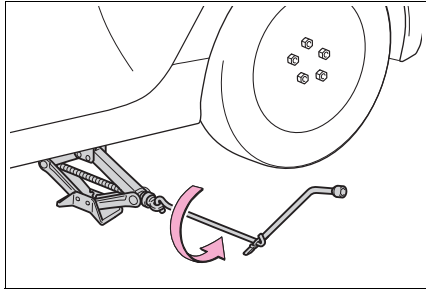
3 Lower the vehicle.**4** Firmly tighten each wheel nut two or three times in the order shown in the illustration.

Tightening torque:
103 N•m (10.5 kgf•m, 76 ft•lbf)

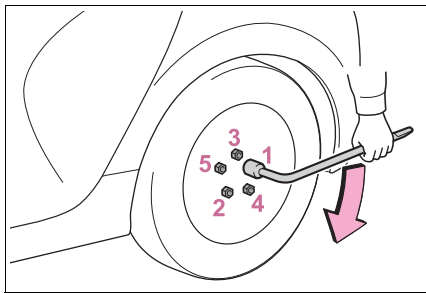
**5** Stow the flat tire, tire jack and all tools.**■ The full-size spare tire (if equipped)**

- The full-size spare tire has a "Temporary use only" label on the outer surface of the wheel. Use the full-size spare tire temporarily, and only in an emergency.
- Make sure to check the tire inflation pressure of the full-size spare tire. (→P.427)

■ The compact spare tire (if equipped)

- The compact spare tire is identified by the label "TEMPORARY USE ONLY" on the tire sidewall. Use the compact spare tire temporarily, and only in an

emergency.

- Make sure to check the tire inflation pressure of the compact spare tire. (→P.427)

■ When the compact spare tire (if equipped) is equipped

The vehicle becomes lower when driving with the compact spare tire compared to when driving with standard tires.

■ When using the compact spare tire (if equipped)

As the compact spare tire is not equipped with a tire pressure warning valve and transmitter, low inflation pressure of the compact spare tire will not be indicated by the tire pressure warning system. Also, if you replace the compact spare tire after the tire pressure warning light comes on, the light remains on.

■ If you have a flat front tire on a road covered with snow or ice (vehicles with a compact spare tire)

Install the compact spare tire on one of the rear wheels of the vehicle. Perform the following steps and fit tire chains to the front tires:

- 1 Replace a rear tire with the compact spare tire.
- 2 Replace the flat front tire with the tire removed from the rear of the vehicle.
- 3 Fit tire chains to the front tires.

■ When reinstalling the wheel ornament (steel wheels except compact spare tire)

Align the cutout of the wheel ornament with the valve stem as shown in the illustration.

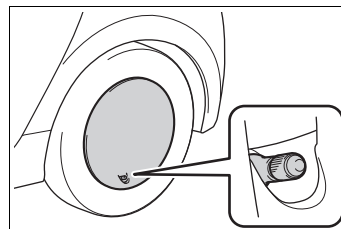



WARNING

■ **When using the full-size spare tire (if equipped)**

- Replace the full-size spare tire with a standard tire as soon as possible.
- Avoid sudden acceleration, abrupt steering, sudden braking and shifting operations that cause sudden engine braking.

■ **When using the compact spare tire (if equipped)**

- Remember that the compact spare tire provided is specifically designed for use with your vehicle. Do not use your compact spare tire on another vehicle.
- Do not use more than one compact spare tires simultaneously.
- Replace the compact spare tire with a standard tire as soon as possible.
- Avoid sudden acceleration, abrupt steering, sudden braking and shifting operations that cause sudden engine braking.

■ **When the compact spare tire (if equipped) is attached**

The vehicle speed may not be correctly detected, and the following systems may not operate correctly:

- ABS & Brake assist
- VSC
- TRC
- Automatic High Beam (if equipped)
- Dynamic radar cruise control with full-speed range (if equipped)
- EPS
- PCS (Pre-Collision System) (if equipped)
- LTA (Lane Tracing Assist) (if equipped)

- Tire pressure warning system
- Toyota parking assist-sensor (if equipped)
- PKSB (Parking Support Brake) (if equipped)
- BSM (Blind Spot Monitor) (if equipped)
- Rear view monitor system (if equipped)
- Navigation system (if equipped)

■ **Speed limit when using the compact spare tire (if equipped)**

Do not drive at speeds in excess of 80 km/h (50 mph) when a compact spare tire is installed on the vehicle.

The compact spare tire is not designed for driving at high speeds. Failure to observe this precaution may lead to an accident causing death or serious injury.

■ **After using the tools and jack**

Before driving, make sure all the tools and jack are securely in place in their storage location to reduce the possibility of personal injury during a collision or sudden braking.



NOTICE

■ **Be careful when driving over bumps with the compact spare tire (if equipped) installed on the vehicle.**

The vehicle becomes lower when driving with the compact spare tire compared to when driving with standard tires. Be careful when driving over uneven road surfaces.

**NOTICE****■ Driving with tire chains and the compact spare tire (if equipped)**

Do not fit tire chains to the compact spare tire. Tire chains may damage the vehicle body and adversely affect driving performance.

■ When replacing the tires

When removing or fitting the wheels, tires or the tire pressure warning valve and transmitter, contact any authorized Toyota retailer or Toyota authorized repairer, or any reliable repairer as the tire pressure warning valve and transmitter may be damaged if not handled correctly.

■ To avoid damage to the tire pressure warning valves and transmitters (except for compact spare)

When a tire is repaired with liquid sealants, the tire pressure warning valve and transmitter may not operate properly. If a liquid sealant is used, contact any authorized Toyota retailer or Toyota authorized repairer, or any reliable repairer as soon as possible. Make sure to replace the tire pressure warning valve and transmitter when replacing the tire. (→P.336)

If the hybrid system will not start

Reasons for the hybrid system not starting vary depending on the situation. Check the following and perform the appropriate procedure:

The hybrid system will not start even though the correct starting procedure is being followed. (→P.173, 175)

One of the following may be the cause of the problem:

- Vehicles with a smart entry & start system: The electronic key may not be functioning properly. (→P.407)
- There may not be sufficient fuel in the vehicle's tank. Refuel the vehicle.
- There may be a malfunction in the immobilizer system. (→P.84)
- There may be a malfunction in the steering lock system.
- Vehicles with a smart entry & start system: The hybrid system may be malfunctioning due to an electrical problem such as electronic key battery depletion or a blown fuse. However, depending on the type of malfunction, an interim measure is available to start the hybrid system.

(→P.406)

- The temperature of the hybrid battery (traction battery) may be extremely low (below approximately -30°C [-22°F]). (→P.173, 175)

The interior lights and headlights are dim, or the horn does not sound or sounds at a low volume.

One of the following may be the cause of the problem:

- The 12-volt battery may be discharged. (→P.409)
- The 12-volt battery terminal connections may be loose or corroded. (→P.330)

The interior lights and headlights do not turn on, or the horn does not sound.

One of the following may be the cause of the problem:

- The 12-volt battery may be discharged. (→P.409)
- One or both of the 12-volt battery terminals may be disconnected. (→P.330)

Contact any authorized Toyota retailer or Toyota authorized repairer, or any reliable repairer if the problem cannot be repaired, or if repair procedures are unknown.

Emergency start function (vehicles with a smart entry & start system)

When the hybrid system does not start, the following steps can be used as an interim measure to start the hybrid system if the power switch is functioning normally. Do not use this starting procedure except in case of emergency.

- 1 Pull the parking brake switch to check that the parking brake is set. (→P.184)

Parking brake indicator will come on.

- 2 Shift the shift lever to P.
- 3 Turn the power switch to ACC.
- 4 Press and hold the power switch for about 15 seconds while depressing the brake pedal firmly.

Even if the hybrid system can be started using the above steps, the system may be malfunctioning. Have the vehicle inspected by any authorized Toyota retailer or Toyota authorized repairer, or any reliable repairer.

If you lose your keys

New genuine keys can be made by any authorized Toyota retailer or Toyota authorized repairer, or any reliable repairer using the other key (vehicles without a smart entry & start system) or mechanical key (vehicles with a smart entry & start system) and the key number stamped on your key number plate.

Keep the plate in a safe place such as your wallet, not in the vehicle.

**NOTICE**

■ **When an electronic key is lost (vehicles with a smart entry & start system)**

If the electronic key remains lost, the risk of vehicle theft increases significantly. Visit any authorized Toyota retailer or Toyota authorized repairer, or any reliable repairer immediately with all remaining electronic keys that were provided with your vehicle.

If the electronic key does not operate properly (vehicles with a smart entry & start system)

If communication between the electronic key and vehicle is interrupted (→P.142) or the electronic key cannot be used because the battery is depleted, the smart entry & start system and wireless remote control cannot be used. In such cases, the doors can be opened and the hybrid system can be started by following the procedure below.

■ **When the electronic key does not work properly**

- Make sure that the smart entry & start system has not been deactivated in the customization setting. If it is off, turn the function on. (Customizable features: →P.431)
- Check if battery-saving mode is set. If it is set, cancel the function. (→P.141)

**NOTICE**

■ **In case of a smart entry & start system malfunction or other key-related problems**

Take your vehicle with all the electronic keys provided with your vehicle to any authorized Toyota retailer or Toyota authorized repairer, or any reliable repairer.

Locking and unlocking the doors

Use the mechanical key (→P.131) in order to perform the following operations:

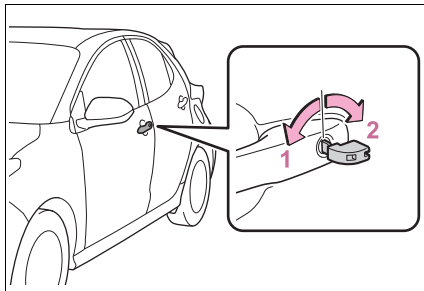

- 1 Locks all the doors
- 2 Unlocks all the doors

Key linked functions

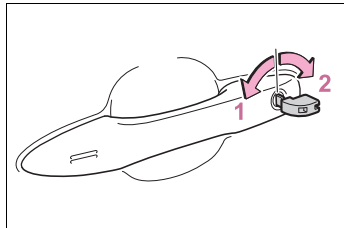

- 1 Closes the windows (turn and hold)*
- 2 Opens the windows (turn and hold)*

*: These settings must be customized at any authorized Toyota retailer or Toyota authorized repairer, or any reliable repairer.

WARNING

When using the mechanical key and operating the power windows

Operate the power window after checking to make sure that there is no possibility of any passenger having any of their body parts caught in the window.

Also, do not allow children to operate the mechanical key. It is possible for children and other passengers to get caught in the power window.

Starting the hybrid system

- 1 Ensure that the shift lever is in P and depress the brake pedal.
- 2 Touch the area behind the lock button and unlock button on the electronic key to the power switch.

When the electronic key is detected, a buzzer sounds and the power switch will turn to ON.

When the smart entry & start system is deactivated in customization setting, the power switch will turn to ACC.

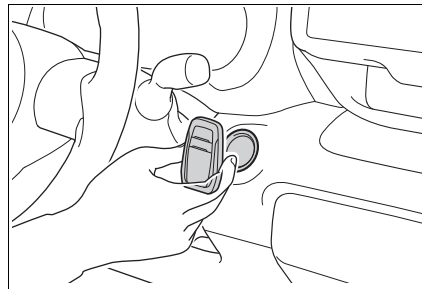

- 3 Firmly depress the brake pedal and check that  is shown on the multi-information display.

- 4** Press the power switch shortly and firmly.

In the event that the hybrid system still cannot be started, contact any authorized Toyota retailer or Toyota authorized repairer, or any reliable repairer.

■ Stopping the hybrid system

Shift the shift lever to P and press the power switch as you normally do when stopping the hybrid system.

■ Electronic key battery

As the above procedure is a temporary measure, it is recommended that the electronic key battery be replaced immediately when the battery is depleted. (→P.351)

■ Alarm (if equipped)

Using the mechanical key to lock the doors will not set the alarm system. If a door is unlocked using the mechanical key when the alarm system is set, the alarm may be triggered. (→P.86)

■ Changing power switch modes

Release the brake pedal and press the power switch in step **3** above. The hybrid system does not start and modes will be changed each time the switch is pressed. (→P.177)

If the 12-volt battery is discharged

The following procedures may be used to start the hybrid system if the 12-volt battery is discharged.

You can also call any authorized Toyota retailer or Toyota authorized repairer, or any reliable repairer or a qualified repair shop.

Restarting the hybrid system

If you have a set of jumper (or booster) cables and a second vehicle with a 12-volt battery, you can jump start your vehicle by following the steps below.

- 1** Vehicles with an alarm (→P.86):
Confirm that the electronic key is being carried.

When connecting the jumper (or booster) cables, depending on the situation, the alarm may activate and doors locked. (→P.87)

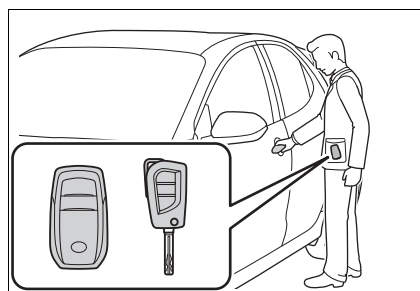

410 7-2. Steps to take in an emergency

2 Open the hood (→P.322) and fuse box cover.

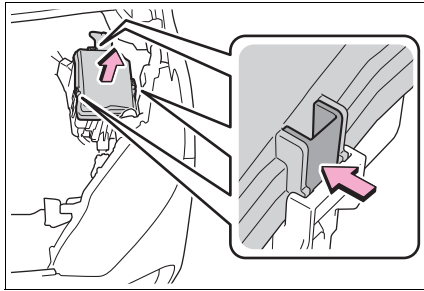

3 Open the exclusive jump starting terminal cover.

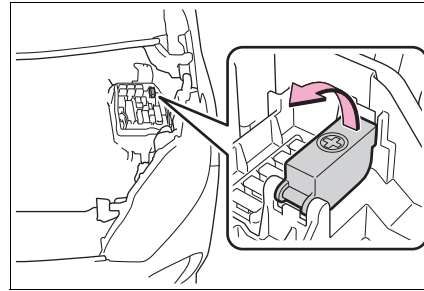

4 Connect a positive jumper cable clamp to **A** on your vehicle and connect the clamp on the other end of the positive cable to **B** on the second vehicle. Then, connect a negative cable clamp to **C** on the second vehicle and connect the clamp at the other end of the negative cable to **D**.

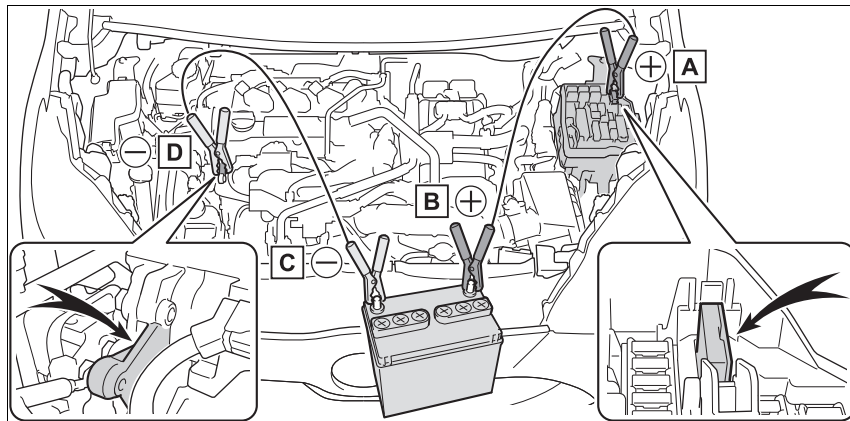

A Exclusive jump starting terminal (your vehicle)

B Positive (+) battery terminal (second vehicle)

C Negative (-) battery terminal (second vehicle)

D Solid, stationary, unpainted metallic point away from the exclusive jump starting terminal and any moving parts as shown in the illustration

5 Start the engine of the second vehicle. Increase the engine speed slightly and maintain at that level for approximately 5

minutes to recharge the 12-volt battery of your vehicle.

- 6 Vehicles with a smart entry & start system: Open and close any of the doors of your vehicle with the power switch OFF.
- 7 Maintain the engine speed of the second vehicle and start the hybrid system of your vehicle by turning the power switch to ON.
- 8 Make sure the "READY" indicator comes on. If the indicator does not come on, contact any authorized Toyota retailer or Toyota authorized repairer, or any reliable repairer.
- 9 Once the hybrid system has started, remove the jumper cables in the exact reverse order from which they were connected.
- 10 Close the exclusive jump starting terminal cover and install the fuse box cover to its original position.

Once the hybrid system starts, have the vehicle inspected at any authorized Toyota retailer or Toyota authorized repairer, or any reliable repairer as soon as possible.

■ Starting the hybrid system when the 12-volt battery is discharged

The hybrid system cannot be started by push-starting.

■ To prevent 12-volt battery discharge

- Turn off the headlights and the audio

system while the hybrid system is off.

- Turn off any unnecessary electrical components when the vehicle is running at a low speed for an extended period, such as in heavy traffic.

■ When the 12-volt battery is removed or discharged

- Information stored in the ECU is cleared. When the 12-volt battery is depleted, have the vehicle inspected at any authorized Toyota retailer or Toyota authorized repairer, or any reliable repairer.
- Some systems may require initialization. (→P.440)

■ When removing the 12-volt battery terminals

When the 12-volt battery terminals are removed, the information stored in the ECU is cleared. Before removing the 12-volt battery terminals, contact any authorized Toyota retailer or Toyota authorized repairer, or any reliable repairer.

■ Charging the 12-volt battery

The electricity stored in the 12-volt battery will discharge gradually even when the vehicle is not in use, due to natural discharge and the draining effects of certain electrical appliances. If the vehicle is left for a long time, the 12-volt battery may discharge, and the hybrid system may be unable to start. (The 12-volt battery recharges automatically while the hybrid system is operating.)

■ When recharging or replacing the 12-volt battery (vehicles with a smart entry & start system)

- In some cases, it may not be possible to unlock the doors using the smart entry & start system when the 12-volt battery is discharged. Use the wireless remote control or the mechanical key to lock or unlock the doors.
- The hybrid system may not start on the first attempt after the 12-volt battery has recharged but will start normally after the second attempt. This is

not a malfunction.

- The power switch mode is memorized by the vehicle. When the 12-volt battery is reconnected, the system will return to the mode it was in before the 12-volt battery was discharged. Before disconnecting the 12-volt battery, turn the power switch off. If you are unsure what mode the power switch was in before the 12-volt battery discharged, be especially careful when reconnecting the 12-volt battery.

■ **When replacing the 12-volt battery**

- Use a Central Degassing type 12-volt battery (European Regulations).
- Use a battery that the case size is same as the previous one, 20 hour rate capacity (20HR) is equivalent or greater, and performance rating (CCA) is equivalent or greater. Check the label on top of the battery for the battery size and specifications (ex. LN0, 35Ah, 264A).
- If the sizes differ, the 12-volt battery cannot be properly secured.
- If the 20 hour rate capacity is low, even if the time period where the vehicle is not used is a short time, the 12-volt battery may discharge and the hybrid system may not be able to start.
- Use a ventilation type calcium battery
- Use a 12-volt battery with a handle. If a 12-volt battery without a handle is used, removal is more difficult.
- When removing the 12-volt battery: →P.330
- After replacing, firmly attach the following items to the exhaust hole of the 12-volt battery.
 - Use the exhaust hose that was attached to the 12-volt battery before replacing and confirm that it is firmly connected to the hole section of the vehicle.
 - Use the exhaust hole plug included with the 12-volt battery replaced or the one installed on the 12-volt battery

prior to the replacement. (Depending on the 12-volt battery to be replaced, the exhaust hole may be plugged.)

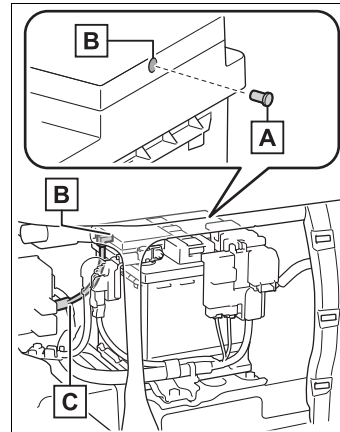

A Exhaust hole plug

B Exhaust hole

C Exhaust hose

- For details, consult any authorized Toyota retailer or Toyota authorized repairer, or any reliable repairer.

WARNING

■ **When removing the 12-volt battery terminals**

Always remove the negative (-) terminal first. If the positive (+) terminal contacts any metal in the surrounding area when the positive (+) terminal is removed, a spark may occur, leading to a fire in addition to electrical shocks and death or serious injury.

■ **Avoiding 12-volt battery fires or explosions**

Observe the following precautions to prevent accidentally igniting the flammable gas that may be emitted from the 12-volt battery:

**WARNING**

- Make sure each jumper cable is connected to the correct terminal and that it is not unintentionally in contact with any other than the intended terminal.
- Do not allow the other end of the jumper cable connected to the “+” terminal to come into contact with any other parts or metal surfaces in the area, such as brackets or unpainted metal.
- Do not allow the + and - clamps of the jumper cables to come into contact with each other.
- Do not smoke, use matches, cigarette lighters or allow open flame near the 12-volt battery.

■ 12-volt battery precautions

The 12-volt battery contains poisonous and corrosive acidic electrolyte, while related parts contain lead and lead compounds. Observe the following precautions when handling the 12-volt battery:

- When working with the 12-volt battery, always wear safety glasses and take care not to allow any battery fluids (acid) to come into contact with skin, clothing or the vehicle body.
- Do not lean over the 12-volt battery.
- In the event that battery fluid comes into contact with the skin or eyes, immediately wash the affected area with water and seek medical attention. Place a wet sponge or cloth over the affected area until medical attention can be received.
- Always wash your hands after handling the 12-volt battery support, terminals, and other battery-related parts.

- Do not allow children near the 12-volt battery.

■ After recharging the 12-volt battery

Have the 12-volt battery inspected at any authorized Toyota retailer or Toyota authorized repairer, or any reliable repairer as soon as possible.

If the 12-volt battery is deteriorating, continued use may cause the 12-volt battery to emit a malodorous gas, which may be detrimental to the health of passengers.

■ When replacing the 12-volt battery

- For information regarding 12-volt battery replacement, contact any authorized Toyota retailer or Toyota authorized repairer, or any reliable repairer.
- After replacing, securely attach the exhaust hose and exhaust hole plug to the exhaust hole of the replaced 12-volt battery. If not properly installed, gases (hydrogen) may leak into the vehicle interior, and there is the possible danger of the gas igniting and exploding.

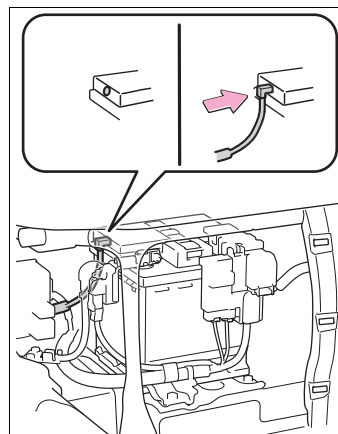

7

When trouble arises

 NOTICE

■ **When handling jumper cables**
When connecting the jumper cables, ensure that they do not become entangled in the cooling fan, etc.

■ **To prevent damaging the vehicle**
The exclusive jump starting terminal is to be used when charging the 12-volt battery from another vehicle in an emergency. It cannot be used to jump start another vehicle.

If your vehicle overheats

The following may indicate that your vehicle is overheating.

- The engine coolant temperature gauge (→P.94, 99) is in the red zone or a loss of hybrid system power is experienced. (For example, the vehicle speed does not increase.)
- “Engine Coolant Temp High Stop in a Safe Place See Owner’s Manual” or “Hybrid System Overheated Output Power Reduced” is shown on the multi-information display.
- Steam comes out from under the hood.

Correction procedures

- ▶ If the engine coolant temperature gauge enters the red zone or “Engine Coolant Temp High Stop in a Safe Place See Owner’s Manual” is shown on the multi-information display
- 1 Stop the vehicle in a safe place and turn off the air conditioning system, and then stop the hybrid system.
- 2 If you see steam: Carefully lift the hood after the steam subsides.
If you do not see steam: Carefully lift the hood.

- 3** After the hybrid system has cooled down sufficiently, inspect the hoses and radiator core (radiator) for any leaks.

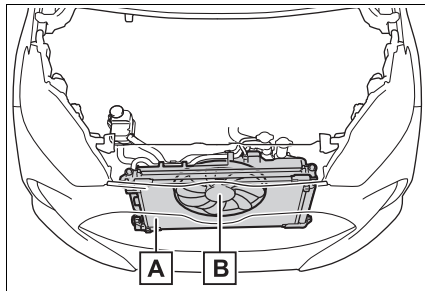

- A** Radiator
- B** Cooling fan

If a large amount of coolant leaks, immediately contact any authorized Toyota retailer or Toyota authorized repairer, or any reliable repairer.

- 4** The coolant level is satisfactory if it is between the “F” and “L” lines on the reservoir.

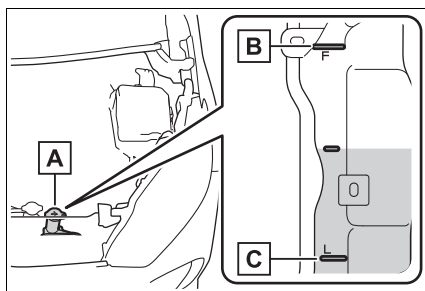

- A** Reservoir
- B** “F” line
- C** “L” line

- 5** Add coolant if necessary.
Water can be used in an emergency if

coolant is unavailable.

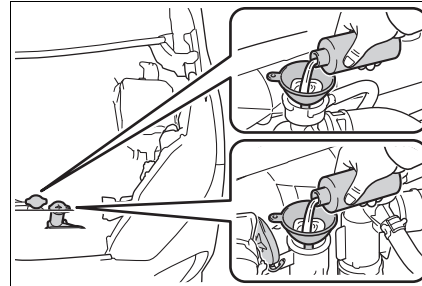

- 6** Start the hybrid system and turn the air conditioning system on to check that the radiator cooling fan operates and to check for coolant leaks from the radiator or hoses.

The fan operates when the air conditioning system is turned on immediately after a cold start. Confirm that the fan is operating by checking the fan sound and air flow. If it is difficult to check these, turn the air conditioning system on and off repeatedly. (The fan may not operate in freezing temperatures.)

- 7** If the fan is not operating: Stop the hybrid system immediately and contact any authorized Toyota retailer or Toyota authorized repairer, or any reliable repairer. If the fan is operating: Have the vehicle inspected at the nearest any authorized Toyota retailer or Toyota authorized repairer, or any reliable repairer.

- ▶ If “Hybrid System Overheated Output Power Reduced” is shown on the multi-information display
- 1** Stop the vehicle in a safe place.

416 7-2. Steps to take in an emergency

- 2 Stop the hybrid system and carefully lift the hood.
- 3 After the hybrid system has cooled down, inspect the hoses and radiator core (radiator) for any leaks.

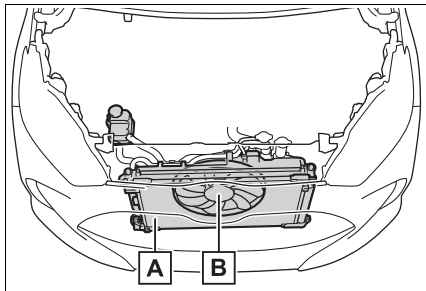

- A Radiator
- B Cooling fan

If a large amount of coolant leaks, immediately contact any authorized Toyota retailer or Toyota authorized repairer, or any reliable repairer.

- 4 The coolant level is satisfactory if it is between the "F" or "L" lines on the reservoir.

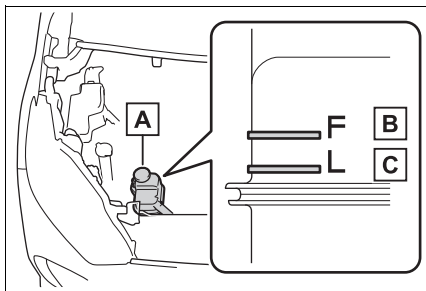

- A Reservoir
- B "F" line
- C "L" line

- 5 Add coolant if necessary.

If water was added in an emergency, have the vehicle inspected at any authorized Toyota retailer or Toyota authorized repairer, or any reliable repairer as soon as possible.

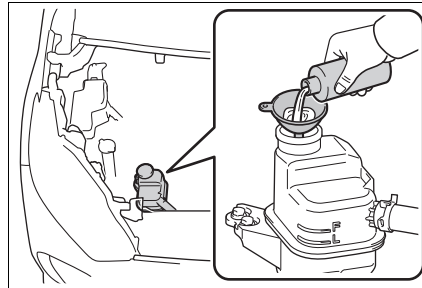

- 6 After stopping the hybrid system and waiting for 5 minutes or more, start the hybrid system again and check for the multi-information display. If the message does not disappear: Stop the hybrid system and contact any authorized Toyota retailer or Toyota authorized repairer, or any reliable repairer. If the message is not displayed: The hybrid system temperature has dropped and the vehicle may be driven normally.

However, if the message appears again frequently, contact any authorized Toyota retailer or Toyota authorized repairer, or any reliable repairer.

WARNING

When inspecting under the hood of your vehicle

Observe the following precautions. Failure to do so may result in serious injury such as burns.

⚠ WARNING

- If steam is seen coming from under the hood, do not open the hood until the steam has subsided. The engine compartment may be very hot.
- After the hybrid system has been turned off, check that the “READY” indicator is off. When the hybrid system is operating, the gasoline engine may automatically start, or the cooling fan may suddenly operate even if the gasoline engine stops. Do not touch or approach rotating parts such as the fan, which may lead to fingers or clothing (especially a tie, a scarf or a muffler) getting caught, resulting in serious injury.
- Do not loosen the coolant reservoir caps while the hybrid system and radiator are hot. High temperature steam or coolant could spray out.

⚠ NOTICE**■ When adding engine/power control unit coolant**

Add coolant slowly after the hybrid system has cooled down sufficiently. Adding cool coolant to a hot hybrid system too quickly can cause damage to the hybrid system.

■ To prevent damage to the cooling system

Observe the following precautions:

- Avoid contaminating the coolant with foreign matter (such as sand or dust etc.).
- Do not use any coolant additive.

If the vehicle becomes stuck

Carry out the following procedures if the tires spin or the vehicle becomes stuck in mud, dirt or snow:

Recovering procedure

- 1 Stop the hybrid system. Set the parking brake and shift the shift lever to P.
- 2 Remove the mud, snow or sand from around the front wheels.
- 3 Place wood, stones or some other material under the front wheels to help provide traction.
- 4 Restart the hybrid system.
- 5 Shift the shift lever to D or R and release the parking brake. Then, while exercising caution, depress the accelerator pedal.

■ When it is difficult to free the vehicle

Press the  switch to turn off TRC.

A message will be shown on the multi-information display.





WARNING

■ **When attempting to free a stuck vehicle**

If you choose to push the vehicle back and forth to free it, make sure the surrounding area is clear to avoid striking other vehicles, objects or people. The vehicle may also lunge forward or lunge back suddenly as it becomes free. Use extreme caution.

■ **When shifting the shift lever**

Be careful not to shift the shift lever with the accelerator pedal depressed. This may lead to unexpected rapid acceleration of the vehicle that may cause an accident resulting in death or serious injury.



NOTICE

■ **To avoid damaging the transmission and other components**

- Avoid spinning the front wheels and depressing the accelerator pedal more than necessary.
- If the vehicle remains stuck even after these procedures are performed, the vehicle may require towing to be freed.

Vehicle specifications

8

419

8-1. Specifications

Maintenance data (fuel, oil level, etc.)420

Fuel information430

8-2. Customization

Customizable features431

8-3. Initialization

Items to initialize440

8-4. Certifications

Certifications441

8

Vehicle specifications

Maintenance data (fuel, oil level, etc.)

Dimensions and weights

Overall length		3940 mm (155.1 in.)
Overall width		1745 mm (68.7 in.)
Overall height* ¹		1500 mm (59.1 in.) 1505 mm (59.3 in.)* ²
Wheelbase		2560 mm (100.8 in.)
Tread	Front	1521 mm (59.9 in.)* ³ 1531 mm (60.3 in.)* ⁴
	Rear	1518 mm (59.8 in.)* ³ 1528 mm (60.2 in.)* ⁴
Gross vehicle mass		1615 kg (3561.0 lb.)
Maximum permissible axle capacity	Front	900 kg (1984.5 lb.)
	Rear	840 kg (1852.2 lb.)
Drawbar load* ⁵		50 kg (110.2 lb.)
Towing capacity* ⁵	Without brake	450 kg (992.2 lb.)
	With brake	450 kg (992.2 lb.)

*1: Unladen vehicles

*2: Vehicles with panoramic roof shade

*3: Vehicles with 16-inch tires or 17-inch tires

*4: Vehicles with 15-inch tires

*5: Vehicles with towing packages

Vehicle identification

■ **Vehicle identification number**

The vehicle identification number (VIN) is the legal identifier for your vehicle. This is the primary identification number for your Toyota. It is used in registering the ownership of your vehicle.

This number is stamped under the right-hand front seat.

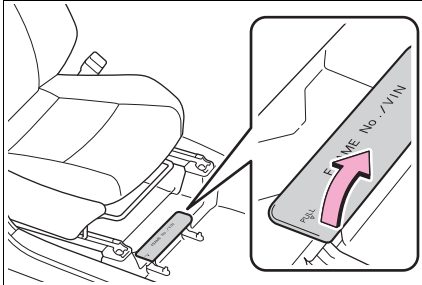

This number is also stamped on the top left of the instrument panel.

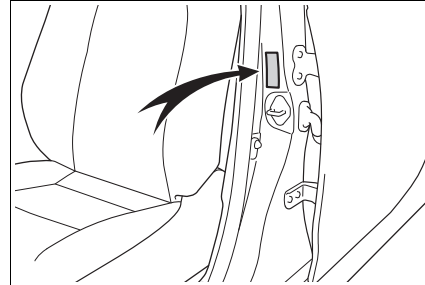

■ **Engine number**

The engine number is stamped on the engine block as shown.

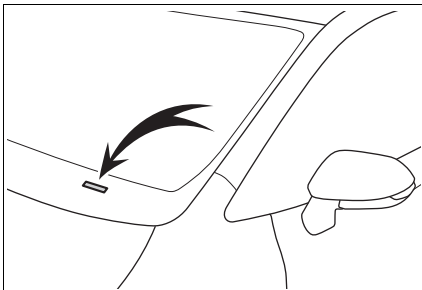

This number is also on the manufacturer's label.

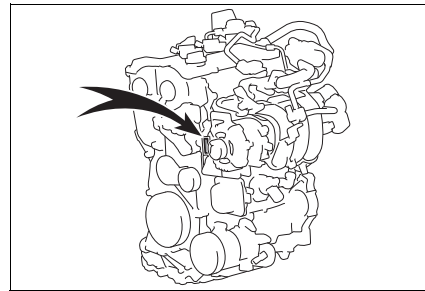

Engine

Model	M15A-FXE
Type	3-cylinder in line, 4-cycle, gasoline
Bore and stroke	80.5 × 97.6 mm (3.16 × 3.84 in.)
Displacement	1490 cm ³ (90.9 cu. in.)
Valve clearance	Automatic adjustment

Fuel	
Fuel type	<p>When you find these types of fuel label at the gas station, use only the fuel with one of the following labels.</p> <div style="text-align: center;">  </div> <p>EU area: Unleaded gasoline conforming to European standard EN228 only</p> <p>Except EU area: Unleaded gasoline only</p>
Research Octane Number	95 or higher
Fuel tank capacity (Reference)	<p>▶ Vehicles without rear wiper 33.0 L (8.7 gal., 7.2 Imp. gal.)</p> <p>▶ Vehicles with rear wiper 36.0 L (9.5 gal., 7.9 Imp. gal.)</p>

Electric motor (traction motor)	
Type	Permanent magnet motor
Maximum output	59 kW
Maximum torque	141 N•m (14.4 kgf•m, 104 ft•lbf)

Hybrid battery (traction battery)	
Type	Lithium-ion battery
Voltage	3.7 V/cell
Capacity	4.3 Ah
Quantity	48 cells
Nominal voltage	177.6 V

Lubrication system**Oil capacity (Drain and refill [Reference*])**

With filter	3.6 L (3.8 qt., 3.2 Imp. qt.)
Without filter	3.3 L (3.5 qt., 2.9 Imp. qt.)

*: The engine oil capacity is a reference quantity to be used when changing the engine oil. Warm up the engine and turn off the hybrid system, wait more than 5 minutes, and check the oil level on the dipstick.

Engine oil selection

Gasoline Engine —

“Toyota Genuine Motor Oil” is used in your Toyota vehicle. Toyota recommends the use of approved “Toyota Genuine Motor Oil”.

Another motor oil of matching quality can also be used.

Oil grade:

0W-8: JASO GLV-1

0W-16:

API grade SN “Resource-Conserving”, SN PLUS “Resource-Conserving” or SP “Resource-Conserving”; or ILSAC GF-6B multigrade engine oil

0W-20 and 5W-30:

API grade SM “Energy-Conserving”, SN “Resource-Conserving”, SN PLUS “Resource-Conserving” or SP “Resource-Conserving”; or ILSAC GF-6A multigrade engine oil
Recommended viscosity (SAE):

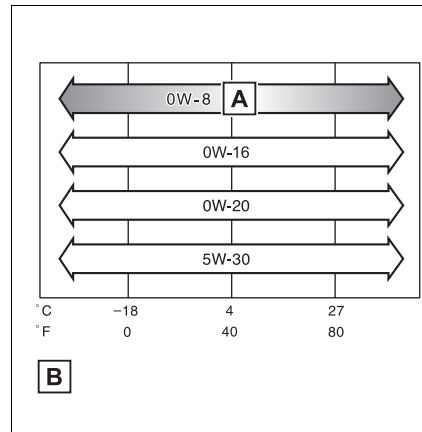

A Preferred

B Temperature range anticipated before next oil change

SAE 0W-8 is filled into your Toyota vehicle at manufacturing, and the best choice for good fuel economy and good starting in cold weather. If SAE 0W-8 oil is not available, SAE 0W-16 or 0W-20 oil may be used. However, it should be replaced with SAE 0W-8 at the next oil change.

Oil viscosity (0W-8 is explained here as an example):

- The 0W in 0W-8 indicates the characteristic of the oil which allows cold startability. Oils with a lower value before the W allow for easier starting of the engine in cold weather.
- The 8 in 0W-8 indicates the viscosity characteristic of the oil when the oil is at high temperature. An oil with a higher viscosity (one with a higher value) may be better suited if the vehicle is

operated at high speeds, or under extreme load conditions.

the container.

How to read oil container labels:

Either or both API registered marks are added to some oil containers to help you select the oil you should use.

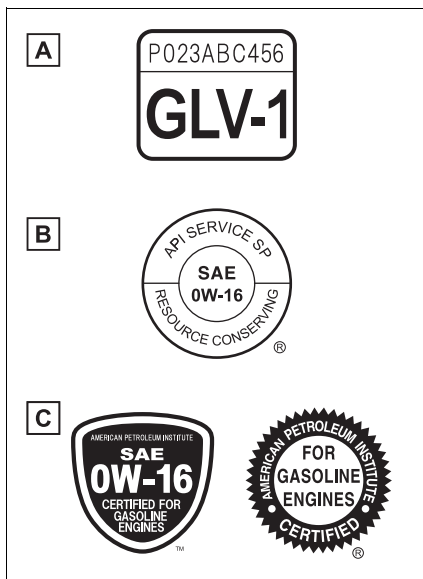

A JASO GLV-1 Mark

B API Service Symbol

Top portion: “API SERVICE SP” means the oil quality designation by American Petroleum Institute (API).

Center portion: “SAE 0W-16” means the SAE viscosity grade.

Lower portion: “Resource-Conserving” means that the oil has fuel-saving and environmental protection capabilities.

C ILSAC Certification Mark

The International Lubricant Specification Advisory Committee (ILSAC) Certification Mark is displayed on the front of

Cooling system

Capacity (Reference)	Gasoline engine	<ul style="list-style-type: none"> ▶ Right-hand drive vehicles 5.11 L (5.4 qt., 4.5 Imp. qt.) ▶ Left-hand drive vehicles 5.09 L (5.4 qt., 4.5 Imp. qt.)
	Power control unit	1.3 L (1.4 qt., 1.1 Imp. qt.)
Coolant type		<p>Use either of the following:</p> <ul style="list-style-type: none"> • “Toyota Super Long Life Coolant” • Similar high-quality ethylene glycol-based non-silicate, non-amine, non-nitrite, and non-borate coolant with long-life hybrid organic acid technology <p>Do not use plain water alone.</p>

Ignition system (spark plug)

Make	DENSO FC16HR-Q8 NGK DILKAR6T8
Gap	0.8 mm (0.031 in.)

**NOTICE**

■ Iridium-tipped spark plugs

Use only iridium-tipped spark plugs. Do not adjust the spark plug gap.

Electrical system (12-volt battery)

Open voltage at 20°C (68°F):	12.0 V or higher (Turn the power switch off and turn on the high beam headlights for 30 seconds.)
Charging rates	
Quick charge	15 A max.
Slow charge	5 A max.

Hybrid transmission

Fluid capacity*	2.6 L (2.7 qt., 2.3 Imp. qt.)
Fluid type	"Toyota Genuine ATF WS"

*: The fluid capacity is a reference quantity.
 If replacement is necessary, contact any authorized Toyota retailer or Toyota authorized repairer, or any reliable repairer.



NOTICE

■ Hybrid transmission fluid type

Using transmission fluid other than the above type may cause abnormal noise or vibration, or ultimately damage the transmission of your vehicle.

Brakes

Pedal clearance* ¹	82 mm (3.2 in.) Min.
Pedal free play	1 — 6 mm (0.04 — 0.24 in.)
Parking brake indicator* ²	When pulling the parking brake switch for 1 to 2 seconds: comes on When pushing the parking brake switch for 1 to 2 seconds: turns off
Fluid type	SAE J1704 or FMVSS No.116 DOT 4

*¹: Minimum pedal clearance when depressed with a force of 300 N (31.0 kgf, 67.4 lbf) while the hybrid system is operating.

*²: Make sure to confirm that the brake warning light (yellow) does not illuminate. (If the brake warning light illuminates, refer to P.91, 374.)

Steering

Free play	Less than 30 mm (1.2 in.)
-----------	---------------------------

Tires and wheels

▶ 15-inch tires

Tire size		185/65R15 88H	
Tire inflation pressure (Recommended cold tire inflation pressure)	Vehicle speed	Front wheel kPa (kgf/cm ² or bar, psi)	Rear wheel kPa (kgf/cm ² or bar, psi)
	More than 160 km/h (100 mph)	Type A*: 280 (2.8, 41) Type B*: 250 (2.5, 36)	Type A*: 280 (2.8, 41) Type B*: 240 (2.4, 35)
	160 km/h (100 mph) or less	Type A*: 280 (2.8, 41) Type B*: 230 (2.3, 33)	Type A*: 280 (2.8, 41) Type B*: 220 (2.2, 32)
Wheel size		15 × 6J	
Wheel nut torque		103 N•m (10.5 kgf•m, 76 ft•lbf)	

* : The tire inflation pressure is specified on the tire-loading information label.
(→P.342)

▶ 16-inch tires

Tire size		195/55R16 87V	
Tire inflation pressure (Recommended cold tire inflation pressure)	Vehicle speed	Front wheel kPa (kgf/cm ² or bar, psi)	Rear wheel kPa (kgf/cm ² or bar, psi)
	More than 160 km/h (100 mph)	240 (2.4, 35)	220 (2.2, 32)
	160 km/h (100 mph) or less	220 (2.2, 32)	200 (2.0, 29)
Wheel size		16 × 6J	
Wheel nut torque		103 N•m (10.5 kgf•m, 76 ft•lbf)	

► 17-inch tires

Tire size	205/45R17 84W	
Tire inflation pressure (Recommended cold tire inflation pressure)	Front wheel kPa (kgf/cm ² or bar, psi)	Rear wheel kPa (kgf/cm ² or bar, psi)
	220 (2.2, 32)	200 (2.0, 29)
Wheel size	17 × 6 1/2J	
Wheel nut torque	103 N•m (10.5 kgf•m, 76 ft•lbf)	

► Compact spare tire (if equipped)

Tire size	T125/70D16 96M	
Tire inflation pressure (Recommended cold tire inflation pressure)	420 kPa (4.2 kgf/cm ² or bar, 60 psi)	
Wheel size	16 × 4T	
Wheel nut torque	103 N•m (10.5 kgf•m, 76 ft•lbf)	

■ **When towing a trailer**

Add 20.0 kPa (0.2 kgf/cm² or bar, 3 psi) to the recommended tire inflation pressure, and drive at speeds below 100 km/h (62 mph).

Light bulbs

	Light bulbs	W	Type
Exterior	Halogen headlights (bulb type)	55	A
	Front fog lights (bulb type)	19	B
	Front position lights (bulb type)	5	C
	Front turn signal lights (bulb type)	21	D
	Rear turn signal lights (bulb type)	21	D
	License plate light	5	C

	Light bulbs	W	Type
Interior	Interior lights/personal lights	5	C
	Vanity lights (if equipped)	8	C
	Luggage compartment light	5	C

A: HIR2 halogen bulbs

B: H16

C: Wedge base bulbs (clear)

D: Wedge base bulbs (amber)

Fuel information

When you find these types of fuel label at the gas station, use only the fuel with one of the following labels.



EU area:

You must only use unleaded gasoline conforming to European standard EN228. Select unleaded gasoline with a Research Octane Number of 95 or higher for optimum engine performance.

Except EU area:

You must only use unleaded gasoline. Select unleaded gasoline with a Research Octane Number of 95 or higher for optimum engine performance.

■ Use of ethanol blended gasoline in a gasoline engine

Toyota allows the use of ethanol blended gasoline where the ethanol content is up to 10%. Make sure that the ethanol blended gasoline to be used has a Research Octane Number that follows the above.

■ If your engine knocks

- Consult any authorized Toyota retailer or Toyota authorized repairer, or any reliable repairer.
- You may occasionally notice light knocking for a short time while accelerating or driving uphill. This is normal

and there is no need for concern.

NOTICE

■ Notice on fuel quality

- Do not use improper fuels. If improper fuels are used, the engine will be damaged.
- Do not use gasoline with metallic additives, for example manganese, iron or lead, otherwise it may cause damage on your engine or emission control system.
- Do not add aftermarket fuel additives which contain metallic additives.
- EU area: Bioethanol fuel sold under names such as "E50" or "E85" and fuel containing a large amount of ethanol should not be used. The use of these fuels will damage the vehicle's fuel system. In case of any doubt, ask any authorized Toyota retailer or Toyota authorized repairer, or any reliable repairer.
- Except EU area: Bioethanol fuel sold under names such as "E50" or "E85" and fuel containing a large amount of ethanol should not be used. Your vehicle can use gasoline mixed with 10% max ethanol. The use of fuel with more than 10% ethanol content (E10) will damage the vehicle's fuel system. You must ensure that refueling is carried out only from a source where fuel specification and quality can be guaranteed. In case of any doubt, ask any authorized Toyota retailer or Toyota authorized repairer, or any reliable repairer.
- Do not use the methanol blended gasoline such as M15, M85, M100. The use of gasoline containing methanol may cause engine damage or failure.

Customizable features

Your vehicle includes a variety of electronic features that can be personalized to suit your preferences. The settings of these features can be changed using the multi-information display, the navigation/multi-media system screen or at any authorized Toyota retailer or Toyota authorized repairer, or any reliable repairer.

Customizing vehicle features

■ Changing by using the navigation/multimedia system screen (vehicles with 7-inch/8-inch display multimedia system)

- 1 Press the "MENU" button.
- 2 Select "Setup" on the "Menu" screen.
- 3 Select "Vehicle" on the "Setup" screen.
- 4 Select "Vehicle customization".

Various setting can be changed. Refer to the list of settings that can be changed for details.

■ Changing by using the meter control switches

- 1 Press \langle / \rangle (vertical display) or \wedge / \vee (horizontal display) of the meter control switch to select .

- 2 Press \wedge / \vee (vertical display) or \langle / \rangle (horizontal display) of the meter control switch to select the desired item to be customized.

- 3 Press or press and hold OK .

The available settings will differ depending on if OK is pressed or pressed and held. Follow the instructions on the display.

WARNING

■ During customization

As the hybrid system needs to be operating during customization, ensure that the vehicle is parked in a place with adequate ventilation. In a closed area such as a garage, exhaust gases including harmful carbon monoxide (CO) may collect and enter the vehicle. This may lead to death or a serious health hazard.

NOTICE

■ During customization

To prevent 12-volt battery discharge, ensure that the hybrid system is operating while customizing features.

Customizable features

Some function settings are changed simultaneously with other functions being customized. Contact any authorized Toyota retailer or Toyota authorized repairer, or any reliable repairer for further details.

A Settings that can be changed using the 7-inch/8-inch display multimedia system

B Settings that can be changed using the meter control switches

C Settings that can be changed by any authorized Toyota retailer or Toyota authorized repairer, or any reliable repairer

Definition of symbols: O = Available, — = Not available

■ Alarm* (→P.86)

Function	Default setting	Customized setting	A	B	C
Deactivates the alarm when the doors are unlocked using the key or mechanical key	Off	On	—	—	O

*: If equipped

■ Gauges, meters and multi-information display (→P.94, 99, 103, 109)

Function ^{*1}	Default setting	Customized setting	A	B	C
Language ^{*2}	English	^{*3}	—	O	—
Units ^{*2}	L/100 km	km/L	—	O	—
		miles (MPG) ^{*4}	—	O	—
EV indicator	On	Off	—	O	—
Eco Accelerator Guidance	On	Off	—	O	—
Fuel economy display	Total average (Average fuel consumption [after reset])	Trip average (Average fuel consumption [after start])	—	O	—
		Tank average (Average fuel consumption [after refuel])	—	O	—

Function ^{*1}	Default setting	Customized setting	A	B	C
Audio system linked display ^{*4}	On	Off	—	O	—
Energy monitor	On	Off	—	O	—
Drive information type	After start	After reset	—	O	—
Drive information items (First item)	Distance	Average vehicle speed	—	O	—
		Elapsed time			
Drive information items (Second item)	Elapsed time	Average vehicle speed	—	O	—
		Distance			
Current trip result display	Drive information	Eco score	—	O	—
Pop-up display	On	Off	—	O	—

*1: For details about each function: →P.108, 113

*2: The default setting varies according to country.

*3: Arabic, Spanish, Russian, French, German, Italian, Dutch, Turkish, Polish, Hebrew, Norwegian, Swedish, Danish, Ukrainian, Finnish, Greek, Czech, Portuguese, Romanian, Slovakian, Hungarian, Flemish

*4: If equipped

■ Head-up display* (→P.116)

Function	Default setting	Customized setting	A	B	C
Head-up display	On	Off	—	O	—
Gauge information	Tachometer	Hybrid System Indicator	—	O	—
		No content			
Route guidance to destination/street name*	On	Off	—	O	—
Driving support system display*	On	Off	—	O	—

Function	Default setting	Customized setting	A	B	C
Compass*	On	Off	—	O	—
Audio system operation status*	On	Off	—	O	—

*: If equipped

■ **Smart entry & start system*** and wireless remote control (→P.133, 140)

Function	Default setting	Customized setting	A	B	C
Operation signal (Emergency flashers)	On	Off	O	—	O
Time elapsed before automatic door lock function is activated if door is not opened after being unlocked	30 seconds	60 seconds			
		120 seconds	—	—	O
Open door warning buzzer*	On	Off	—	—	O

*: If equipped

■ **Smart entry & start system*** (→P.133, 139, 140)

Function	Default setting	Customized setting	A	B	C
Smart entry & start system	On	Off	O	—	O
Number of consecutive door lock operations	2 times	As many as desired	—	—	O

*: If equipped

■ **Wireless remote control** (→P.130, 133)

Function	Default setting	Customized setting	A	B	C
Wireless remote control	On	Off	—	—	O

■ Outside rear view mirrors (→P.153)

Function	Default setting	Customized setting	A	B	C
Automatic mirror folding and extending operation*	Linked to the locking/ unlocking of the doors	Off			
		Linked to operation of the power switch	—	—	O

*: If equipped

■ Power windows (→P.156)

Function	Default setting	Customized setting	A	B	C
Key (include mechanical key*) linked operation	Off	On	—	—	O
Wireless remote control linked operation	Off	On	—	—	O
Wireless remote control linked operation signal (buzzer)*	On	Off	—	—	O

*: If equipped

■ Automatic light control system (→P.190)

Function	Default setting	Customized setting	A	B	C
Light sensor sensitivity	Standard	-2 to 2	O	—	O
Headlamp temporary lighting function (Time elapsed before headlights automatically turn off)	30 seconds	60 seconds			
		90 seconds	—	—	O
		120 seconds			

■ Lights (→P.191)

Function	Default setting	Customized setting	A	B	C
Welcome lamp*	On	Off	—	—	O

*: If equipped

■ **PCS (Pre-Collision System)*** (→P.209)

Function	Default setting	Customized setting	A	B	C
PCS (Pre-Collision System)	On	Off	—	O	—
Adjust alert timing	Middle	Early	—	O	—
		Late			

*: If equipped

■ **LTA (Lane Tracing Assist)*** (→P.220)

Function	Customized setting	A	B	C
Lane centering function	On/Off	—	O	—
Alert types	Buzzer/Steering wheel vibration	—	O	—
Alert sensitivity	High/Standard	—	O	—
Vehicle sway warning function	On/Off	—	O	—
Vehicle sway warning sensitivity	High/Standard/Low	—	O	—

*: If equipped

■ **RSA (Road Sign Assist)*¹** (→P.244)

Function	Default setting	Customized setting	A	B	C
RSA (Road Sign Assist)* ²	On	Off	—	O	—
Excess speed notification method* ³	Display only	No notification	—	O	—
		Display and buzzer			
Excess speed notification level	2 km/h (1 mph)	5 km/h (3 mph)	—	O	—
		10 km/h (5 mph)			
No overtaking notification method	Display only	No notification	—	O	—
		Display and buzzer			
Other notifications method (No-entry notification)* ⁴	Display only	No notification	—	O	—
		Display and buzzer			

*¹: If equipped

*²: RSA function becomes On when the power switch is turned to ON.

*3: If a speed limit with supplemental mark is exceeded, the notification buzzer does not operate.

*4: Vehicles with 7-inch/8-inch display navigation system

■ **Dynamic radar cruise control with full-speed range*** (→P.230)

Function	Default setting	Customized setting	A	B	C
Radar Cruise Control with Road Sign Assist	Off	On	—	O	—

*: If equipped

■ **BSM (Blind Spot Monitor)*** (→P.248)

Function	Default setting	Customized setting	A	B	C
BSM (Blind Spot Monitor) function	On	Off	—	O	—
Outside rear view mirror indicator brightness	Bright	Dim	—	O	—
Alert timing for presence of approaching vehicle (sensitivity)	Intermediate	Early	—	O	—
		Late			
		Only when vehicle detected in blind spot			

*: If equipped

■ **Toyota parking assist-sensor*** (→P.253)

Function	Default setting	Customized setting	A	B	C
Toyota parking assist-sensor	On	Off	—	O	—
Buzzer volume	Level2	Level1	—	O	—
		Level3			
Detection distance of the front center sensor	Far	Near	—	—	O
Detection distance of the rear center sensor	Far	Near	—	—	O
Detection distance of the corner sensor	Far	Near	—	—	O

*: If equipped

■ RCTA (Rear Crossing Traffic Alert)* (→P.260)

Function	Default setting	Customized setting	A	B	C
RCTA (Rear Crossing Traffic Alert) function	On	Off	—	O	—
Buzzer volume	Level2	Level1	—	O	—
		Level3			

*: If equipped

■ PKSB (Parking Support Brake)* (→P.265)

Function	Default setting	Customized setting	A	B	C
PKSB (Parking Support Brake) function	On	Off	—	O	—

*: If equipped

■ Automatic air conditioning system (→P.288)

Function	Default setting	Customized setting	A	B	C
Switching between outside air and recirculated air mode linked to automatic mode switch operation	On	Off	O	—	O

■ Rear seat reminder (→P.135)

Function	Default setting	Customized setting	A	B	C
Indication to prevent misplacement in the rear seat	On	Off	—	O	—

■ Illumination (→P.295)

Function	Default setting	Customized setting	A	B	C
Time elapsed before the interior lights turn off	15 seconds	Off	O	—	O
		7.5 seconds			
		30 seconds			
Operation after the power switch is turned off	On	Off	—	—	O

Function	Default setting	Customized setting	A	B	C
Operation when the doors are unlocked	On	Off	—	—	O
Operation when you approach the vehicle with the electronic key on your person*	On	Off	—	—	O
Footwell lights*, center console light* and door trim lights*	On	Off	—	—	O

*: If equipped

■ Vehicle customization

When the smart entry & start system is off, Smart door unlocking cannot be customized.

■ **In the following situations, customize mode in which the settings can be changed through the multi-information display will automatically be turned off**

- A warning message appears after the customize mode screen is displayed
- The power switch is turned off.
- The vehicle begins to move while the customize mode screen is displayed.

Items to initialize

The following items must be initialized for normal system operation after such cases as the 12-volt battery being reconnected, or maintenance being performed on the vehicle:

List of items to initialize

Item	When to initialize	Reference
PKSB (Parking Support Brake)*	<ul style="list-style-type: none"> After reconnecting or changing the 12-volt battery 	P.269
Engine oil maintenance data	<ul style="list-style-type: none"> After maintenance is performed 	P.327
Tire pressure warning system	<ul style="list-style-type: none"> When rotating front and rear tires which have different tire inflation pressures When changing the tire size When the tire inflation pressure is changed such as when changing traveling speed or load weight When changing between two registered wheel sets 	P.337

*: If equipped

Certifications**eCall****■ Certification for eCall**

Manufacturer : Continental Automotive Singapore Pte Ltd
Address : 80 Boon Keng Road, Continental Building Singapore 339780
Model : 19EU NCBOX / 19EU CBOX

Operation frequency (MHz) :

GSM 900 : Tx: 880 – 915 Rx: 925.0 – 960.0

GSM 1800 : Tx: 1710.2 – 1784.8 Rx: 1805.2 – 1879.8

WCDMA Band 1 : Tx: 1920 – 1980 Rx: 2110 – 2170

WCDMA Band 8 : Tx: 880 – 915 Rx: 925 – 960

LTE 1: Tx: 1920 – 1980 Rx: 2110 – 2170

LTE 3: Tx: 1710 – 1785 Rx: 1805 – 1880

LTE 7: Tx: 2500 – 2570 Rx: 2620 – 2690

LTE 8: Tx: 880 – 915 Rx: 925 – 960

LTE 20 : Tx: 832 – 862 Rx: 791 – 821

LTE 26: Tx: 814 – 849 Rx: 859 – 894

GNSS Receiver Frequency: 1559 – 1610

Maximum output power :

GSM 900 2W

GSM 1800 1W

WCDMA Band 1 : 0.25W

WCDMA Band 8 : 0.25W

LTE Band 1, 3, 7, 8, 20, 26 : 0.2W

שם המוצר וייעודו המסחרי: יחידת תקשורת לרכב
שם היצרן וכתובתו: קונטיננטל אוטומוטיב רפובליקת צ'כיה
סימן מסחרי רשום: Continental
EU NCBOX שם דגם: 19
ארץ ייצור: צ'כיה
שנת ייצור: 2019

 The latest "DECLARATION of CONFORMITY" (DoC)
is available at the following address:
<https://www.continental-homologation.com/>

Hereby, Continental Automotive Singapore declares that the radio
equipment type is in compliance with Directive 2014/53/EU.

► For vehicles sold in Ukraine



справжнім (найменування виробника) заявляє, що тип радіобладнання (позначення типу радіобладнання) відповідає Технічному регламенту радіобладнання;
повний текст декларації про відповідність доступний на веб-сайті за такою адресою:
<https://www.continental-homologation.com/en-gl/Toyota>

Immobilizer system

Hereby, TOKAI RIKA CO., LTD. declares that the radio equipment type RI-57BTY is in compliance with Directive 2014/53/EU.

The full text of the EU declaration of conformity is available at the following internet address:

<http://www.tokai-rika.co.jp/pc>

Frequency band: 119 - 135 kHz

Maximum radio-frequency power: 55dB μ A/m@10m

TOKAI RIKA CO., LTD. vakuuttaa, että radiolaitetyyppi RI-57BTY on direktiivin 2014/53/EU mukainen.

EU-vaatimustenmukaisuusvakuutuksen täysimittainen teksti on saatavilla seuraavassa internetosoitteessa:

<http://www.tokai-rika.co.jp/pc>

Radiotaajuus: 119 - 135 kHz

suurin mahdollinen lähetysteho: 55dB μ A/m@10m

Hierbij verklaar ik, TOKAI RIKA CO., LTD., dat het type radioapparatuur RI-57BTY conform is met Richtlijn 2014/53/EU.

De volledige tekst van de EU-conformiteitsverklaring kan worden geraadpleegd op het volgende internetadres:

<http://www.tokai-rika.co.jp/pc>

Frequentieband: 119 - 135 kHz

Maximaal radiofrequentievermogen: 55dB μ A/m@10m

Le soussigné, TOKAI RIKA CO., LTD., déclare que l'équipement radioélectrique du type RI-57BTY est conforme à la directive 2014/53/UE.

Le texte complet de la déclaration UE de conformité est disponible à l'adresse internet suivante:

<http://www.tokai-rika.co.jp/pc>

Bande de fréquences: 119 - 135 kHz

Puissance de radiofréquence maximale: 55dB μ A/m@10m

<p>Härmed försäkrar TOKAI RIKA CO., LTD. att denna typ av radioutrustning RI-57BTY överensstämmer med direktiv 2014/53/EU.</p> <p>Den fullständiga texten till EU-försäkran om överensstämmelse finns på följande webbadress: http://www.tokai-rika.co.jp/pc</p> <p>Frekvensband: 119 - 135 kHz Maximal radiofrekvenseffekt: 55dBμA/m@10m</p>
<p>Hermed erklærer TOKAI RIKA CO., LTD., at radioudstyrstypen RI-57BTY er i overensstemmelse med direktiv 2014/53/EU.</p> <p>EU-overensstemmelseserklæringens fulde tekst kan findes på følgende internetadresse: http://www.tokai-rika.co.jp/pc</p> <p>Frekvensbånd: 119 - 135 kHz Maksimal radiofrekvenseffekt: 55dBμA/m@10m</p>
<p>Hiermit erklärt TOKAI RIKA CO., LTD., dass der Funkanlagentyp RI-57BTY der Richtlinie 2014/53/EU entspricht.</p> <p>Der vollständige Text der EU-Konformitätserklärung ist unter der folgenden Internetadresse verfügbar: http://www.tokai-rika.co.jp/pc</p> <p>Frequenzband: 119 - 135 kHz Abgestrahlte maximale Sendeleistung: 55dBμA/m@10m</p>
<p>Με την παρούσα ο/η TOKAI RIKA CO., LTD., δηλώνει ότι ο ραδιοεξοπλισμός RI-57BTY πληροί την οδηγία 2014/53/ΕΕ.</p> <p>Το πλήρες κείμενο της δήλωσης συμμόρφωσης ΕΕ διατίθεται στην ακόλουθη ιστοσελίδα στο διαδίκτυο: http://www.tokai-rika.co.jp/pc</p> <p>Ζώνη συχνοτήτων: 119 - 135 kHz Μέγιστη ισχύς ραδιοσυχνότητας: 55dBμA/m@10m</p>

Il fabbricante, TOKAI RIKA CO., LTD., dichiara che il tipo di apparecchiatura radio RI-57BTY è conforme alla direttiva 2014/53/UE.

Il testo completo della dichiarazione di conformità UE è disponibile al seguente indirizzo Internet:

<http://www.tokai-rika.co.jp/pc>

Banda di frequenza: 119 - 135 kHz

Potenza massima radiofrequenza: 55dB μ A/m@10m

Por la presente, TOKAI RIKA CO., LTD. declara que el tipo de equipo radioeléctrico RI-57BTY es conforme con la Directiva 2014/53/UE.

El texto completo de la declaración UE de conformidad está disponible en la dirección Internet siguiente:

<http://www.tokai-rika.co.jp/pc>

Banda de frecuencia: 119 - 135 kHz

Potencia máxima de radiofrecuencia: 55dB μ A/m@10m

O(a) abaixo assinado(a) TOKAI RIKA CO., LTD. declara que o presente tipo de equipamento de rádio RI-57BTY está em conformidade com a Diretiva 2014/53/UE.

O texto integral da declaração de conformidade está disponível no seguinte endereço de Internet:

<http://www.tokai-rika.co.jp/pc>

Banda de frequência: 119 - 135 kHz

Potência máxima de radiofrequências: 55dB μ A/m@10m

<p>B'dan, TOKAI RIKA CO., LTD., niddikjara li dan it-tip ta' tagħmir tar-radju RI-57BTY huwa konformi mad-Direttiva 2014/53/UE.</p> <p>It-test kollu tad-dikjarazzjoni ta' konformità tal-UE huwa disponibbli f'dan l-indirizz tal-Internet li ġej: http://www.tokai-rika.co.jp/pc</p> <p>Tiðnisvið: 119 - 135 kHz Håmarks útvarpsbylgjutiðni: 55dBµA/m@10m</p>
<p>Kåesolevaga deklareerib TOKAI RIKA CO., LTD., et kåesolev radioseadme tüüp RI-57BTY vastab direktiivi 2014/53/EL nõuetele.</p> <p>ELi vastavusdeklaratsiooni täielik tekst on kättesaadav järgmisel internetiaadressil: http://www.tokai-rika.co.jp/pc</p> <p>Sagedusriba: 119 - 135 kHz Maksimaalne saatevõimsus: 55dBµA/m@10m</p>
<p>TOKAI RIKA CO., LTD. igazolja, hogy a RI-57BTY típusú rádióberendezés megfelel a 2014/53/EU irányelvnek.</p> <p>Az EU-megfelelőségi nyilatkozat teljes szövege elérhető a következő internetes címen: http://www.tokai-rika.co.jp/pc</p> <p>Frekvenciasáv: 119 - 135 kHz Maximális jelerősség: 55dBµA/m@10m</p>
<p>TOKAI RIKA CO., LTD. týmto vyhlasuje, že rádiové zariadenie typu RI-57BTY je v súlade so smernicou 2014/53/EÚ.</p> <p>Úplné EÚ vyhlásenie o zhode je k dispozícii na tejto internetovej adrese: http://www.tokai-rika.co.jp/pc</p> <p>Frekvenčné pásmo: 119 - 135 kHz Maximálny rádiový výkon: 55dBµA/m@10m</p>

<p>Tímto TOKAI RIKAI CO., LTD. prohlašuje, že typ rádiového zařízení RI-57BTY je v souladu se směrnicí 2014/53/EU.</p> <p>Úplné znění EU prohlášení o shodě je k dispozici na této internetové adrese: http://www.tokai-rika.co.jp/pc</p> <p>Kmitočtové pásmo: 119 - 135 kHz Maximální radiofrekvenční výkon: 55dBμA/m@10m</p>
<p>TOKAI RIKAI CO., LTD. potvrzuje, da je tip radijske opreme RI-57BTY skladen z Direktivo 2014/53/EU.</p> <p>Celotno besedilo izjave EU o skladnosti je na voljo na naslednjem spletnem naslovu: http://www.tokai-rika.co.jp/pc</p> <p>Frekvenčni pas: 119 - 135 kHz Največja moč radijske frekvence: 55dBμA/m@10m</p>
<p>Aš, TOKAI RIKAI CO., LTD., patvirtinu, kad radijo įrenginių tipas RI-57BTY atitinka Direktyvą 2014/53/ES.</p> <p>Visas ES atitikties deklaracijos tekstas prieinamas šiuo interneto adresu: http://www.tokai-rika.co.jp/pc</p> <p>Dažnių juosta: 119 - 135 kHz Didžiausia radijo dažnių galia: 55dBμA/m@10m</p>
<p>Ar šo TOKAI RIKAI CO., LTD. deklarė, ka radioiekārta RI-57BTY atbilst Direktīvai 2014/53/ES.</p> <p>Pilns ES atbilstības deklarācijas teksts ir pieejams šādā interneta vietnē: http://www.tokai-rika.co.jp/pc</p> <p>Frekvenču josla: 119 - 135 kHz Maksimālā radiofrekvenču jauda: 55dBμA/m@10m</p>

<p>TOKAI RIKA CO., LTD. niniejszym oświadcza, że typ urządzenia radiowego RI-57BTY jest zgodny z dyrektywą 2014/53/UE.</p> <p>Pełny tekst deklaracji zgodności UE jest dostępny pod następującym adresem internetowym: http://www.tokai-rika.co.jp/pc</p> <p>Zakres częstotliwości: 119 - 135 kHz Maksymalna moc częstotliwości radiowej: 55dBμA/m@10m</p>
<p>TOKAI RIKA CO., LTD. lýsir því hér með yfir að fjarskiptatækið af gerð RI-57BTY er í samræmi við tilskipun 2014/53/EU.</p> <p>Öll ESB-samræmisýfirlýsingin er tiltæk á eftirfarandi vefslóð: http://www.tokai-rika.co.jp/pc</p> <p>Tíðnisvið: 119 - 135 kHz Hámarks útvarpsbylgjutiðni: 55dBμA/m@10m</p>
<p>TOKAI RIKA CO., LTD. erklærer herved at radioutstyrtypen RI-57BTY er i samsvar med direktivet 2014/53/EU.</p> <p>Hele teksten av EU-samsvarserklæringen kan leses på det følgende nettstedet: http://www.tokai-rika.co.jp/pc</p> <p>Frekvensbånd: 119 - 135 kHz Maksimal radiofrekvensseffekt: 55dBμA/m@10m</p>
<p>С настоящото TOKAI RIKA CO., LTD. декларира, че този тип радиосъоръжение RI-57BTY е в съответствие с Директива 2014/53/ЕС.</p> <p>Цялостният текст на ЕС декларацията за съответствие може да се намери на следния интернет адрес: http://www.tokai-rika.co.jp/pc</p> <p>Радиочестотна лента: 119 - 135 kHz Максимална радиочестотна мощност: 55dBμA/m@10m</p>

Prin prezenta, TOKAI RIKA CO., LTD. declară că tipul de echipamente radio RI-57BTY este în conformitate cu Directiva 2014/53/UE.

Textul integral al declarației UE de conformitate este disponibil la următoarea adresă internet:

<http://www.tokai-rika.co.jp/pc>

Banda de frecvență: 119 - 135 kHz

Puterea maximă de radiofrecvență: 55dB μ A/m@10m

Ovime TOKAI RIKA CO., LTD. potvrđuje da je radio-oprema tipa RI-57BTY u skladu sa Direktivom 2014/53/EU.

Potpuni tekst EU deklaracije o usaglašenosti dostupan je na slijedećoj internet adresi:

<http://www.tokai-rika.co.jp/pc>

Frekvencijski opseg: 119 - 135 kHz

Maksimalna radio-frekvencijska snaga: 55dB μ A/m@10m

Me anë të këtij dokumenti, TOKAI RIKA CO., LTD. deklaroi se tipi i radiopajisjes RI-57BTY është në përputhje me Direktivën 2014/53/EU.

Teksti i plotë i deklaratës së konformitetit të Bashkimit Evropian është i disponueshëm në adresën e mëposhtme të internetit:

<http://www.tokai-rika.co.jp/pc>

Brezi i frekuencës: 119 - 135 kHz

Fuqia maksimale e radiofrekuencës: 55dB μ A/m@10m

<p>TOKAI RIKA CO., LTD. ovime izjavljuje da je radijska oprema tipa RI-57BTY u skladu s Direktivom 2014/53/EU.</p> <p>Cjeloviti tekst EU izjave o sukladnosti dostupan je na sljedećoj internetskoj adresi: http://www.tokai-rika.co.jp/pc</p> <p>Frekvencijski pojas: 119 - 135 kHz Maksimalna RF snaga: 55dBμA/m@10m</p>
<p>Ovim TOKAI RIKA CO., LTD. potvrđuje da je radio-oprema tipa RI-57BTY u skladu sa Direktivom 2014/53/EU.</p> <p>Potpuni tekst EU deklaracije o usaglašenosti dostupan je na sledećoj internet adresi: http://www.tokai-rika.co.jp/pc</p> <p>Frekventni opseg: 119 - 135 kHz Maksimalna radio-frekventna snaga: 55dBμA/m@10m</p>
<p>TOKAI RIKA CO., LTD., işbu belgeyle telsiz cihazı türünün RI-57BTY 2014/53/EU nolu Direktif ile uyumlu olduğunu beyan etmektedir.</p> <p>AB uygunluk beyanının tam metnine aşağıdaki internet adresinden ulaşabilirsiniz: http://www.tokai-rika.co.jp/pc</p> <p>Frekans bandı: 119 - 135 kHz Maksimum radyo frekans gücü: 55dBμA/m@10m</p>
<p></p> <p>Address: 3-260 Toyota, Oguchi-cho, Niwa-gun, Aichi 480-0195, Japan</p>

► For vehicles sold in Ukraine

Справжнім TOKAI RIKAI CO., LTD. заявляє, що тип радіообладнання RI-57BTU відповідає Технічному регламенту радіообладнання;

КАБІНЕТ МІНІСТРІВ УКРАЇНИ ПОСТАНОВА №.355

Повний текст декларації про відповідність доступний на веб-сайті за такою адресою:

<http://www.tokai-rika.co.jp/pc>

Діапазон частот : 119 - 135 kHz

Максимальна потужність радіочастотного випромінювання :
55dBμA/m @10m



Адреса: 3-260 Toyota, Oguchi-cho, Niwa-gun, Aichi 480-0195,
Japan

► For vehicles sold in Serbia



Wireless remote control■ **Wireless tuner**

Hereby, TOKAI RIKA CO., LTD. declares that the radio equipment type BH3AV is in compliance with Directive 2014/53/EU.

The full text of the EU declaration of conformity is available at the following internet address:

<http://www.tokai-rika.co.jp/pc>

TOKAI RIKA CO., LTD. vakuuttaa, että radiolaitetyyppi BH3AV on direktiivin 2014/53/EU mukainen.

EU-vaatimustenmukaisuusvakuutuksen täysimittainen teksti on saatavilla seuraavassa internetosoitteessa:

<http://www.tokai-rika.co.jp/pc>

Hierbij verklaar ik, TOKAI RIKA CO., LTD., dat het type radioapparatuur BH3AV conform is met Richtlijn 2014/53/EU.

De volledige tekst van de EU-conformiteitsverklaring kan worden geraadpleegd op het volgende internetadres:

<http://www.tokai-rika.co.jp/pc>

Le soussigné, TOKAI RIKA CO., LTD., déclare que l'équipement radioélectrique du type BH3AV est conforme à la directive 2014/53/UE.

Le texte complet de la déclaration UE de conformité est disponible à l'adresse internet suivante:

<http://www.tokai-rika.co.jp/pc>

Härmed försäkrar TOKAI RIKA CO., LTD. att denna typ av radioutrustning BH3AV överensstämmer med direktiv 2014/53/EU.

Den fullständiga texten till EU-försäkran om överensstämmelse finns på följande webbadress:

<http://www.tokai-rika.co.jp/pc>

Hermed erklærer TOKAI RIKA CO., LTD., at radioudstyrstypen BH3AV er i overensstemmelse med direktiv 2014/53/EU.

EU-overensstemmelseserklæringens fulde tekst kan findes på følgende internetadresse:

<http://www.tokai-rika.co.jp/pc>

Hiermit erklärt TOKAI RIKA CO., LTD., dass der Funkanlagentyp BH3AV der Richtlinie 2014/53/EU entspricht.

Der vollständige Text der EU-Konformitätserklärung ist unter der folgenden Internetadresse verfügbar:

<http://www.tokai-rika.co.jp/pc>

Με την παρούσα ο/η TOKAI RIKA CO., LTD., δηλώνει ότι ο ραδιοεξοπλισμός BH3AV πληροί την οδηγία 2014/53/ΕΕ.

Το πλήρες κείμενο της δήλωσης συμμόρφωσης ΕΕ διατίθεται στην ακόλουθη ιστοσελίδα στο διαδίκτυο:

<http://www.tokai-rika.co.jp/pc>

Il fabbricante, TOKAI RIKA CO., LTD., dichiara che il tipo di apparecchiatura radio BH3AV è conforme alla direttiva 2014/53/UE.

Il testo completo della dichiarazione di conformità UE è disponibile al seguente indirizzo Internet:

<http://www.tokai-rika.co.jp/pc>

Por la presente, TOKAI RIKA CO., LTD. declara que el tipo de equipo radioeléctrico BH3AV es conforme con la Directiva 2014/53/UE.

El texto completo de la declaración UE de conformidad está disponible en la dirección Internet siguiente:

<http://www.tokai-rika.co.jp/pc>

O(a) abaixo assinado(a) TOKAI RIKA CO., LTD. declara que o presente tipo de equipamento de rádio BH3AV está em conformidade com a Diretiva 2014/53/UE.

O texto integral da declaração de conformidade está disponível no seguinte endereço de Internet:

<http://www.tokai-rika.co.jp/pc>

B'dan, TOKAI RIKA CO., LTD., niddikjara li dan it-tip ta' tagħmir tar-radju BH3AV huwa konformi mad-Direttiva 2014/53/UE.

It-test kollu tad-dikjarazzjoni ta' konformità tal-UE huwa disponibbli f'dan l-indirizz tal-Internet li ġej:

<http://www.tokai-rika.co.jp/pc>

Käesolevaga deklareerib TOKAI RIKA CO., LTD., et käesolev raadioseadme tüüp BH3AV vastab direktiivi 2014/53/EL nõuetele.

ELi vastavusdeklaratsiooni täielik tekst on kättesaadav järgmisel internetiaadressil:

<http://www.tokai-rika.co.jp/pc>

TOKAI RIKA CO., LTD. igazolja, hogy a BH3AV típusú rádióberendezés megfelel a 2014/53/EU irányelvnek.

Az EU-megfelelőségi nyilatkozat teljes szövege elérhető a következő internetes címen:

<http://www.tokai-rika.co.jp/pc>

TOKAI RIKA CO., LTD. týmto vyhlasuje, že rádiové zariadenie typu BH3AV je v súlade so smernicou 2014/53/EÚ.

Úplné EÚ vyhlásenie o zhode je k dispozícii na tejto internetovej adrese:

<http://www.tokai-rika.co.jp/pc>

Tímto TOKAI RIKA CO., LTD. prohlašuje, že typ rádiového zařízení BH3AV je v souladu se směrnicí 2014/53/EU.

Úplné znění EU prohlášení o shodě je k dispozici na této internetové adrese:

<http://www.tokai-rika.co.jp/pc>

TOKAI RIKA CO., LTD. potvrdjuje, da je tip radijske opreme BH3AV skladen z Direktivo 2014/53/EU.

Celotno besedilo izjave EU o skladnosti je na voljo na naslednjem spletnem naslovu:

<http://www.tokai-rika.co.jp/pc>

Aš, TOKAI RIKA CO., LTD., patvirtinu, kad radijo įrenginių tipas BH3AV atitinka Direktyvą 2014/53/ES.

Visas ES atitikties deklaracijos tekstas prieinamas šiuo interneto adresu:

<http://www.tokai-rika.co.jp/pc>

Ar šo TOKAI RIKAI CO., LTD. deklarē, ka radioiekārta BH3AV atbilst Direktīvai 2014/53/ES.

Pilns ES atbilstības deklarācijas teksts ir pieejams šādā interneta vietnē:

<http://www.tokai-rika.co.jp/pc>

TOKAI RIKAI CO., LTD. niniešzym oświadcza, że typ urządzenia radiowego BH3AV jest zgodny z dyrektywą 2014/53/UE.

Pełny tekst deklaracji zgodności UE jest dostępny pod następującym adresem internetowym:

<http://www.tokai-rika.co.jp/pc>

TOKAI RIKAI CO., LTD. lýsir því hér með yfir að fjarskiptatækið af gerð BH3AV er í samræmi við tilskipun 2014/53/EU.

Öll ESB-samræmisýfirlýsingin er tiltæk á eftirfarandi vefslóð:

<http://www.tokai-rika.co.jp/pc>

TOKAI RIKAI CO., LTD. erklærer herved at radioutstyrten BH3AV er i samsvar med direktivet 2014/53/EU.

Hele teksten av EU-samsvarserklæringen kan leses på det følgende nettstedet:

<http://www.tokai-rika.co.jp/pc>

С настоящото TOKAI RIKAI CO., LTD. декларира, че този тип радиосъоръжение BH3AV е в съответствие с Директива 2014/53/ЕС.

Цялостният текст на ЕС декларацията за съответствие може да се намери на следния интернет адрес:

<http://www.tokai-rika.co.jp/pc>

Prin prezenta, TOKAI RIKA CO., LTD. declară că tipul de echipamente radio BH3AV este în conformitate cu Directiva 2014/53/UE.

Textul integral al declarației UE de conformitate este disponibil la următoarea adresă internet:

<http://www.tokai-rika.co.jp/pc>

Ovime TOKAI RIKA CO., LTD. potvrđuje da je radio-oprema tipa BH3AV u skladu sa Direktivom 2014/53/EU.

Potpuni tekst EU deklaracije o usaglašenosti dostupan je na slijedećoj internet adresi:

<http://www.tokai-rika.co.jp/pc>

Me anë të këtij dokumenti, TOKAI RIKA CO., LTD. deklaroi se tipi i radiopajisjes BH3AV është në përputhje me Direktivën 2014/53/UE.

Teksti i plotë i deklaratës së konformitetit të Bashkimit Evropian është i disponueshëm në adresën e mëposhtme të internetit:

<http://www.tokai-rika.co.jp/pc>

TOKAI RIKA CO., LTD. ovime izjavljuje da je radijska oprema tipa BH3AV u skladu s Direktivom 2014/53/EU.

Cjeloviti tekst EU izjave o sukladnosti dostupan je na sljedećoj internetskoj adresi:

<http://www.tokai-rika.co.jp/pc>

Ovim TOKAI RIKA CO., LTD. potvrđuje da je radio-oprema tipa BH3AV u skladu sa Direktivom 2014/53/EU.

Potpuni tekst EU deklaracije o usaglašenosti dostupan je na sledećoj internet adresi:

<http://www.tokai-rika.co.jp/pc>

TOKAI RIKA CO., LTD., işbu belgeyle telsiz cihazı türünün BH3AV 2014/53/EU nolu Direktif ile uyumlu olduğunu beyan etmektedir.

AB uygunluk beyanının tam metnine aşağıdaki internet adresinden ulaşabilirsiniz:

<http://www.tokai-rika.co.jp/pc>



Address: 3-260 Toyota, Oguchi-cho, Niwa-gun, Aichi 480-0195, Japan

Receiver Category (EN300 220): 2

► For vehicles sold in Ukraine

Справжнім TOKAI RIKAI CO., LTD. заявляє, що тип радіообладнання ВНЗАУ відповідає Технічному регламенту радіообладнання;

КАБІНЕТ МІНІСТРІВ УКРАЇНИ ПОСТАНОВА №.355

Повний текст декларації про відповідність доступний на веб-сайті за такою адресою:

<http://www.tokai-rika.co.jp/pc>

Категорія приймача: 2



Адреса: 3-260 Toyota, Oguchi-cho, Niwa-gun, Aichi 480-0195, Japan

■ Wireless transmitter

Hereby, TOKAI RIKA CO., LTD. declares that the radio equipment type B3E2F2R is in compliance with Directive 2014/53/EU.

The full text of the EU declaration of conformity is available at the following internet address:

<http://www.tokai-rika.co.jp/pc>

Frequency band: 433.050 - 434.790 MHz

Maximum radio-frequency power: 10mW (ERP)

TOKAI RIKA CO., LTD. vakuuttaa, että radiolaitetyyppi B3E2F2R on direktiivin 2014/53/EU mukainen.

EU-vaatimustenmukaisuusvakuutuksen täysimittainen teksti on saatavilla seuraavassa internetosoitteessa:

<http://www.tokai-rika.co.jp/pc>

Radiotaajuus: 433.050 - 434.790 MHz

suurin mahdollinen lähetysteho: 10mW (ERP)

Hierbij verklaar ik, TOKAI RIKA CO., LTD., dat het type radioapparatuur B3E2F2R conform is met Richtlijn 2014/53/EU.

De volledige tekst van de EU-conformiteitsverklaring kan worden geraadpleegd op het volgende internetadres:

<http://www.tokai-rika.co.jp/pc>

Frequentieband: 433.050 - 434.790 MHz

Maximaal radiofrequentievermogen: 10mW (ERP)

Le soussigné, TOKAI RIKA CO., LTD., déclare que l'équipement radioélectrique du type B3E2F2R est conforme à la directive 2014/53/UE.

Le texte complet de la déclaration UE de conformité est disponible à l'adresse internet suivante:

<http://www.tokai-rika.co.jp/pc>

Bande de fréquences: 433.050 - 434.790 MHz

Puissance de radiofréquence maximale: 10mW (ERP)

Härmed försäkrar TOKAI RIKA CO., LTD. att denna typ av radioutrustning B3E2F2R överensstämmer med direktiv 2014/53/EU.

Den fullständiga texten till EU-försäkran om överensstämmelse finns på följande webbadress:

<http://www.tokai-rika.co.jp/pc>

Frekvensband: 433.050 - 434.790 MHz

Maximal radiofrekvensseffekt: 10mW (ERP)

Hermed erklærer TOKAI RIKA CO., LTD., at radioudstyrstypen B3E2F2R er i overensstemmelse med direktiv 2014/53/EU.

EU-overensstemmelseserklæringens fulde tekst kan findes på følgende internetadresse:

<http://www.tokai-rika.co.jp/pc>

Frekvensbånd: 433.050 - 434.790 MHz
Maksimal radiofrekvens effekt: 10mW (ERP)

Hiermit erklärt TOKAI RIKA CO., LTD., dass der Funkanlagentyp B3E2F2R der Richtlinie 2014/53/EU entspricht.

Der vollständige Text der EU-Konformitätserklärung ist unter der folgenden Internetadresse verfügbar:

<http://www.tokai-rika.co.jp/pc>

Frequenzband: 433.050 - 434.790 MHz
Abgestrahlte maximale Sendeleistung: 10mW (ERP)

Με την παρούσα ο/η TOKAI RIKA CO., LTD., δηλώνει ότι ο ραδιοεξοπλισμός B3E2F2R πληροί την οδηγία 2014/53/ΕΕ.

Το πλήρες κείμενο της δήλωσης συμμόρφωσης ΕΕ διατίθεται στην ακόλουθη ιστοσελίδα στο διαδίκτυο:

<http://www.tokai-rika.co.jp/pc>

Ζώνη συχνοτήτων: 433.050 - 434.790 MHz
Μέγιστη ισχύς ραδιοσυχνότητας: 10mW (ERP)

Il fabbricante, TOKAI RIKA CO., LTD., dichiara che il tipo di apparecchiatura radio B3E2F2R è conforme alla direttiva 2014/53/UE.

Il testo completo della dichiarazione di conformità UE è disponibile al seguente indirizzo Internet:

<http://www.tokai-rika.co.jp/pc>

Banda di frequenza: 433.050 - 434.790 MHz
Potenza massima radiofrequenza: 10mW (ERP)

Por la presente, TOKAI RIKA CO., LTD. declara que el tipo de equipo radioeléctrico B3E2F2R es conforme con la Directiva 2014/53/UE.

El texto completo de la declaración UE de conformidad está disponible en la dirección Internet siguiente:

<http://www.tokai-rika.co.jp/pc>

Banda de frecuencia: 433.050 - 434.790 MHz
Potencia máxima de radiofrecuencia: 10mW (ERP)

O(a) abaixo assinado(a) TOKAI RIKA CO., LTD. declara que o presente tipo de equipamento de rádio B3E2F2R está em conformidade com a Diretiva 2014/53/UE.

O texto integral da declaração de conformidade está disponível no seguinte endereço de Internet:

<http://www.tokai-rika.co.jp/pc>

Banda de frequência: 433.050 - 434.790 MHz
Potência máxima de radiofrequências: 10mW (ERP)

<p>B'dan, TOKAI RIKA CO., LTD., niddikjara li dan it-tip ta' tagħmir tar-radju B3E2F2R huwa konformi mad-Direttiva 2014/53/UE.</p> <p>It-test kollu tad-dikjarazzjoni ta' konformità tal-UE huwa disponibbli f'dan l-indirizz tal-Internet li ġej: http://www.tokai-rika.co.jp/pc</p> <p>Tiċnisvið: 433.050 - 434.790 MHz Hámarks útvarpsbylgjutíðni: 10mW (ERP)</p>
<p>Käesolevaga deklareerib TOKAI RIKA CO., LTD., et käesolev raadioseadme tüüp B3E2F2R vastab direktiivi 2014/53/EL nõuetele.</p> <p>ELi vastavusdeklaratsiooni täielik tekst on kättesaadav järgmisel internetiaadressil: http://www.tokai-rika.co.jp/pc</p> <p>Sagedusriba: 433.050 - 434.790 MHz Maksimaalne saatevõimsus: 10mW (ERP)</p>
<p>TOKAI RIKA CO., LTD. igazolja, hogy a B3E2F2R típusú rádióberendezés megfelel a 2014/53/EU irányelvnek.</p> <p>Az EU-megfelelőségi nyilatkozat teljes szövege elérhető a következő internetes címen: http://www.tokai-rika.co.jp/pc</p> <p>Frekvenciasáv: 433.050 - 434.790 MHz Maximális jelerősség: 10mW (ERP)</p>
<p>TOKAI RIKA CO., LTD. týmto vyhlasuje, že rádiové zariadenie typu B3E2F2R je v súlade so smernicou 2014/53/EÚ.</p> <p>Úplné EÚ vyhlásenie o zhode je k dispozícii na tejto internetovej adrese: http://www.tokai-rika.co.jp/pc</p> <p>Frekvenčné pásmo: 433.050 - 434.790 MHz Maximálny rádiový výkon: 10mW (ERP)</p>

<p>Tímto TOKAI RIKA CO., LTD. prohlašuje, že typ rádiového zařízení B3E2F2R je v souladu se směrnicí 2014/53/EU.</p> <p>Úplné znění EU prohlášení o shodě je k dispozici na této internetové adrese: http://www.tokai-rika.co.jp/pc</p> <p>Kmitočtové pásmo: 433.050 - 434.790 MHz Maximální radiofrekvenční výkon: 10mW (ERP)</p>
<p>TOKAI RIKA CO., LTD. potvrzuje, da je tip radijske opreme B3E2F2R skladen z Direktivo 2014/53/EU.</p> <p>Celotno besedilo izjave EU o skladnosti je na voljo na naslednjem spletnem naslovu: http://www.tokai-rika.co.jp/pc</p> <p>Frekvenčni pas: 433.050 - 434.790 MHz Največja moč radijske frekvence: 10mW (ERP)</p>
<p>Aš, TOKAI RIKA CO., LTD., patvirtinu, kad radijo įrenginių tipas B3E2F2R atitinka Direktyvą 2014/53/ES.</p> <p>Visas ES atitikties deklaracijos tekstas prieinamas šiuo interneto adresu: http://www.tokai-rika.co.jp/pc</p> <p>Dažnių juosta: 433.050 - 434.790 MHz Didžiausia radijo dažnių galia: 10mW (ERP)</p>
<p>Ar šo TOKAI RIKA CO., LTD. deklarė, ka radioiekārta B3E2F2R atbilst Direktīvai 2014/53/ES.</p> <p>Pilns ES atbilstības deklarācijas teksts ir pieejams šādā interneta vietnē: http://www.tokai-rika.co.jp/pc</p> <p>Frekvenču josla: 433.050 - 434.790 MHz Maksimālā radiofrekvenču jauda: 10mW (ERP)</p>

<p>TOKAI RIKA CO., LTD. niniejszym oświadcza, że typ urządzenia radiowego B3E2F2R jest zgodny z dyrektywą 2014/53/UE.</p> <p>Pełny tekst deklaracji zgodności UE jest dostępny pod następującym adresem internetowym: http://www.tokai-rika.co.jp/pc</p> <p>Zakres częstotliwości: 433.050 - 434.790 MHz Maksymalna moc częstotliwości radiowej: 10mW (ERP)</p>
<p>TOKAI RIKA CO., LTD. lýsir því hér með yfir að fjarskiptatækið af gerð B3E2F2R er í samræmi við tilskipun 2014/53/EU.</p> <p>Öll ESB-samræmisýfirlýsingin er tiltæk á eftirfarandi vefslóð: http://www.tokai-rika.co.jp/pc</p> <p>Tíðnisvið: 433.050 - 434.790 MHz Hámarks útvarpsbylgjutiðni: 10mW (ERP)</p>
<p>TOKAI RIKA CO., LTD. erklærer herved at radioutstyrtypen B3E2F2R er i samsvar med direktivet 2014/53/EU.</p> <p>Hele teksten av EU-samsvarserklæringen kan leses på det følgende nettstedet: http://www.tokai-rika.co.jp/pc</p> <p>Frekvensbånd: 433.050 - 434.790 MHz Maksimal radiofrekvensseffekt: 10mW (ERP)</p>
<p>С настоящото TOKAI RIKA CO., LTD. декларира, че този тип радиосъоръжение B3E2F2R е в съответствие с Директива 2014/53/ЕС.</p> <p>Цялостният текст на ЕС декларацията за съответствие може да се намери на следния интернет адрес: http://www.tokai-rika.co.jp/pc</p> <p>Радиочестотна лента: 433.050 - 434.790 MHz Максимална радиочестотна мощност: 10mW (ERP)</p>

Prin prezenta, TOKAI RIKA CO., LTD. declară că tipul de echipamente radio B3E2F2R este în conformitate cu Directiva 2014/53/UE.

Textul integral al declarației UE de conformitate este disponibil la următoarea adresă internet:

<http://www.tokai-rika.co.jp/pc>

Banda de frecvență: 433.050 - 434.790 MHz

Puterea maximă de radiofrecvență: 10mW (ERP)

Ovime TOKAI RIKA CO., LTD. potvrđuje da je radio-oprema tipa B3E2F2R u skladu sa Direktivom 2014/53/EU.

Potpuni tekst EU deklaracije o usaglašenosti dostupan je na slijedećoj internet adresi:

<http://www.tokai-rika.co.jp/pc>

Frekvencijski opseg: 433.050 - 434.790 MHz

Maksimalna radio-frekvencijska snaga: 10mW (ERP)

Me anë të këtij dokumenti, TOKAI RIKA CO., LTD. deklaron se tipi i radiopajisjes B3E2F2R është në përputhje me Direktivën 2014/53/EU.

Teksti i plotë i deklaratës së konformitetit të Bashkimit Evropian është i disponueshëm në adresën e mëposhtme të internetit:

<http://www.tokai-rika.co.jp/pc>

Brezi i frekuencës: 433.050 - 434.790 MHz

Fuqia maksimale e radiofrekuencës: 10mW (ERP)

<p>TOKAI RIKA CO., LTD. ovime izjavljuje da je radijska oprema tipa B3E2F2R u skladu s Direktivom 2014/53/EU.</p> <p>Cjeloviti tekst EU izjave o sukladnosti dostupan je na sljedećoj internetskoj adresi: http://www.tokai-rika.co.jp/pc</p> <p>Frekvencijski pojas: 433.050 - 434.790 MHz Maksimalna RF snaga: 10mW (ERP)</p>
<p>Ovim TOKAI RIKA CO., LTD. potvrđuje da je radio-oprema tipa B3E2F2R u skladu sa Direktivom 2014/53/EU.</p> <p>Potpuni tekst EU deklaracije o usaglašenosti dostupan je na sledećoj internet adresi: http://www.tokai-rika.co.jp/pc</p> <p>Frekventni opseg: 433.050 - 434.790 MHz Maksimalna radio-frekventna snaga: 10mW (ERP)</p>
<p>TOKAI RIKA CO., LTD., işbu belgeyle telsiz cihazı türünün B3E2F2R 2014/53/EU nolu Direktif ile uyumlu olduğunu beyan etmektedir.</p> <p>AB uygunluk beyanının tam metnine aşağıdaki internet adresinden ulaşabilirsiniz: http://www.tokai-rika.co.jp/pc</p> <p>Frekans bandı: 433.050 - 434.790 MHz Maksimum radyo frekans gücü: 10mW (ERP)</p>
<p></p> <p>Address: 3-260 Toyota, Oguchi-cho, Niwa-gun, Aichi 480-0195, Japan</p>

<p>⚠: This mark is a safety/warning mark.</p> <ul style="list-style-type: none"> • Do not ingest battery. <p>Chemical Burn Hazard</p> <ul style="list-style-type: none"> • This product contains a coin / button cell battery. • If the coin / button cell battery is swallowed, it can cause severe internal burns in just 2 hours and can lead to death. • Keep new and used batteries away from children. • If the battery compartment does not close securely, stop using the product and keep it away from children. • If you think batteries might have been swallowed or placed inside any part of the body, seek immediate medical attention. <p>CAUTION</p> <ul style="list-style-type: none"> • Risk of explosion if the battery is replaced by an incorrect type. • Replace battery with the same type. <p>CAUTION</p> <ul style="list-style-type: none"> • Risk of explosion or the leakage of flammable liquid or gas. <ul style="list-style-type: none"> • Do not use in /store in /bring into environment of extremely high temperature or extremely low pressure due to the very high altitude. • Do not attempt to burn, crush, or cut used battery.
<p>⚠ : Tämä on turva-/varoituserkki.</p> <ul style="list-style-type: none"> •Paristoa ei saa laittaa suuhun. <p>Kemiallisen palovamman vaara</p> <ul style="list-style-type: none"> •Laitteessa on kolikko-/nappiparisto. •Elimistöön joutunut kolikko-/nappiparisto voi aiheuttaa vakavia sisäisiä palovammoja vain 2 tunnissa, jolloin seurauksena voi olla hengen menetys. •Uudet ja käytetyt paristot on pidettävä poissa lasten ulottuvilta. •Jos paristolokero ei sulkeudu kunnolla, laitteen käyttö on lopetettava, ja laite on pidettävä poissa lasten ulottuvilta. •Jos on syytä epäillä, että paristo on nielaistu tai muuten päässyt elimistöön, ota välittömästi yhteyttä lääkäriin. <p>TÄRKEÄ HUOMAUTUS</p> <ul style="list-style-type: none"> •Käytetyn pariston vaihtaminen tyypiltään väärään voi aiheuttaa räjähdysvaaran. •Vaihda paristo tyypiltään samanlaiseen. <p>TÄRKEÄ HUOMAUTUS</p> <ul style="list-style-type: none"> •Räjähdysvaara tai syttyvän nesteen tai kaasun vuotovaara. <ul style="list-style-type: none"> •Ei saa käyttää/säilyttää/tuoda lämpötilaltaan tai merenpinnasta mitattuna erittäin korkeaan ympäristöön, jossa ilmanpaine on erittäin alhainen. •Käytettyä paristoa ei saa polttaa, murskata tai halkaista.

<p>⚠ : Dit teken is een veiligheids-/waarschuwingsteken.</p> <ul style="list-style-type: none"> • Slik de batterij niet in. <p>Risico op chemische brandwonden</p> <ul style="list-style-type: none"> • Dit product bevat een munt-/knoopcelbatterij. • Als de munt-/knoopcelbatterij wordt ingeslikt, kan het al binnen 2 uur ernstige interne brandwonden veroorzaken en de dood tot gevolg hebben. • Houd nieuwe en gebruikte batterijen buiten bereik van kinderen. • Als het batterijcompartiment niet goed sluit, stop dan met het gebruik van het product en houd het buiten bereik van kinderen. • Als u denkt dat batterijen zijn ingeslikt of in enig deel van het lichaam zijn gestopt, roep dan onmiddellijk medische hulp in. <p>VOORZICHTIG</p> <ul style="list-style-type: none"> • Er bestaat een risico op ontploffing als de batterij wordt vervangen door een verkeerd type. • Vervang de batterij door een van hetzelfde type. <p>VOORZICHTIG</p> <ul style="list-style-type: none"> • Er bestaat een risico op ontploffing of lekkage van brandbare vloeistof of gas. <ul style="list-style-type: none"> • Niet gebruiken in/bewaren in/meenemen naar een omgeving met extreem hoge temperatuur of met extreem lage druk als gevolg van zeer grote hoogte. • Een gebruikte batterij niet verbranden, platdrukken, of doorsnijden.
<p>⚠ : Ce pictogramme est une marque de sécurité/avertissement.</p> <ul style="list-style-type: none"> • Ne pas ingérer la pile. <p>Risques de brûlure chimique</p> <ul style="list-style-type: none"> • Ce produit contient une pile bouton. • Si la pile bouton est avalée, elle peut causer de graves brûlures internes en seulement 2 heures et peut entraîner la mort. • Conservez les piles neuves et usagées hors de portée des enfants. • Si le compartiment de la pile ne ferme pas correctement, cessez d'utiliser le produit et conservez-le hors de portée des enfants. • Si vous pensez que des piles ont pu être avalées ou placées à l'intérieur d'une partie du corps, consultez immédiatement un médecin. <p>AVERTISSEMENT</p> <ul style="list-style-type: none"> • Risque d'explosion si la pile est remplacée par un type incorrect. • Remplacez la pile par une pile du même type. <p>AVERTISSEMENT</p> <ul style="list-style-type: none"> • Risque d'explosion ou de fuite de liquide ou de gaz inflammable. <ul style="list-style-type: none"> • Ne jamais utiliser, stocker, placer dans un environnement à la température extrêmement élevée ou à la pression extrêmement basse en raison d'une très haute altitude. • Ne jamais essayer de brûler, écraser ou couper des piles usagées.

⚠: Det här märket är ett säkerhets-/varningsmärke.

- Förtär inte batteriet.

Risk för kemisk brännskada

- Den här produkten innehåller ett mynt-/knappbatteri.
- Om mynt-/knappbatteriet sväljs kan det orsaka allvarliga interna brännskador på bara två timmar, vilket kan leda till dödsfall.
- Håll nya och använda batterier borta från barn.
- Om batterifacket inte stängs ordentligt, sluta använda produkten och håll den undan från barn.
- Om du misstänker att batterier har svalts eller placerats inuti någon del av kroppen, sök omedelbart läkarvård.

VARNING

- Risk för explosion om batteriet byts ut mot ett av fel typ.
- Byt ut batteriet mot ett av samma typ.

VARNING

- Risk för explosion eller läckage av brandfarliga vätskor och gaser.

- Använd inte, förvara inte och ta inte in i miljö med extremt hög temperatur eller extremt lågt tryck p.g.a. hög höjd.

- Försök inte bränna, krossa eller skära använt batteri.

⚠ : Dette mærke er et sikkerheds-/advarselsmærke.

- Batteriet må ikke indtages.

Fare for kemisk forbrænding

- Dette produkt indeholder et mønt-/knapcellebatteri.
- Hvis mønt-/knapcellebatteriet sluges, kan det medføre alvorlige indre forbrændinger i løbet af kun 2 timer og kan føre til dødsfald.
- Opbevar nye og brugte batterier utilgængeligt for børn.
- Hvis batterirummet ikke kan lukkes ordentligt, skal du indstille brugen af produktet og opbevare det utilgængeligt for børn.
- Hvis du har mistanke om, at der måske er blevet slugt batterier, eller batterier på anden måde er kommet ind i kroppen, skal du øjeblikkeligt søge lægehjælp.

FORSIGTIG



- Risiko for eksplosion, hvis batteriet udskiftes med en forkert type.
- Udskift batteriet med et batteri af samme type.

FORSIGTIG

- Risiko for eksplosion eller lækage af brændbar væske eller gas.

- Må ikke anvendes på/opbevares på/tages med til meget varme steder eller steder med meget lavt tryk som følge af ekstreme højder.

- Forsøg ikke at brænde, knuse eller adskille brugte batterier.

<p>: Dieses Symbol ist ein Sicherheits-/Warnsymbol.</p> <ul style="list-style-type: none"> · Verschlucken Sie die Batterie nicht. <p>Verätzungsgefahr</p> <ul style="list-style-type: none"> · Dieses Produkt enthält eine Knopfzellenbatterie. · Falls die Knopfzellenbatterie verschluckt wird, kann dies innerhalb von nur 2 Stunden schwere innere Verätzungen verursachen und zum Tode führen. · Halten Sie neue und gebrauchte Batterien von Kindern fern. · Falls sich das Batteriefach nicht sicher schließen lässt, stellen Sie die Verwendung des Produkts ein und halten Sie es von Kindern fern. · Falls Sie glauben, dass Batterien eventuell verschluckt oder in einen Teil des Körpers eingeführt worden sind, begeben Sie sich sofort in ärztliche Behandlung. <p>ACHTUNG</p> <ul style="list-style-type: none"> · Es besteht Explosionsgefahr, falls die Batterie durch eine Batterie der falschen Art ersetzt wird. · Ersetzen Sie Batterien nur durch die gleiche Art. <p>ACHTUNG</p> <ul style="list-style-type: none"> · Es besteht Explosionsgefahr oder die Gefahr eines Austritts von brennbarer Flüssigkeit oder entzündlichem Gas. · Das Produkt darf nicht in Umgebungen mit hohen Temperaturen oder extrem niedrigem Luftdruck aufgrund von extremen Höhenlagen verwendet / aufbewahrt / gebracht werden. · Versuchen Sie nicht, gebrauchte Batterien zu verbrennen, zu zerstoßen oder zu schneiden.
<p>: Το σήμα αυτό είναι ένα σήμα ασφαλείας/προειδοποίησης.</p> <ul style="list-style-type: none"> · Μην καταπίνετε την μπαταρία. <p>Κίνδυνος χημικού εγκαύματος</p> <ul style="list-style-type: none"> · Αυτό το προϊόν περιέχει μια μπαταρία σχήματος νομίσματος / κουμπιού. · Αν η μπαταρία σχήματος νομίσματος / κουμπιού καταποθεί, μπορεί να προκαλέσει σοβαρά εσωτερικά εγκαύματα σε μόλις 2 ώρες και μπορεί να επέλθει θάνατος. · Διατηρείτε τις καινούργιες και τις χρησιμοποιημένες μπαταρίες μακριά από παιδιά. · Εάν το διαμέρισμα της μπαταρίας δεν κλείνει καλά, σταματήστε τη χρήση του προϊόντος και κρατήστε το μακριά από παιδιά. · Αν νομίζετε ότι οι μπαταρίες ενδέχεται να έχουν καταποθεί ή τοποθετηθεί μέσα σε οποιοδήποτε μέρος του σώματος, ζητήστε αμέσως ιατρική φροντίδα. <p>ΠΡΟΣΟΧΗ</p> <ul style="list-style-type: none"> · Υπάρχει κίνδυνος έκρηξης εάν η μπαταρία αντικατασταθεί με μπαταρία εσφαλμένου τύπου. · Αντικαταστήστε την μπαταρία με μπαταρία του ίδιου τύπου. <p>ΠΡΟΣΟΧΗ</p> <ul style="list-style-type: none"> · Υπάρχει κίνδυνος έκρηξης ή διαρροής εύφλεκτων υγρών ή αερίων. · Μην χρησιμοποιείτε / αποθηκεύετε / μεταφέρετε το προϊόν σε περιβάλλον με εξαιρετικά υψηλή θερμοκρασία ή εξαιρετικά χαμηλή πίεση λόγω πολύ μεγάλου υψομέτρου. · Μην επιχειρήσετε να κάψετε, να συνθλίψετε ή να κόψετε μια χρησιμοποιημένη μπαταρία.

 : Questo è un simbolo di sicurezza/avvertenza.

- Non ingerire la batteria.

Pericolo di ustioni chimiche

- Questo prodotto contiene una batteria a bottone/moneta.
- Se la batteria a bottone/moneta viene ingerita, può causare gravi ustioni interne in sole 2 ore e provocare la morte.
- Tenere le batterie nuove e usate lontano dalla portata dei bambini.
- Se il vano batteria non si chiude in modo saldo, interrompere l'utilizzo del prodotto e tenerlo lontano dalla portata dei bambini.
- Se si ritiene che le batterie siano state ingerite o inserite in qualsiasi parte del corpo, consultare immediatamente un medico.

ATTENZIONE

- Rischio di esplosione in caso di sostituzione della batteria con una di tipo errato.
- Sostituire la batteria con una dello stesso tipo.

ATTENZIONE

- Rischio di esplosione o di perdita di liquidi o gas infiammabili.
- Non utilizzare / immagazzinare / portare in ambienti con temperatura estremamente alta o pressione estremamente alta a causa dell'elevata altitudine.
- Non provare a bruciare, schiacciare o tagliare la batteria usata.

: Este símbolo es un símbolo de seguridad/precaución.

- No ingerir la batería.

Peligro de quemadura química

- Este producto contiene una batería de pila de botón.
- Si se ingiere la batería de pila de botón, esta puede causar graves quemaduras internas en solo 2 horas y puede provocar la muerte.
- Mantenga las baterías nuevas y usadas alejadas de los niños.
- Si el compartimento de la batería no se cierra correctamente, deje de usar el producto y manténgalo alejado de los niños.
- Si cree que las baterías hayan podido ser ingeridas o introducidas en alguna parte del cuerpo, busque inmediatamente atención médica.

ATENCIÓN

- Riesgo de explosión si la batería es reemplazada por una del tipo incorrecto.
- Reemplace la batería por una del mismo tipo.

ATENCIÓN

- Riesgo de explosión o escape de líquido o gas inflamable.
- No usar / almacenar / introducir en un ambiente de temperatura extremadamente alta o de presión extremadamente baja a causa de la alta altitud.
- No intente quemar, aplastar, o cortar la batería usada.

<p>⚠: Esta marca é uma marca de segurança/aviso.</p> <ul style="list-style-type: none"> • Não ingerir a pilha. <p>Perigo de Queimadura Química</p> <ul style="list-style-type: none"> • Este produto contém uma pilha de tipo moeda/botão. • Se a pilha de tipo moeda/botão for engolida, poderá causar queimaduras internas graves em apenas 2 horas e levar à morte. • Manter as pilhas novas e usadas longe de crianças. • Se o compartimento da pilha não se fechar completamente, cessar a utilização do produto e manter fora do alcance das crianças. • Caso seja possível que as pilhas tenham sido engolidas ou colocadas dentro de qualquer parte do corpo, procurar cuidados médicos imediatamente. <p>CUIDADO</p> <ul style="list-style-type: none"> • Risco de explosão se a pilha for substituída por uma de tipo incorreto. • Substituir a pilha por uma do mesmo tipo. <p>CUIDADO</p> <ul style="list-style-type: none"> • Risco de explosão ou fuga de líquidos ou gases inflamáveis. <ul style="list-style-type: none"> • Não utilizar/armazenar/colocar em ambiente de temperatura extremamente alta, ou pressão extremamente baixa devido a altitude muito alta. • Não tentar queimar, esmagar ou cortar a pilha usada.
<p>⚠: Din il-marka hija marka ta' sigurtá/twissija.</p> <ul style="list-style-type: none"> • Tiblax il-batterija. <p>Periklu ta' Ħruq Kimiku</p> <ul style="list-style-type: none"> • Dan il-prodott fih batterija munita / button cell. • Jekk tinbela' l-batterija munita / button cell, tista' tikkawża ħruq intern sever f'temp ta' sagħtejn biss u tista' twassal għall-mewt. • Żomm il-batteriji godda u użati 'l bogħod mit-tfal. • Jekk il-kompartiment tal-batterija ma jagħlaqx sew, waqqaf l-użu tal-prodott u żommu 'l bogħod mit-tfal. • Jekk taħseb li l-batteriji setgħu nbelgħu jew tpoġġew ġewwa xi parti tal-ġisem, fittex attenzjoni medika immedjata. <p>ATTENZJONI</p> <ul style="list-style-type: none"> • Riskju ta' splużjoni jekk il-batterija tiġi ssostitwita b'tip inkorrett. • Ibdel il-batterija bl-istess tip. <p>ATTENZJONI</p> <ul style="list-style-type: none"> • Riskju ta' splużjoni jew trinxija ta' likwidu jew gass f'jammabbli. <ul style="list-style-type: none"> • Tużahx / taħznux / iġġibux f'ambjent ta' temperatura estremament għolja jew pressjoni estremament baxxa minħabba l-altitudni għolja ħafna. • Tippruvax taħraq, tfarrak jew tqatta' l-batteriji użati.

⚠: See märk on ohutus-/hoiatusmärk.

•Ärge patareid alla neelake.

Keemilise põletuse oht

•See toode sisaldab mündi/nööbi tüüpi elemendiga patareid.

•Mündi/nööbi tüüpi elemendiga patarei allaneelamine võib põhjustada raskeid sisemisi põletusi juba 2 tunni jooksul ning võib lõppeda surmaga.

•Hoidke uued ja kasutatud patareid lastele kättesaamatus kohas.

•Kui patareipesa ei sulgu kindlalt, lõpetage toote kasutamine ja hoidke seda lastele kättesaamatus kohas.

•Kui te arvate, et patareid võivad olla alla neelatud või mistahes kehaossa sattunud, pöörduge viivitamatult arsti poole.

ETTEVAATUST

•Plahvatusoht vahetamisel vale tüüpi patareiga.

•Vahetage sama tüüpi patareiga.

ETTEVAATUST

•Plahvatuse või tuleohtliku vedeliku või gaasi lekke oht.

•Ärge kasutage, hoidke ega tooge keskkonda eriti kõrge temperatuuriga või eriti madala rõhuga väga suure kõrguse tõttu merepinnast.

•Ärge üritage põletada, purustada ega lõigata kasutatud patareid.

⚠ : Ez a jelzés biztonsági/figyelmeztető jelzés.

•Ne nyelje le az elemet.

Vegyí anyag okozta égésisérülés-veszély

•Ez a termék gombelemet tartalmaz.

•Amennyiben a gombelemet lenyeli, az mindössze 2 órán belül komoly belső égési sérüléseket okozhat és halálhoz vezethet.

•Az új és használt elemeket tartsa távol a gyermekektől.

•Amennyiben az elemtartó rekesz nem zárható biztonságosan, függessze fel a termék használatát és tartsa gyermekektől távol.

•Amennyiben úgy véli, hogy az elemet lenyelték vagy bármely testrészbe helyezték, haladéktalanul forduljon orvoshoz.

VIGYÁZAT

•Nem megfelelő típusú csereelem használata robbanásveszélyes.

•Az elemcseréhez azonos típusú elemet használjon.

VIGYÁZAT

•Robbanásveszély vagy gyúlékony folyadékok vagy gázok szivárgása.

•Ne használja/ne tárolja/ne helyezze szélsőségesen magas hőmérsékletű környezetbe, és ne tegye ki a nagy magasságokban kialakuló rendkívül alacsony nyomásnak.

•A használt elemet ne kísérelje meg elégetni, összezúzni vagy szétvágni.

<p>⚠ : Toto je bezpečnostná/výstražná značka.</p> <ul style="list-style-type: none"> • Dbajte na to, aby nedošlo k prehltnutiu batérie. <p>Nebezpečenstvo poleptania chemikáliou</p> <ul style="list-style-type: none"> • Tento výrobok obsahuje mincovú/gombíkovú batériu. • Ak dôjde k prehltnutiu mincovej/gombíkovej batérie, už v priebehu 2 hodín môže spôsobiť vážne vnútorné poleptanie a viesť k usmrteniu. • Nové a použité batérie uchovávajte mimo dosahu detí. • Ak sa priestor pre batériu nezatvorí bezpečne, prestaňte používať výrobok a uchovávajte ho mimo dosahu detí. • Ak si myslíte, že mohlo dôjsť k prehltnutiu batérií alebo ich umiestneniu do ktorejkoľvek časti tela, okamžite vyhľadajte lekársku pomoc. <p>UPOZORNENIE</p> <ul style="list-style-type: none"> • Hrozí nebezpečenstvo výbuchu, ak sa batéria vymení za nesprávny typ. • Vymeňte batériu za rovnaký typ. <p>UPOZORNENIE</p> <ul style="list-style-type: none"> • Nebezpečenstvo výbuchu alebo úniku horľavej kvapaliny alebo horľavého plynu. <p>• Nepoužívajte/neskladujte v prostredí/nepřinášajte do prostredia s mimoriadne vysokou teplotou, alebo mimoriadne nízkym tlakom v dôsledku veľmi vysokej nadmorskej výšky.</p> <p>• Nepokúšajte sa spáliť, rozdrviť ani rozrezať použitú batériu.</p>
<p>⚠ : Tento symbol je bezpečnostným/výstražným symbolom.</p> <ul style="list-style-type: none"> • Baterii nepolykejte. <p>Nebezpečí chemických popálenin</p> <ul style="list-style-type: none"> • Tento výrobok obsahuje mincovou/knoflíkovou batériu. • Pokiaľ dojde ke spolknutí mincové/knoflíkové batérie, môže za pouhé 2 hodiny spôsobiť závažné vnútorné popáleniny a v jejich dôsledku prípadne i smrť. • Použité a nové batérie udržiavajte mimo dosah detí. • Pokiaľ nelze prostor pro baterii pevně uzavřít, přestaňte výrobek používat a udržiavte jej mimo dosah dětí. • Pokud si myslíte, že mohlo dojít ke spolknutí baterie nebo jejímu vsunutí dovnitř kterékoliv části těla, okamžitě vyhledejte lékařskou pomoc. <p>UPOZORNĚNÍ</p> <ul style="list-style-type: none"> • Nebezpečí výbuchu v případě výměny baterie za nesprávný druh baterie. • Proto baterii vždy vyměňte za jinou stejného typu. <p>UPOZORNĚNÍ</p> <ul style="list-style-type: none"> • Nebezpečí výbuchu nebo úniku hořlavé kapaliny či plynu. <p>• Nepoužívejte/neskladujte/nepřinášejte je do prostředí s nesmírně vysokou teplotou nebo nesmírně nízkým tlakem zapříčiněným vysokou nadmořskou výškou.</p> <p>• Nesnažte se baterii spálit, rozdrtit či rozříznout.</p>

 : Ta oznaka je varnostna/opozorilna oznaka.

- Ne zaužijte baterije.

Nevarnost kemijske opeklne

- Ta izdelek vsebuje gumbasto baterijo.
- Če se gumbasto baterijo zaužije, lahko to povzroči hude notranje opeklne v le 2 urah in lahko vodi v smrt.
- Nove in rabljene baterije hranite izven dosega otrok.
- Če se predalček za baterijo ne zapira pravilno, prenehajte z uporabo izdelka in ga hranite izven dosega otrok.
- Če sumite, da je morda nekdo zaužil baterijo ali jo dal v kateri koli del telesa, takoj poiščite zdravniško pomoč.

POZOR

- Nevarnost eksplozije, če baterijo zamenjate z baterijo napačne vrste.
- Zamenjajte baterijo z istim tipom.

POZOR

- Tveganje za eksplozijo ali puščanje vnetljivih tekočin ali plinov.
- Ne uporabljajte/shranjujte/prinašajte v okolje izredno visoke temperature ali izredno nizkega tlaka zaradi zelo visoke nadmorske višine.
- Ne poskušajte zažigati, uničiti, ali rezati rabljene baterije.

 : Šis ženklas yra saugos/jspėjamas ženklas.

- Neprarykite baterijos.

Cheminių nudegimų pavojus

- Šiame gaminyje yra monetos/sagos formos baterija.
- Prarijęs monetos/sagos formos bateriją, asmuo per 2 valandas gali patirti sunkius vidinius nudegimus ir netgi mirti.
- Naujas ir panaudotas baterijas laikykite vaikams nepasiekiamoje vietoje.
- Jei baterijų skyrelio nepavyksta tvirtai uždaryti, nebenaudokite gaminio ir laikykite jį vaikams nepasiekiamoje vietoje.
- Jei manote, kad baterijos buvo prarytos arba pateko į kūną, nedelsdami kreipkitės į gydytoją.

PERSPĖJIMAS

- Bateriją pakeitus netinkamo tipo baterija, kyla sprogdimo pavojus.
- Pakeiskite seną bateriją tik to paties tipo nauja baterija.

PERSPĖJIMAS

- Sprogdimo arba degių skysčių ar dujų nuotėkio pavojus.
- Negalima naudoti/laikyti/turėti labai aukštos temperatūros arba labai dideliame aukštyje esančioje itin žemo slėgio aplinkoje.
- Naudotas baterijos nebandykite deginti, ardyti ar perpjauti.

<p>⚠ : Šī zīme ir drošības/brīdinājuma zīme.</p> <ul style="list-style-type: none"> • Nenorijiet bateriju. <p>Kīmisku apdegumu briesmas</p> <ul style="list-style-type: none"> • Šis izstrādājums satur tabletes tipa bateriju. • Ja ir norīta tabletes tipa baterija, tā 2 stundu laikā var radīt smagus apdegumus un izraisīt nāvi. • Jaunas un lietotas baterijas uzglabājiet bērniem nepieejamā vietā. • Ja bateriju nodalījumu nevar droši aizvērt, pārtrauciet lietot izstrādājumu un novietojiet to bērniem nepieejamā vietā. • Ja jūsuprāt baterijas ir norītas vai ievietotas kādā ķermeņa daļā, nekavējoties vērsieties pēc medicīniskās palīdzības. <p>UZMANĪBU!</p> <ul style="list-style-type: none"> • Eksplozijas risks, ja baterija tiek nomainīta ar nepareiza tipa bateriju. • Bateriju nomainiet pret tāda paša tipa bateriju. <p>UZMANĪBU!</p> <ul style="list-style-type: none"> • Eksplozijas vai uzliesmojoša šķidruma vai gāzes noplūdes risks. <ul style="list-style-type: none"> • Nelietojiet, neuzglabājiet un neievietojiet vidē ar ļoti augstu temperatūru, kā arī vidē, kur ļoti lielā augstuma virs jūras līmeņa dēļ ir ļoti zems spiediens. • Nemēģiniet sadedzināt, sagraut vai sagriezt nolietoto bateriju.
<p>⚠ : ten symbol oznacza niebezpieczeństwo/ostreżenie.</p> <ul style="list-style-type: none"> • Nie pólkać baterii. <p>Ryzyko oparzenia chemicznego</p> <ul style="list-style-type: none"> • Ten produkt zawiera baterię guzikową. • Połknięta bateria guzikowa może spowodować poważne oparzenia wewnętrzne w czasie jedynie 2 godzin i prowadzić do śmierci. • Przechowywać nowe i zużyte baterie z dala od dzieci. • Jeśli solidne zamknięcie komory baterii jest niemożliwe, zaprzestać użytkowania produktu i przechowywać go w miejscu niedostępnym dla dzieci. • W przypadku podejrzenia, że mogło dojść do połknięcia baterii lub ich umieszczenia w dowolnym otworze ciała, niezwłocznie uzyskać pomoc lekarską. <p>PRZESTROGA</p> <ul style="list-style-type: none"> • Istnieje ryzyko wybuchu, jeśli bateria zostanie zastąpiona baterią niewłaściwego typu. • Wymieniać baterię na baterię tego samego typu. <p>PRZESTROGA</p> <ul style="list-style-type: none"> • Ryzyko wybuchu lub wycieku łatwopalnego płynu lub gazu. <ul style="list-style-type: none"> • Nie używać i nie przechowywać w otoczeniu o skrajnie wysokiej temperaturze lub skrajnie niskim ciśnieniu wynikającym z bardzo dużej wysokości ani nie wnosić do takiego otoczenia. • Nie podejmować prób spalania, zgniecenia lub przecięcia zużytej baterii.

 : Този знак е знак за безопасност/предупреждение.

- Не поглъщайте батерията.

Опасност от химическо изгаряне

- Този продукт съдържа плоска/бутонна батерия.
- Ако плоската/бутонна батерия бъде погълната, тя може да причини тежки вътрешни изгаряния само за 2 часа и може да доведе до смърт.
- Пазете новите и използваните батерии далеч от деца.
- Ако отделението за батериите не се затваря добре, спрете да използвате продукта и го дръжте далеч от деца.
- Ако смятате, че батериите може да са били погълнати или поставени в някоя част на тялото, незабавно потърсете медицинска помощ.

ВНИМАНИЕ

- Опасност от експлозия, ако батерията бъде сменена с неправилен тип.
- Сменете батерията със същия вид.

ВНИМАНИЕ

- Опасност от експлозия или изтичане на запалими течности или газове.
- Не използвайте/съхранявайте/носете в среда с изключително висока температура или изключително ниско налягане, причинено от голямата височина.
- Не се опитвайте да изгаряте, смачквате или режете използваната батерия.

 : Acest marcaj este un marcaj de securitate/avertizare.

- Nu ingerați bateria.

Pericol de arsuri chimice

- Acest produs conține o baterie tip pastilă.
- Dacă bateria tip pastilă este înghițită, aceasta poate cauza arsuri interne grave în numai 2 ore și poate duce la deces.
- Nu lăsați bateriile noi și bateriile uzate la îndemâna copiilor.
- În cazul în care compartimentul bateriei nu se închide bine, încetați utilizarea produsului și nu îl lăsați la îndemâna copiilor.
- Dacă bănuți că este posibil ca bateriile să fi fost înghițite sau introduse în orice parte a corpului, consultați imediat medicul.

ATENȚIE

- Risc de explozie dacă bateria este înlocuită cu un tip incorect.
- Înlocuiți bateria cu una de același tip.

ATENȚIE

- Risc de explozie sau de scurgeri de lichide sau gaze inflamabile.
- Nu utilizați/depozitați într-un mediu cu temperatură extrem de înaltă sau cu presiune extrem de joasă din cauza altitudinii foarte mari.
- Nu încercați să ardeți, să spargeți sau să tăiați bateriile uzate.

⚠ : Ova oznaka je oznaka sigurnosti/upozorenja.

- Nemojte gutati bateriju.

Opasnost od kemijskih opekline

- Ovaj proizvod sadrži novčić/gumb bateriju.
- Ako se novčić/gumb baterija proguta, može uzrokovati ozbiljne unutarnje opekline u samo 2 sata i može dovesti do smrti.
- Držite nove i rabljene baterije izvan dohvata djece.
- Ako se pretinac za baterije ne zatvara sigurno, prestanite koristiti proizvod i držite ga dalje od djece.
- Ako smatrate da su baterije možda progutane ili smještene unutar bilo kojeg dijela tijela, zatražite hitnu medicinsku pomoć.

OPREZ

- Ako je baterija zamijenjena pogrešnim tipom, postoji rizik od eksplozije.
- Zamijenite bateriju s baterijama iste vrste.

OPREZ

- Rizik od eksplozije ili istjecanja zapaljive tekućine ili plina.

- Nemojte koristiti u /pohranjivati u /unijeti u prostoru izuzetno visoke temperature ili izuzetno niskog tlaka zbog visoke nadmorske visine.

- Ne pokušavajte spaliti, lomiti ili rezati istrošenu bateriju.

⚠ : Þetta tákn er öryggis-/aðvörunartákn.

- Gleypið ekki rafhlöðuna.

Hætta á efnabruna

- Þessi vara inniheldur flata rafhlöðu.
- Ef rafhlaðan er gleypst getur hún valdið alvarlegum innvortis brunna á innan við 2 klukkustundum sem getur leitt til dauða.
- Geymið nýjar og notaðar rafhlöður þar sem börn ná ekki til.
- Ef rafhlöðuhólfífið lokast ekki örugglega skal hætta notkun vörunnar og geyma hana þar sem börn ná ekki til.
- Ef þú telur að rafhlöður hafi verið gleypst eða settar inn í eitthvert líkamsop, skaltu hafa samband við lækni tafarlaust.

VARÚÐ

- Hætta á sprengingu ef rafhlöðunni er skipt út fyrir ranga tegund.
- Skiptið rafhlöðunni ávallt út fyrir sömu tegund.

VARÚÐ

- Hætta á sprengingu eða leka á eldfimum vökva eða lofttegundum.

- Má ekki nota/geyma/setja í umhverfi þar sem er afar hár hiti, eða afar lágur þrýstingur vegna mikillar hæðar.

- Ekki reyna að brenna, kremja eða skera notaða rafhlöðu.

 : Dette merket er et sikkerhets-/advarselsmerke.

- Ikke svelg batteriet.

Kjemisk brannfare

- Dette produktet inneholder et mynt-/knappcellebatteri.
- Dersom mynt-/knappcellebatteriet svelges, kan det frembringe alvorlige indre forbrenninger i løpet av kun to timer, og kan være dødelig.
- Hold nye og brukte batterier borte fra barn.
- Lukkes ikke batterirommet sikkert må du stanse å bruke produktet og holde det utenfor barns rekkevidde.
- Oppsøk medisinsk hjelp umiddelbart hvis du tror at batterier kan være svelget eller plassert inne i kroppen.

FORSIKTIG

- Eksplosjonsfare hvis batteriet erstattes med feil type.
- Bytt batteri med samme type.

FORSIKTIG

- Fare for eksplosjon eller lekkasje av brannfarlig væske eller gass.

- Ikke bruk i/oppbevar i/ta med inn i miljø med ekstremt høy temperatur eller ekstremt lavt trykk på grunn av den svært store høyden.

- Ikke forsøk å brenne, knuse eller skjære opp et brukt batteri.

 : Ova oznaka je sigurnosna/upozoravajuća oznaka.

- Nemojte gutati bateriju.

Opasnost od hemijskih opekotina

- Ovaj proizvod sadrži bateriju veličine kovanice/dugmeta.
- Ako se baterija veličine kovanice/dugmeta proguta, može izazvati ozbiljne unutrašnje opekotine za samo 2 sata i može dovesti do smrti.
- Čuvajte nove i korišćene baterije dalje od djece.
- Ako se prostor za baterije ne zatvori dobro, prestanite sa korišćenjem proizvoda i držite ga dalje od djece.
- Ako mislite da su baterije možda progutane ili stavljene u unutrašnjost bilo kog dijela tijela, potražite hitnu medicinsku pomoć.

OPREZ

- Opasnost od eksplozije ako se baterija zamijeni s baterijom pogrešnog tipa.
- Zamijenite bateriju sa baterijom istog tipa.

OPREZ

- Opasnost od eksplozije ili curenja zapaljive tečnosti ili gasa.

- Nemojte koristiti /skladištiti /unositi u okruženje izuzetno visoke temperature ili izuzetno niskog pritiska usljed veoma velike visine.

- Ne pokušavajte da spalite, lomite ili isječete iskorišćenu bateriju.

 : Kjo është shenjë sigurie/paralajmërimi.

• Mos e gëlltisni baterinë.

Rrezik djegieje kimike

• Ky produkt përmban një bateri të hollë në formë monedhe/kopse.

• Nëse bateria e hollë në formë monedhe/kopse gëlltitet, ajo mund të shkaktojë djegie të rënda të brendshme brenda vetëm 2 orëve dhe mund të sjellë vdekjen.

• Mbajini bateritë e reja dhe të përdorura larg nga fëmijët.

• Nëse foleja e baterisë nuk mbyllet mirë, ndaloni përdorimin e produktit dhe mbajeni larg nga fëmijët.

• Nëse mendoni se bateritë mund të jenë gëlltitur ose futur brenda ndonjë pjese trupi, kërkoni menjëherë vëmendjen e mjekut.

KUJDES

• Rrezik shpërthimi nëse bateria zëvendësohet me një lloj të pasaktë.

• Zëvendësojeni baterinë me të njëjtin lloj.

KUJDES

• Rrezik shpërthimi nga rrjedhja e lëngut apo gazit të ndezshëm.

• Mos e përdorni / ruani / sillni në mjedise me temperaturë jashtëzakonisht të lartë ose presion jashtëzakonisht të ulët në lartësi shumë të mëdha.

• Mos u përpiqni të digjni, shtypni ose prisni baterinë e përdorur.

 : Ova oznaka je oznaka za bezbednost/upozorenje.

• Nemojte gutati bateriju.

Opasnost od hemijskih opekotina

• Ovaj proizvod sadrži bateriju u obliku novčića/dugmeta.

• Ako se baterija u obliku novčića/gumba proguta, može da izazove ozbiljne interne opekotine za samo 2 sata i može da dovede do smrti.

• Nove i korišćene baterije čuvajte van domašaja dece.

• Ako se odeljak za bateriju ne zatvori dobro, prestanite da koristite proizvod i čuvajte ga van domašaja dece.

• Ako mislite da su baterije možda progutane ili stavljene unutar bilo kog dela tela, odmah zatražite medicinsku pomoć.

OPREZ

• Rizik od eksplozije ako je baterija zamenjena nepravilnim tipom.

• Zamenite bateriju sa istim tipom.

OPREZ

• Rizik od eksplozije ili curenja zapaljive tečnosti ili gasa.

• Ne koristite/ne čuvajte/ne donosite u sredinu izuzetno visoke temperature ili izuzetno niskog pritiska usled vrlo visoke visine.

• Ne pokušavajte da zapalite, smrvite ili isečete korišćenu bateriju.

⚠ : Bu işaret bir güvenlik/uyarı işaretidir.

• Pili yutmayın.

Kimyasal Yanma Tehlikesi

• Bu üründe bir düğme pil bulunmaktadır.

• Düğme pil yutulursa, sadece 2 saat içinde ağır iç yanıklara neden olabilir ve ölüme yol açabilir.

• Yeni ve kullanılmış pilleri çocuklardan uzak tutun.

• Pil yuvası emniyetli bir şekilde kapanmıyorsa, ürünü kullanmayı bırakın ve çocuklardan uzak tutun.

• Pillerin yutulduğunu veya vücudun herhangi bir parçasının içine yerleştirildiğini düşünüyorsanız, derhal tıbbi yardım alın.

DİKKAT

• Pil yanlış tür bir pille değiştirilirse patlama riski vardır.

• Pili aynı tür pillerle değiştirin.

DİKKAT

• Patlama ya da yanıcı sıvı veya gaz sızıntısı riski vardır.

• Aşırı derecede yüksek sıcaklıktaki veya çok yüksek rakımdan dolayı aşırı derecede düşük basınca sahip ortamlarda kullanmayın /saklamayın veya bu ortamlara götürmeyin.

• Kullanılmış pili yakmaya, ezmeye veya kesmeye çalışmayın.

► For vehicles sold in Ukraine

Справжнім TOKAI RIKA CO., LTD. заявляє, що тип радіообладнання В3Е2F2R відповідає Технічному регламенту радіообладнання;

КАБІНЕТ МІНІСТРІВ УКРАЇНИ ПОСТАНОВА №.355

Повний текст декларації про відповідність доступний на веб-сайті за такою адресою:

<http://www.tokai-rika.co.jp/pc>

Діапазон частот : 433.050 - 434.790 MHz

Максимальна потужність радіочастотного випромінювання : 10 mW(ERP)



Адреса: 3-260 Toyota, Oguchi-cho, Niwa-gun, Aichi 480-0195, Japan



Ця позначка являє собою позначку про необхідність дотримання правил безпеки/застереження.

- Не допускайте проковтування батарейки.

Небезпека хімічного опіку

- Цей виріб містить батарею монетного / таблеткового типу.
- Проковтування батарейки монетного / таблеткового типу може спричинити тяжкі внутрішні опіки всього лише за 2 години і може призвести до смерті.
- Зберігайте нові та використані батарейки подалі від дітей.
- Якщо кришка батарейного відсіку надійно не закривається, припиніть користуватися виробом і зберігайте його подалі від дітей.
- Якщо існує ймовірність проковтування батарейки або її розміщення всередині будь-якої частини тіла, негайно зверніться за медичною допомогою.

ОБЕРЕЖНО

- Ризик вибуху в разі заміни на батарею неналежного типу.
- Замінюйте батарею на батарею такого ж самого типу.

ОБЕРЕЖНО

- Ризик вибуху або витоку горючої рідини або газу.
- Не використовуйте /не зберігайте /не розміщуйте в умовах надзвичайно високої температури або надзвичайно низького тиску через дуже велику висоту над рівнем моря.
- Не намагайтеся спалити, розбити або розрізати використану батарею.

- ▶ For vehicles sold in Serbia



Smart entry & start system

■ Smart tuner

Hereby, TOKAI RIKA CO., LTD. declares that the radio equipment type BH2KV is in compliance with Directive 2014/53/EU.

The full text of the EU declaration of conformity is available at the following internet address:

<http://www.tokai-rika.co.jp/pc>

TOKAI RIKA CO., LTD. vakuuttaa, että radiolaitetyyppi BH2KV on direktiivin 2014/53/EU mukainen.

EU-vaatimustenmukaisuusvakuutuksen täysimittainen teksti on saatavilla seuraavassa internetosoitteessa:

<http://www.tokai-rika.co.jp/pc>

Hierbij verklaar ik, TOKAI RIKA CO., LTD., dat het type radioapparatuur BH2KV conform is met Richtlijn 2014/53/EU.

De volledige tekst van de EU-conformiteitsverklaring kan worden geraadpleegd op het volgende internetadres:

<http://www.tokai-rika.co.jp/pc>

Le soussigné, TOKAI RIKA CO., LTD., déclare que l'équipement radioélectrique du type BH2KV est conforme à la directive 2014/53/UE.

Le texte complet de la déclaration UE de conformité est disponible à l'adresse internet suivante:

<http://www.tokai-rika.co.jp/pc>

Härmed försäkrar TOKAI RIKA CO., LTD. att denna typ av radioutrustning BH2KV överensstämmer med direktiv 2014/53/EU.

Den fullständiga texten till EU-försäkran om överensstämmelse finns på följande webbadress:

<http://www.tokai-rika.co.jp/pc>

Hermed erklærer TOKAI RIKA CO., LTD., at radioudstyrstypen BH2KV er i overensstemmelse med direktiv 2014/53/EU.

EU-overensstemmelseserklæringens fulde tekst kan findes på følgende internetadresse:

<http://www.tokai-rika.co.jp/pc>

Hiermit erkläre TOKAI RIKA CO., LTD., dass der Funkanlagentyp BH2KV der Richtlinie 2014/53/EU entspricht.

Der vollständige Text der EU-Konformitätserklärung ist unter der folgenden Internetadresse verfügbar:

<http://www.tokai-rika.co.jp/pc>

Με την παρούσα ο/η TOKAI RIKA CO., LTD., δηλώνει ότι ο ραδιοεξοπλισμός BH2KV πληροί την οδηγία 2014/53/ΕΕ.

Το πλήρες κείμενο της δήλωσης συμμόρφωσης ΕΕ διατίθεται στην ακόλουθη ιστοσελίδα στο διαδίκτυο:

<http://www.tokai-rika.co.jp/pc>

Il fabbricante, TOKAI RIKA CO., LTD., dichiara che il tipo di apparecchiatura radio BH2KV è conforme alla direttiva 2014/53/UE.

Il testo completo della dichiarazione di conformità UE è disponibile al seguente indirizzo Internet:

<http://www.tokai-rika.co.jp/pc>

Por la presente, TOKAI RIKA CO., LTD. declara que el tipo de equipo radioeléctrico BH2KV es conforme con la Directiva 2014/53/UE.

El texto completo de la declaración UE de conformidad está disponible en la dirección Internet siguiente:

<http://www.tokai-rika.co.jp/pc>

O(a) abaixo assinado(a) TOKAI RIKA CO., LTD. declara que o presente tipo de equipamento de rádio BH2KV está em conformidade com a Diretiva 2014/53/UE.

O texto integral da declaração de conformidade está disponível no seguinte endereço de Internet:

<http://www.tokai-rika.co.jp/pc>

B'dan, TOKAI RIKA CO., LTD., niddikjara li dan it-tip ta' tagħmir tar-radju BH2KV huwa konformi mad-Direttiva 2014/53/UE.

It-test kollu tad-dikjarazzjoni ta' konformità tal-UE huwa disponibbli f'dan l-indirizz tal-Internet li ġej:

<http://www.tokai-rika.co.jp/pc>

Käesolevaga deklareerib TOKAI RIKA CO., LTD., et käesolev raadioseadme tüüp BH2KV vastab direktiivi 2014/53/EL nõuetele.

ELi vastavusdeklaratsiooni täielik tekst on kättesaadav järgmisel internetiaadressil:

<http://www.tokai-rika.co.jp/pc>

TOKAI RIKA CO., LTD. igazolja, hogy a BH2KV típusú rádióberendezés megfelel a 2014/53/EU irányelvnek.

Az EU-megfelelőségi nyilatkozat teljes szövege elérhető a következő internetes címen:

<http://www.tokai-rika.co.jp/pc>

TOKAI RIKA CO., LTD. týmto vyhlasuje, že rádiové zariadenie typu BH2KV je v súlade so smernicou 2014/53/EÚ.

Úplné EÚ vyhlásenie o zhode je k dispozícii na tejto internetovej adrese:

<http://www.tokai-rika.co.jp/pc>

Tímto TOKAI RIKA CO., LTD. prohlašuje, že typ rádiového zařízení BH2KV je v souladu se směrnicí 2014/53/EU.

Úplné znění EU prohlášení o shodě je k dispozici na této internetové adrese:

<http://www.tokai-rika.co.jp/pc>

TOKAI RIKA CO., LTD. potrjuje, da je tip radijske opreme BH2KV skladen z Direktivo 2014/53/EU.

Celotno besedilo izjave EU o skladnosti je na voljo na naslednjem spletnem naslovu:

<http://www.tokai-rika.co.jp/pc>

Aš, TOKAI RIKA CO., LTD., patvirtinu, kad radijo įrenginių tipas BH2KV atitinka Direktyvą 2014/53/ES.

Visas ES atitikties deklaracijos tekstas prieinamas šiuo interneto adresu:

<http://www.tokai-rika.co.jp/pc>

<p>Ar šo TOKAI RIKA CO., LTD. deklarē, ka radioiekārta BH2KV atbilst Direktīvai 2014/53/ES.</p> <p>Pilns ES atbilstības deklarācijas teksts ir pieejams šādā interneta vietnē: http://www.tokai-rika.co.jp/pc</p>
<p>TOKAI RIKA CO., LTD. niniešzym oświadcza, że typ urządzenia radiowego BH2KV jest zgodny z dyrektywą 2014/53/UE.</p> <p>Pełny tekst deklaracji zgodności UE jest dostępny pod następującym adresem internetowym: http://www.tokai-rika.co.jp/pc</p>
<p>TOKAI RIKA CO., LTD. lýsir því hér með yfir að fjarskiptatækið af gerð BH2KV er í samræmi við tilskipun 2014/53/EU.</p> <p>Öll ESB-samræmisýfirlýsingin er tiltæk á eftirfarandi vefslóð: http://www.tokai-rika.co.jp/pc</p>
<p>TOKAI RIKA CO., LTD. erklærer herved at radioutstyrten BH2KV er i samsvar med direktivet 2014/53/EU.</p> <p>Hele teksten av EU-samsvarserklæringen kan leses på det følgende nettstedet: http://www.tokai-rika.co.jp/pc</p>
<p>С настоящото TOKAI RIKA CO., LTD. декларира, че този тип радиосъоръжение BH2KV е в съответствие с Директива 2014/53/ЕС.</p> <p>Цялостният текст на ЕС декларацията за съответствие може да се намери на следния интернет адрес: http://www.tokai-rika.co.jp/pc</p>

Prin prezenta, TOKAI RIKA CO., LTD. declară că tipul de echipamente radio BH2KV este în conformitate cu Directiva 2014/53/UE.

Textul integral al declarației UE de conformitate este disponibil la următoarea adresă internet:

<http://www.tokai-rika.co.jp/pc>

Ovime TOKAI RIKA CO., LTD. potvrđuje da je radio-oprema tipa BH2KV u skladu sa Direktivom 2014/53/EU.

Potpuni tekst EU deklaracije o usaglašenosti dostupan je na slijedećoj internet adresi:

<http://www.tokai-rika.co.jp/pc>

Me anë të këtij dokumenti, TOKAI RIKA CO., LTD. deklararon se tipi i radiopajisjes BH2KV është në përputhje me Direktivën 2014/53/EU.

Teksti i plotë i deklaratës së konformitetit të Bashkimit Evropian është i disponueshëm në adresën e mëposhtme të internetit:

<http://www.tokai-rika.co.jp/pc>

TOKAI RIKA CO., LTD. ovime izjavljuje da je radijska oprema tipa BH2KV u skladu s Direktivom 2014/53/EU.

Cjeloviti tekst EU izjave o sukladnosti dostupan je na sljedećoj internetskoj adresi:

<http://www.tokai-rika.co.jp/pc>

Ovim TOKAI RIKA CO., LTD. potvrđuje da je radio-oprema tipa BH2KV u skladu sa Direktivom 2014/53/EU.

Potpuni tekst EU deklaracije o usaglašenosti dostupan je na sledećoj internet adresi:

<http://www.tokai-rika.co.jp/pc>

TOKAI RIKA CO., LTD., işbu belgeyle telsiz cihazı türünün BH2KV 2014/53/EU nolu Direktif ile uyumlu olduğunu beyan etmektedir.

AB uygunluk beyanının tam metnine aşağıdaki internet adresinden ulaşabilirsiniz:

<http://www.tokai-rika.co.jp/pc>



Address: 3-260 Toyota, Oguchi-cho, Niwa-gun, Aichi 480-0195, Japan

Receiver Category (EN300 220): 2

► For vehicles sold in Ukraine

Справжнім TOKAI RIKAI CO., LTD. заявляє, що тип радіообладнання ВН2KV відповідає Технічному регламенту радіообладнання;

КАБІНЕТ МІНІСТРІВ УКРАЇНИ ПОСТАНОВА №.355

Повний текст декларації про відповідність доступний на веб-сайті за такою адресою:

<http://www.tokai-rika.co.jp/pc>

Категорія приймача: 2



Адреса: 3-260 Toyota, Oguchi-cho, Niwa-gun, Aichi 480-0195, Japan

■ Smart transmitter

Hereby, TOKAI RIKA CO., LTD. declares that the radio equipment type B3H2K2R is in compliance with Directive 2014/53/EU.

The full text of the EU declaration of conformity is available at the following internet address:

<http://www.tokai-rika.co.jp/pc>

Frequency band: 433.050 - 434.790 MHz

Maximum radio-frequency power: 10mW (ERP)

TOKAI RIKA CO., LTD. vakuuttaa, että radiolaitetyyppi B3H2K2R on direktiivin 2014/53/EU mukainen.

EU-vaatimustenmukaisuusvakuutuksen täysimittainen teksti on saatavilla seuraavassa internetosoitteessa:

<http://www.tokai-rika.co.jp/pc>

Radiotaajuus: 433.050 - 434.790 MHz

suurin mahdollinen lähetysteho: 10mW (ERP)

Hierbij verklaar ik, TOKAI RIKA CO., LTD., dat het type radioapparatuur B3H2K2R conform is met Richtlijn 2014/53/EU.

De volledige tekst van de EU-conformiteitsverklaring kan worden geraadpleegd op het volgende internetadres:

<http://www.tokai-rika.co.jp/pc>

Frequentieband: 433.050 - 434.790 MHz

Maximaal radiofrequentievermogen: 10mW (ERP)

Le soussigné, TOKAI RIKA CO., LTD., déclare que l'équipement radioélectrique du type B3H2K2R est conforme à la directive 2014/53/UE.

Le texte complet de la déclaration UE de conformité est disponible à l'adresse internet suivante:

<http://www.tokai-rika.co.jp/pc>

Bande de fréquences: 433.050 - 434.790 MHz

Puissance de radiofréquence maximale: 10mW (ERP)

Härmed försäkrar TOKAI RIKA CO., LTD. att denna typ av radioutrustning B3H2K2R överensstämmer med direktiv 2014/53/EU.

Den fullständiga texten till EU-försäkran om överensstämmelse finns på följande webbadress:

<http://www.tokai-rika.co.jp/pc>

Frekvensband: 433.050 - 434.790 MHz

Maximal radiofrekvensseffekt: 10mW (ERP)

Hermed erklærer TOKAI RIKA CO., LTD., at radioudstyrstypen B3H2K2R er i overensstemmelse med direktiv 2014/53/EU.

EU-overensstemmelseserklæringens fulde tekst kan findes på følgende internetadresse:

<http://www.tokai-rika.co.jp/pc>

Frekvensbånd: 433.050 - 434.790 MHz
Maksimal radiofrekvenseffekt: 10mW (ERP)

Hiermit erkläre TOKAI RIKA CO., LTD., dass der Funkanlagentyp B3H2K2R der Richtlinie 2014/53/EU entspricht.

Der vollständige Text der EU-Konformitätserklärung ist unter der folgenden Internetadresse verfügbar:

<http://www.tokai-rika.co.jp/pc>

Frequenzband: 433.050 - 434.790 MHz
Abgestrahlte maximale Sendeleistung: 10mW (ERP)

Με την παρούσα ο/η TOKAI RIKA CO., LTD., δηλώνει ότι ο ραδιοεξοπλισμός B3H2K2R πληροί την οδηγία 2014/53/EE.

Το πλήρες κείμενο της δήλωσης συμμόρφωσης ΕΕ διατίθεται στην ακόλουθη ιστοσελίδα στο διαδίκτυο:

<http://www.tokai-rika.co.jp/pc>

Ζώνη συχνοτήτων: 433.050 - 434.790 MHz
Μέγιστη ισχύς ραδιοσυχνότητας: 10mW (ERP)

Il fabbricante, TOKAI RIKA CO., LTD., dichiara che il tipo di apparecchiatura radio B3H2K2R è conforme alla direttiva 2014/53/UE.

Il testo completo della dichiarazione di conformità UE è disponibile al seguente indirizzo Internet:

<http://www.tokai-rika.co.jp/pc>

Banda di frequenza: 433.050 - 434.790 MHz
Potenza massima radiofrequenza: 10mW (ERP)

Por la presente, TOKAI RIKA CO., LTD. declara que el tipo de equipo radioeléctrico B3H2K2R es conforme con la Directiva 2014/53/UE.

El texto completo de la declaración UE de conformidad está disponible en la dirección Internet siguiente:

<http://www.tokai-rika.co.jp/pc>

Banda de frecuencia: 433.050 - 434.790 MHz
Potencia máxima de radiofrecuencia: 10mW (ERP)

O(a) abaixo assinado(a) TOKAI RIKA CO., LTD. declara que o presente tipo de equipamento de rádio B3H2K2R está em conformidade com a Diretiva 2014/53/UE.

O texto integral da declaração de conformidade está disponível no seguinte endereço de Internet:

<http://www.tokai-rika.co.jp/pc>

Banda de frequência: 433.050 - 434.790 MHz
Potência máxima de radiofrequências: 10mW (ERP)

<p>B'dan, TOKAI RIKA CO., LTD., niddikjara li dan it-tip ta' tagħmir tar-radju B3H2K2R huwa konformi mad-Direttiva 2014/53/UE.</p> <p>It-test kollu tad-dikjarazzjoni ta' konformità tal-UE huwa disponibbli f'dan l-indirizz tal-Internet li ġej: http://www.tokai-rika.co.jp/pc</p> <p>Tiġnisviġ: 433.050 - 434.790 MHz Hámarks útvarpsbylgjutiðni: 10mW (ERP)</p>
<p>Käesolevaga deklareerib TOKAI RIKA CO., LTD., et käesolev raadioseadme tüüp B3H2K2R vastab direktiivi 2014/53/EL nõuetele.</p> <p>ELi vastavusdeklaratsiooni täielik tekst on kättesaadav järgmisel internetiaadressil: http://www.tokai-rika.co.jp/pc</p> <p>Sagedusriba: 433.050 - 434.790 MHz Maksimaalne saatevõimsus: 10mW (ERP)</p>
<p>TOKAI RIKA CO., LTD. igazolja, hogy a B3H2K2R típusú rádióberendezés megfelel a 2014/53/EU irányelvnek.</p> <p>Az EU-megfelelőségi nyilatkozat teljes szövege elérhető a következő internetes címen: http://www.tokai-rika.co.jp/pc</p> <p>Frekvenciasáv: 433.050 - 434.790 MHz Maximális jelerősség: 10mW (ERP)</p>
<p>TOKAI RIKA CO., LTD. týmto vyhlasuje, že rádiové zariadenie typu B3H2K2R je v súlade so smernicou 2014/53/EÚ.</p> <p>Úplné EÚ vyhlásenie o zhode je k dispozícii na tejto internetovej adrese: http://www.tokai-rika.co.jp/pc</p> <p>Frekvenčné pásmo: 433.050 - 434.790 MHz Maximálny rádiový výkon: 10mW (ERP)</p>

Tímto TOKAI RIKA CO., LTD. prohlašuje, že typ rádiového zařízení B3H2K2R je v souladu se směrnicí 2014/53/EU.

Úplné znění EU prohlášení o shodě je k dispozici na této internetové adrese:

<http://www.tokai-rika.co.jp/pc>

Kmitočtové pásmo: 433.050 - 434.790 MHz
Maximální radiofrekvenční výkon: 10mW (ERP)

TOKAI RIKA CO., LTD. potvrzuje, da je tip radijske opreme B3H2K2R skladen z Direktivo 2014/53/EU.

Celotno besedilo izjave EU o skladnosti je na voljo na naslednjem spletnem naslovu:

<http://www.tokai-rika.co.jp/pc>

Frekvenčni pas: 433.050 - 434.790 MHz
Največja moč radijske frekvence: 10mW (ERP)

Aš, TOKAI RIKA CO., LTD., patvirtinu, kad radijo įrenginių tipas B3H2K2R atitinka Direktyvą 2014/53/ES.

Visas ES atitikties deklaracijos tekstas prieinamas šiuo interneto adresu:

<http://www.tokai-rika.co.jp/pc>

Dažnių juosta: 433.050 - 434.790 MHz
Didžiausia radijo dažnių galia: 10mW (ERP)

Ar šo TOKAI RIKA CO., LTD. deklarė, ka radioiekārta B3H2K2R atbilst Direktīvai 2014/53/ES.

Pilns ES atbilstības deklarācijas teksts ir pieejams šādā interneta vietnē:

<http://www.tokai-rika.co.jp/pc>

Frekvenču josla: 433.050 - 434.790 MHz
Maksimālā radiofrekvenču jauda: 10mW (ERP)

<p>TOKAI RIKA CO., LTD. niniejszym oświadcza, że typ urządzenia radiowego B3H2K2R jest zgodny z dyrektywą 2014/53/UE.</p> <p>Pełny tekst deklaracji zgodności UE jest dostępny pod następującym adresem internetowym: http://www.tokai-rika.co.jp/pc</p> <p>Zakres częstotliwości: 433.050 - 434.790 MHz Maksymalna moc częstotliwości radiowej: 10mW (ERP)</p>
<p>TOKAI RIKA CO., LTD. lýsir því hér með yfir að fjarskiptatækið af gerð B3H2K2R er í samræmi við tilskipun 2014/53/EU.</p> <p>Öll ESB-samræmisýfirlýsingin er tiltæk á eftirfarandi vefslóð: http://www.tokai-rika.co.jp/pc</p> <p>Tíðnisvið: 433.050 - 434.790 MHz Hámarks útvarpsbylgjutíðni: 10mW (ERP)</p>
<p>TOKAI RIKA CO., LTD. erklærer herved at radioutstyrtypen B3H2K2R er i samsvar med direktivet 2014/53/EU.</p> <p>Hele teksten av EU-samsvarserklæringen kan leses på det følgende nettstedet: http://www.tokai-rika.co.jp/pc</p> <p>Frekvensbånd: 433.050 - 434.790 MHz Maksimal radiofrekvensseffekt: 10mW (ERP)</p>
<p>С настоящото TOKAI RIKA CO., LTD. декларира, че този тип радиосъоръжение B3H2K2R е в съответствие с Директива 2014/53/ЕС.</p> <p>Цялостният текст на ЕС декларацията за съответствие може да се намери на следния интернет адрес: http://www.tokai-rika.co.jp/pc</p> <p>Радиочестотна лента: 433.050 - 434.790 MHz Максимална радиочестотна мощност: 10mW (ERP)</p>

Prin prezenta, TOKAI RIKA CO., LTD. declară că tipul de echipamente radio B3H2K2R este în conformitate cu Directiva 2014/53/UE.

Textul integral al declarației UE de conformitate este disponibil la următoarea adresă internet:

<http://www.tokai-rika.co.jp/pc>

Banda de frecvență: 433.050 - 434.790 MHz

Puterea maximă de radiofrecvență: 10mW (ERP)

Ovime TOKAI RIKA CO., LTD. potvrđuje da je radio-oprema tipa B3H2K2R u skladu sa Direktivom 2014/53/EU.

Potpuni tekst EU deklaracije o usaglašenosti dostupan je na slijedećoj internet adresi:

<http://www.tokai-rika.co.jp/pc>

Frekvencijski opseg: 433.050 - 434.790 MHz

Maksimalna radio-frekvencijska snaga: 10mW (ERP)

Me anë të këtij dokumenti, TOKAI RIKA CO., LTD. deklaroi se tipi i radiopajisjes B3H2K2R është në përputhje me Direktivën 2014/53/EU.

Teksti i plotë i deklaratës së konformitetit të Bashkimit Evropian është i disponueshëm në adresën e mëposhtme të internetit:

<http://www.tokai-rika.co.jp/pc>

Brezi i frekuencës: 433.050 - 434.790 MHz

Fuqia maksimale e radiofrekuencës: 10mW (ERP)

TOKAI RIKA CO., LTD. ovime izjavljuje da je radijska oprema tipa B3H2K2R u skladu s Direktivom 2014/53/EU.

Cjeloviti tekst EU izjave o sukladnosti dostupan je na sljedećoj internetskoj adresi:

<http://www.tokai-rika.co.jp/pc>

Frekvencijski pojas: 433.050 - 434.790 MHz

Maksimalna RF snaga: 10mW (ERP)

Ovim TOKAI RIKA CO., LTD. potvrđuje da je radio-oprema tipa B3H2K2R u skladu sa Direktivom 2014/53/EU.

Potpuni tekst EU deklaracije o usaglašenosti dostupan je na sledećoj internet adresi:

<http://www.tokai-rika.co.jp/pc>

Frekventni opseg: 433.050 - 434.790 MHz

Maksimalna radio-frekventna snaga: 10mW (ERP)

TOKAI RIKA CO., LTD., işbu belgeyle telsiz cihazı türünün B3H2K2R 2014/53/EU nolu Direktif ile uyumlu olduğunu beyan etmektedir.

AB uygunluk beyanının tam metnine aşağıdaki internet adresinden ulaşabilirsiniz:

<http://www.tokai-rika.co.jp/pc>

Frekans bandı: 433.050 - 434.790 MHz

Maksimum radyo frekans gücü: 10mW (ERP)



Address: 3-260 Toyota, Oguchi-cho, Niwa-gun, Aichi 480-0195, Japan

: This mark is a safety/warning mark.

- Do not ingest battery.

Chemical Burn Hazard

- This product contains a coin / button cell battery.
- If the coin / button cell battery is swallowed, it can cause severe internal burns in just 2 hours and can lead to death.
- Keep new and used batteries away from children.
- If the battery compartment does not close securely, stop using the product and keep it away from children.
- If you think batteries might have been swallowed or placed inside any part of the body, seek immediate medical attention.

CAUTION

- Risk of explosion if the battery is replaced by an incorrect type.
- Replace battery with the same type.

CAUTION

- Risk of explosion or the leakage of flammable liquid or gas.
- Do not use in /store in /bring into environment of extremely high temperature or extremely low pressure due to the very high altitude.
- Do not attempt to burn, crush, or cut used battery.

 : Tämä on turva-/varoituserkki.

- Paristoa ei saa laittaa suuhun.

Kemiallisen palovamman vaara

- Laitteessa on kolikko-/nappiparisto.
- Elimistöön joutunut kolikko-/nappiparisto voi aiheuttaa vakavia sisäisiä palovammoja vain 2 tunnissa, jolloin seurauksena voi olla hengen menetys.
- Uudet ja käytetyt paristot on pidettävä poissa lasten ulottuvilta.
- Jos paristolokero ei sulkeudu kunnolla, laitteen käyttö on lopetettava, ja laite on pidettävä poissa lasten ulottuvilta.
- Jos on syytä epäillä, että paristo on nielaistu tai muuten päässyt elimistöön, ota välittömästi yhteyttä lääkäriin.

TÄRKEÄ HUOMAUTUS

- Käytetyn pariston vaihtaminen tyybiltään väärään voi aiheuttaa räjähdysvaaran.
- Vaihda paristo tyybiltään samanlaiseen.

TÄRKEÄ HUOMAUTUS

- Räjähdysvaara tai syttyvän nesteen tai kaasun vuotovaara.
- Ei saa käyttää/säilyttää/tuoda lämpötilaltaan tai merenpinnasta mitattuna erittäin korkeaan ympäristöön, jossa ilmanpaine on erittäin alhainen.
- Käytettyä paristoa ei saa polttaa, murskata tai halkaista.

<p>⚠ : Dit teken is een veiligheids-/waarschuwingsteken.</p> <ul style="list-style-type: none"> • Slik de batterij niet in. <p>Risico op chemische brandwonden</p> <ul style="list-style-type: none"> • Dit product bevat een munt-/knoopcelbatterij. • Als de munt-/knoopcelbatterij wordt ingeslikt, kan het al binnen 2 uur ernstige interne brandwonden veroorzaken en de dood tot gevolg hebben. • Houd nieuwe en gebruikte batterijen buiten bereik van kinderen. • Als het batterijcompartiment niet goed sluit, stop dan met het gebruik van het product en houd het buiten bereik van kinderen. • Als u denkt dat batterijen zijn ingeslikt of in enig deel van het lichaam zijn gestopt, roep dan onmiddellijk medische hulp in. <p>VOORZICHTIG</p> <ul style="list-style-type: none"> • Er bestaat een risico op ontploffing als de batterij wordt vervangen door een verkeerd type. • Vervang de batterij door een van hetzelfde type. <p>VOORZICHTIG</p> <ul style="list-style-type: none"> • Er bestaat een risico op ontploffing of lekkage van brandbare vloeistof of gas. <ul style="list-style-type: none"> • Niet gebruiken in/bewaren in/meenemen naar een omgeving met extreem hoge temperatuur of met extreem lage druk als gevolg van zeer grote hoogte. • Een gebruikte batterij niet verbranden, platdrukken, of doorsnijden.
<p>⚠ : Ce pictogramme est une marque de sécurité/avertissement.</p> <ul style="list-style-type: none"> • Ne pas ingérer la pile. <p>Risques de brûlure chimique</p> <ul style="list-style-type: none"> • Ce produit contient une pile bouton. • Si la pile bouton est avalée, elle peut causer de graves brûlures internes en seulement 2 heures et peut entraîner la mort. • Conservez les piles neuves et usagées hors de portée des enfants. • Si le compartiment de la pile ne ferme pas correctement, cessez d'utiliser le produit et conservez-le hors de portée des enfants. • Si vous pensez que des piles ont pu être avalées ou placées à l'intérieur d'une partie du corps, consultez immédiatement un médecin. <p>AVERTISSEMENT</p> <ul style="list-style-type: none"> • Risque d'explosion si la pile est remplacée par un type incorrect. • Remplacez la pile par une pile du même type. <p>AVERTISSEMENT</p> <ul style="list-style-type: none"> • Risque d'explosion ou de fuite de liquide ou de gaz inflammable. <ul style="list-style-type: none"> • Ne jamais utiliser, stocker, placer dans un environnement à la température extrêmement élevée ou à la pression extrêmement basse en raison d'une très haute altitude. • Ne jamais essayer de brûler, écraser ou couper des piles usagées.

: Det här märket är ett säkerhets-/varningsmärke.

- Förtär inte batteriet.

Risk för kemisk brännskada

- Den här produkten innehåller ett mynt-/knappbatteri.
- Om mynt-/knappbatteriet sväljs kan det orsaka allvarliga interna brännskador på bara två timmar, vilket kan leda till dödsfall.
- Håll nya och använda batterier borta från barn.
- Om batterifacket inte stängs ordentligt, sluta använda produkten och håll den undan från barn.
- Om du misstänker att batterier har svalts eller placerats inuti någon del av kroppen, sök omedelbart läkarvård.

VARNING

- Risk för explosion om batteriet byts ut mot ett av fel typ.
- Byt ut batteriet mot ett av samma typ.

VARNING

- Risk för explosion eller läckage av brandfarliga vätskor och gaser.

- Använd inte, förvara inte och ta inte in i miljö med extremt hög temperatur eller extremt lågt tryck p.g.a. hög höjd.

- Försök inte bränna, krossa eller skära använt batteri.

 : Dette mærke er et sikkerheds-/advarelsmærke.

- Batteriet må ikke indtages.

Fare for kemisk forbrænding

- Dette produkt indeholder et mønt-/knapcellebatteri.
- Hvis mønt-/knapcellebatteriet sluges, kan det medføre alvorlige indre forbrændinger i løbet af kun 2 timer og kan føre til dødsfald.
- Opbevar nye og brugte batterier utilgængeligt for børn.
- Hvis batterirummet ikke kan lukkes ordentligt, skal du indstille brugen af produktet og opbevare det utilgængeligt for børn.
- Hvis du har mistanke om, at der måske er blevet slugt batterier, eller batterier på anden måde er kommet ind i kroppen, skal du øjeblikkeligt søge lægehjælp.

FORSIGTIG



- Risiko for eksplosion, hvis batteriet udskiftes med en forkert type.
- Udskift batteriet med et batteri af samme type.



FORSIGTIG

- Risiko for eksplosion eller lækage af brændbar væske eller gas.

- Må ikke anvendes på/opbevares på/tages med til meget varme steder eller steder med meget lavt tryk som følge af ekstreme højder.

- Forsøg ikke at brænde, knuse eller adskille brugte batterier.

<p>: Dieses Symbol ist ein Sicherheits-/Warnsymbol.</p> <ul style="list-style-type: none"> ·Verschlucken Sie die Batterie nicht. <p>Verätzungsgefahr</p> <ul style="list-style-type: none"> ·Dieses Produkt enthält eine Knopfzellenbatterie. ·Falls die Knopfzellenbatterie verschluckt wird, kann dies innerhalb von nur 2 Stunden schwere innere Verätzungen verursachen und zum Tode führen. ·Halten Sie neue und gebrauchte Batterien von Kindern fern. ·Falls sich das Batteriefach nicht sicher schließen lässt, stellen Sie die Verwendung des Produkts ein und halten Sie es von Kindern fern. ·Falls Sie glauben, dass Batterien eventuell verschluckt oder in einen Teil des Körpers eingeführt worden sind, begeben Sie sich sofort in ärztliche Behandlung. <p>ACHTUNG</p> <ul style="list-style-type: none"> ·Es besteht Explosionsgefahr, falls die Batterie durch eine Batterie der falschen Art ersetzt wird. ·Ersetzen Sie Batterien nur durch die gleiche Art. <p>ACHTUNG</p> <ul style="list-style-type: none"> ·Es besteht Explosionsgefahr oder die Gefahr eines Austritts von brennbarer Flüssigkeit oder entzündlichem Gas. ·Das Produkt darf nicht in Umgebungen mit hohen Temperaturen oder extrem niedrigem Luftdruck aufgrund von extremen Höhenlagen verwendet / aufbewahrt / gebracht werden. ·Versuchen Sie nicht, gebrauchte Batterien zu verbrennen, zu zerstoßen oder zu schneiden. 	<p>: Το σήμα αυτό είναι ένα σήμα ασφαλείας/προειδοποίησης.</p> <ul style="list-style-type: none"> · Μην καταπίνετε την μπαταρία. <p>Κίνδυνος χημικού εγκαύματος</p> <ul style="list-style-type: none"> · Αυτό το προϊόν περιέχει μια μπαταρία σχήματος νομίσματος / κουμπιού. · Αν η μπαταρία σχήματος νομίσματος / κουμπιού καταποθεί, μπορεί να προκαλέσει σοβαρά εσωτερικά εγκαύματα σε μόλις 2 ώρες και μπορεί να επέλθει θάνατος. · Διατηρείτε τις καινούργιες και τις χρησιμοποιημένες μπαταρίες μακριά από παιδιά. · Εάν το διαμέρισμα της μπαταρίας δεν κλείνει καλά, σταματήστε τη χρήση του προϊόντος και κρατήστε το μακριά από παιδιά. · Αν νομίζετε ότι οι μπαταρίες ενδέχεται να έχουν καταποθεί ή τοποθετηθεί μέσα σε οποιοδήποτε μέρος του σώματος, ζητήστε αμέσως ιατρική φροντίδα. <p>ΠΡΟΣΟΧΗ</p> <ul style="list-style-type: none"> · Υπάρχει κίνδυνος έκρηξης εάν η μπαταρία αντικατασταθεί με μπαταρία εσφαλμένου τύπου. · Αντικαταστήστε την μπαταρία με μπαταρία του ίδιου τύπου. <p>ΠΡΟΣΟΧΗ</p> <ul style="list-style-type: none"> · Υπάρχει κίνδυνος έκρηξης ή διαρροής εύφλεκτων υγρών ή αερίων. · Μη χρησιμοποιείτε / αποθηκεύετε / μεταφέρετε το προϊόν σε περιβάλλον με εξαιρετικά υψηλή θερμοκρασία ή εξαιρετικά χαμηλή πίεση λόγω πολύ μεγάλου υψομέτρου. · Μην επιχειρήσετε να κάψετε, να συνθλίψετε ή να κόψετε μια χρησιμοποιημένη μπαταρία.
--	---

<p> : Questo è un simbolo di sicurezza/avvertenza.</p> <ul style="list-style-type: none"> • Non ingerire la batteria. <p>Pericolo di ustioni chimiche</p> <ul style="list-style-type: none"> • Questo prodotto contiene una batteria a bottone/moneta. • Se la batteria a bottone/moneta viene ingerita, può causare gravi ustioni interne in sole 2 ore e provocare la morte. • Tenere le batterie nuove e usate lontano dalla portata dei bambini. • Se il vano batteria non si chiude in modo saldo, interrompere l'utilizzo del prodotto e tenerlo lontano dalla portata dei bambini. • Se si ritiene che le batterie siano state ingerite o inserite in qualsiasi parte del corpo, consultare immediatamente un medico. <p>ATTENZIONE</p> <ul style="list-style-type: none"> • Rischio di esplosione in caso di sostituzione della batteria con una di tipo errato. • Sostituire la batteria con una dello stesso tipo. <p>ATTENZIONE</p> <ul style="list-style-type: none"> • Rischio di esplosione o di perdita di liquidi o gas infiammabili. • Non utilizzare / immagazzinare / portare in ambienti con temperatura estremamente alta o pressione estremamente alta a causa dell'elevata altitudine. • Non provare a bruciare, schiacciare o tagliare la batteria usata.
<p> : Este símbolo es un símbolo de seguridad/precaución.</p> <ul style="list-style-type: none"> • No ingerir la batería. <p>Peligro de quemadura química</p> <ul style="list-style-type: none"> • Este producto contiene una batería de pila de botón. • Si se ingiere la batería de pila de botón, esta puede causar graves quemaduras internas en solo 2 horas y puede provocar la muerte. • Mantenga las baterías nuevas y usadas alejadas de los niños. • Si el compartimento de la batería no se cierra correctamente, deje de usar el producto y manténgalo alejado de los niños. • Si cree que las baterías hayan podido ser ingeridas o introducidas en alguna parte del cuerpo, busque inmediatamente atención médica. <p>ATENCIÓN</p> <ul style="list-style-type: none"> • Riesgo de explosión si la batería es reemplazada por una del tipo incorrecto. • Reemplace la batería por una del mismo tipo. <p>ATENCIÓN</p> <ul style="list-style-type: none"> • Riesgo de explosión o escape de líquido o gas inflamable. • No usar / almacenar / introducir en un ambiente de temperatura extremadamente alta o de presión extremadamente baja a causa de la alta altitud. • No intente quemar, aplastar, o cortar la batería usada.

<p>⚠: Esta marca é uma marca de segurança/aviso.</p> <ul style="list-style-type: none"> • Não ingerir a pilha. <p>Perigo de Queimadura Química</p> <ul style="list-style-type: none"> • Este produto contém uma pilha de tipo moeda/botão. • Se a pilha de tipo moeda/botão for engolida, poderá causar queimaduras internas graves em apenas 2 horas e levar à morte. • Manter as pilhas novas e usadas longe de crianças. • Se o compartimento da pilha não se fechar completamente, cessar a utilização do produto e manter fora do alcance das crianças. • Caso seja possível que as pilhas tenham sido engolidas ou colocadas dentro de qualquer parte do corpo, procurar cuidados médicos imediatamente. <p>CUIDADO</p> <ul style="list-style-type: none"> • Risco de explosão se a pilha for substituída por uma de tipo incorreto. • Substituir a pilha por uma do mesmo tipo. <p>CUIDADO</p> <ul style="list-style-type: none"> • Risco de explosão ou fuga de líquidos ou gases inflamáveis. <ul style="list-style-type: none"> • Não utilizar/armazenar/colocar em ambiente de temperatura extremamente alta, ou pressão extremamente baixa devido a altitude muito alta. • Não tentar queimar, esmagar ou cortar a pilha usada.
<p>⚠: Din il-marka hija marka ta' sigurtá/twissija.</p> <ul style="list-style-type: none"> • Tiblax il-batterija. <p>Periklu ta' Ħruq Kimiku</p> <ul style="list-style-type: none"> • Dan il-prodott fih batterija munita / button cell. • Jekk tinbela' l-batterija munita / button cell, tista' tikkawża ħruq intern sever f'temp ta' sagħtejn biss u tista' twassal għall-mewt. • Żomm il-batteriji għodda u użati 'l bogħod mit-tfal. • Jekk il-kompartiment tal-batterija ma jagħlaqx sew, waqqaf l-użu tal-prodott u żommu 'l bogħod mit-tfal. • Jekk taħseb li l-batteriji setgħu nbelgħu jew tpoġġew għewwa xi parti tal-gisem, fittex attenzjoni medika immedjata. <p>ATTENZJONI</p> <ul style="list-style-type: none"> • Riskju ta' spluzjoni jekk il-batterija tiġi ssostitwita b'tip inkorrett. • Ibdel il-batterija bl-istess tip. <p>ATTENZJONI</p> <ul style="list-style-type: none"> • Riskju ta' spluzjoni jew trinxija ta' likwidu jew gass f'ammabbli. <ul style="list-style-type: none"> • Tuzahx / taħznux / iġġibux f'ambjent ta' temperatura estremament għolja jew pressjoni estremament baxxa minħabba l-altitudni għolja ħafna. • Tippruvax taħraq, tfarrak jew tqatta' l-batteriji użati.

⚠: See märk on ohutus-/hoiatusmärk.

•Ärge patareid alla neelake.

Keemilise põletuse oht

•See toode sisaldab mündi/nööbi tüüpi elemendiga patareid.

•Mündi/nööbi tüüpi elemendiga patareid allaneelamine võib põhjustada raskeid sisemisi põletusi juba 2 tunni jooksul ning võib lõppeda surmaga.

•Hoidke uued ja kasutatud patareid lastele kättesaamatus kohas.

•Kui patareipesa ei sulgu kindlalt, lõpetage toote kasutamine ja hoidke seda lastele kättesaamatus kohas.

•Kui te arvate, et patareid võivad olla alla neelatud või mistahes kehaossa sattunud, pöörduge viivitamatult arsti poole.

ETTEVAATUST

•Plahvatusoht vahetamisel vale tüüpi patareiga.

•Vahetage sama tüüpi patareiga.

ETTEVAATUST

•Plahvatuse või tuleohtliku vedeliku või gaasi lekke oht.

•Ärge kasutage, hoidke ega tooge keskkonda eriti kõrge temperatuuriga või eriti madala rõhuga väga suure kõrguse tõttu merepinnast.

•Ärge üritage põletada, purustada ega lõigata kasutatud patareid.

⚠ : Ez a jelzés biztonsági/figyelmeztető jelzés.

•Ne nyelje le az elemet.

Vegyí anyag okozta égésisérülés-veszély

•Ez a termék gombelemet tartalmaz.

•Amennyiben a gombelemet lenyeli, az mindössze 2 órán belül komoly belső égési sérüléseket okozhat és halálhoz vezethet.

•Az új és használt elemeket tartsa távol a gyermekektől.

•Amennyiben az elemtartó rekesz nem zárható biztonságosan, függessze fel a termék használatát és tartsa gyermekektől távol.

•Amennyiben úgy véli, hogy az elemet lenyelték vagy bármely testrészbe helyezték, haladéktalanul forduljon orvoshoz.

VIGYÁZAT

•Nem megfelelő típusú csereelem használata robbanásveszélyes.

•Az elemcseréhez azonos típusú elemet használjon.

VIGYÁZAT

•Rohbanásveszély vagy gyúlékony folyadékok vagy gázok szivárgása.

•Ne használja/ne tárolja/ne helyezze szélsőségesen magas hőmérsékletű környezetbe, és ne tegye ki a nagy magasságokban kialakuló rendkívül alacsony nyomásnak.

•A használt elemet ne kísérelje meg elégetni, összezúzni vagy szétvágni.

<p>⚠ : Toto je bezpečnostná/výstražná značka.</p> <ul style="list-style-type: none"> • Dbajte na to, aby nedošlo k prehltnutiu batérie. <p>Nebezpečenstvo poleptania chemikáliou</p> <ul style="list-style-type: none"> • Tento výrobok obsahuje mincovú/gombíkovú batériu. • Ak dôjde k prehltnutiu mincovej/gombíkovej batérie, už v priebehu 2 hodín môže spôsobiť vážne vnútorné poleptanie a viesť k usmrteniu. • Nové a použité batérie uchovávajte mimo dosahu detí. • Ak sa priestor pre batériu nezatvorí bezpečne, prestaňte používať výrobok a uchovávajte ho mimo dosahu detí. • Ak si myslíte, že mohlo dôjsť k prehltnutiu batérií alebo ich umiestneniu do ktorejkoľvek časti tela, okamžite vyhľadajte lekársku pomoc. <p>UPOZORNENIE</p> <ul style="list-style-type: none"> • Hrozí nebezpečenstvo výbuchu, ak sa batéria vymení za nesprávny typ. • Vymeňte batériu za rovnaký typ. <p>UPOZORNENIE</p> <ul style="list-style-type: none"> • Nebezpečenstvo výbuchu alebo úniku horľavej kvapaliny alebo horľavého plynu. <ul style="list-style-type: none"> • Nepoužívajte/neskladujte v prostredí/nepřinášajte do prostredia s mimoriadne vysokou teplotou, alebo mimoriadne nízkym tlakom v dôsledku veľmi vysokej nadmorskej výšky. • Nepokúšajte sa spáliť, rozdrviť ani rozrezať použitú batériu.
<p>⚠ : Tento symbol je bezpečnostným/výstražným symbolom.</p> <ul style="list-style-type: none"> • Baterii nepolykejte. <p>Nebezpečí chemických popálenin</p> <ul style="list-style-type: none"> • Tento výrobok obsahuje mincovou/knoflíkovou batériu. • Pokiaľ dojde ke spolknutiu mincové/knoflíkové batérie, môže za pouhé 2 hodiny spôsobiť závažné vnútorné popáleniny a v jejich dôsledku prípadne i smrť. • Použité a nové batérie udržiavajte mimo dosah detí. • Pokiaľ nelze priestor pro batériu pevně uzavřít, přestaňte výrobek používat a udržiavte jej mimo dosah detí. • Pokiaľ si myslíte, že mohlo dojsť ke spolknutiu batérie alebo jejímú vsunutiu dovnitř ktorejkoľvek časti tela, okamžite vyhľadajte lekárska pomoc. <p>UPOZORNĚNÍ</p> <ul style="list-style-type: none"> • Nebezpečí výbuchu v případě výměny baterie za nesprávný druh baterie. • Proto baterii vždy vyměňte za jinou stejného typu. <p>UPOZORNĚNÍ</p> <ul style="list-style-type: none"> • Nebezpečí výbuchu nebo úniku hořlavé kapaliny či plynu. <ul style="list-style-type: none"> • Nepoužívejte/neskladujte/nepřinášejte je do prostředí s nesmírně vysokou teplotou nebo nesmírně nízkým tlakem zapříčiněným vysokou nadmořskou výškou. • Nesnažte se baterii spálit, rozdrtit či rozříznout.

⚠ : Ta oznaka je varnostna/opozorilna oznaka.

- Ne zaužijte baterije.

Nevarnost kemijske opeklina

- Ta izdelek vsebuje gumbasto baterijo.
- Če se gumbasto baterijo zaužije, lahko to povzroči hude notranje opeklina v le 2 urah in lahko vodi v smrt.
- Nove in rabljene baterije hranite izven dosega otrok.
- Če se predalček za baterijo ne zapira pravilno, prenehajte z uporabo izdelka in ga hranite izven dosega otrok.
- Če sumite, da je morda nekdo zaužil baterijo ali jo dal v kateri koli del telesa, takoj poiščite zdravniško pomoč.

POZOR

- Nevarnost eksplozije, če baterijo zamenjate z baterijo napačne vrste.
- Zamenjajte baterijo z istim tipom.

POZOR

- Tveganje za eksplozijo ali puščanje vnetljivih tekočin ali plinov.
- Ne uporabljajte/shranjujte/prinašajte v okolje izredno visoke temperature ali izredno nizkega tlaka zaradi zelo visoke nadmorske višine.
- Ne poskušajte zažigati, uničiti, ali rezati rabljene baterije.

⚠: Šis ženklas yra saugos/jspėjamas ženklas.

- Neprarykite baterijos.

Cheminių nudegimų pavojus

- Šiame gaminyje yra monetos/sagos formos baterija.
- Prarijęs monetos/sagos formos bateriją, asmuo per 2 valandas gali patirti sunkius vidinius nudegimus ir netgi mirti.
- Naujas ir panaudotas baterijas laikykite vaikams nepasiekiamoje vietoje.
- Jei baterijų skyrelis nepavyksta tvirtai uždaryti, nebenaudokite gaminio ir laikykite jį vaikams nepasiekiamoje vietoje.
- Jei manote, kad baterijos buvo prarytos arba pateko į kūną, nedelsdami kreipkitės į gydytoją.

PERSPĖJIMAS

- Bateriją pakeitus netinkamo tipo baterija, kyla sprogdimo pavojus.
- Pakeiskite seną bateriją tik to paties tipo nauja baterija.

PERSPĖJIMAS

- Sprogdimo arba degių skysčių ar dujų nuotėkio pavojus.
- Negalima naudoti/laikyti/turėti labai aukštos temperatūros arba labai dideliame aukštyje esančioje itin žemo slėgio aplinkoje.
- Naudotos baterijos nebandykite deginti, ardyti ar perpjauti.

<p>⚠ : Šī zīme ir drošības/brīdinājuma zīme.</p> <ul style="list-style-type: none"> • Nenorijiet bateriju. <p>Kīmisku apdegumu briesmas</p> <ul style="list-style-type: none"> • Šis izstrādājums satur tabletes tipa bateriju. • Ja ir norīta tabletes tipa baterija, tā 2 stundu laikā var radīt smagus apdegumus un izraisīt nāvi. • Jaunas un lietotas baterijas uzglabājiet bērniem nepieejamā vietā. • Ja bateriju nodalījumu nevar droši aizvērt, pārtrauciet lietot izstrādājumu un novietojiet to bērniem nepieejamā vietā. • Ja jūsuprāt baterijas ir norītas vai ievietotas kādā ķermeņa daļā, nekavējoties vērsieties pēc medicīniskās palīdzības. <p>UZMANĪBU!</p> <ul style="list-style-type: none"> • Eksplozijas risks, ja baterija tiek nomainīta ar nepareiza tipa bateriju. • Bateriju nomainiet pret tāda paša tipa bateriju. <p>UZMANĪBU!</p> <ul style="list-style-type: none"> • Eksplozijas vai uzliesmojoša šķidruma vai gāzes noplūdes risks. <ul style="list-style-type: none"> • Nelietojiet, neuzglabājiet un neievietojiet vidē ar ļoti augstu temperatūru, kā arī vidē, kur ļoti lielā augstuma virs jūras līmeņa dēļ ir ļoti zems spiediens. • Nemēģiniet sadedzināt, sagraut vai sagriezt nolietoto bateriju.
<p>⚠ : ten symbol oznacza niebezpieczeństwo/ostreżenie.</p> <ul style="list-style-type: none"> • Nie połykać baterii. <p>Ryzyko oparzenia chemicznego</p> <ul style="list-style-type: none"> • Ten produkt zawiera baterię guzikową. • Połknięta bateria guzikowa może spowodować poważne oparzenia wewnętrzne w czasie jedynie 2 godzin i prowadzić do śmierci. • Przechowywać nowe i zużyte baterie z dala od dzieci. • Jeśli solidne zamknięcie komory baterii jest niemożliwe, zaprzestać użytkowania produktu i przechowywać go w miejscu niedostępnym dla dzieci. • W przypadku podejrzenia, że mogło dojść do połknięcia baterii lub ich umieszczenia w dowolnym otworze ciała, niezwłocznie uzyskać pomoc lekarską. <p>PRZESTROGA</p> <ul style="list-style-type: none"> • Istnieje ryzyko wybuchu, jeśli bateria zostanie zastąpiona baterią niewłaściwego typu. • Wymieniać baterię na baterię tego samego typu. <p>PRZESTROGA</p> <ul style="list-style-type: none"> • Ryzyko wybuchu lub wycieku łatwopalnego płynu lub gazu. <ul style="list-style-type: none"> • Nie używać i nie przechowywać w otoczeniu o skrajnie wysokiej temperaturze lub skrajnie niskim ciśnieniu wynikającym z bardzo dużej wysokości ani nie wносить do takiego otoczenia. • Nie podejmować prób spalania, zgniecenia lub przecięcia zużytej baterii.

 : Този знак е знак за безопасност/предупреждение.

- Не поглъщайте батерията.

Опасност от химическо изгаряне

- Този продукт съдържа плоска/бутонна батерия.
- Ако плоската/бутонна батерия бъде погълната, тя може да причини тежки вътрешни изгаряния само за 2 часа и може да доведе до смърт.
- Пазете новите и използваните батерии далеч от деца.
- Ако отделението за батериите не се затваря добре, спрете да използвате продукта и го дръжте далеч от деца.
- Ако смятате, че батериите може да са били погълнати или поставени в някоя част на тялото, незабавно потърсете медицинска помощ.

ВНИМАНИЕ

- Опасност от експлозия, ако батерията бъде сменена с неправилен тип.
- Сменете батерията със същия вид.

ВНИМАНИЕ

- Опасност от експлозия или изтичане на запалими течности или газове.
- Не използвайте/съхранявайте/носете в среда с изключително висока температура или изключително ниско налягане, причинено от голямата височина.
- Не се опитвайте да изгаряте, смачквате или режете използваната батерия.

 : Acest marcaj este un marcaj de securitate/avertizare.

- Nu ingerați bateria.

Pericol de arsuri chimice

- Acest produs conține o baterie tip pastilă.
- Dacă bateria tip pastilă este înghițită, aceasta poate cauza arsuri interne grave în numai 2 ore și poate duce la deces.
- Nu lăsați bateriile noi și bateriile uzate la îndemâna copiilor.
- În cazul în care compartimentul bateriei nu se închide bine, încetați utilizarea produsului și nu îl lăsați la îndemâna copiilor.
- Dacă bănuți că este posibil ca bateriile să fi fost înghițite sau introduse în orice parte a corpului, consultați imediat medicul.

ATENȚIE

- Risc de explozie dacă bateria este înlocuită cu un tip incorect.
- Înlocuiți bateria cu una de același tip.

ATENȚIE

- Risc de explozie sau de scurgeri de lichide sau gaze inflamabile.
- Nu utilizați/depozitați într-un mediu cu temperatură extrem de înaltă sau cu presiune extrem de joasă din cauza altitudinii foarte mari.
- Nu încercați să ardeți, să spargeți sau să tăiați bateriile uzate.

<p>⚠ : Ova oznaka je oznaka sigurnosti/upozorenja.</p> <ul style="list-style-type: none"> •Nemojte gutati bateriju. <p>Opasnost od kemijskih opekline</p> <ul style="list-style-type: none"> •Ovaj proizvod sadrži novčić/gumb bateriju. •Ako se novčić/gumb baterija proguta, može uzrokovati ozbiljne unutarnje opekline u samo 2 sata i može dovesti do smrti. •Držite nove i rabljene baterije izvan dohvata djece. •Ako se pretinac za baterije ne zatvara sigurno, prestanite koristiti proizvod i držite ga dalje od djece. •Ako smatrate da su baterije možda progutane ili smještene unutar bilo kojeg dijela tijela, zatražite hitnu medicinsku pomoć. <p>OPREZ</p> <ul style="list-style-type: none"> •Ako je baterija zamijenjena pogrešnim tipom, postoji rizik od eksplozije. •Zamijenite bateriju s baterijama iste vrste. <p>OPREZ</p> <ul style="list-style-type: none"> •Rizik od eksplozije ili istjecanja zapaljive tekućine ili plina. <ul style="list-style-type: none"> •Nemojte koristiti u /pohranjivati u /unijeti u prostoru izuzetno visoke temperature ili izuzetno niskog tlaka zbog visoke nadmorske visine. •Ne pokušavajte spaliti, lomiti ili rezati istrošenu bateriju. 	<p>⚠ : Þetta tákn er öryggis-/aðvörunartákn.</p> <ul style="list-style-type: none"> •Gleypið ekki rafhlöðuna. <p>Hætta á efnabruna</p> <ul style="list-style-type: none"> •Þessi vara inniheldur flata rafhlöðu. •Ef rafhlöðan er gleypst getur hún valdið alvarlegum innvortis brunna á innan við 2 klukkustundum sem getur leitt til dauða. •Geymið nýjar og notaðar rafhlöður þar sem börn ná ekki til. •Ef rafhlöðuhólflið lokast ekki örugglega skal hætta notkun vörunnar og geyma hana þar sem börn ná ekki til. •Ef þú telur að rafhlöður hafi verið gleypst eða settar inn í eitthvert líkamsop, skaltu hafa samband við lækni tafarlaust. <p>VARÚÐ</p> <ul style="list-style-type: none"> •Hætta á sprengingu ef rafhlöðunni er skipt út fyrir ranga tegund. •Skiptið rafhlöðunni ávallt út fyrir sömu tegund. <p>VARÚÐ</p> <ul style="list-style-type: none"> •Hætta á sprengingu eða leka á eldfimum vökva eða lofttegundum. <ul style="list-style-type: none"> •Má ekki nota/geyma/setja í umhverfi þar sem er afar hár hiti, eða afar lágur þrýstingur vegna mikillar hæðar. •Ekki reyna að brenna, kremja eða skera notaða rafhlöðu.
--	---

⚠ : Dette merket er et sikkerhets-/advarselsmerke.

- Ikke svelg batteriet.

Kjemisk brannfare

- Dette produktet inneholder et mynt-/knappcellebatteri.
- Dersom mynt-/knappcellebatteriet svelges, kan det frembringe alvorlige indre forbrenninger i løpet av kun to timer, og kan være dødelig.
- Hold nye og brukte batterier borte fra barn.
- Lukkes ikke batterirommet sikkert må du stanse å bruke produktet og holde det utenfor barns rekkevidde.
- Oppsøk medisinsk hjelp umiddelbart hvis du tror at batterier kan være svelget eller plassert inne i kroppen.

FORSIKTIG

- Eksplisjonsfare hvis batteriet erstattes med feil type.
- Bytt batteri med samme type.

FORSIKTIG

- Fare for eksplosjon eller lekkasje av brannfarlig væske eller gass.

- Ikke bruk i/oppbevar i/ta med inn i miljø med ekstremt høy temperatur eller ekstremt lavt trykk på grunn av den svært store høyden.

- Ikke forsøk å brenne, knuse eller skjære opp et brukt batteri.

⚠ : Ova oznaka je sigurnosna/upozoravajuća oznaka.

- Nemojte gutati bateriju.

Opasnost od hemijskih opekotina

- Ovaj proizvod sadrži bateriju veličine kovanice/dugmeta.
- Ako se baterija veličine kovanice/dugmeta proguta, može izazvati ozbiljne unutrašnje opekotine za samo 2 sata i može dovesti do smrti.
- Čuvajte nove i korišćene baterije dalje od djece.
- Ako se prostor za baterije ne zatvori dobro, prestanite sa korišćenjem proizvoda i držite ga dalje od djece.
- Ako mislite da su baterije možda progutane ili stavljene u unutrašnjost bilo kog dijela tijela, potražite hitnu medicinsku pomoć.

OPREZ

- Opasnost od eksplozije ako se baterija zamijeni s baterijom pogrešnog tipa.
- Zamijenite bateriju sa baterijom istog tipa.

OPREZ

- Opasnost od eksplozije ili curenja zapaljive tečnosti ili gasa.

- Nemojte koristiti /skladištiti /unositi u okruženje izuzetno visoke temperature ili izuzetno niskog pritiska usljed veoma velike visine.

- Ne pokušavajte da spalite, lomite ili isječete iskorišćenu bateriju.

<p>⚠ : Kjo është shenjë sigurie/paralajmërimi.</p> <ul style="list-style-type: none"> • Mos e gëlltisni baterinë. <p>Rrezik djegieje kimike</p> <ul style="list-style-type: none"> • Ky produkt përmban një bateri të hollë në formë monedhe/kopse. • Nëse bateria e hollë në formë monedhe/kopse gëlltitet, ajo mund të shkaktojë djegie të rënda të brendshme brenda vetëm 2 orëve dhe mund të sjellë vdekjen. • Mbajini bateritë e reja dhe të përdorura larg nga fëmijët. • Nëse foleja e baterisë nuk mbyllet mirë, ndaloni përdorimin e produktit dhe mbajeni larg nga fëmijët. • Nëse mendoni se bateritë mund të jenë gëlltitur ose futur brenda ndonjë pjese trupi, kërkoni menjëherë vëmendjen e mjekut. <p>KUJDES</p> <ul style="list-style-type: none"> • Rrezik shpërthimi nëse bateria zëvendësohet me një lloj të pasaktë. • Zëvendësojeni baterinë me të njëjtin lloj. <p>KUJDES</p> <ul style="list-style-type: none"> • Rrezik shpërthimi nga rrjedhja e lëngut apo gazit të ndezshëm. <p>• Mos e përdorni / ruani / sillni në mjedise me temperaturë jashtëzakonisht të lartë ose presion jashtëzakonisht të ulët në lartësi shumë të mëdha.</p> <p>• Mos u përpiqni të digjini, shtypni ose prisni baterinë e përdorur.</p>
<p>⚠ : Ova oznaka je oznaka za bezbednost/upozorenje.</p> <ul style="list-style-type: none"> • Nemojte gutati bateriju. <p>Opasnost od hemijskih opekotina</p> <ul style="list-style-type: none"> • Ovaj proizvod sadrži bateriju u obliku novčića/dugmeta. • Ako se baterija u obliku novčića/gumba proguta, može da izazove ozbiljne interne opekotine za samo 2 sata i može da dovede do smrti. • Nove i korišćene baterije čuvajte van domašaja dece. • Ako se odeljak za bateriju ne zatvori dobro, prestanite da koristite proizvod i čuvajte ga van domašaja dece. • Ako mislite da su baterije možda progutane ili stavljene unutar bilo kog dela tela, odmah zatražite medicinsku pomoć. <p>OPREZ</p> <ul style="list-style-type: none"> • Rizik od eksplozije ako je baterija zamenjena nepravilnim tipom. • Zamenite bateriju sa istim tipom. <p>OPREZ</p> <ul style="list-style-type: none"> • Rizik od eksplozije ili curenja zapaljive tečnosti ili gasa. <p>• Ne koristite/ne čuvajte/ne donosite u sredinu izuzetno visoke temperature ili izuzetno niskog pritiska usled vrlo visoke visine.</p> <p>• Ne pokušavajte da zapalite, smrvite ili isečete korišćenu bateriju.</p>

⚠ : Bu işaret bir güvenlik/uyarı işaretidir.

•Pili yutmayın.

Kimyasal Yanma Tehlikesi

•Bu üründe bir düğme pil bulunmaktadır.

•Düğme pil yutulursa, sadece 2 saat içinde ağır iç yanıklara neden olabilir ve ölüme yol açabilir.

•Yeni ve kullanılmış pilleri çocuklardan uzak tutun.

•Pil yuvası emniyetli bir şekilde kapanmıyorsa, ürünü kullanmayı bırakın ve çocuklardan uzak tutun.

•Pillerin yutulduğunu veya vücudun herhangi bir parçasının içine yerleştirildiğini düşünüyorsanız, derhal tıbbi yardım alın.

DİKKAT

•Pil yanlış tür bir pille değiştirilirse patlama riski vardır.

•Pili aynı tür pillerle değiştirin.

DİKKAT

•Patlama ya da yanıcı sıvı veya gaz sızıntısı riski vardır.

•Aşırı derecede yüksek sıcaklıktaki veya çok yüksek rakımdan dolayı aşırı derecede düşük basınçta sahip ortamlarda kullanmayın /saklamayın veya bu ortamlara götürmeyin.

•Kullanılmış pili yakmaya, ezmeye veya kesmeye çalışmayın.

► For vehicles sold in Ukraine

Справжнім TOKAI RIKА CO., LTD. заявляє, що тип радіообладнання В3Н2К2R відповідає Технічному регламенту радіообладнання;

КАБІНЕТ МІНІСТРІВ УКРАЇНИ ПОСТАНОВА №.355

Повний текст декларації про відповідність доступний на веб-сайті за такою адресою:

<http://www.tokai-rika.co.jp/pc>

Діапазон частот : 433.050 - 434.790 MHz

Максимальна потужність радіочастотного випромінювання : 10 mW(ERP)



Адреса: 3-260 Toyota, Oguchi-cho, Niwa-gun, Aichi 480-0195, Japan



Ця позначка являє собою позначку про необхідність дотримання правил безпеки/застереження.

· Не допускайте проковтування батарейки.

Небезпека хімічного опіку

- Цей виріб містить батарейку монетного / таблеткового типу.
- Проковтування батарейки монетного / таблеткового типу може спричинити тяжкі внутрішні опіки всього лише за 2 години і може призвести до смерті.
- Зберігайте нові та використані батарейки подалі від дітей.
- Якщо кришка батарейного відсіку надійно не закривається, припиніть користуватися виробом і зберігайте його подалі від дітей.
- Якщо існує ймовірність проковтування батарейки або її розміщення всередині будь-якої частини тіла, негайно зверніться за медичною допомогою.

ОБЕРЕЖНО

- Ризик вибуху в разі заміни на батарейку неналежного типу.
- Замініть батарейку на батарейку такого ж самого типу.

ОБЕРЕЖНО

- Ризик вибуху або витoku горючої рідини або газу.
- Не використовуйте /не зберігайте /не розміщуйте в умовах надзвичайно високої температури або надзвичайно низького тиску через дуже велику висоту над рівнем моря.
- Не намагайтеся спалити, розбити або розрізати використану батарейку.

- ▶ For vehicles sold in Serbia



■ Smart ECU/antenna

Hereby, TOYOTA MOTOR CORPORATION declares that the radio equipment type TMLF19T-1 is in compliance with Directive 2014/53/EU.

The full text of the EU declaration of conformity is available at the following internet address:

<http://www.tokai-rika.co.jp/pc>

Frequency band: 119 - 135 kHz

Maximum radio-frequency power: 55dB μ A/m @10m

TOYOTA MOTOR CORPORATION vakuuttaa, että radiolaitetyyppi TMLF19T-1 on direktiivin 2014/53/EU mukainen.

EU-vaatimustenmukaisuusvakuutuksen täysimittainen teksti on saatavilla seuraavassa internetosoitteessa:

<http://www.tokai-rika.co.jp/pc>

Radiotaajuus: 119 - 135 kHz

suurin mahdollinen lähetysteho: 55dB μ A/m @10m

Hierbij verklaar ik, TOYOTA MOTOR CORPORATION, dat het type radioapparatuur TMLF19T-1 conform is met Richtlijn 2014/53/EU.

De volledige tekst van de EU-conformiteitsverklaring kan worden geraadpleegd op het volgende internetadres:

<http://www.tokai-rika.co.jp/pc>

Frequentieband: 119 - 135 kHz

Maximaal radiofrequentievermogen: 55dB μ A/m @10m

Le soussigné, TOYOTA MOTOR CORPORATION, déclare que l'équipement radioélectrique du type TMLF19T-1 est conforme à la directive 2014/53/UE.

Le texte complet de la déclaration UE de conformité est disponible à l'adresse internet suivante:

<http://www.tokai-rika.co.jp/pc>

Bande de fréquences: 119 - 135 kHz

Puissance de radiofréquence maximale: 55dB μ A/m @10m

Härmed försäkrar TOYOTA MOTOR CORPORATION att denna typ av radioutrustning TMLF19T-1 överensstämmer med direktiv 2014/53/EU.

Den fullständiga texten till EU-försäkran om överensstämmelse finns på följande webbadress:

<http://www.tokai-rika.co.jp/pc>

Frekvensband: 119 - 135 kHz

Maximal radiofrekvenseffekt: 55dB μ A/m @10m

Hermed erklærer TOYOTA MOTOR CORPORATION, at radioudstyrstypen TMLF19T-1 er i overensstemmelse med direktiv 2014/53/EU.

EU-overensstemmelseserklæringens fulde tekst kan findes på følgende internetadresse:

<http://www.tokai-rika.co.jp/pc>

Frekvensbånd: 119 - 135 kHz

Maksimal radiofrekvenseffekt: 55dBμA/m @10m

Hiermit erklärt TOYOTA MOTOR CORPORATION, dass der Funkanlagentyp TMLF19T-1 der Richtlinie 2014/53/EU entspricht.

Der vollständige Text der EU-Konformitätserklärung ist unter der folgenden Internetadresse verfügbar:

<http://www.tokai-rika.co.jp/pc>

Frequenzband: 119 - 135 kHz

Abgestrahlte maximale Sendeleistung: 55dBμA/m @10m

Με την παρούσα ο/η TOYOTA MOTOR CORPORATION, δηλώνει ότι ο ραδιοεξοπλισμός TMLF19T-1 πληροί την οδηγία 2014/53/ΕΕ.

Το πλήρες κείμενο της δήλωσης συμμόρφωσης ΕΕ διατίθεται στην ακόλουθη ιστοσελίδα στο διαδίκτυο:

<http://www.tokai-rika.co.jp/pc>

Ζώνη συχνοτήτων: 119 - 135 kHz

Μέγιστη ισχύς ραδιοσυχνότητας: 55dBμA/m @10m

Il fabbricante, TOYOTA MOTOR CORPORATION, dichiara che il tipo di apparecchiatura radio TMLF19T-1 è conforme alla direttiva 2014/53/UE.

Il testo completo della dichiarazione di conformità UE è disponibile al seguente indirizzo Internet:

<http://www.tokai-rika.co.jp/pc>

Banda di frequenza: 119 - 135 kHz

Potenza massima radiofrequenza: 55dB μ A/m @10m

Por la presente, TOYOTA MOTOR CORPORATION declara que el tipo de equipo radioeléctrico TMLF19T-1 es conforme con la Directiva 2014/53/UE.

El texto completo de la declaración UE de conformidad está disponible en la dirección Internet siguiente:

<http://www.tokai-rika.co.jp/pc>

Banda de frecuencia: 119 - 135 kHz

Potencia máxima de radiofrecuencia: 55dB μ A/m @10m

O(a) abaixo assinado(a) TOYOTA MOTOR CORPORATION declara que o presente tipo de equipamento de rádio TMLF19T-1 está em conformidade com a Diretiva 2014/53/UE.

O texto integral da declaração de conformidade está disponível no seguinte endereço de Internet:

<http://www.tokai-rika.co.jp/pc>

Banda de frequência: 119 - 135 kHz

Potência máxima de radiofrequências: 55dB μ A/m @10m

B'dan, TOYOTA MOTOR CORPORATION, niddikjara li dan it-tip ta' tagħmir tar-radju TMLF19T-1 huwa konformi mad-Direttiva 2014/53/UE.

It-test kollu tad-dikjarazzjoni ta' konformità tal-UE huwa disponibbli f'dan l-indirizz tal-Internet li ġej:

<http://www.tokai-rika.co.jp/pc>

Tíðnisvið: 119 - 135 kHz

Hámarks útvarpsbylgjutiðni: 55dB μ A/m @10m

Käesolevaga deklareerib TOYOTA MOTOR CORPORATION, et käesolev raadioseadme tüüp TMLF19T-1 vastab direktiivi 2014/53/EL nõuetele.

ELi vastavusdeklaratsiooni täielik tekst on kättesaadav järgmisel internetiaadressil:

<http://www.tokai-rika.co.jp/pc>

Sagedusriba: 119 - 135 kHz

Maksimaalne saatevõimsus: 55dB μ A/m @10m

TOYOTA MOTOR CORPORATION igazolja, hogy a TMLF19T-1 típusú rádióberendezés megfelel a 2014/53/EU irányelvnek.

Az EU-megfelelőségi nyilatkozat teljes szövege elérhető a következő internetes címen:

<http://www.tokai-rika.co.jp/pc>

Frekvenciasáv: 119 - 135 kHz

Maximális jelerősség: 55dB μ A/m @10m

TOYOTA MOTOR CORPORATION týmto vyhlasuje, že rádiové zariadenie typu TMLF19T-1 je v súlade so smernicou 2014/53/EÚ.

Úplné EÚ vyhlásenie o zhode je k dispozícii na tejto internetovej adrese:

<http://www.tokai-rika.co.jp/pc>

Frekvenčné pásmo: 119 - 135 kHz

Maximálny rádiový výkon: 55dB μ A/m @10m

Týmto TOYOTA MOTOR CORPORATION prohlašuje, že typ rádiového zariadenia TMLF19T-1 je v súlade so smernicou 2014/53/EÚ.

Úplné znění EU prohlášení o shodě je k dispozici na této internetové adrese:

<http://www.tokai-rika.co.jp/pc>

Kmitočtové pásmo: 119 - 135 kHz

Maximální radiofrekvenční výkon: 55dB μ A/m @10m

TOYOTA MOTOR CORPORATION potvrdzuje, że typ radijskiej opremy TMLF19T-1 składa się z Dyrektywy 2014/53/EU.

Celotno besedilo izjave EU o skladnosti je na voljo na naslednjem spletnem naslovu:

<http://www.tokai-rika.co.jp/pc>

Frekvenčni pas: 119 - 135 kHz

Največja moč radijske frekvence: 55dB μ A/m @10m

Aš, TOYOTA MOTOR CORPORATION, patvirtinu, kad radijo įrenginių tipas TMLF19T-1 atitinka Direktyvą 2014/53/ES.

Visas ES atitikties deklaracijos tekstas prieinamas šiuo interneto adresu:

<http://www.tokai-rika.co.jp/pc>

Dažnių juosta: 119 - 135 kHz

Didžiausia radijo dažnių galia: 55dB μ A/m @10m

Ar šo TOYOTA MOTOR CORPORATION deklarē, ka radioiekārta TMLF19T-1 atbilst Direktīvai 2014/53/ES.

Pilns ES atbilstības deklarācijas teksts ir pieejams šādā interneta vietnē:

<http://www.tokai-rika.co.jp/pc>

Frekvenču josla: 119 - 135 kHz

Maksimālā radiofrekvenču jauda: 55dB μ A/m @10m

TOYOTA MOTOR CORPORATION niniešzīm ošwadcza, że typ urządzenia radiowego TMLF19T-1 jest zgodny z dyrektywą 2014/53/UE.

Pełny tekst deklaracji zgodności UE jest dostępny pod następującym adresem internetowym:

<http://www.tokai-rika.co.jp/pc>

Zakres częstotliwości: 119 - 135 kHz

Maksymalna moc częstotliwości radiowej: 55dB μ A/m @10m

TOYOTA MOTOR CORPORATION lýsir því hér með yfir að fjarskiptatækið af gerð TMLF19T-1 er í samræmi við tilskipun 2014/53/EU.

Öll ESB-samræmisýfirlýsingin er tiltæk á eftirfarandi vefslóð:

<http://www.tokai-rika.co.jp/pc>

Tíðnisvið: 119 - 135 kHz

Hámarks útværpsbylgjutíðni: 55dB μ A/m @10m

TOYOTA MOTOR CORPORATION erklærer herved at radioutstyrtypen TMLF19T-1 er i samsvar med direktivet 2014/53/EU.

Hele teksten av EU-samsvarserklæringen kan leses på det følgende nettstedet:

<http://www.tokai-rika.co.jp/pc>

Frekvensbånd: 119 - 135 kHz

Maksimal radiofrekvenseffekt: 55dB μ A/m @10m

С настоящото TOYOTA MOTOR CORPORATION декларира, че този тип радиосъоръжение TMLF19T-1 е в съответствие с Директива 2014/53/ЕС.

Цялостният текст на ЕС декларацията за съответствие може да се намери на следния интернет адрес:

<http://www.tokai-rika.co.jp/pc>

Радиочестотна лента: 119 - 135 kHz

Максимална радиочестотна мощност: 55dB μ A/m @10m

Prin prezenta, TOYOTA MOTOR CORPORATION declară că tipul de echipamente radio TMLF19T-1 este în conformitate cu Directiva 2014/53/UE.

Textul integral al declarației UE de conformitate este disponibil la următoarea adresă internet:

<http://www.tokai-rika.co.jp/pc>

Banda de frecvență: 119 - 135 kHz

Puterea maximă de radiofrecvență: 55dB μ A/m @10m

Ovime TOYOTA MOTOR CORPORATION potvrđuje da je radio-oprema tipa TMLF19T-1 u skladu sa Direktivom 2014/53/EU.

Potpuni tekst EU deklaracije o usaglašenosti dostupan je na sljedećoj internet adresi:

<http://www.tokai-rika.co.jp/pc>

Frekvencijski opseg: 119 - 135 kHz

Maksimalna radio-frekvencijska snaga: 55dB μ A/m @10m

Me anë të këtij dokumenti, TOYOTA MOTOR CORPORATION deklaron se tipi i radiopajisjes TMLF19T-1 është në përputhje me Direktivën 2014/53/EU.

Teksti i plotë i deklaratës së konformitetit të Bashkimit Evropian është i disponueshëm në adresën e mëposhtme të internetit:

<http://www.tokai-rika.co.jp/pc>

Brezi i frekuencës: 119 - 135 kHz

Fuqia maksimale e radiofrekuencës: 55dB μ A/m @10m

TOYOTA MOTOR CORPORATION ovime izjavljuje da je radijska oprema tipa TMLF19T-1 u skladu s Direktivom 2014/53/EU.

Cjeloviti tekst EU izjave o sukladnosti dostupan je na sljedećoj internetskoj adresi:

<http://www.tokai-rika.co.jp/pc>

Frekvencijski pojas: 119 - 135 kHz

Maksimalna RF snaga: 55dB μ A/m @10m

Ovim TOYOTA MOTOR CORPORATION potvrđuje da je radio-oprema tipa TMLF19T-1 u skladu sa Direktivom 2014/53/EU.

Potpuni tekst EU deklaracije o usaglašenosti dostupan je na sledećoj internet adresi:

<http://www.tokai-rika.co.jp/pc>

Frekventni opseg: 119 - 135 kHz

Maksimalna radio-frekventna snaga: 55dB μ A/m @10m

TOYOTA MOTOR CORPORATION, işbu belgeyle telsiz cihazı türünün TMLF19T-1 2014/53/EU nolu Direktif ile uyumlu olduğunu beyan etmektedir.

AB uygunluk beyanının tam metnine aşağıdaki internet adresinden ulaşabilirsiniz:

<http://www.tokai-rika.co.jp/pc>

Frekans bandı: 119 - 135 kHz

Maksimum radyo frekans gücü: 55dB μ A/m @10m



Address: 1, Toyota-cho, Toyota, Aichi, 471-8572, Japan

► For vehicles sold in Ukraine

Справжнім TOYOTA MOTOR CORPORATION заявляє, що тип радіообладнання TMLF19T-1 відповідає Технічному регламенту радіообладнання;

КАБІНЕТ МІНІСТРІВ УКРАЇНИ ПОСТАНОВА №.355

Повний текст декларації про відповідність доступний на веб-сайті за такою адресою:

<http://www.tokai-rika.co.jp/pc>

Діапазон частот : 119 - 135 kHz

Максимальна потужність радіочастотного випромінювання :
55dB μ A/m @10m



Адреса: 1, Toyota-cho, Toyota, Aichi-ken, 471-8572, Japan

Toyota Safety Sense

Manufacturer Postal Address

ADC Automotive Distance Control Systems GmbH
Peter-Dornier-Strasse 10, 88131 Lindau, Germany

ОПРОСТЕНА ЕС ДЕКЛАРАЦИЯ ЗА СЪОТВЕТСТВИЕ

С настоящото ADC Automotive Distance Control Systems GmbH декларира, че този тип радиосъоръжение ARS5-B е в съответствие с Директива 2014/53/ЕС. Цялостният текст на ЕС декларацията за съответствие може да се намери на следния интернет адрес:

<http://continental.automotive-approvals.com/>

радиочестотната лента или ленти, в която или които работи радиосъоръжението: 76–77 GHz

максималната радиочестотна мощност, излъчвана в радиочестотната лента или ленти, в която или които работи радиосъоръжението.:
2.0 W (33dBm RMS EIRP)

<p>DECLARACIÓN UE DE CONFORMIDAD SIMPLIFICADA</p> <p>Por la presente, ADC Automotive Distance Control Systems GmbH declara que el tipo de equipo radioeléctrico ARS5-B es conforme con la Directiva 2014/53/UE. El texto completo de la declaración UE de conformidad está disponible en la dirección Internet siguiente: http://continental.automotive-approvals.com/</p> <p>Banda o bandas de frecuencia en las que opera el equipo radioeléctrico: 76–77 GHz</p> <p>Potencia máxima de radiofrecuencia transmitida en la banda o bandas de frecuencia en las que opera el equipo radioeléctrico: 2.0 W (33dBm RMS EIRP)</p>
<p>ZJEDNODUŠENÉ EU PROHLÁŠENÍ O SHODĚ</p> <p>Tímto ADC Automotive Distance Control Systems GmbH prohlašuje, že typ rádio-vého zařízení ARS5-B je v souladu se směrnicí 2014/53/EU. Úplné znění EU prohlášení o shodě je k dispozici na této internetové adrese: http://continental.automotive-approvals.com/</p> <p>Kmitočtové pásmo (kmitočtová pásma), v němž (v nichž) rádiové zařízení pracuje: 76–77 GHz</p> <p>Maximální radiofrekvenční výkon vysílaný v kmitočtovém pásmu (v kmitočtových pásmech), v němž (v nichž) je rádiové zařízení provozováno: 2.0 W (33dBm RMS EIRP)</p>
<p>FORENKLET EU-OVERENSSTEMMELSESERKLÆRING</p> <p>Hermed erklærer ADC Automotive Distance Control Systems GmbH, at radioudstyrstypen ARS5-B er i overensstemmelse med direktiv 2014/53/EU. EU-overensstemmelseserklæringens fulde tekst kan findes på følgende internetadresse: http://continental.automotive-approvals.com/</p> <p>Frekvensbånd, som radioudstyret fungerer på: 76–77 GHz</p> <p>Maksimal radiofrekvenseffekt, der udsendes i de frekvensbånd, som radioudstyret fungerer på: 2.0 W (33dBm RMS EIRP)</p>

<p>VEREINFACHTE EU-KONFORMITÄTSERKLÄRUNG Hiermit erklärt ADC Automotive Distance Control Systems GmbH, dass der Funkanlagentyp ARS5-B der Richtlinie 2014/53/EU entspricht. Der vollständige Text der EU-Konformitätserklärung ist unter der folgenden Internetadresse verfügbar: http://continental.automotive-approvals.com/</p> <p>Das Frequenzband oder die Frequenzbänder, in dem bzw. denen die Funkanlage betrieben wird: 76–77 GHz</p> <p>Die in dem Frequenzband oder den Frequenzbändern, in dem bzw. denen die Funkanlage betrieben wird, abgestrahlte maximale Sendeleistung: 2.0 W (33dBm RMS EIRP)</p>
<p>LIHTSUSTATUD ELI VASTAVUSDEKLARATSIOON Käesolevaga deklareerib ADC Automotive Distance Control Systems GmbH, et käesolev raadioseadme tüüp ARS5-B vastab direktiivi 2014/53/EL nõuetele. ELi vastavusdeklaratsiooni täielik tekst on kätesaadav järgmisel internetiaadressil: http://continental.automotive-approvals.com/</p> <p>Sagedusriba(d), millel raadioseade töötab: 76–77 GHz</p> <p>Raadioseadme töösagedus(t)el edastatav maksimaalne saatevõimsus: 2.0 W (33dBm RMS EIRP)</p>
<p>ΑΠΛΟΥΣΤΕΥΜΕΝΗ ΔΗΛΩΣΗ ΣΥΜΜΟΡΦΩΣΗΣ ΕΕ Με την παρούσα ο/η ADC Automotive Distance Control Systems GmbH, δηλώνει ότι ο ραδιοεξοπλισμός ARS5-B πληροί την οδηγία 2014/53/ΕΕ. Το πλήρες κείμενο της δήλωσης συμμόρφωσης ΕΕ διατίθεται στην ακόλουθη ιστοσελίδα στο διαδίκτυο: http://continental.automotive-approvals.com/</p> <p>Οι ζώνες συχνότητων στις οποίες λειτουργεί ο ραδιοεξοπλισμός: 76–77 GHz</p> <p>η μέγιστη ραδιοηλεκτρική ισχύς στις ζώνες συχνότητων στις οποίες λειτουργεί ο ραδιοεξοπλισμός: 2.0 W (33dBm RMS EIRP)</p>

<p>SIMPLIFIED EU DECLARATION OF CONFORMITY</p> <p>Hereby, ADC Automotive Distance Control Systems GmbH declares that the radio equipment type ARS5-B is in compliance with Directive 2014/53/EU. The full text of the EU declaration of conformity is available at the following internet address: http://continental.automotive-approvals.com/</p> <p>Frequency band(s) in which the radio equipment operates: 76–77 GHz</p> <p>Maximum radio-frequency power transmitted in the frequency band(s) in which the radio equipment operates: 2.0 W (33dBm RMS EIRP)</p>
<p>DECLARATION UE DE CONFORMITE SIMPLIFIEE</p> <p>Le soussigné, ADC Automotive Distance Control Systems GmbH, déclare que l'équipement radioélectrique du type ARS5-B est conforme à la directive 2014/53/UE. Le texte complet de la déclaration UE de conformité est disponible à l'adresse internet suivante: http://continental.automotive-approvals.com/</p> <p>Bandes de fréquences utilisées par l'équipement radioélectrique: 76–77 GHz</p> <p>Puissance de radiofréquence maximale transmise sur les bandes de fréquences utilisées par l'équipement radioélectrique: 2.0 W (33dBm RMS EIRP)</p>
<p>POJEDNOSTAVLJENA EU IZJAVA O SUKLADNOSTI</p> <p>ADC Automotive Distance Control Systems GmbH ovime izjavljuje da je radijska oprema tipa ARS5-B u skladu s Direktivom 2014/53/EU. Cjeloviti tekst EU izjave o sukladnosti dostupan je na sljedećoj internetskoj adresi:. http://continental.automotive-approvals.com/</p> <p>Frekvencijski pojas (frekvencijski pojasi) u kojem (kojima) radijska oprema radi: 76–77 GHz</p> <p>Najveća radiofrekvencijska snaga koja se prenosi u frekvencijskom pojasu (frekvencijskim pojasi) u kojem (kojima) radijska oprema radi: 2.0 W (33dBm RMS EIRP)</p>

<p>DICHIARAZIONE DI CONFORMITÀ UE SEMPLIFICATA Il fabbricante, ADC Automotive Distance Control Systems GmbH, dichiara che il tipo di apparecchiatura radio ARS5-B è conforme alla direttiva 2014/53/UE. Il testo completo della dichiarazione di conformità UE è disponibile al seguente indirizzo Internet: http://continental.automotive-approvals.com/</p> <p>Bande di frequenza di funzionamento dell'apparecchiatura radio: 76–77 GHz</p> <p>Massima potenza a radiofrequenza trasmessa nelle bande di frequenza in cui opera l'apparecchiatura radio: 2.0 W (33dBm RMS EIRP)</p>
<p>VIENKĀRŠOTA ES ATBILSTĪBAS DEKLARĀCIJA Ar šo ADC Automotive Distance Control Systems GmbH deklarē, ka radioiekārta ARS5-B atbilst Direktīvai 2014/53/ES. Pilns ES atbilstības deklarācijas teksts ir pieejams šādā interneta vietnē: http://continental.automotive-approvals.com/</p> <p>Frekvenču joslu(-as), kurā(-ās) radioiekārtas darbojas: 76–77 GHz</p> <p>Frekvenču joslā(-ās), kurā(-ās) darbojas radioiekārtas, maksimālo pārraidītā signāla jaudu.: 2.0 W (33dBm RMS EIRP)</p>
<p>SUPAPRASTINTA ES ATITIKTIES DEKLARĀCIJA Aš, ADC Automotive Distance Control Systems GmbH, patvirtinu, kad radio ierīcību tipa ARS5-B atitinka Direktīvu 2014/53/ES. Visas ES atitikties deklarācijas teksts pieņemams šīu interneta adresu: http://continental.automotive-approvals.com/</p> <p>Dažņu juosta (-os), kurioje (-iose) veikia radijo ierīciniai: 76–77 GHz</p> <p>Didžiausia radijo dažņu galia, perduodama toje (tose) dažņu juostoje (-ose), kurioje (-iose) veikia radijo ierīciniai: 2.0 W (33dBm RMS EIRP)</p>

EGYSZERŰSÍTETT EU-MEGFELELŐSÉGI NYILATKOZAT

ADC Automotive Distance Control Systems GmbH igazolja, hogy a ARS5-B típusú rádióberendezés megfelel a 2014/53/EU irányelvnek. Az EU-megfelelőségi nyilatkozat teljes szövege elérhető a következő internetes címen::
<http://continental.automotive-approvals.com/>

Az(ok) a frekvenciasáv(ok), amely(ek)en a rádióberendezés működik: 76–77 GHz

Az abban a frekvenciasávban vagy azokban a frekvenciasávokban továbbított maximális teljesítmény, amely(ek)ben a rádióberendezés üzemel: 2.0 W (33dBm RMS EIRP)

DIKJARAZZJONI SSIMPLIFIKATA TA' KONFORMITÀ TAL-UE

B'dan, ADC Automotive Distance Control Systems GmbH, niddikjara li dan it-tip ta' tagħmir tar-radju ARS5-B huwa konformi mad-Direttiva 2014/53/UE. It-test kollu tad-dikjarazzjoni ta' konformità tal-UE huwa disponibbli f'dan l-indirizz tal-Internet li ġej:
<http://continental.automotive-approvals.com/>

Il-medda/meded tal-frekwenza li jaħdem fihom it-tagħmir tar-radju: 76–77 GHz

Il-potenza massima tal-frekwenza tar-radju trażmessa fil-medda/meded tal-frekwenza li jaħdem fihom it-tagħmir tar-radju: 2.0 W (33dBm RMS EIRP)

VEREENVOUDIGDE EU-CONFORMITEITSVERKLARING

Hierbij verklaar ik, ADC Automotive Distance Control Systems GmbH, dat het type radioapparatuur ARS5-B conform is met Richtlijn 2014/53/EU. De volledige tekst van de EU-conformiteitsverklaring kan worden geraadpleegd op het volgende internetadres:
<http://continental.automotive-approvals.com/>

Frequentieband(en) waarin de radioapparatuur functioneert: 76–77 GHz

Maximaal radiofrequent vermogen uitgezonden in de frequentieband(en) waarin de radioapparatuur functioneert: 2.0 W (33dBm RMS EIRP)

<p>UPROSZCZONA DEKLARACJA ZGODNOŚCI UE</p> <p>ADC Automotive Distance Control Systems GmbH niniejszym oświadcza, że typ urządzenia radiowego ARS5-B jest zgodny z dyrektywą 2014/53/UE. Pełny tekst deklaracji zgodności UE jest dostępny pod następującym adresem internetowym: http://continental.automotive-approvals.com/</p> <p>Zakresu(-ów) częstotliwości, w którym (których) pracuje urządzenie radiowe: 76–77 GHz</p> <p>Maksymalnej mocy częstotliwości radiowej emitowanej w zakresie(-ach) częstotliwości, w którym (których) pracuje urządzenie radiowe: 2.0 W (33dBm RMS EIRP)</p>
<p>DECLARAÇÃO UE DE CONFORMIDADE SIMPLIFICADA</p> <p>O(a) abaixo assinado(a) ADC Automotive Distance Control Systems GmbH declara que o presente tipo de equipamento de rádio ARS5-B está em conformidade com a Diretiva 2014/53/UE. O texto integral da declaração de conformidade está disponível no seguinte endereço de Internet: http://continental.automotive-approvals.com/</p> <p>A(s) banda(s) de frequências em que o equipamento de rádio funciona: 76–77 GHz</p> <p>A potência máxima de radiofrequências transmitida na(s) banda(s) de frequências em que o equipamento de rádio funciona: 2.0 W (33dBm RMS EIRP)</p>
<p>DECLARAȚIA UE DE CONFORMITATE SIMPLIFICATĂ</p> <p>Prin prezenta, ADC Automotive Distance Control Systems GmbH declară că tipul de echipamente radio ARS5-B este în conformitate cu Directiva 2014/53/UE. Textul integral al declarației UE de conformitate este disponibil la următoarea adresă internet: http://continental.automotive-approvals.com/</p> <p>Banda (benzile) de frecvențe în care funcționează echipamentul radio: 76–77 GHz</p> <p>Puterea maximă de radiofrecvență transmisă în banda (benzile) de frecvențe în care funcționează echipamentul radio: 2.0 W (33dBm RMS EIRP)</p>

<p>ZJEDNODUŠENÉ EÚ VYHLÁSENIE O ZHODE ADC Automotive Distance Control Systems GmbH týmto vyhlasuje, že rádiové zariadenie typu ARS5-B je v súlade so smernicou 2014/53/EÚ. Úplné EÚ vyhlásenie o zhode je k dispozícii na tejto internetovej adrese: http://continental.automotive-approvals.com/</p> <p>Frekvenčné pásmo resp. pásma, v ktorých rádiové zariadenie pracuje: 76–77 GHz</p> <p>Maximálny vysokofrekvenčný výkon prenášaný vo frekvenčnom pásme, resp. pásmach, v ktorých rádiové zariadenie pracuje: 2.0 W (33dBm RMS EIRP)</p>
<p>POENOSTAVLJENA IZJAVA EU O SKLADNOSTI ADC Automotive Distance Control Systems GmbH potvrdzuje, že typ rádiového zariadenia ARS5-B je v súlade s Direktívou 2014/53/EÚ. Celotné besedilo izjavy EU o skladnosti je na voljo na nasledujúcom internetovom adrese: http://continental.automotive-approvals.com/</p> <p>Frekvenčný pas ali pasovi, na katerih deluje radijska oprema: 76–77 GHz</p> <p>Največja energija za radijsko frekvenco, preneseno po frekvenčnom pasu ali pasovih, na katerih radijska oprema deluje: 2.0 W (33dBm RMS EIRP)</p>
<p>YKSINKERTAISTETTU EU-VAATIMUSTENMUKAISUUSVAKUUTUS ADC Automotive Distance Control Systems GmbH vakuuttaa, että radiolaitetyyppi ARS5-B on direktiivin 2014/53/EU mukainen. EU-vaatimustenmukaisuusvakuutuksen täysimittainen teksti on saatavilla seuraavaa varten internetosoitteesta: http://continental.automotive-approvals.com/</p> <p>Radiotaajuudet, joilla radiolaitte toimii: 76–77 GHz</p> <p>Suurin mahdollinen lähetysteho radiotaajuuksilla, joilla radiolaitte toimii: 2.0 W (33dBm RMS EIRP)</p>

<p>FÖRENKLAD EU-FÖRSÄKRAN OM ÖVERENSSTÄMMELSE Härmed försäkrar ADC Automotive Distance Control Systems GmbH att denna typ av radioutrustning ARS5-B överensstämmer med direktiv 2014/53/EU. Den fullständiga texten till EU-försäkran om överensstämmelse finns på följande webbadress: http://continental.automotive-approvals.com/</p> <p>Det eller de frekvensband där radioutrustningen arbetar: 76–77 GHz</p> <p>Den maximala radiofrekvenseffekt som överförs inom det eller de frekvensband där radioutrustningen arbetar: 2.0 W (33dBm RMS EIRP)</p>
<p>EINFÖLDUÐ ESB SAMRÆMISYFIRLÝSING Hér með lýsir ADC Automotive Distance Control Systems GmbH því yfir, að fjarskiptabúnaðurinn að gerð ARS5-B er í samræmi við tilskipun 2014/53/ ESB. Textinn í fullri lengd um Samræmisyfirlýsingu ESB er að gengilegur á eftirfarandi veffangi: http://continental.automotive-approvals.com/</p> <p>Bandbreidd(ir), sem fjarskiptabúnaðurinn starfar í: 76–77 GHz</p> <p>Hámarks fjarskiptatíðni sendistyrkleika í bandbreiddinni/bandbreiddunum sem fjarskiptabúnaðurinn starfar í: 2.0 W (33dBm RMS EIRP)</p>
<p>BASİTLEŞTİRİLMİŞ AB UYGUNLUK BEYANI İşbu belge ile, ADC Automotive Distance Control Systems GmbH şirketi ARS5-B tipi radyo ekipmanının 2014/53/AB sayılı direktife uygun olduğunu beyan eder. AB uygunluk beyanının tam metni aşağıdaki İnternet adresinde mevcut-tur: http://continental.automotive-approvals.com/</p> <p>Radyo cihazının çalıştığı frekans bandı/bantları: 76–77 GHz</p> <p>Radyo ekipmanının çalıştığı frekans bandında/bantlarında iletilen maksimum radyo frekansı gücü: 2.0 W (33dBm RMS EIRP)</p>

- For vehicles sold in Ukraine



СПРОЩЕНА ДЕКЛАРАЦІЯ про відповідність
справжнім (найменування виробника ADC Automotive Distance Control Systems GmbH) заявляє, що тип радіобладнання (позначення типу радіобладнання ARS5-B) відповідає Технічному регламенту радіобладнання;
повний текст декларації про відповідність доступний на веб-сайті за такою адресою: <http://continental.automotive-approvals.com/>

найменування та адресу виробника
АДС Автомобілів Дістанс Контрол Системс ГмбХ
Пітер-Дорнієр-Штрассе 10, 88131, Ліндау, Німеччина
(ADC Automotive Distance Control Systems GmbH
Peter-Dornier-Strasse 10, 88131, Lindau, Germany)

СПРОЩЕНА ДЕКЛАРАЦІЯ ЄС ПРО ВІДПОВІДНІСТЬ
Цим ADC Automotive Distance Control Systems GmbH заявляє, що радіобладнання типу ARS5-B відповідає вимогам Директиви 2014/53/EU. Повний текст декларації ЄС про відповідність доступний за наступною адресою в мережі Інтернет:
<http://continental.automotive-approvals.com/>
Частотний діапазон(-и), в якому працює радіобладнання: 76–77 ГГц
Максимальна потужність радіочастотного сигналу, що передається у частотному діапазоні(-ах), в якому працює радіобладнання:
2.0 Вт (33 дБм) Пікова ефективна потужність випромінювання

ARS5-B has been registered with: UA RF: 1CONT0008

- For vehicles sold in Serbia



- ▶ For vehicles sold in South Africa



Blind Spot Monitor**Manufacturer Postal Address**

ADC Automotive Distance Control Systems GmbH
Peter-Dornier-Strasse 10, 88131 Lindau, Germany

ОПРОСТЕНА ЕС ДЕКЛАРАЦИЯ ЗА СЪОТВЕТСТВИЕ

С настоящото ADC Automotive Distance Control Systems GmbH декларира, че този тип радиосъоръжение SRR3-A е в съответствие с Директива 2014/53/ЕС. Цялостният текст на ЕС декларацията за съответствие може да се намери на следния интернет адрес: <http://continental.automotive-approvals.com/>

радиочестотната лента или ленти, в която или които работи радиосъоръжението: 24.05–24.25 GHz

максималната радиочестотна мощност, излъчвана в радиочестотната лента или ленти, в която или които работи радиосъоръжението: 100mW (20 dBm) Peak EIRP

DECLARACIÓN UE DE CONFORMIDAD SIMPLIFICADA

Por la presente, ADC Automotive Distance Control Systems GmbH declara que el tipo de equipo radioeléctrico SRR3-A es conforme con la Directiva 2014/53/UE. El texto completo de la declaración UE de conformidad está disponible en la dirección Internet siguiente: <http://continental.automotive-approvals.com/>

Banda o bandas de frecuencia en las que opera el equipo radioeléctrico: 24.05–24.25 GHz

Potencia máxima de radiofrecuencia transmitida en la banda o bandas de frecuencia en las que opera el equipo radioeléctrico: 100mW (20 dBm) Peak EIRP

ZJEDNODUŠENÉ EU PROHLÁŠENÍ O SHODĚ

Tímto ADC Automotive Distance Control Systems GmbH prohlašuje, že typ rádio-vého zařízení SRR3-A je v souladu se směrnicí 2014/53/EU. Úplné znění EU prohlášení o shodě je k dispozici na této internetové adrese:

<http://continental.automotive-approvals.com/>

Kmitočtové pásmo (kmitočtová pásma), v němž (v nichž) rádiové zařízení pracuje: 24.05–24.25 GHz

Maximální radiofrekvenční výkon vysílaný v kmitočtovém pásmu (v kmitočtových pásmech), v němž (v nichž) je rádiové zařízení provozováno: 100mW (20 dBm) Peak EIRP

FORENKLET EU-OVERENSSTEMMELSESERKLÆRING

Hermed erklærer ADC Automotive Distance Control Systems GmbH, at radioudstyrstypen SRR3-A er i overensstemmelse med direktiv 2014/53/EU. EU-overensstemmelseserklæringens fulde tekst kan findes på følgende internetadresse:

<http://continental.automotive-approvals.com/>

Frekvensbånd, som radioudstyret fungerer på: 24.05–24.25 GHz

Maksimal radiofrekvenseffekt, der udsendes i de frekvensbånd, som radioudstyret fungerer på: 100mW (20 dBm) Peak EIRP

VEREINFACHTE EU-KONFORMITÄTSEKTLÄRUNG

Hiermit erklärt ADC Automotive Distance Control Systems GmbH, dass der Funkanlagentyp SRR3-A der Richtlinie 2014/53/EU entspricht. Der vollständige Text der EU-Konformitätserklärung ist unter der folgenden Internetadresse verfügbar:

<http://continental.automotive-approvals.com/>

Das Frequenzband oder die Frequenzbänder, in dem bzw. denen die Funkanlage betrieben wird: 24.05–24.25 GHz

Die in dem Frequenzband oder den Frequenzbändern, in dem bzw. denen die Funkanlage betrieben wird, abgestrahlte maximale Sendeleistung: 100mW (20 dBm) Peak EIRP

LIHTSUSTATUD ELI VASTAVUSDEKLARATSIOON

Käesolevaga deklareerib ADC Automotive Distance Control Systems GmbH, et käesolev raadioseadme tüüp SRR3-A vastab direktiivi 2014/53/EL nõuetele. ELi vastavusdeklaratsiooni täielik tekst on kättesaadav järgmisel internetiaadressil:
<http://continental.automotive-approvals.com/>

Sagedusriba(d), millel raadioseade töötab: 24.05–24.25 GHz

Raadioseadme töösagedus(t)el edastatav maksimaalne saatevõimsus: 100mW (20 dBm) Peak EIRP

ΑΠΛΟΥΣΤΕΥΜΕΝΗ ΔΗΛΩΣΗ ΣΥΜΜΟΡΦΩΣΗΣ ΕΕ

Με την παρούσα ο/η ADC Automotive Distance Control Systems GmbH, δηλώνει ότι ο ραδιοεξοπλισμός SRR3-A πληροί την οδηγία 2014/53/ΕΕ. Το πλήρες κείμενο της δήλωσης συμμόρφωσης ΕΕ διατίθεται στην ακόλουθη ιστοσελίδα στο διαδίκτυο:
<http://continental.automotive-approvals.com/>

Οι ζώνες συχνοτήτων στις οποίες λειτουργεί ο ραδιοεξοπλισμός: 24.05–24.25 GHz

η μέγιστη ραδιοηλεκτρική ισχύς στις ζώνες συχνοτήτων στις οποίες λειτουργεί ο ραδιοεξοπλισμός: 100mW (20 dBm) Peak EIRP

SIMPLIFIED EU DECLARATION OF CONFORMITY

Hereby, ADC Automotive Distance Control Systems GmbH declares that the radio equipment type SRR3-A is in compliance with Directive 2014/53/EU. The full text of the EU declaration of conformity is available at the following internet address:
<http://continental.automotive-approvals.com/>

Frequency band(s) in which the radio equipment operates: 24.05–24.25 GHz

Maximum radio-frequency power transmitted in the frequency band(s) in which the radio equipment operates: 100mW (20 dBm) Peak EIRP

DECLARATION UE DE CONFORMITE SIMPLIFIEE

Le soussigné, ADC Automotive Distance Control Systems GmbH, déclare que l'équipement radioélectrique du type SRR3-A est conforme à la directive 2014/53/UE. Le texte complet de la déclaration UE de conformité est disponible à l'adresse internet suivante:
<http://continental.automotive-approvals.com/>

Bandes de fréquences utilisées par l'équipement radioélectrique: 24.05–24.25 GHz

Puissance de radiofréquence maximale transmise sur les bandes de fréquences utilisées par l'équipement radioélectrique: 100mW (20 dBm) Peak EIRP

POJEDNOSTAVLJENA EU IZJAVA O SUKLADNOSTI

ADC Automotive Distance Control Systems GmbH ovime izjavljuje da je radijska oprema tipa SRR3-A u skladu s Direktivom 2014/53/EU. Cjeloviti tekst EU izjave o sukladnosti dostupan je na sljedećoj internetskoj adresi:
<http://continental.automotive-approvals.com/>

Frekvencijski pojas (frekvencijski pojasi) u kojem (kojima) radijska oprema radi: 24.05–24.25 GHz

Najveća radiofrekvencijska snaga koja se prenosi u frekvencijskom pojasu (frekvencijskim pojasi) u kojem (kojima) radijska oprema radi: 100mW (20 dBm) Peak EIRP

DICHIARAZIONE DI CONFORMITÀ UE SEMPLIFICATA

Il fabbricante, ADC Automotive Distance Control Systems GmbH, dichiara che il tipo di apparecchiatura radio SRR3-A è conforme alla direttiva 2014/53/UE. Il testo completo della dichiarazione di conformità UE è disponibile al seguente indirizzo Internet:
<http://continental.automotive-approvals.com/>

Bande di frequenza di funzionamento dell'apparecchiatura radio: 24.05–24.25 GHz

Massima potenza a radiofrequenza trasmessa nelle bande di frequenza in cui opera l'apparecchiatura radio: 100mW (20 dBm) Peak EIRP

VIENKĀRŠOTA ES ATBILSTĪBAS DEKLARĀCIJA

Ar šo ADC Automotive Distance Control Systems GmbH deklarē, ka radioiekārta SRR3-A atbilst Direktīvai 2014/53/ES. Pilns ES atbilstības deklarācijas teksts ir pieejams šādā interneta vietnē:
<http://continental.automotive-approvals.com/>

Frekvenču joslu(-as), kurā(-ās) radioiekārtas darbojas: 24.05–24.25 GHz

Frekvenču joslā(-ās), kurā(-ās) darbojas radioiekārtas, maksimālo pārraidītā signāla jaudu.: 100mW (20 dBm) Peak EIRP

SUPAPRĀSTINTA ES ATITIKTĪES DEKLARĀCIJA

Aš, ADC Automotive Distance Control Systems GmbH, patvirtinu, kad radio ierīcību tipus SRR3-A atbilst Direktīvai 2014/53/ES. Visas ES atbilstības deklarācijas teksts pieejams šī interneta adresē:
<http://continental.automotive-approvals.com/>

Dažņu josla (-os), kurā(-ās) veic radio ierīcības: 24.05–24.25 GHz

Liela radio dažņu jauda, izmantojot to (-os) dažņu joslu (-os), kurā(-ās) veic radio ierīcības: 100mW (20 dBm) Peak EIRP

EGYSZERŰSÍTETT EU-MEGFELELŐSÉGI NYILATKOZAT

ADC Automotive Distance Control Systems GmbH igazolja, hogy a SRR3-A típusú rádióberendezés megfelel a 2014/53/EU irányelvnek. Az EU-megfelelőségi nyilatkozat teljes szövege elérhető a következő internetes címen:.
<http://continental.automotive-approvals.com/>

Az(ok) a frekvenciasáv(ok), amely(ek)en a rádióberendezés működik: 24.05–24.25 GHz

Az abban a frekvenciasávban vagy azokban a frekvenciasávokban továbbított maximális teljesítmény, amely(ek)ben a rádióberendezés üzemel: 100mW (20 dBm) Peak EIRP

<p>DIKJARAZZJONI SSIMPLIFIKATA TA' KONFORMITÀ TAL-UE B'dan, ADC Automotive Distance Control Systems GmbH, niddikjara li dan it-tip ta' tagħmir tar-radju SRR3-A huwa konformi mad-Direttiva 2014/53/UE. It-test kollu tad-dikjarazzjoni ta' konformità tal-UE huwa disponibbli f'dan l-indirizz tal-Internet li ġej: http://continental.automotive-approvals.com/</p> <p>Il-medda/meded tal-frekwenza li jaħdem fihom it-tagħmir tar-radju: 24.05–24.25 GHz</p> <p>Il-potenza massima tal-frekwenza tar-radju trażmessa fil-medda/meded tal-frekwenza li jaħdem fihom it-tagħmir tar- radju: 100mW (20 dBm) Peak EIRP</p>
<p>VEREENVOUDIGDE EU-CONFORMITEITSVERKLARING Hierbij verklaar ik, ADC Automotive Distance Control Systems GmbH, dat het type radioapparatuur SRR3-A conform is met Richtlijn 2014/53/EU. De volledige tekst van de EU-conformiteitsverklaring kan worden geraadpleegd op het volgende internetadres: http://continental.automotive-approvals.com/</p> <p>Frequentieband(en) waarin de radioapparatuur functioneert: 24.05–24.25 GHz</p> <p>Maximaal radiofrequent vermogen uitgezonden in de frequentieband(en) waarin de radioapparatuur functioneert: 100mW (20 dBm) Peak EIRP</p>
<p>UPROSZCZONA DEKLARACJA ZGODNOŚCI UE ADC Automotive Distance Control Systems GmbH niniejszym oświadcza, że typ urządzenia radiowego SRR3-A jest zgodny z dyrektywą 2014/53/UE. Pełny tekst deklaracji zgodności UE jest dostępny pod następującym adresem internetowym: http://continental.automotive-approvals.com/</p> <p>Zakresu(-ów) częstotliwości, w którym (których) pracuje urządzenie radiowe: 24.05–24.25 GHz</p> <p>Maksymalnej mocy częstotliwości radiowej emitowanej w zakresie(-ach) częstotliwości, w którym (których) pracuje urządzenie radiowe: 100mW (20 dBm) Peak EIRP</p>

DECLARAÇÃO UE DE CONFORMIDADE SIMPLIFICADA

O(a) abaixo assinado(a) ADC Automotive Distance Control Systems GmbH declara que o presente tipo de equipamento de rádio SRR3-A está em conformidade com a Diretiva 2014/53/UE. O texto integral da declaração de conformidade está disponível no seguinte endereço de Internet:

<http://continental.automotive-approvals.com/>

A(s) banda(s) de frequências em que o equipamento de rádio funciona:
24.05–24.25 GHz

A potência máxima de radiofrequências transmitida na(s) banda(s) de frequências em que o equipamento de rádio funciona: 100mW (20 dBm)
Peak EIRP

DECLARAȚIA UE DE CONFORMITATE SIMPLIFICATĂ

Prin prezenta, ADC Automotive Distance Control Systems GmbH declară că tipul de echipamente radio SRR3-A este în conformitate cu Directiva 2014/53/UE. Textul integral al declarației UE de conformitate este disponibil la următoarea adresă în-ternet:

<http://continental.automotive-approvals.com/>

Banda (benzile) de frecvențe în care funcționează echipamentul radio:
24.05–24.25 GHz

Puterea maximă de radiofrecvență transmisă în banda (benzile) de frecvențe în care funcționează echipamentul radio: 100mW (20 dBm)
Peak EIRP

ZJEDNODUŠENÉ EÚ VYHLÁSENIE O ZHODE

ADC Automotive Distance Control Systems GmbH týmto vyhlasuje, že rádiové zariadenie typu SRR3-A je v súlade so smernicou 2014/53/EÚ. Úplné EÚ vyhlásenie o zhode je k dispozícii na tejto internetovej adrese:
<http://continental.automotive-approvals.com/>

Frekvenčné pásmo resp. pásma, v ktorých rádiové zariadenie pracuje:
24.05–24.25 GHz

Maximálny vysokofrekvenčný výkon prenášaný vo frekvenčnom pásme, resp. pásmach, v ktorých rádiové zariadenie pracuje: 100mW (20 dBm)
Peak EIRP

POENOSTAVLJENA IZJAVA EU O SKLADNOSTI

ADC Automotive Distance Control Systems GmbH potrjuje, da je tip radijske opreme SRR3-A skladen z Direktivo 2014/53/EU. Celotno besedilo izjave EU o skladnosti je na voljo na naslednjem spletnem naslovu:

<http://continental.automotive-approvals.com/>

Frekvenčni pas ali pasovi, na katerih deluje radijska oprema: 24.05–24.25 GHz

Največja energija za radijsko frekvenco, preneseno po frekvenčnem pasu ali pasovih, na katerih radijska oprema deluje: 100mW (20 dBm) Peak EIRP

YKSINKERTAISTETTU EU-VAATIMUSTENMUKAISUUSVAKUUTUS

ADC Automotive Distance Control Systems GmbH vakuuttaa, että radiolaitetyyppi SRR3-A on direktiivin 2014/53/EU mukainen. EU-vaatimustenmukaisuusvakuutuksen täysimittainen teksti on saatavilla seuraavassa internetosoitteessa:

<http://continental.automotive-approvals.com/>

Radiotaajuudet, joilla radiolaitte toimii: 24.05–24.25 GHz

Suurin mahdollinen lähetysteho radiotaajuuksilla, joilla radiolaitte toimii: 100mW (20 dBm) Peak EIRP

FÖRENKLAD EU-FÖRSÄKRAN OM ÖVERENSSTÄMMELSE

Härmed försäkrar ADC Automotive Distance Control Systems GmbH att denna typ av radioutrustning SRR3-A överensstämmer med direktiv 2014/53/EU. Den fullständiga texten till EU-försäkran om överensstämmelse finns på följande webbadress:

<http://continental.automotive-approvals.com/>

Det eller de frekvensband där radioutrustningen arbetar: 24.05–24.25 GHz

Den maximala radiofrekvensseffekt som överförs inom det eller de frekvensband där radioutrustningen arbetar: 100mW (20 dBm) Peak EIRP

EINFÖLDUÐ ESB SAMRÆMISYFIRLÝSING

Hér með lýsir ADC Automotive Distance Control Systems GmbH því yfir, að fjarskiptabúnaðurinn að gerð SRR3-A er í samræmi við tilskipun 2014/53/ ESB. Textinn í fullri lengd um Samræmisyfirlýsingu ESB er að gengilegur á eftirfarandi veffangi:
<http://continental.automotive-approvals.com/>

Bandbreidd(ir), sem fjarskiptabúnaðurinn starfar í: 24.05–24.25 GHz

Hámarks fjarskiptatíðni sendistyrkleika í bandbreiddinni/bandbreiddunum sem fjarskiptabúnaðurinn starfar í: 100mW (20 dBm) Peak EIRP

BASÍTLEŞTÍRILMIŞ AB UYGUNLUK BEYANI

İşbu belge ile, ADC Automotive Distance Control Systems GmbH şirketi SRR3-A tipi radyo ekipmanının 2014/53/AB sayılı direktife uygun olduğ unu beyan eder. AB uygunluk beyanının tam metni aşağıdaki İnternet adresinde mevcuttur:
<http://continental.automotive-approvals.com/>

Radyo cihazının çalıştığı frekans bandı/bantları: 24.05–24.25 GHz

Radyo ekipmanının çalıştığı frekans bandında/bantlarında iletilen maksimum radyo frekansı gücü: 100mW (20 dBm) Peak EIRP

- For vehicles sold in Ukraine



СПРОЩЕНА ДЕКЛАРАЦІЯ про відповідність
справжнім (найменування виробника ADC Automotive Distance Control Systems GmbH) заявляє, що тип радіообладнання (позначення типу радіообладнання SRR3-A) відповідає Технічному регламенту радіообладнання;
повний текст декларації про відповідність доступний на веб-сайті за такою адресою: <http://continental.automotive-approvals.com/>

найменування та адресу виробника
АДС Автомобілів Дістанс Контрол Системс ГмбХ
Пітер-Дорнієр-Штрассе 10, 88131, Ліндау, Німеччина
(ADC Automotive Distance Control Systems GmbH
Peter-Dornier-Strasse 10, 88131, Lindau, Germany)

СПРОЩЕНА ДЕКЛАРАЦІЯ ЄС ПРО ВІДПОВІДНІСТЬ
Цим ADC Automotive Distance Control Systems GmbH заявляє, що радіообладнання типу SRR3-A відповідає вимогам Директиви 2014/53/EU. Повний текст декларації ЄС про відповідність доступний за наступною адресою в мережі Інтернет:
<http://continental.automotive-approvals.com/>
Частотний діапазон(-и), в якому працює радіообладнання: 24.05–24.25 ГГц
Максимальна потужність радіочастотного сигналу, що передається у частотному діапазоні(-ах), в якому працює радіообладнання:
100 мВт (20 дБм) Пікова ефективна потужність випромінювання

SRR3-A has been registered with: UA RF: 1CONT 0006

- For vehicles sold in Serbia



Tires

• Manufacturer's name: PACIFIC INDUSTRIAL CO., LTD.

• Registered trademark:



This trademark is registered in the following countries:

UK, Italy, Austria, Greece, Germany, France, Belgium,
the Netherlands, Luxembourg, Portugal.

• Manufacturer's address:

1300-1 Yokoi, Godo-cho, Anpachi-gun, Gifu, 503-2397 JAPAN

• Operating frequency band: 433.05 — 434.79MHz

• Maximum radio-frequency power: 100dB μ V/m@3m(Radiated)

Hereby, PACIFIC INDUSTRIAL CO., LTD. declares that the radio equipment type PMV-E100 is in compliance with Directive 2014/53/EU.

The full text of the EU declaration of conformity is available at the following internet address:

<https://www.pacific-ind.co.jp/eng/products/car/tpms/doc/>

PACIFIC INDUSTRIAL CO., LTD. vakuuttaa, että radiolaitetyyppi PMV-E100 on direktiivin 2014/53/EU mukainen.

EU-vaatimustenmukaisuusvakuutuksen täysimittainen teksti on saatavilla seuraavassa internetosoitteessa:

<https://www.pacific-ind.co.jp/eng/products/car/tpms/doc/>

Hierbij verklaar ik, PACIFIC INDUSTRIAL CO., LTD., dat het type radioapparatuur PMV-E100 conform is met Richtlijn 2014/53/EU.

De volledige tekst van de EU-conformiteitsverklaring kan worden geraadpleegd op het volgende internetadres:

<https://www.pacific-ind.co.jp/eng/products/car/tpms/doc/>

Le soussigné, PACIFIC INDUSTRIAL CO., LTD., déclare que l'équipement radioélectrique du type PMV-E100 est conforme à la directive 2014/53/UE.

Le texte complet de la déclaration UE de conformité est disponible à l'adresse internet suivante:

<https://www.pacific-ind.co.jp/eng/products/car/tpms/doc/>

Härmed försäkrar PACIFIC INDUSTRIAL CO., LTD. att denna typ av radioutrustning PMV-E100

överensstämmer med direktiv 2014/53/EU.

Den fullständiga texten till EU-försäkran om överensstämmelse finns på följande webbadress:

<https://www.pacific-ind.co.jp/eng/products/car/tpms/doc/>

Hermed erklærer PACIFIC INDUSTRIAL CO., LTD., at radioudstyrstypen PMV-E100 er i

overensstemmelse med direktiv 2014/53/EU.

EU-overensstemmelseserklæringens fulde tekst kan findes på følgende internetadresse:

<https://www.pacific-ind.co.jp/eng/products/car/tpms/doc/>

Hiermit erklährt PACIFIC INDUSTRIAL CO., LTD., dass der Funkanlagentyp PMV-E100 der Richtlinie 2014/53/EU entspricht.

Der vollständige Text der EU-Konformitätserklärung ist unter der folgenden Internetadresse verfügbar:

<https://www.pacific-ind.co.jp/eng/products/car/tpms/doc/>

Με την παρούσα ο/η PACIFIC INDUSTRIAL CO., LTD., δηλώνει ότι ο ραδιοεξοπλισμός PMV-E100 πληροί την οδηγία 2014/53/ΕΕ. Το πλήρες κείμενο της δήλωσης συμμόρφωσης ΕΕ διατίθεται στην ακόλουθη ιστοσελίδα στο διαδίκτυο:

<https://www.pacific-ind.co.jp/eng/products/car/tpms/doc/>

Il fabbricante, PACIFIC INDUSTRIAL CO., LTD., dichiara che il tipo di apparecchiatura radio PMV-E100 è conforme alla direttiva 2014/53/UE.

Il testo completo della dichiarazione di conformità UE è disponibile al seguente indirizzo Internet:

<https://www.pacific-ind.co.jp/eng/products/car/tpms/doc/>

Por la presente, PACIFIC INDUSTRIAL CO., LTD. declara que el tipo de equipo radioeléctrico PMV-E100 es conforme con la Directiva 2014/53/UE.

El texto completo de la declaración UE de conformidad está disponible en la dirección Internet siguiente:

<https://www.pacific-ind.co.jp/eng/products/car/tpms/doc/>

O(a) abaixo assinado(a) PACIFIC INDUSTRIAL CO., LTD. declara que o presente tipo de equipamento de rádio PMV-E100 está em conformidade com a Diretiva 2014/53/UE.

O texto integral da declaração de conformidade está disponível no seguinte endereço de Internet:

<https://www.pacific-ind.co.jp/eng/products/car/tpms/doc/>

B'dan, PACIFIC INDUSTRIAL CO., LTD., niddikjara li dan it-tip ta' tagħmir tar-radju PMV-E100 huwa konformi mad-Direttiva 2014/53/UE.

It-test kollu tad-dikjarazzjoni ta' konformità tal-UE huwa disponibbli f'dan l-indirizz tal-Internet li ġej:

<https://www.pacific-ind.co.jp/eng/products/car/tpms/doc/>

Käesolevaga deklareerib PACIFIC INDUSTRIAL CO., LTD., et käesolev raadioseadme tüüp PMV-E100 vastab direktiivi 2014/53/EL nõuetele.

ELi vastavusdeklaratsiooni täielik tekst on kättesaadav järgmisel internetiaadressil:

<https://www.pacific-ind.co.jp/eng/products/car/tpms/doc/>

<p>PACIFIC INDUSTRIAL CO., LTD. igazolja, hogy a PMV-E100 típusú rádióberendezés megfelel a 2014/53/EU irányelvnek. Az EU-megfelelőségi nyilatkozat teljes szövege elérhető a következő internetes címen: https://www.pacific-ind.co.jp/eng/products/car/tpms/doc/</p>
<p>PACIFIC INDUSTRIAL CO., LTD. týmto vyhlasuje, že rádiové zariadenie typu PMV-E100 je v súlade so smernicou 2014/53/EÚ. Úplné EÚ vyhlásenie o zhode je k dispozícii na tejto internetovej adrese: https://www.pacific-ind.co.jp/eng/products/car/tpms/doc/</p>
<p>Týmto PACIFIC INDUSTRIAL CO., LTD. prohlašuje, že typ rádiového zařízení PMV-E100 je v souladu se směrnicí 2014/53/EU. Úplné znění EU prohlášení o shodě je k dispozici na této internetové adrese: https://www.pacific-ind.co.jp/eng/products/car/tpms/doc/</p>
<p>PACIFIC INDUSTRIAL CO., LTD. potrjuje, da je tip radijske opreme PMV-E100 skladen z Direktivo 2014/53/EU. Celotno besedilo izjave EU o skladnosti je na voljo na naslednjem spletnem naslovu: https://www.pacific-ind.co.jp/eng/products/car/tpms/doc/</p>
<p>Aš, PACIFIC INDUSTRIAL CO., LTD., patvirtinu, kad radijo įrenginių tipas PMV-E100 atitinka Direktyvą 2014/53/ES. Visas ES atitikties deklaracijos tekstas prieinamas šiuo interneto adresu: https://www.pacific-ind.co.jp/eng/products/car/tpms/doc/</p>

Ar šo PACIFIC INDUSTRIAL CO., LTD. deklarē, ka radioiekārtā PMV-E100 atbilst Direktīvai 2014/53/ES.

Pilns ES atbilstības deklarācijas teksts ir pieejams šādā interneta vietnē:

<https://www.pacific-ind.co.jp/eng/products/car/tpms/doc/>

PACIFIC INDUSTRIAL CO., LTD. niniejszym oświadcza, że typ urządzenia radiowego PMV-E100 jest zgodny z dyrektywą 2014/53/UE.

Pełny tekst deklaracji zgodności UE jest dostępny pod następującym adresem internetowym:

<https://www.pacific-ind.co.jp/eng/products/car/tpms/doc/>

Hér með lýsir PACIFIC INDUSTRIAL CO., LTD. yfir því að PMV-E100 er í samræmi við grunnkröfur og aðrar kröfur, sem gerðar eru í tilskipun 2014/53/EU.

Samræmisýfirlýsing er einnig aðgengileg á eftirfarandi vefsíðu:

<https://www.pacific-ind.co.jp/eng/products/car/tpms/doc/>

PACIFIC INDUSTRIAL CO., LTD. erklærer at PMV-E100 er i overensstemmelse med direktiv 2014/53/EU.

Samsvarserklæringen i fulltekst er tilgjengelig på følgende internettadresse:

<https://www.pacific-ind.co.jp/eng/products/car/tpms/doc/>

С настоящето PACIFIC INDUSTRIAL CO., LTD. декларира, че този тип радиосъоръжение PMV-E100 е в съответствие с Директива 2014/53/ЕС.

Цялостният текст на ЕС декларацията за съответствие може да се намери на следния интернет адрес:

<https://www.pacific-ind.co.jp/eng/products/car/tpms/doc/>

Prin prezenta, PACIFIC INDUSTRIAL CO., LTD. declară că tipul de echipamente radio PMV-E100 este în conformitate cu Directiva 2014/53/UE.

Textul integral al declarației UE de conformitate este disponibil la următoarea adresă internet:

<https://www.pacific-ind.co.jp/eng/products/car/tpms/doc/>

U ovom dokumentu, PACIFIC INDUSTRIAL CO., LTD. deklarira da je radio oprema model PMV-E100 usklađena sa Directive 2014/53/EU.

Cio tekst EU deklaracije usklađenosti dostupan je na slijedećoj internet adresi:

<https://www.pacific-ind.co.jp/eng/products/car/tpms/doc/>

Овим, PACIFIC INDUSTRIAL CO., LTD. изјављује да је радио опрема типа PMV-E100 усклађена са Directive 2014/53/EU.

Комплетан текст декларације ЕУ за усаглашеност доступан је на следећој веб адреси:

<https://www.pacific-ind.co.jp/eng/products/car/tpms/doc/>

PACIFIC INDUSTRIAL CO., LTD. ovime izjavljuje da je radijska oprema tipa PMV-E100 u skladu s Direktivom 2014/53/EU.

Cjeloviti tekst EU izjave o sukladnosti dostupan je na sljedećoj internetskoj adresi:

<https://www.pacific-ind.co.jp/eng/products/car/tpms/doc/>

Këtu, PACIFIC INDUSTRIAL CO., LTD. deklaronte se pajisja radio PMV-E100 është në përputhje me Directive 2014/53/EU.

Teksti i plotë i deklaratës së konformitetit të BE-së gjendet në adresën e mëposhtme të internetit:

<https://www.pacific-ind.co.jp/eng/products/car/tpms/doc/>

► For vehicles sold in Ukraine



- Модель: PMV-E100
- Виробник: Pacific Industrial Co., Ltd.

▪ Найменування та адреса виробника або його уповноваженого представника

Pacific Industrial Co., Ltd.
1300-1 Yokoi, Godo-cho, Anpachi-Gun, Gifu-Pref., 503-2397
Японія/Японія.

- Діапазон частот, МГц: 433,05 – 434,79
- Максимальна вихідна потужність передавача, мВт (дБм): 1,0 (0);

▪ Справжнім Pacific Industrial Co., Ltd. заявляє, що радіопередавач системи контролю тиску та температури в шинах автомобіля відповідає Технічному регламенту радіобладнання; повний текст декларації про відповідність доступний на веб-сайті за такою адресою:
<https://www.pacific-ind.co.jp//eng/products/car/tpms/doc/ukr/>

► For vehicles sold in Serbia



Jack**Manufacturer's Declaration of Conformity****Manufacturer:**

ARIKAN KRIKO A.Ş
Organize Sanayi Bölgesi Teknoloji Bul. NO:13 26110 ESKİŞEHİR / TURKEY

The EU Directives covered by this Declaration

2006 / 42 / EC Machinery Directive

The product covered by this declaration

JACK SUB-ASSY. PANTOGRAPH
model
0.8 ton , 1.1 ton

The basis on which conformity is being declared

The product identified above complies with the requirements of
the Machinery Directive
Directive above by meeting following standards

857 – ISO 8720

The technical documentation required to demonstrate that the product
meets the requirement the Machinery Directive has been compiled by
the signatory below and is available for inspection by the relevant
enforcement authorities.

A sample of the product has been tested by the manufacturer

Technical File No :2010 - TOYOTA JACK -ISO8720-1

The CE mark was first applied in:2010

Ahmet ARIKAN
General Manager

Signature :

Date of Issue : 26.02.2016

8

Vehicle specifications

Index

561

What to do if... (Troubleshooting)**562**
Alphabetical Index**565**

What to do if... (Troubleshooting)

If you have a problem, check the following before contacting any authorized Toyota retailer or Toyota authorized repairer, or any reliable repairer.

The doors cannot be locked, unlocked, opened or closed



You lose your keys

- If you lose your keys or mechanical keys, new genuine keys or mechanical keys can be made by any authorized Toyota retailer or Toyota authorized repairer, or any reliable repairer. (→P.407)
- Vehicles with smart entry & start system: If you lose your electronic keys, the risk of vehicle theft increases significantly. Contact any authorized Toyota retailer or Toyota authorized repairer, or any reliable repairer immediately. (→P.407)



The doors cannot be locked or unlocked

- Is the key battery weak or depleted? (→P.351)
- Vehicles with a smart entry & start system: Is the power switch in ON?

When locking the doors, turn the power

switch off. (→P.177)

- Vehicles with a smart entry & start system: Is the electronic key left inside the vehicle?

When locking the doors, make sure that you have the electronic key on your person.

- The function may not operate properly due to the condition of the radio wave. (→P.131,142)



The rear door cannot be opened

- Is the child-protector lock set?

The rear door cannot be opened from inside the vehicle when the lock is set. Open the rear door from outside and then unlock the child-protector lock. (→P.137)

If you think something is wrong



The hybrid system does not start (vehicles without a smart entry & start system)

- Is the shift lever in P? (→P.173)
- Is the steering wheel unlocked? (→P.173)
- Is the 12-volt battery discharged? (→P.409)



The hybrid system does not start (vehicles with a smart entry & start system)

- Did you press the power switch

while firmly depressing the brake pedal? (→P.175)

- Is the shift lever in P? (→P.175)
- Is the electronic key anywhere detectable inside the vehicle? (→P.141)
- Is the steering wheel unlocked? (→P.176)
- Is the electronic key battery weak or depleted?

In this case, the hybrid system can be started in a temporary way. (→P.408)

- Is the 12-volt battery discharged? (→P.409)



The shift lever cannot be shifted from P even if you depress the brake pedal

- Is the power switch in ON?

If you cannot release the shift lever by depressing the brake pedal with the power switch in ON. (→P.182)



The steering wheel cannot be turned after the hybrid system is stopped

- Vehicles without a smart entry & start system: It is locked to prevent theft of the vehicle if the key is pulled from the power switch. (→P.173)
- Vehicles with a smart entry & start system: It is locked automatically to prevent theft of the vehicle. (→P.176)



The windows do not open or close by operating the power window switches

- Is the window lock switch pressed?

The power window except for the one at the driver's seat cannot be operated if the window lock switch is pressed. (→P.158)



The power switch is turned off automatically (vehicles with a smart entry & start system)

- The auto power off function will be operated if the vehicle is left in ACC or ON (the hybrid system is not operating) for a period of time. (→P.178)



A warning buzzer sounds during driving

- The seat belt reminder light is flashing

Are the driver and the passenger wearing the seat belts? (→P.377)

- The parking brake indicator is on
- Is the parking brake released? (→P.184)

Depending on the situation, other types of warning buzzer may also sound. (→P.374, 383)



An alarm is activated and the horn sounds (vehicles with an alarm)

- Did anyone inside the vehicle

open a door or anything move inside the vehicle during setting the alarm?

The sensor detects it and the alarm sounds. (→P.86)

Do one of the following to deactivate or stop the alarms:

- Unlock the doors using the entry function (if equipped) or wireless remote control.
- Starting the hybrid system. (The alarm will be deactivated or stopped after a few seconds.)



A warning buzzer sounds when leaving the vehicle (vehicles with a smart entry & start system)

- Is the electronic key left inside the vehicle?

Check the message on the multi-information display. (→P.383)



A warning light turns on or a warning message is displayed

- When a warning light turns on or a warning message is displayed, refer to P.374, 383.

When a problem has occurred



If you have a flat tire

- Vehicles with an emergency tire

puncture repair kit: Stop the vehicle in a safe place and repair the flat tire temporarily with the emergency tire puncture repair kit. (→P.386)

- Vehicles with spare tire: Stop the vehicle in a safe place and replace the flat tire with the spare tire. (→P.397)



The vehicle becomes stuck

- Try the procedure for when the vehicle becomes stuck in mud, dirt, or snow. (→P.417)

Alphabetical Index

A

A/C

- Air conditioning filter..... 346
- Automatic air conditioning system
..... 288

ABS (Anti-lock Brake System) 277

- Warning light 376

ACA (Active Cornering Assist).... 277

Acoustic vehicle alerting system.. 78

Active Cornering Assist (ACA).... 277

AHB (Automatic High Beam) 193

Air conditioning filter 346

Air conditioning system

- Air conditioning filter..... 346
- Automatic air conditioning system
..... 288

Airbag manual on-off system 45

Airbags 36

- Airbag manual on-off system 45
- Airbag operating conditions 38
- Airbag precautions for your child . 41
- Correct driving posture..... 31
- Curtain shield airbag operating conditions 38
- Curtain shield airbag precautions 41
- General airbag precautions..... 41

- Locations of airbags 36

- Modification and disposal of airbags
..... 43

- Side airbag operating conditions.. 38

- Side airbag precautions 41

- Side and curtain shield airbags operating conditions 38

- Side and curtain shield airbags precautions..... 41

- SRS airbags 36

- SRS warning light..... 376

Alarm..... 86

- Alarm..... 86

- Warning buzzer 374

Antennas (smart entry & start system) 140

Anti-lock Brake System (ABS)..... 277

- Warning light 376

Approach warning 237

Assist grips 308

Audio system-linked display 107, 113

Automatic air conditioning system 288

Automatic High Beam 193

Automatic light control system ... 191

Auxiliary box 301

Average fuel economy 105, 110

Average vehicle speed 107, 113

B	C
Back door 137	Care312, 315
Back-up light	Aluminum wheels312
Replacing light bulbs 358	Exterior312
Battery (12-volt battery) 330	Interior315
Battery checking 330	Seat belts315
If the 12-volt battery is discharged	Cargo and luggage 166
..... 409	Chains285
Preparing and checking before winter	Child restraint system47
..... 284	Points to remember47
Warning light 375	Riding with children46
Battery (traction battery) 79	Child safety46
Blind Spot Monitor (BSM) 248	12-volt battery precautions.331, 413
Enabling/disabling the Blind Spot	Airbag precautions41
Monitor 250	Child restraint system.....47
Bottle holders 298	Heated steering wheel and seat
Brake	heater precautions293
Brake hold 187	How your child should wear the seat
Emergency brake signal 277	belt34
Fluid 426	Installing child restraints47
Parking brake 184	Power window lock switch..... 158
Regenerative braking 77	Power window precautions 157
Warning light 374	Rear door child-protectors..... 137
Brake assist277	Removed electronic key battery pre-
Break-in tips 161	cautions.....354
Brightness control	Seat belt precautions46
Instrument panel light control98, 103	Child-protectors 137
BSM (Blind Spot Monitor) 248	
Enabling/disabling the Blind Spot	
Monitor 250	

Cleaning 312, 315
 Aluminum wheels 312
 Exterior 312
 Interior 315
 Radar sensor 205
 Seat belts 315
Clock 94, 97, 99, 102
Coat hooks 308
Condenser 329
Console box 299
Consumption screen 120
Cooling system 327
 Engine overheating 414
 Hybrid system overheating 414
Cruise control
 Dynamic radar cruise control with
 full-speed range 230
Cup holders 298
Current fuel consumption.... 105, 110
Curtain shield airbags 36
Customizable features 431

D

Daytime running light system 190
Deck board 299
Defogger
 Outside rear view mirrors 290
 Rear window 290
 Windshield 290

Dimensions 420
Display
 Consumption screen 120
 Dynamic radar cruise control with
 full-speed range 230
 Energy monitor 120
 Head-up display 116
 LTA (Lane Tracing Assist) 225
 Multi-information display 103, 109
 Speed limiter 242
 Toyota parking assist-sensor 253
 Warning message 383
Display change button 96, 101
**Distance until next engine oil change
 97, 101**
Do-it-yourself maintenance 318
Door
 Double locking system 85
Door lock
 Back door 137
 Side doors 133
 Smart entry & start system 140
 Wireless remote control 130
Doors
 Back door 137
 Door glasses 156
 Door lock 133, 137
 Open door warning buzzer. 134, 136
 Outside rear view mirrors 153
 Rear door child-protectors 137
 Side doors 133

- Double locking system** 85
 - Drive distance** 107, 113
 - Drive information** 107, 113
 - Drive-start control** 165
 - Driving** 160
 - Break-in tips 161
 - Correct driving posture 31
 - Driving mode select switch 275
 - Hybrid vehicle driving tips 282
 - Procedures 160
 - Winter drive tips 284
 - Driving information display** . 104, 110
 - Driving range** 105, 110
 - Driving support system information display** 107, 112
 - Dynamic radar cruise control with full-speed range** 230
 - Road Sign Assist (RSA) 238
 - Warning message 240
- E**
- eCall** 66
 - “SOS” button 66
 - ECB (Electronically Controlled Brake System)** 277
 - Warning light 374
 - ECO Accelerator Guidance**.. 105, 111
 - Eco drive mode** 275
 - Eco score** 105, 111
 - Elapsed time** 107, 113
 - Electric motor (traction motor)**..... 76
 - Electric Power Steering (EPS)**..... 277
 - Warning light 377
 - Electronic key** 128
 - Battery-saving function 141
 - If the electronic key does not operate properly 407
 - Replacing the battery 351
 - Electronically Controlled Brake System (ECB)** 277
 - Warning light 374
 - Emergency brake signal** 277
 - Emergency flashers** 366
 - Emergency tire puncture** 386
 - Emergency, in case of**
 - If a warning buzzer sounds 374
 - If a warning light turns on 374
 - If a warning message is displayed 383
 - If the 12-volt battery is discharged 409
 - If the electronic key does not operate properly 407
 - If the hybrid system will not start 405
 - If the vehicle is trapped in rising water 367
 - If you have a flat tire 386, 397
 - If you lose your keys 407
 - If you think something is wrong .. 372
 - If your vehicle becomes stuck 417
 - If your vehicle has to be stopped in an emergency 366
 - If your vehicle needs to be towed 369
 - If your vehicle overheats 414
 - Energy monitor** 120

Engine421
 ACC 174, 177
 Compartment 325
 Engine switch..... 173, 175
 Hood 322
 How to start the hybrid system. 173,
 175
 Identification number..... 421
 If the hybrid system will not start 405
 If your vehicle has to be stopped in
 an emergency 366
 Ignition switch (power switch) .. 173,
 175
 Overheating 414
 Power switch..... 173, 175
 Tachometer 119
Engine coolant..... 327
 Capacity 425
 Checking 327
 Preparing and checking before win-
 ter 284
Engine coolant temperature gauge
 **94, 99**
Engine oil 325
 Capacity 423
 Checking 325
 Preparing and checking before win-
 ter 284
 Warning light 375
Engine oil maintenance data 327
Engine switch (power switch) ... 173,
175
 If your vehicle has to be stopped in
 an emergency 366

EPS (Electric Power Steering)277
 Warning light377
EV drive mode..... 179
EV indicator.....77

F

Flat tire
 Tire pressure warning system334
 Vehicles with a spare tire397
 Vehicles without a spare tire386
Floor mats30
Fluid
 Brake426
 Hybrid transmission.....426
 Washer329
Fog lights
 Replacing light bulbs 358, 360
 Switch..... 196
 Wattage428
Front fog lights
 Replacing light bulbs 358, 360
 Switch..... 196
 Wattage428
Front position lights
 Replacing light bulbs 358, 359
 Wattage428
Front seat center airbags.....36
Front seats 145
 Adjustment 145
 Cleaning315
 Correct driving posture.....31
 Head restraints..... 147
 Seat heaters.....293

Front turn signal lights **184**
 Replacing light bulbs 358, 360
 Turn signal lever 184
 Wattage 428
Fuel **202**
 Capacity 422
 Fuel gauge 94, 99
 Information 430
 Refueling 202
 Type 422
 Warning light 377
Fuel consumption
 Average fuel economy 105, 110
 Current fuel consumption... 105, 110
Fuel economy **105, 110**
Fuel filler door **202**
 Refueling 202
Fuel gauge **94, 99**
Fuses **354**

G

Gauges **94, 99**
Glove box **298**
GPF (Gasoline Particulate Filter) system **276**
Grocery bag hooks **299**

H

Head restraints **147**
Head-up display **116**
 Driving information display area 116
 Driving support system display area 118
 Hybrid System Indicator 119
 Navigation system-linked display area 118
 Pop-up display 118
 Settings 117
Headlamp temporary lighting function **192**
Headlights
 Automatic High Beam system 193
 Headlamp temporary lighting function 192
 Light switch 190
 Replacing light bulbs 358
 Wattage 428
Heated steering wheel **293**
Heaters
 Automatic air conditioning system 288
 Heated steering wheel 293
 Outside rear view mirrors 290
 Seat heaters 293

High mounted stoplight
 Replacing light bulbs 358

High-voltage components 79

Hill-start assist control..... 277

Hood 322
 Open 322

Hooks
 Coat hooks 308
 Grocery bag hooks 299
 Retaining hooks (floor mat) 30

Horn 151

Hybrid battery (traction battery)
 Location 79
 Specification 422
 Warning message 83

Hybrid battery (traction battery) air intake vent 348

Hybrid battery (traction battery) air vents 82

Hybrid system..... 76
 Acoustic vehicle alerting system .. 78
 Emergency shut off system 82
 Energy monitor/consumption screen 120
 EV drive mode 179
 High voltage components 79
 Hybrid System Indicator 94, 99
 Hybrid system precautions 79
 If the hybrid system will not start 405
 Overheating 414
 Power (ignition) switch 173, 175
 Regenerative braking 77
 Starting the hybrid system . 173, 175

Hybrid System Indicator .. 94, 99, 119

Hybrid transmission 181

Hybrid vehicle driving tips..... 282

I

Identification
 Engine 421
 Vehicle 420

Ignition switch (power switch) .. 173, 175
 Auto power off function 178
 Changing the power switch modes 174, 177
 If your vehicle has to be stopped in an emergency 366

Illuminated entry system..... 296

Immobilizer system 84

Indicators..... 92

Initialization
 Engine oil maintenance data 327
 Items to initialize 440
 Parking Support Brake 269
 Power windows 156
 Tire pressure warning system 337

Inside rear view mirror 152

Interior lights..... 295
 Wattage 428

J

Jack
 Positioning a floor jack 323
 Vehicle-equipped jack 398
Jack handle **398**
Jam protection function
 Power windows 156

K

Keyless entry
 Smart entry & start system 140
 Wireless remote control 130
Keys **128**
 Battery-saving function 141
 Electronic key 128
 If the electronic key does not operate properly 407
 If you lose your keys 407
 Key number plate 128
 Keyless entry 133, 139, 140
 Mechanical key 128
 Power switch 173, 175
 Replacing the battery 351
 Warning buzzer 141
 Wireless remote control 130

L

Lane Tracing Assist (LTA) **220**
 Operation 220
 Warning lights 378
 Warning messages 229
Language (multi-information display) **108, 113**

Lever

Auxiliary catch lever 322
 Hood lock release lever 322
 Shift lever 181
 Turn signal lever 184
 Wiper lever 197

License plate light

 Replacing light bulbs 363

License plate lights

 Light switch 190
 Wattage 428

Light bulbs

 Replacing 357

Lights

 Automatic High Beam system 193
 Fog light switch 196
 Headlamp temporary lighting function 192
 Headlight switch 190
 Interior lights 295
 Interior lights list 295
 Luggage compartment light 140
 Personal lights 296
 Replacing light bulbs 358
 Turn signal lever 184
 Vanity lights 307
 Wattage 428

Lock steering column **173, 176**

LTA (Lane Tracing Assist) **220**

 Operation 220
 Warning lights 378
 Warning messages 229

Luggage compartment features .. **299**

 Auxiliary box 301
 Deck board 299
 Tonneau cover 302

Luggage compartment light

 Wattage 428

M

- Maintenance**
 - Do-it-yourself maintenance 320
 - Maintenance data 420
 - Maintenance requirements 318
- Malfunction indicator lamp..... 375**
- Manual headlight leveling dial.... 192**
- Menu icons..... 103, 109**
- Meter**
 - Clock 94, 99
 - Indicators 92
 - Instrument panel light control 98, 103
 - Meter control switches 104, 110
 - Meters 94, 99
 - Multi-information display 103, 109
 - Settings 108, 113
 - Warning lights 91, 374
 - Warning message 383
- Mirrors**
 - Inside rear view mirror 152
 - Outside rear view mirror defoggers
..... 290
 - Outside rear view mirrors 153
 - Vanity mirrors 307
- Multi-information display..... 103, 109**
 - Audio system-linked display 107, 113
 - Clock 97, 102, 102
 - Cruise control 242
 - Driving information display . 104, 110
 - Driving support system information
display 107, 112
 - Dynamic radar cruise control with
full-speed range 230
 - ECO Accelerator Guidance 105, 111
 - Eco score 105, 111

- Energy monitor 120
- Fuel economy..... 105, 110
- LTA (Lane Tracing Assist)..... 225
- Menu icons 103, 109
- Meter control switches 104, 110
- Navigation system-linked display
..... 107, 112
- Settings 108, 113
- Tire pressure 334
- Toyota parking assist-sensor..... 253
- Vehicle information display. 107, 113
- Warning message 383

N

- Navigation system-linked display
..... 107, 112, 116**

O

- Odometer..... 96, 101**
- Odometer and trip meter display**
 - Display change button..... 96, 101
 - Display items..... 97, 101
- Oil**
 - Engine oil 423
- Opener**
 - Back door 139
 - Fuel filler door 202
 - Hood..... 322
- Outside rear view mirrors**
 - Adjustment 153
 - BSM (Blind Spot Monitor)..... 248
 - Folding 154
 - Outside rear view mirror defoggers
..... 290
 - RCTA (Rear Crossing Traffic Alert)
..... 260

Outside temperature 94, 99, 119
Overheating 414

P

Panoramic roof shade..... 309
Parking assist sensors (Toyota parking assist-sensor) 253
Parking brake..... 184
 Operation 184
 Parking brake engaged warning buzzer 186
 Warning light 380
 Warning message 186
Parking Support Brake (PKSB) ... 265
 Enabling/disabling the Parking Support Brake 266
 Parking Support Brake function (rear-crossing vehicles) 273
 Parking Support Brake function (static objects) 270
 Warning lights 379
 Warning message 269
PCS (Pre-Collision System)..... 209
 Enabling/disabling the pre-collision system 212
 Function 209
 Warning light 380
Personal lights..... 295
 Wattage 428

PKSB (Parking Support Brake) ... 265
 Enabling/disabling the Parking Support Brake 266
 Parking Support Brake function (rear-crossing vehicles)..... 273
 Parking Support Brake function (static objects)..... 270
 Warning lights..... 379
 Warning message 269
Power control unit 79
Power control unit coolant 327
 Capacity 425
 Checking 327
 Preparing and checking before winter 284
Power mode 275
Power outlet 303
Power steering (Electric power steering system) 277
 Warning light 377
Power switch 173, 175
 Auto power off function 178
 Changing the power switch modes 174, 177
Power switch (engine switch)
 If your vehicle has to be stopped in an emergency 366

Power windows
 Door lock linked window operation 157
 Jam protection function 156
 Operation 156
 Window lock switch 158
Pre-Collision System (PCS).....209
 Enabling/disabling the pre-collision system 212
 Function 209
 Warning light 380

R

Radar cruise control (dynamic radar cruise control with full-speed range) 230
Radiator 329
RCTA (Rear Crossing Traffic Alert) 260
 Enabling/disabling the Rear Crossing Traffic Alert 260
 Warning lights 379
Rear Crossing Traffic Alert (RCTA) 260
 Enabling/disabling the Rear Crossing Traffic Alert 260
 Warning lights 379

Rear fog lights
 Switch..... 196
Rear seats..... 146
 Head restraints 147
Rear turn signal lights 184
 Replacing light bulbs 358, 361
 Turn signal lever 184
 Wattage 428
Rear view mirror
 Inside rear view mirror 152
 Outside rear view mirrors 153
Rear window defogger 290
Rear window wiper 200
Refueling 202
 Capacity 422
 Fuel types 422
 Opening the fuel tank cap 202
Regenerative braking 77
 Warning lights 374
Replacing
 Electronic key battery 351
 Fuses 354
 Light bulbs 357
 Tires 397
 Wireless remote control battery . 351
Road accident cautions 80
Road Sign Assist 244
RSA (Road Sign Assist) 244

S

- Seat belt reminder light**..... 377
- Seat belts** 33
 - Child restraint system installation 47
 - Cleaning and maintaining the seat belt 315
 - Emergency Locking Retractor..... 35
 - How to wear your seat belt 34
 - How your child should wear the seat belt 34
 - Pregnant women, proper seat belt use 33
 - Reminder light and buzzer 377
 - Seat belt pretensioners 35
 - SRS warning light 376
- Seat heaters** 293
- Seats** 145, 146
 - Adjustment 145
 - Adjustment precautions 145
 - Child seats/child restraint system installation 47
 - Cleaning 315
 - Head restraints 147
 - Properly sitting in the seat 31
 - Seat heaters 293
- Secondary Collision Brake** 277
- Sensor**
 - Automatic headlight system 191
 - Automatic High Beam system 193
 - BSM (Blind Spot Monitor) 248
 - Inside rear view mirror 153
 - LTA (Lane Tracing Assist) 220
 - Parking Support Brake function (static objects) 253
 - Radar sensor 204, 249
 - Rain-sensing windshield wipers. 199
 - RCTA (Rear Crossing Traffic Alert) 260
 - Toyota parking assist-sensor 253
- Service plug** 79
- Shift lever**
 - Hybrid transmission 181
 - If the shift lever cannot be shifted from P 182
- Shift lock system** 182
- Side airbags** 36
- Side mirrors**
 - Adjustment 153
 - BSM (Blind Spot Monitor) 248
 - Folding 154
 - RCTA (Rear Crossing Traffic Alert) 260
- Side turn signal lights** 184
 - Replacing light bulbs 358
 - Turn signal lever 184
- Side windows** 156
- Smart entry & start system** 140
 - Antenna location 140
 - Entry functions 133, 139
 - Starting the hybrid system 175
- Snow tires** 284
- Spare tire** 397
 - Inflation pressure 427
 - Storage location 398
- Spark plug** 425
- Specifications** 420
- Speed limiter** 242
 - Warning message 243
- Speedometer** 94, 99
- Steering lock**
 - Column lock release 173, 176
 - Steering lock system warning message 176
- Steering wheel**
 - Adjustment 151
 - Heated steering wheel 293
 - Meter control switches 104, 110

Stop lights
 Emergency brake signal 277
 Replacing light bulbs 358

Storage features 297

Stuck
 If the vehicle becomes stuck 417

Sun visors 307

Switches
 Airbag manual on-off switch 45
 Automatic High Beam system 193
 Brake Hold switch 187
 Display change button 96, 101
 Door lock switches 136
 Driving mode select switch 275
 Dynamic radar cruise control with
 full-speed range switch 230
 Emergency flashers switch 366
 EV drive mode switch 179
 Heated steering wheel switch 293
 Ignition switch 173, 175
 Light switches 190
 LTA (Lane Tracing Assist) switch 225
 Meter control switches 104, 110
 Outside rear view mirror switches
 153
 Parking brake switch 184
 Power door lock switch 136
 Power switch 173, 175
 Power window switches 156
 Rear window and outside rear view
 mirror defoggers switch 288
 Seat heater switches 293
 "SOS" button 66
 Speed limiter switch 242
 Vehicle-to-vehicle distance switch
 230
 VSC OFF switch 278
 Window lock switch 158
 Windshield wiper and washer switch
 197

T

Tail lights
 Light switch 190
 Replacing light bulbs 358

Theft deterrent system
 Alarm 86
 Double locking system 85
 Immobilizer system 84

Tire inflation pressure 342
 Maintenance data 427
 Warning buzzers 378
 Warning light 378

Tire pressure warning system 334
 Function 334
 Initializing 337
 Installing tire pressure warning
 valves and transmitters 336
 Registering ID codes 339
 Selecting wheel set 341
 Warning buzzers 378
 Warning light 378

Tires 332
 Chains 285
 Checking 332
 Emergency tire puncture repair kit
 386
 If you have a flat tire 386, 397
 Inflation pressure 342
 Replacing 397
 Rotating tires 334
 Size 427
 Snow tires 284
 Spare tire 397
 Tire pressure warning system 334
 Warning buzzers 378
 Warning light 378

Tonneau cover 302

Tools 388, 398

Top tether anchorages 61

Towing

- Emergency towing 369
- Towing capacity..... 420
- Towing eyelet 371
- Trailer towing 167

Toyota parking assist-sensor 253

- Enabling/disabling the Toyota parking assist-sensor..... 254
- Function 253
- Warning lights 379
- Warning message 255

Toyota Safety Sense..... 204

- Automatic High Beam 193
- Dynamic radar cruise control with full-speed range 230
- LTA (Lane Tracing Assist) 220
- PCS (Pre-Collision System)..... 209
- RSA (Road Sign Assist) 244

Traction battery (hybrid battery) ... 79

- Hybrid battery (traction battery) air vents 82
- Location 79
- Specification..... 422
- Warning message 83

Traction Control (TRC) 277**Traction motor (electric motor) 76****Trailer towing 167****Transmission**

- Driving mode select switch 275
- Hybrid transmission 181
- If the shift lever cannot be shifted from P 182

TRC (Traction Control) 277**Trip meters 96, 101****Turn signal lights 184**

- Replacing light bulbs 358
- Turn signal lever 184
- Wattage 428

V**Vanity lights 307**

- Wattage 428

Vanity mirrors..... 307**Vehicle data recording 7****Vehicle identification number 420****Vehicle information display . 107, 113****Vehicle Stability Control (VSC).... 277****Vehicle Stability Control+ (VSC+) 277****VSC (Vehicle Stability Control).... 277****VSC+ (Vehicle Stability Control+) 277****W****Warning buzzers**

- Approach warning 237
- Brake hold 381
- Brake Override System 376
- Brake system 374
- Drive-Start Control 376
- Electric power steering 377
- Engine 375
- High coolant temperature 374
- Hybrid system 375
- Hybrid system overheat 375
- Key reminder 174
- Low engine oil pressure 375
- LTA (Lane Tracing Assist) ... 220, 378
- Open door 134, 136
- PCS (Pre-Collision System) 380
- PKSB (Parking Support Brake) .. 379
- RCTA (Rear Crossing Traffic Alert) 261, 379
- Seat belt 377
- SRS airbag 376
- Tire pressure 378
- Toyota parking assist-sensor.... 258, 379

Warning label 79

Warning lights..... 91, 374

 ABS..... 376

 Brake hold operated indicator 381

 Brake Override System..... 376

 Brake system 374

 Charging system 375

 Drive-Start Control 376

 Electric power steering..... 377

 High coolant temperature..... 374

 Hybrid system overheat 375

 Low engine oil pressure 375

 Low fuel level 377

 LTA indicator 378

 Malfunction indicator lamp 375

 Parking brake indicator 380

 PKSB OFF indicator..... 379

 Pre-collision system 380

 RCTA OFF indicator..... 379

 Seat belt reminder light..... 377

 Slip indicator 380

 SRS airbag..... 376

 Tire pressure 378

 Toyota parking assist-sensor OFF indicator 379

Warning messages..... 383

Washer..... 197

 Checking 329

 Preparing and checking before winter 284

 Switch 197

Washing and waxing 312

Weight..... 420

Wheels 344

 Replacing 344

 Size 427

Window lock switch 158

Windows

 Power windows 156

 Rear window defogger 290

 Washer 197

Windshield wipers 197

Winter driving tips 284

Wireless charger..... 303

Wireless remote control..... 130

 Battery-Saving Function 141

 Locking/Unlocking 130

 Replacing the battery 351

For vehicles with 7-inch/8-inch display multimedia system, refer to “Navigation and multimedia system Owner’s manual” for information regarding the equipment listed below.

- Navigation system
- Audio/visual system
- Rear view monitor system

For vehicles with 9-inch display multimedia system, refer to “TOYOTA SMART CONNECT Owner’s manual” for information regarding the equipment listed below.

- Navigation system
- Audio/visual system
- Rear view monitor system

GAS STATION INFORMATION

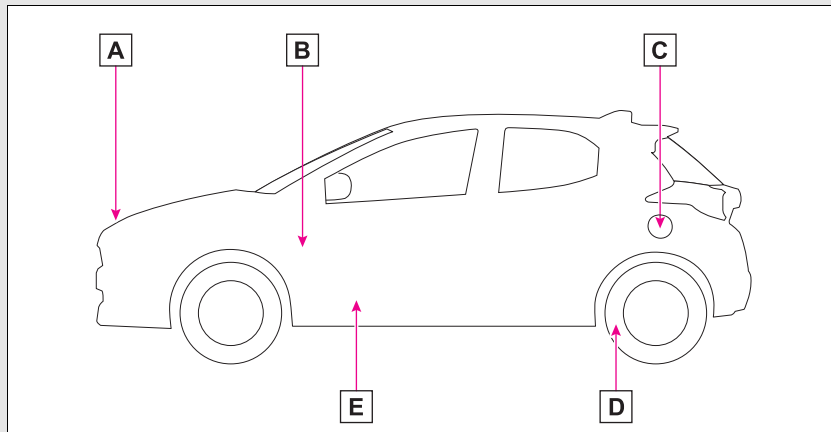

- A** Auxiliary catch lever (→P.322)
- B** Hood lock release lever (→P.322)
- C** Fuel filler door (→P.203)
- D** Tire inflation pressure (→P.427)
- E** Fuel filler door opener (→P.203)

Fuel tank capacity (Reference)	P.422
Fuel type	P.422 P.430
Cold tire inflation pressure	P.427
Engine oil capacity (Drain and refill — reference)	P.423
Engine oil type	P.423